

0CW10-M08900EN

PREFACE

1.This Parts Catalog carries all parts incorporated in YANMAR Model 3TNV76-GMA engine manufactured since January, 2006.

2.Each illustration corresponds to the parts list on the following page.

3.When ordering parts,clearly write down the engine model and serial number,as well as the name and number of each part in your order sheet. This will help insure reliable delivery of the parts you have ordered.

Contents

Fig. No. Fig. Name

ENGINE 3TNV76-GMA

1. CYLINDER BLOCK
2. GEAR HOUSING
3. FLYWHEEL HOUSING & OIL SUMP
4. CYLINDER HEAD & BONNET
5. CAMSHAFT & DRIVING GEAR
6. CRANKSHAFT & PISTON
7. LUB.OIL SYSTEM
8. COOLING WATER SYSTEM
9. FUEL INJECTION PUMP
10. GOVERNOR
11. FUEL INJECTION VALVE
12. FUEL LINE
13. STARTING MOTOR
14. GENERATOR
15. GASKET SET

Fig. No. Fig. Name

Fig.1. CYLINDER BLOCK

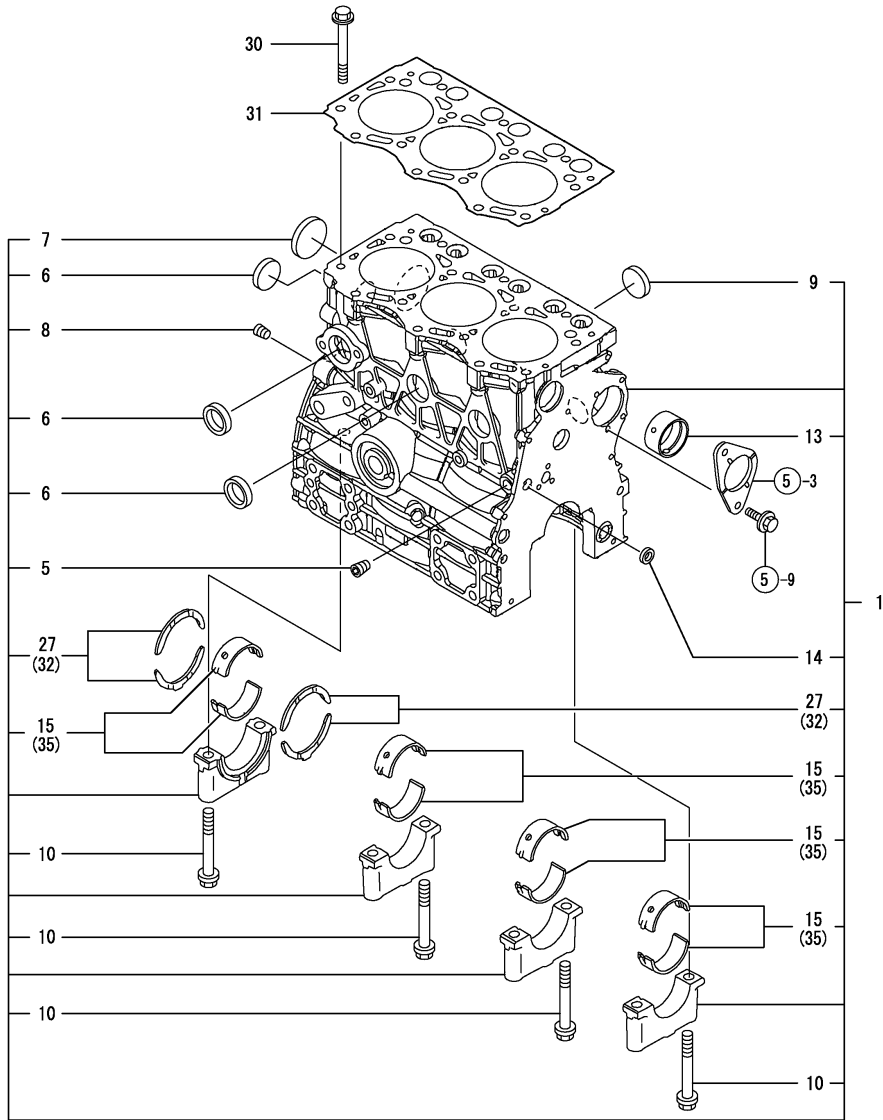

(A)=3TNV76-GMA

(B)=

(C)=

(D)=

(E)=

(F)=

No.	Lev.	Parts No.	Description	Q'ty						I	R
				(A)	(B)	(C)	(D)	(E)	(F)		
1	1	719717-01561	BLOCK ASSY, CYLINDER	1							
5	2	124060-01050	PLUG, PT1/8	1							
6	2	105311-01090	PLUG, 30	4							
7	2	119623-01250	PLUG, 45	1							
8	2	124160-01910	PLUG, PT1/4	1							
9	2	119285-01990	PLUG, 25	3							
10	2	119620-02020	BOLT, METAL CAP	8							
13	2	119717-02410	BUSH, CAMSHAFT	1							
14	2	27241-120000	PLUG, 12	1							
15	2	719717-02900	BEARING, MAIN	4							2
27	2	119810-02930	BEARING, THRUST	1							
30	1	119810-01200	BOLT, HEAD	14							
31	1	119717-01330	GASKET, HEAD	1							
32	1	119810-02940	BEARING, THRUST 0.25	2							1
35	1	719717-02910	BEARING, 0.25 US	4							3

Remarks
 (1) OVER-SIZE(O.S=0.25)PART.
 (2) REPAIR PART.
 (3) UNDER-SIZE(U.S=0.25)PART.

Fig.2. GEAR HOUSING

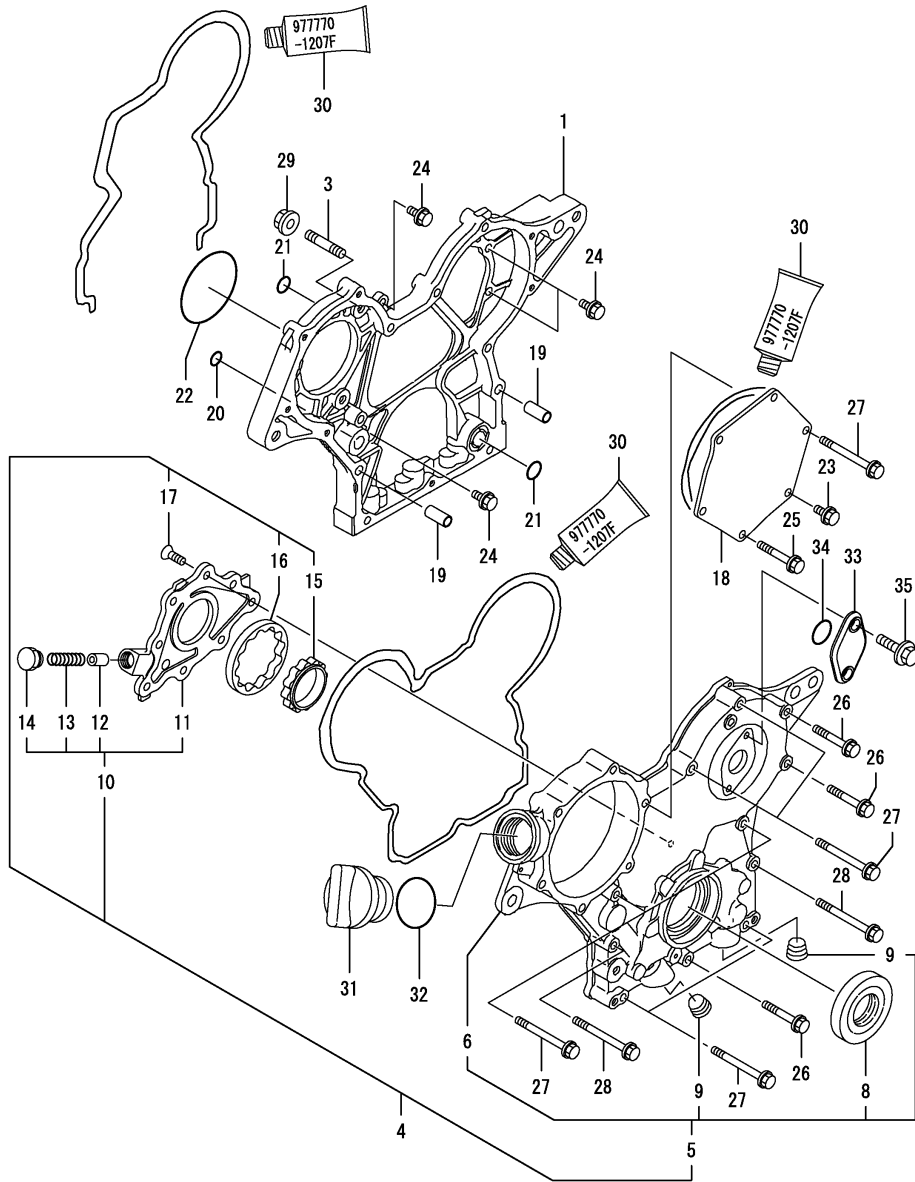

(A)=3TNV76-GMA

(B)=

(C)=

(D)=

(E)=

(F)=

No.	Lev.	Parts No.	Description	Q'ty						I	R
				(A)	(B)	(C)	(D)	(E)	(F)		
1	1	119717-01501	CASE, GEAR	1							
3	1	119717-01570	STUD	3							
4	1	119744-01590	COVER ASSY,GEAR CASE	1							
5	2	719744-01500	COVER ASSY,GEAR CASE	1							
6	3	119744-01521	COVER, GEAR CASE	1							
8	3	119620-01800	SEAL, OIL	1							
9	3	23876-030000	PLUG, R03	2							
10	2	119717-32100	COVER ASSY	1							
11	3	119717-32080	COVER	1							
12	3	129900-32130	VALVE, RELIEF	1							
13	3	129001-32320	SPRING	1							
14	3	129001-32330	PLUG	1							
15	2	119717-32110	ROTOR, INNER	1							
16	2	119717-32120	ROTOR, OUTER	1							
17	2	119802-32130	SCREW, M6X16	8							
18	1	119717-01750	COVER	1							
19	1	119660-01911	PIPE, KNOCK	4							
20	1	119624-32040	O-RING, P12.0	1							
21	1	119717-32050	O-RING, P17.0	3							
22	1	121850-51960	O-RING	1							
23	1	26106-060122	BOLT, M6X 12 PLATED	1							
24	1	26106-060162	BOLT, M6X 16 PLATED	4							
25	1	26106-060402	BOLT, M6X 40 PLATED	4							
26	1	26106-060402	BOLT, M6X 40 PLATED	3							
27	1	26106-060602	BOLT, M6X 60 PLATED	7							
28	1	26106-060652	BOLT, M6X 65 PLATED	2							
29	1	26306-080002	NUT, M8	3							
30	1	977770-1207F	GASKET.LIQUID	1							1
31	1	124160-01751	COVER, FILLER	1							
32	1	24311-000320	O-RING, 1AP32.0	1							
33	1	121023-01551	COVER	1							
34	1	24341-000240	O-RING, 1AS24.0	1							
35	1	26106-060162	BOLT, M6X 16 PLATED	2							

Remarks
(1) OPTIONAL PART.

Fig.3. FLYWHEEL HOUSING & OIL SUMP

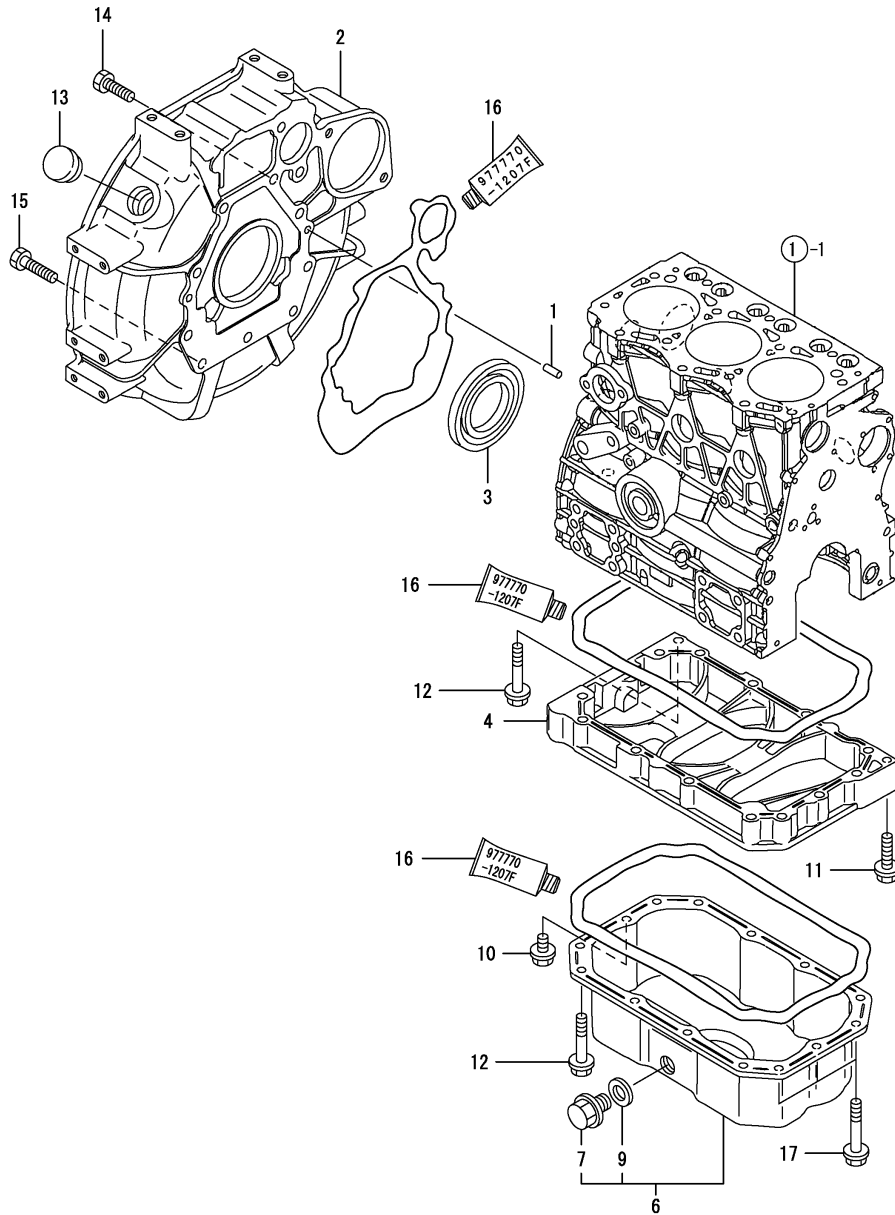

(A)=3TNV76-GMA

(B)=

(C)=

(D)=

(E)=

(F)=

No.	Lev.	Parts No.	Description	Q'ty						I	R
				(A)	(B)	(C)	(D)	(E)	(F)		
1	1	129100-01580	PIN, M8X16	2							
2	1	119717-01601	HOUSING, FLYWHEEL	1							
3	1	124085-02220	SEAL, OIL	1							
4	1	119717-01720	SPACER, OIL SUMP	1							
6	1	119717-01770	SUMP ASSY, OIL	1							
7	2	105425-01690	PLUG, 16	1							
9	2	22190-160002	WASHER, SEAL 16	1							
10	1	26106-080122	BOLT, M8X 12 PLATED	1							
11	1	26106-080302	BOLT, M8X 30 PLATED	1							
12	1	26106-080452	BOLT, M8X 45 PLATED	11							
13	1	119620-01750	CAP	1							
14	1	26206-100252	BOLT, M10X 25 PLATED	8							
15	1	121120-01620	BOLT, M10X28	3							
16	1	977770-1207F	GASKET.LIQUID	1							1
17	1	26106-080502	BOLT, M8X 50 PLATED	3							

Remarks
(1) OPTIONAL PART.

Fig.4. CYLINDER HEAD & BONNET

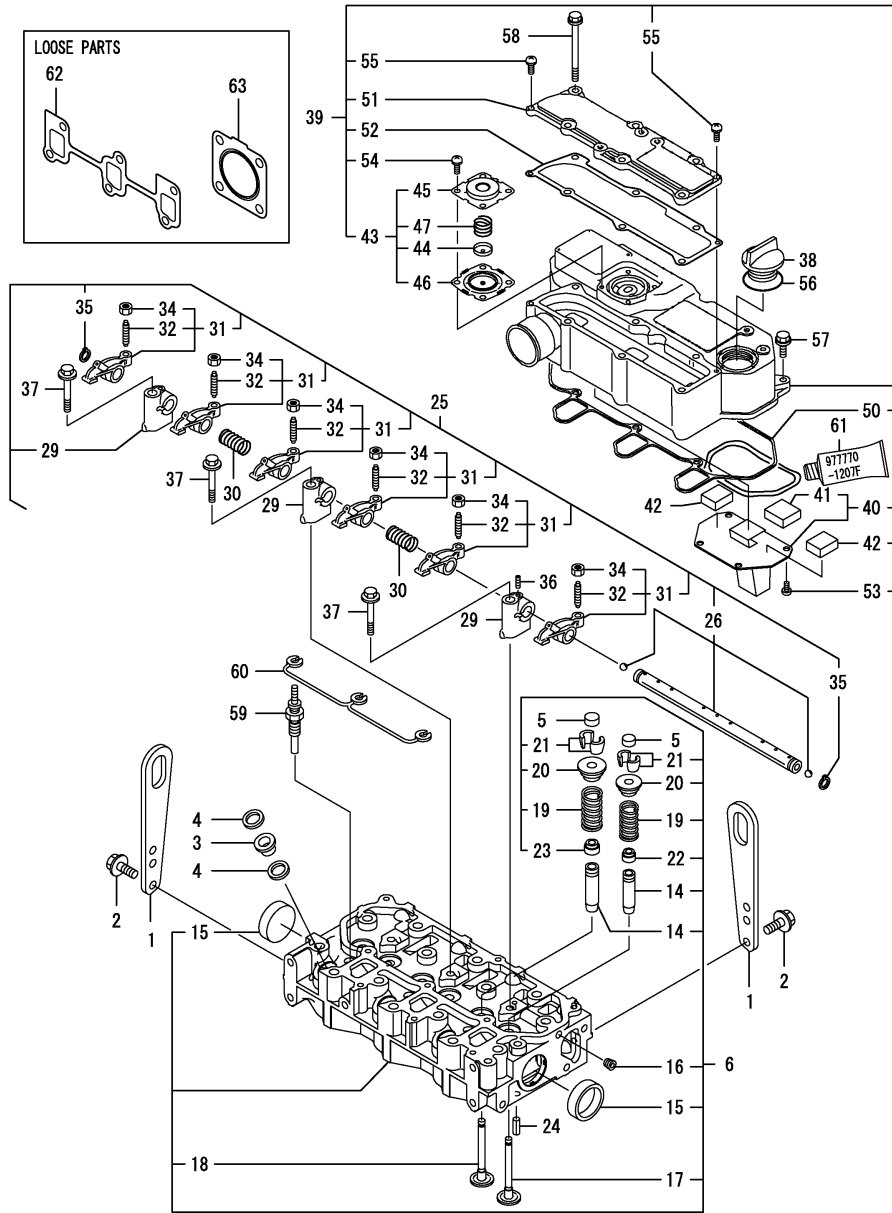

(A)=3TNV76-GMA

(B)=

(C)=

(D)=

(E)=

(F)=

No.	Lev.	Parts No.	Description	Q'ty						I	R
				(A)	(B)	(C)	(D)	(E)	(F)		
1	1	129900-07900	LIFTER	2							
2	1	26106-080162	BOLT, M8X 16 PLATED	4							
3	1	129901-11450	PROTECTOR, NOZZLE	3							
4	1	119600-11460	GASKET, NOZZLE	6							
5	1	105010-11490	CAP, VALVE	6							
6	1	119717-11740	HEAD ASSY, CYLINDER	1							
14	2	119717-11800	GUIDE, VALVE	6							1
15	2	119285-11990	PLUG, 35	2							
16	2	23876-005000	PLUG, R005	1							
17	2	119717-11100	VALVE, INTAKE	3							
18	2	119717-11110	VALVE, EXHAUST	3							
19	2	119717-11131	SPRING, VALVE	6							
20	2	129508-11180	RETAINER, SPRING	6							
21	2	119717-11190	COTTER	12							
22	2	119717-11340	SEAL, VALVE STEM	3							
23	2	119717-11350	SEAL, VALVE STEM	3							
24	1	22351-060012	PIN, SPRING 6.0X12	2							
25	1	119717-11200	SUPPORT ASSY, ARM	1							
26	2	119717-11240	SHAFT ASSY, ROCKER	1							
29	2	119717-11260	SUPPORT, ROCKER ARM	3							
30	2	119620-11280	SPRING	2							
31	2	119717-11650	ARM, ROCKER	6							
32	3	129150-11230	SCREW, VALVE ADJUST	6							
34	3	129150-11750	NUT, M8	6							
35	2	22242-000120	RING, 12	2							
36	2	26979-050162	SCREW, M5X16	1							
37	1	26106-080402	BOLT, M8X 40 PLATED	3							
38	1	124160-01751	COVER, FILLER	1							
39	1	119717-11381	BONNET ASSY, HEAD	1							
40	2	119717-03031	PLATE	1							
41	3	119717-03070	BAFFLE, BREATHER	1							
42	2	119717-03070	BAFFLE, BREATHER	2							
43	2	119802-03100	DIAPHRAGM ASSY	1							
44	3	119802-03110	PLATE	1							
45	3	119802-03121	COVER, DIAPHRAGM	1							
46	3	119802-03131	DIAPHRAGM	1							
47	3	119802-03141	SPRING, DIAPHRAGM	1							
50	2	119718-11310	GASKET, BONNET	1							
51	2	119717-11320	COVER, BONNET	1							
52	2	119717-11331	GASKET	1							
53	2	22857-500100	SCREW, 5X10	4							
54	2	22857-500100	SCREW, 5X10	4							
55	2	22857-500160	SCREW, 5X16	2							
56	1	24311-000320	O-RING, 1AP32.0	1							
57	1	26106-060202	BOLT, M6X 20 PLATED	3							
58	1	26106-060752	BOLT, M6X 75 PLATED	6							
59	1	119717-77800	PLUG, GLOW	3							
60	1	119717-77820	CONNECTOR, GLOW PLUG	1							
61	1	977770-1207F	GASKET, LIQUID	1							2
62	1	119717-13110	GASKET	1							
63	1	119515-13200	GASKET, SILENCER	1							

Remarks
 (1) REPAIR PART.
 (2) OPTIONAL PART.

Fig.5. CAMSHAFT & DRIVING GEAR

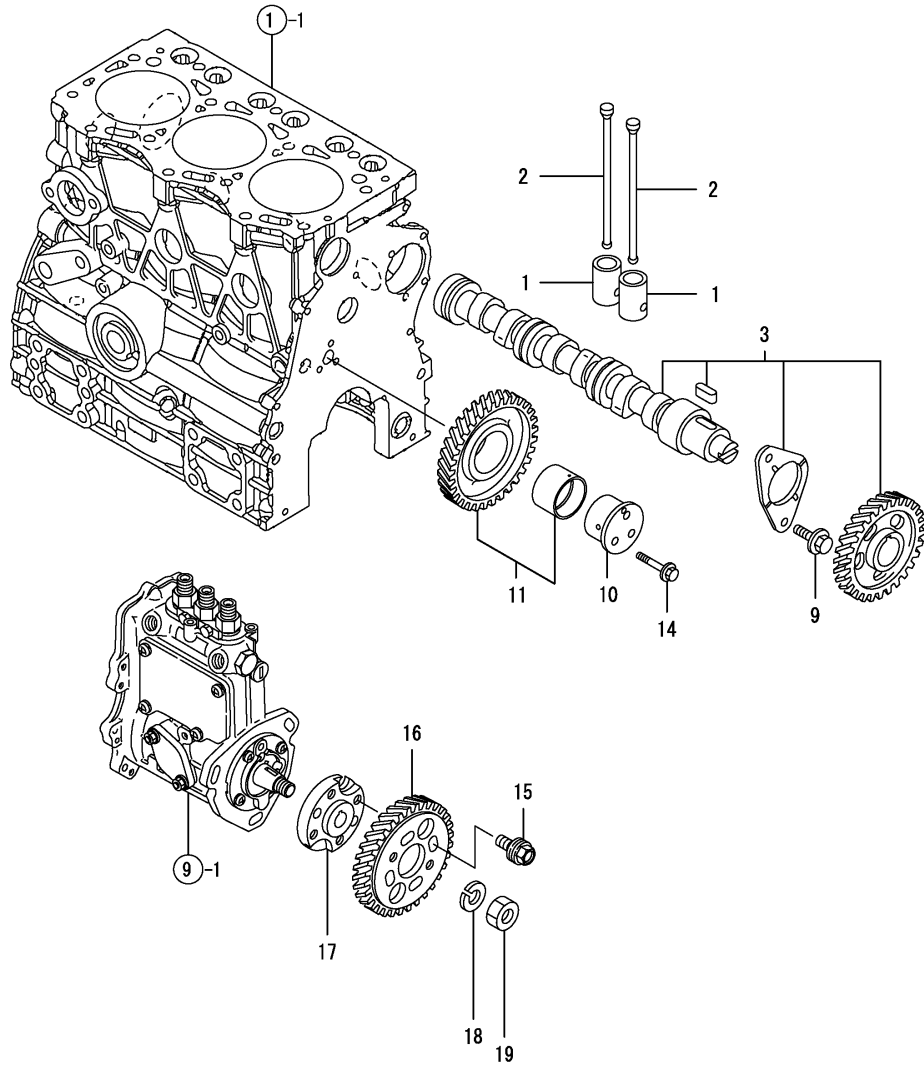

(A)=3TNV76-GMA

(B)=

(C)=

(D)=

(E)=

(F)=

No.	Lev.	Parts No.	Description	Q'ty						I	R
				(A)	(B)	(C)	(D)	(E)	(F)		
1	1	119620-14200	TAPPET	6							
2	1	119717-14400	ROD, PUSH	6							
3	1	119717-14580	CAMSHAFT ASSY	1							
9	1	26106-060122	BOLT, M6X 12 PLATED	2							
10	1	119717-25050	SHAFT, IDLE	1							
11	1	119717-25100	GEAR ASSY, IDLE	1							
14	1	26106-060352	BOLT, M6X 35 PLATED	3							
15	1	129150-25301	BOLT	4							
16	1	119717-25930	GEAR, PUMP	1							
17	1	119717-51150	FLANGE	1							
18	1	22217-120000	WASHER, SPRING 12	1							
19	1	26716-120002	NUT, M12	1							

Fig.6. CRANKSHAFT & PISTON

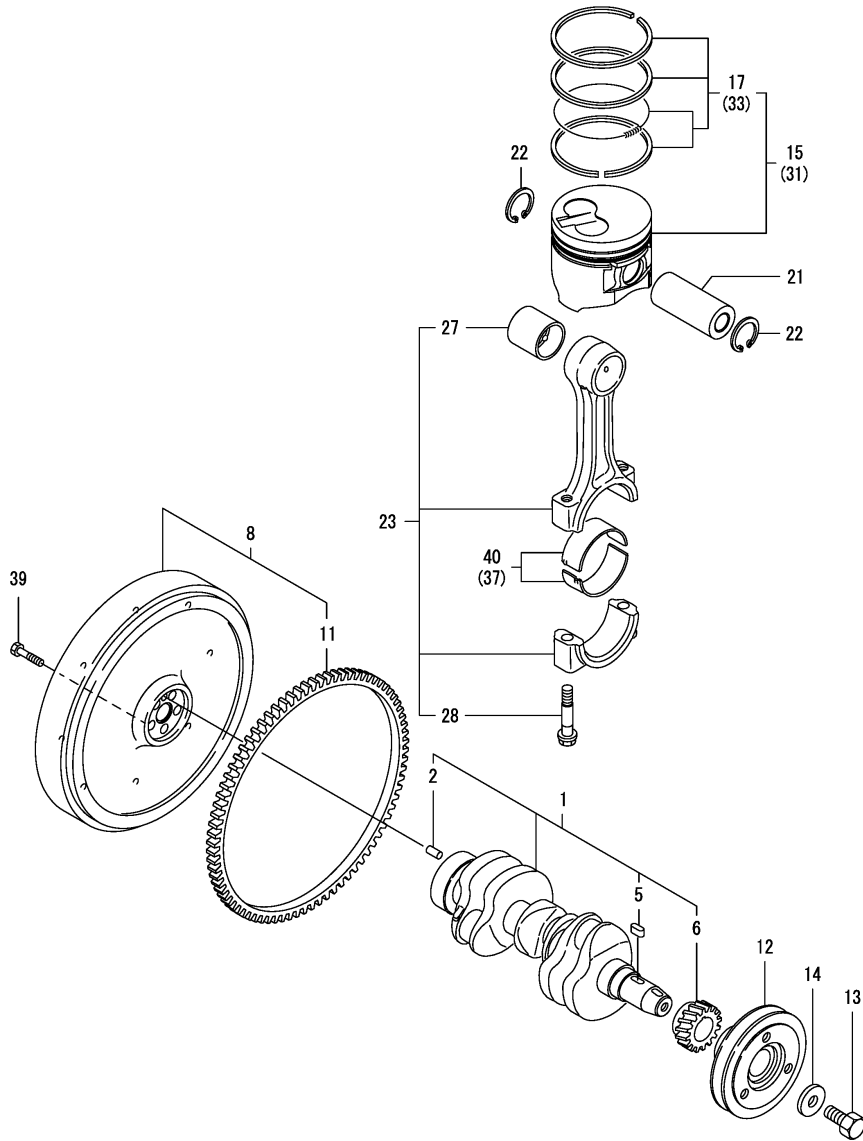

(A)=3TNV76-GMA

(B)=

(C)=

(D)=

(E)=

(F)=

No.	Lev.	Parts No.	Description	Q'ty						I	R
				(A)	(B)	(C)	(D)	(E)	(F)		
1	1	119717-21700	CRANKSHAFT ASSY	1							
2	2	129100-01580	PIN, M8X16	1							
5	2	22512-040120	KEY, 4X 12	1							
6	2	119717-21200	GEAR, CRANKSHAFT	1							
8	1	119636-21590	FLYWHEEL ASSY	1							
11	2	119865-21600	GEAR, RING	1							
12	1	119717-21650	V-PULLEY	1							
13	1	119621-21680	BOLT, FLANGE 12X1.25	1							
14	1	119620-21941	WASHER	1							
15	1	119717-22080	PISTON ASSY	3							
17	2	119717-22500	RING SET, PISTON	3							
21	1	119717-22300	PIN, PISTON	3							
22	1	22252-000220	RING, 22	6							
23	1	119717-23000	ROD ASSY, CONNECTING	3							
27	2	119717-23910	BEARING, PISTON PIN	3							2
28	2	119717-23200	BOLT, CONNECTING ROD	6							
31	1	119717-22900	PISTON ASSY, 0.25 OS	3							1
33	2	119717-22550	RING SET, 0.25 OS	3							1
37	1	119717-23610	METAL ASSY, 0.25	3							3
39	1	121111-21501	BOLT, FLYWHEEL	5							
40	1	119717-23600	BEARING, CRANK PIN	3							

Remarks

- (1) OVER-SIZE(O.S=0.25)PART.
- (2) REPAIR PART.
- (3) UNDER-SIZE(U.S=0.25)PART.

Fig.7. LUB.OIL SYSTEM

(A)=3TNV76-GMA

(B)=

(C)=

(D)=

(E)=

(F)=

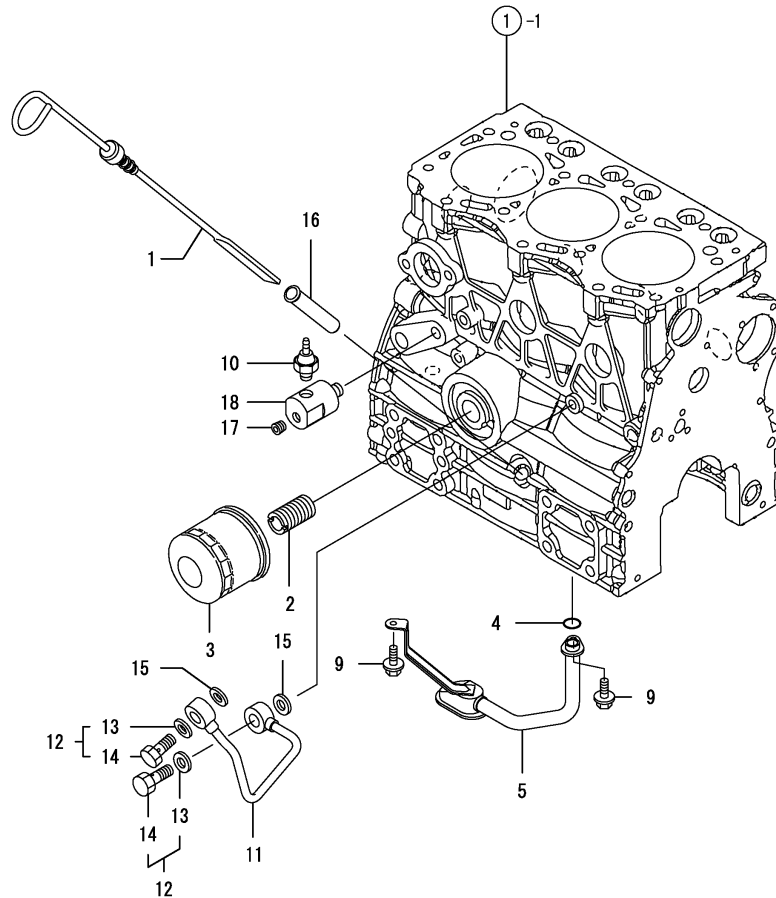

No.	Lev.	Parts No.	Description	Q'ty						I	R
				(A)	(B)	(C)	(D)	(E)	(F)		
1	1	119717-34801	DIPSTICK, OIL	1							
2	1	129100-35140	STUD	1							
3	1	119305-35151	FILTER ASSY, D68XL65	1							1
4	1	119717-32060	O-RING, P15.0	1							
5	1	119717-35080	PIPE ASSY, OIL INLET	1							
9	1	26106-060102	BOLT, M6X 10 PLATED	2							
10	1	114250-39450	SWITCH, 0.5KG	1							
11	1	119717-39210	PIPE, OIL	1							
12	1	129005-59830	BOLT ASSY, JOINT M8	2							
13	2	22190-080002	WASHER, SEAL 6	2							
14	2	23857-030000	BOLT, JOINT 3	2							
15	1	22190-080002	WASHER, SEAL 6	2							
16	1	121520-34810	GUIDE, DIPSTICK	1							
17	1	124060-01050	PLUG, PT1/8	1							
18	1	171375-39601	DAMPER, 1/8	1							

Remarks
(1) REPAIR PART.

Fig.8. COOLING WATER SYSTEM

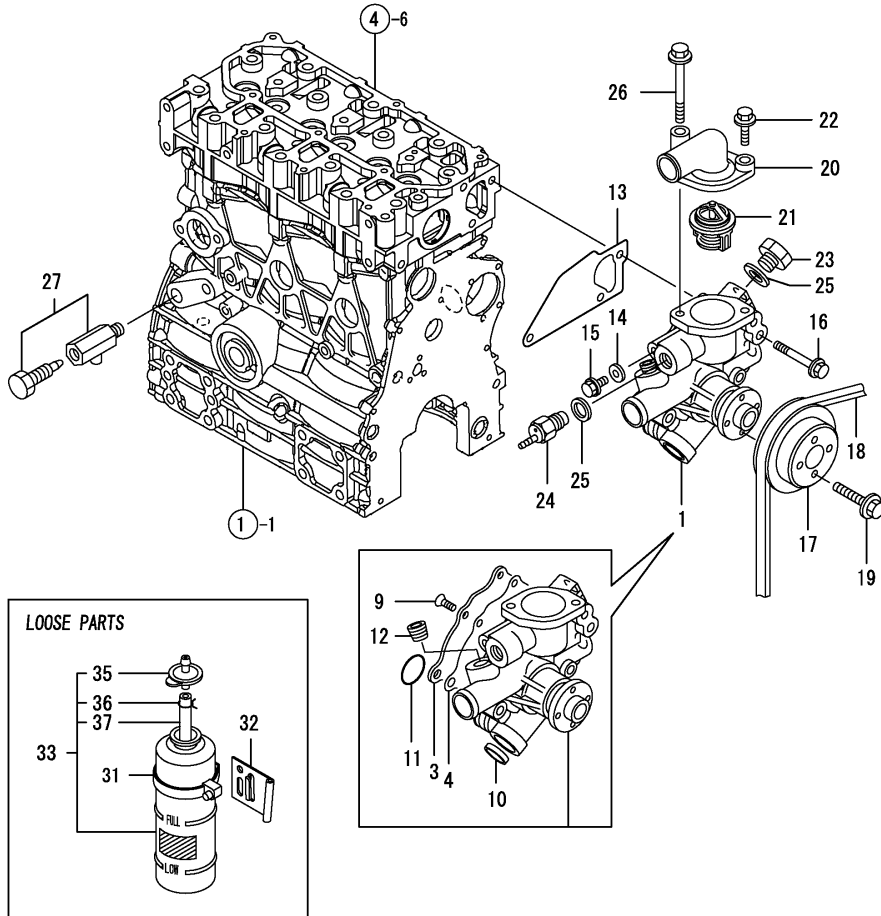

(A)=3TNV76-GMA

(B)=

(C)=

(D)=

(E)=

(F)=

No.	Lev.	Parts No.	Description	Q'ty						I	R
				(A)	(B)	(C)	(D)	(E)	(F)		
1	1	119717-42002	PUMP ASSY, WATER	1							
1-1	1	119E10-42000	PUMP ASSY, WATER	1							N
(A=E/ B4768)											
3	2	119717-42041	COVER	1							
4	2	119717-42031	GASKET	1							
9	2	26577-060122	SCREW, M6X12	4							
10	2	27241-250000	PLUG, 25	1							
11	2	119717-42320	O-RING, P26	1							
11-1	2	119C10-42320	O-RING, 2028	1							S
(A=E/ B4768)											
12	2	129916-49740	PLUG, R03	1							
13	1	119717-42020	GASKET, WATER PUMP	1							
14	1	23414-080000	GASKET, 8X1.0	1							
15	1	26106-080122	BOLT, M8X 12 PLATED	1							
16	1	26106-080502	BOLT, M8X 50 PLATED	3							
17	1	119740-42350	V-PULLEY, D=90	1							
18	1	171001-42290	V-BELT, A35.5	1							
19	1	26106-060122	BOLT, M6X 12 PLATED	4							
20	1	124101-49531	COVER, THERMOSTAT	1							
21	1	119717-49800	THERMOSTAT, 71	1							
22	1	26106-080252	BOLT, M8X 25 PLATED	1							
23	1	121450-42450	PLUG, M16	1							
24	1	121250-44901	SWITCH, 110	1							
25	1	124465-44950	GASKET, 16	2							
26	1	26106-080602	BOLT, M8X 60 PLATED	1							
27	1	119620-49290	COCK ASSY, 1/4	1							
31	1	124450-44550	BAND	1							
32	1	121256-44600	BRACKET, SUB TANK	1							
33	1	124450-44510	TANK ASSY, SUB	1							
35	2	124450-44530	CAP	1							
36	2	124450-44560	RETAINER	1							
37	2	23061-070230	PIPE, 7X 230	1							

Fig.9. FUEL INJECTION PUMP

(A)=3TNV76-GMA

(B)=

(C)=

(D)=

(E)=

(F)=

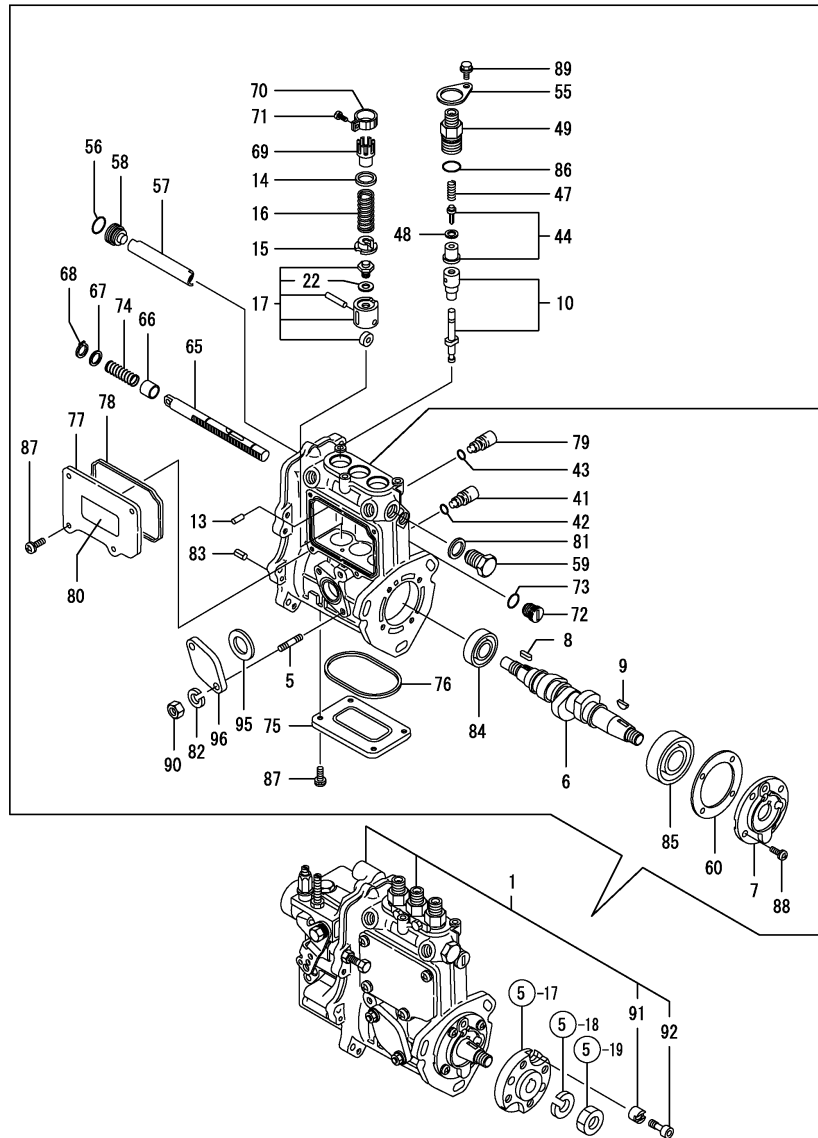

No.	Lev.	Parts No.	Description	Q'ty						I	R
				(A)	(B)	(C)	(D)	(E)	(F)		
1	1	719746-51370	PUMP ASSY, INJECTION	1							1
5	2	129155-51020	STUD	2							
6	2	119717-51030	CAMSHAFT	1							
7	2	119717-51060	SUPPORT, CAMSHAFT	1							
8	2	119717-51070	KEY	1							
9	2	122710-51090	KEY	1							
10	2	119717-51100	PLUNGER ASSY	3							
13	2	129155-51140	PIN	3							
14	2	158600-51170	RETAINER, SPRING	3							
15	2	119717-51570	RETAINER, SPRING	3							
16	2	119717-51190	SPRING, PLUNGER	3							
17	2	119717-51200	TAPPET ASSY	3							
22	3	129155-51600	SHIM SET, ADJUSTING	1							
41	2	158600-51270	STOPPER, TAPPET	3							
42	2	129155-51280	O-RING, S6	3							
43	2	129155-51280	O-RING, S6	1							
44	2	119717-51300	VALVE ASSY, DELIVERY	3							
47	2	119717-51330	SPRING, DELIVERY	3							
48	2	124550-51350	GASKET, DELIVERY	3							
49	2	158600-51442	VALVE ASSY, DELIVERY	3							
55	2	118400-51370	LOCKING	3							
56	2	119717-51420	O-RING	1							
57	2	129155-51400	DEFLECTOR	1							
58	2	158600-51410	PLUG, DEFLECTOR	1							
59	2	158600-51420	PLUG, DEFLECTOR	1							
60	2	129155-51450	SHIM SET, ADJUSTING	1							
65	2	119717-51500	RACK, CONTROL	1							
66	2	129155-51521	BUSH, RACK	1							
67	2	129155-51530	SPACER	1							
68	2	129155-51540	CIRCLIP	1							
69	2	129155-51550	PINION, CONTROL	3							
70	2	129100-51560	PINION	3							
71	2	129100-51570	SCREW	3							
72	2	158600-51570	PLUG	1							
73	2	129155-51580	O-RING	1							
74	2	129155-51591	SPRING, RACK	1							
75	2	129155-51701	COVER	1							
76	2	119717-51710	GASKET	1							
77	2	119717-51750	COVER	1							
78	2	119717-51760	GASKET	1							
79	2	158600-51790	STOOPER, RACK	1							
80	2	129156-51910	LABEL, CAUTION	1							
81	2	22190-160002	WASHER, SEAL 16	1							
82	2	22217-060000	WASHER, SPRING 6	2							
83	2	22351-050010	PIN, SPRING 5.0X10	2							
84	2	24101-060034	BEARING, BALL 6003	1							
85	2	24101-063034	BEARING, BALL 6303	1							
86	2	24316-000150	O-RING, 4DP15.0	3							
87	2	26022-050122	SCREW, M5X12	8							
88	2	26022-060162	SCREW, M6X16	4							
89	2	26106-050102	BOLT, M5X 10 PLATED	3							

Remarks
 (1) GOVERNOR ASSY(FIG.10) IS
 INCORPORATED IN THIS FOP.CMP
 (REF.NO.1).

Fig.9. FUEL INJECTION PUMP

(A)=3TNV76-GMA

(B)=

(C)=

(D)=

(E)=

(F)=

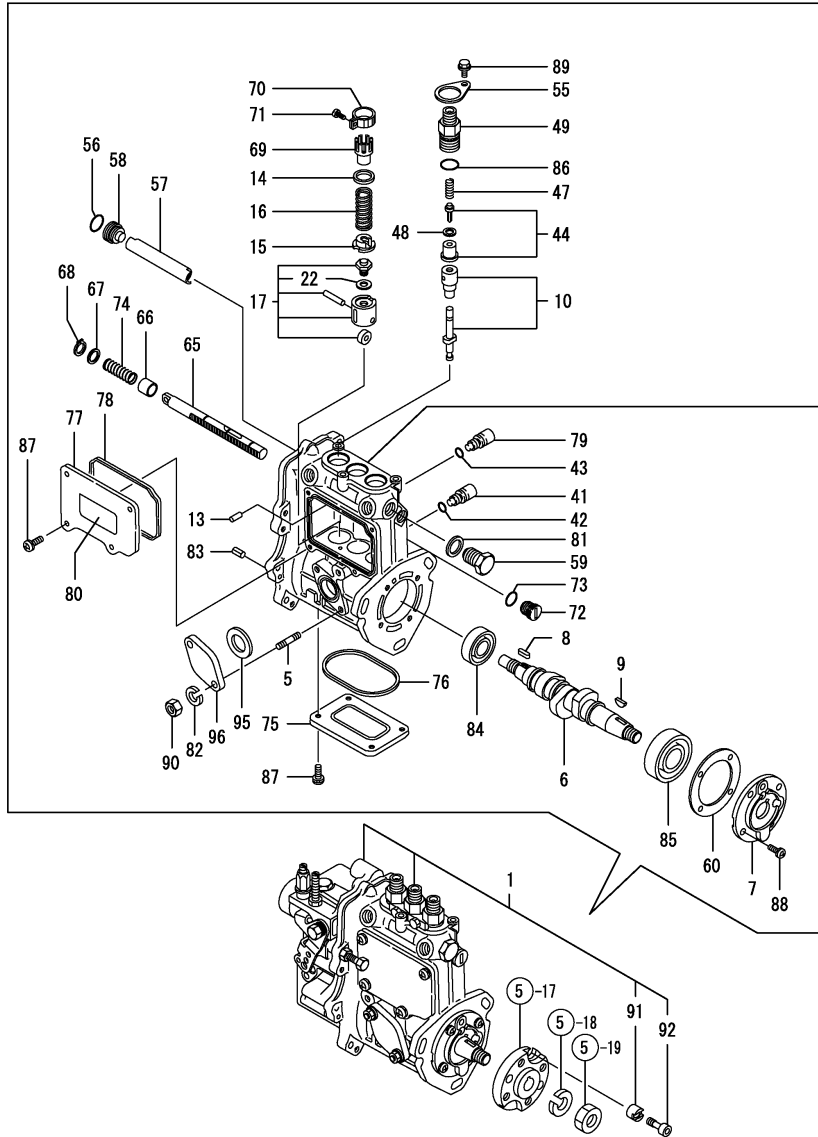

No.	Lev.	Parts No.	Description	Q'ty						I	R
				(A)	(B)	(C)	(D)	(E)	(F)		
90	2	26716-060002	NUT, M6	2							
91	2	119717-51480	COLLAR	1							
92	2	119717-51490	BOLT	1							
95	2	129155-52051	GASKET	1							
96	2	129100-52200	COVER	1							

Remarks
 (1) GOVERNOR ASSY(FIG.10) IS
 INCORPORATED IN THIS FOP.CMP
 (REF.NO.1).

Fig.10. GOVERNOR

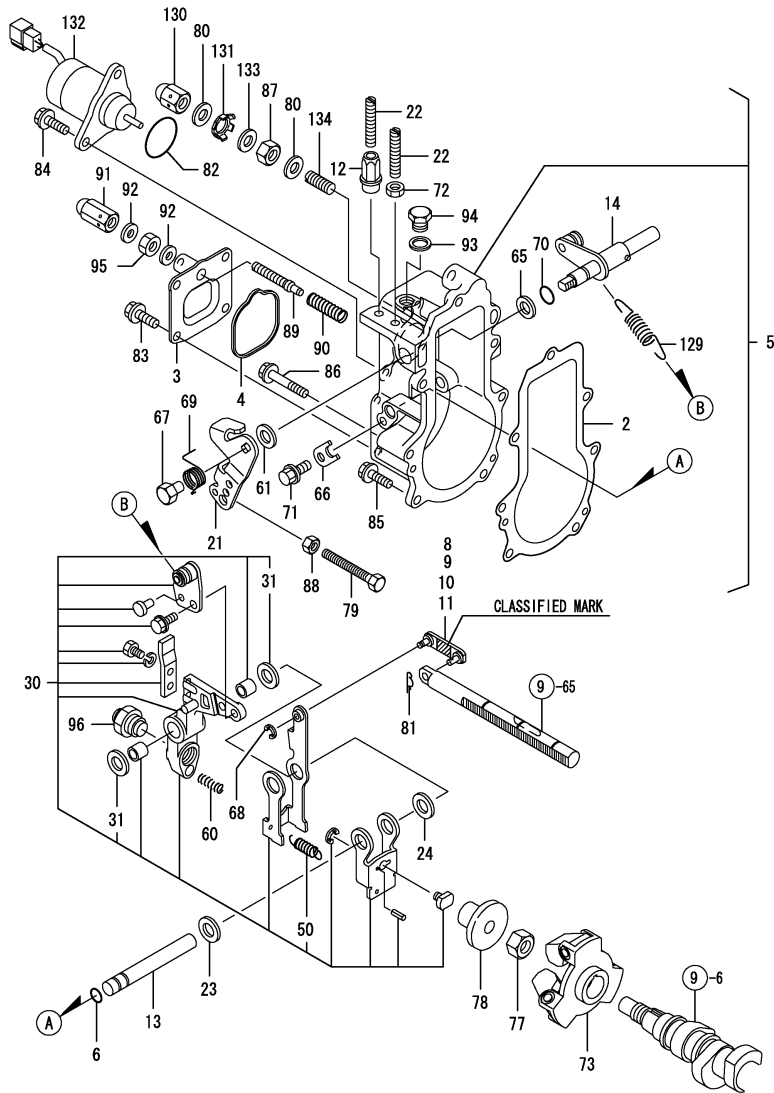

(A)=3TNV76-GMA

(B)=

(C)=

(D)=

(E)=

(F)=

No.	Lev.	Parts No.	Description	Q'ty						I	R
				(A)	(B)	(C)	(D)	(E)	(F)		
2	2	119717-61050	GASKET	1							
3	2	119746-61060	COVER, GOVERNOR CASE	1							
4	2	119717-61070	GASKET	1							
5	2	119546-61100	CASE ASSY, GOVERNOR	1							
6	3	129155-51280	O-RING, S6	1							
8	3	119717-61120	LINK, MARK :3	1							1
9	3	119717-61130	LINK, MARK 98	1							1
10	3	119717-61140	LINK, MARK 88	1							1
11	3	119717-61150	LINK, MARK 03	1							1
12	3	129209-61370	NUT, M6	1							
13	3	129052-61390	SHAFT	1							
14	3	119717-61400	SHAFT ASSY	1							
21	3	119746-61440	LEVER, CONTROL	1							
22	3	129155-61450	BOLT, LIMITER	2							
23	3	129156-61460	SHIM, T=0.6	1							
24	3	129155-61480	SPACER ASSY	1							
30	3	119746-61500	LEVER ASSY, GOVERNOR	1							
31	4	174307-51700	SHIM SET	2							
50	4	129486-61540	SPRING, SET	1							
60	3	129486-61650	SPRING, STARTING	1							
61	3	158552-61700	SHIM SET	1							
65	3	158552-61710	SHIM, T=1.0	1							
66	3	119660-61901	RETAINER, SHAFT	1							
67	3	129255-61410	NUT, LOCK	1							
68	3	22272-000030	RING, E- 3	1							
69	3	119527-61420	SPRING	1							
70	3	24341-000070	O-RING, 1AS7.0	1							
71	3	26106-060102	BOLT, M6X 10 PLATED	1							
72	3	26756-060002	NUT, LOCK M6	1							
73	2	119717-61200	WEIGHT ASSY,GOVERNOR	1							
77	2	119660-61300	NUT	1							
78	2	129155-61341	SLEEVE	1							
79	2	129155-61460	BOLT, IDLE	1							
80	2	22190-120002	WASHER, SEAL 12	2							
81	2	22372-040000	PIN, SNAP 4	1							
82	2	24341-000280	O-RING, 1AS28.0	1							
82-1	2	158552-61900	O-RING	1							N
(A=EXXXXX)											
83	2	26106-060102	BOLT, M6X 10 PLATED	4							
84	2	26106-060142	BOLT, M6X 14 PLATED	2							
85	2	26106-060202	BOLT, M6X 20 PLATED	4							
86	2	26106-060452	BOLT, M6X 45 PLATED	3							
87	2	26736-120002	NUT, M12	1							
88	2	26756-060002	NUT, LOCK M6	1							
89	2	119645-61070	SCREW	1							
90	2	119746-61080	SPRING	1							
91	2	119600-66840	NUT, CAP	1							
92	2	22190-060003	SEAL WASER 6	2							
93	2	22190-100002	WASHER, SEAL 10	1							
94	2	23887-100002	PLUG, 10	1							
95	2	26756-060002	NUT, LOCK M6	1							

Remarks

(1) SELECTIVE PARTS: CERTAIN THE CLASSIFICATION MARK, THEN PLACE YOUR ORDER.(REF. TO ILLUSTRATION)
* THIS FIGURE(GOVERNOR ASSY)IS INCORPORATED IN THE FUEL INJECTION PUMP ASSY(FIG.9).

Fig.10. GOVERNOR

(A)=3TNV76-GMA

(B)=

(C)=

(D)=

(E)=

(F)=

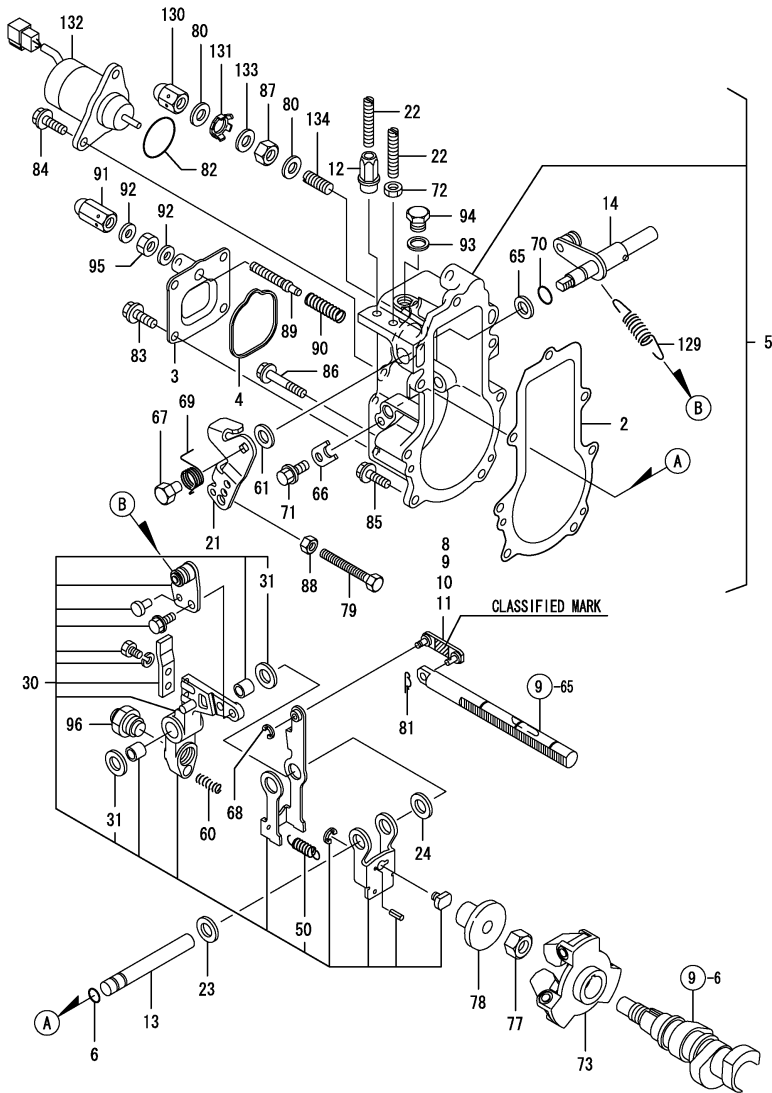

No.	Lev.	Parts No.	Description	Q'ty						I	R
				(A)	(B)	(C)	(D)	(E)	(F)		
96	2	119746-61550	ANGLEICH ASSY	1							
129	2	119542-61700	SPRING, GOVERNOR	1							
130	2	129209-61930	NUT, CAP	1							
131	2	129209-61970	PLATE	1							
132	2	119653-77950	SOLENOID, STOP	1							
133	2	23414-120016	GASKET, 12X1.0	1							
134	2	129155-61470	BOLT, CONTROL	1							

Remarks

(1) SELECTIVE PARTS: CERTAIN THE CLASSIFICATION MARK, THEN PLACE YOUR ORDER.(REF. TO ILLUSTRATION)
 * THIS FIGURE(GOVERNOR ASSY)IS INCORPORATED IN THE FUEL INJECTION PUMP ASSY(FIG.9).

Fig.11. FUEL INJECTION VALVE

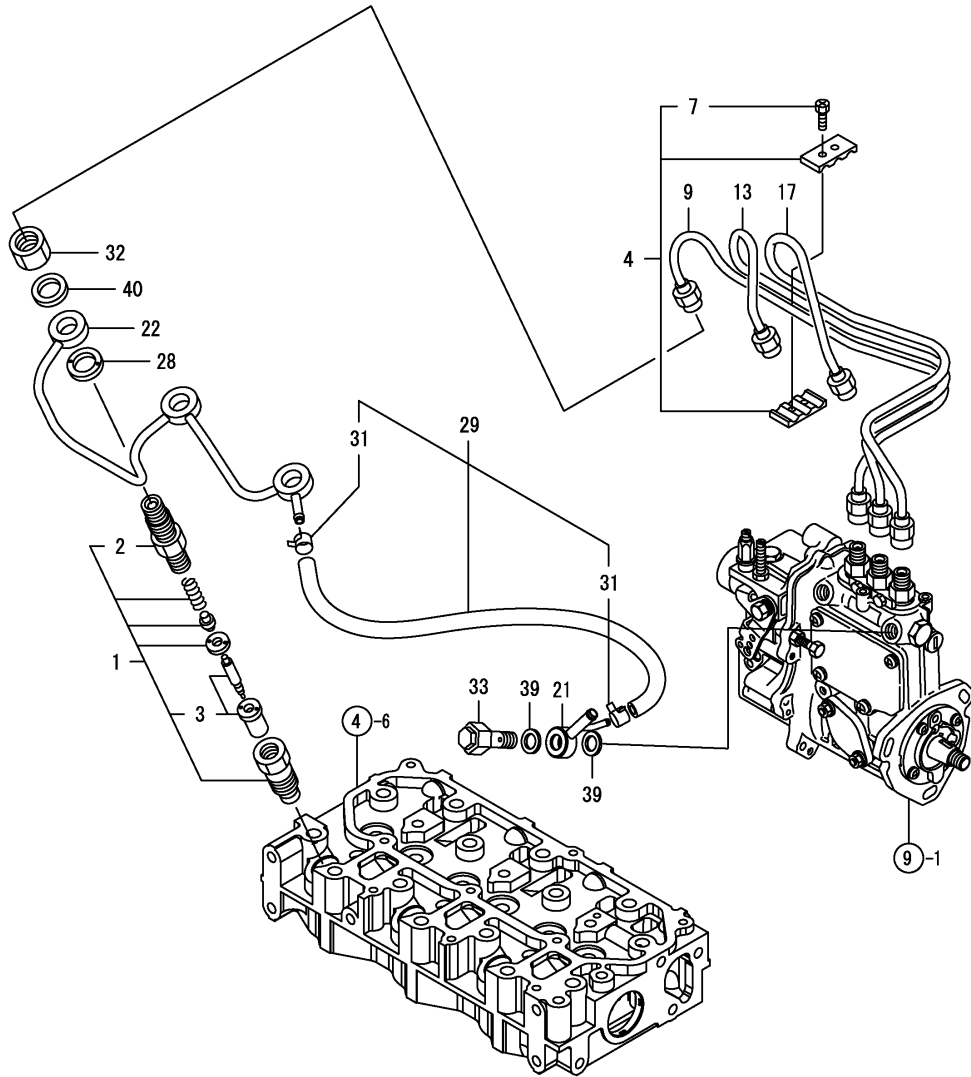

(A)=3TNV76-GMA
(B)=
(C)=

(D)=
(E)=
(F)=

No.	Lev.	Parts No.	Description	Qty						I	R
				(A)	(B)	(C)	(D)	(E)	(F)		
1	1	119717-53001	VALVE ASSY,INJECTION	3							
2	2	118200-53010	HOLDER, NOZZLE	3							
3	2	119717-53010	VALVE ASSY,INJECTION	3							
4	1	129150-59120	RETAINER, PIPE	1							
7	2	129150-59131	BOLT, M4X14	2							
9	1	119717-59810	PIPE ASSY, INJECTION	1							
13	1	119717-59820	PIPE ASSY, INJECTION	1							
17	1	119717-59830	PIPE ASSY, INJECTION	1							
21	1	119840-59570	JOINT	1							
22	1	119717-59510	PIPE ASSY, RETURN	1							
28	1	129901-59560	GASKET	3							
29	1	119540-59570	PIPE ASSY, RETURN	1							
31	2	124066-59100	CLIP, HOSE 8	2							
32	1	119620-59700	NUT, NOZZLE	3							
33	1	119813-59950	VALVE ASSY, CHECK	1							
39	1	22190-120002	WASHER, SEAL 12	2							
40	1	22190-120002	WASHER, SEAL 12	3							

Fig.12. FUEL LINE

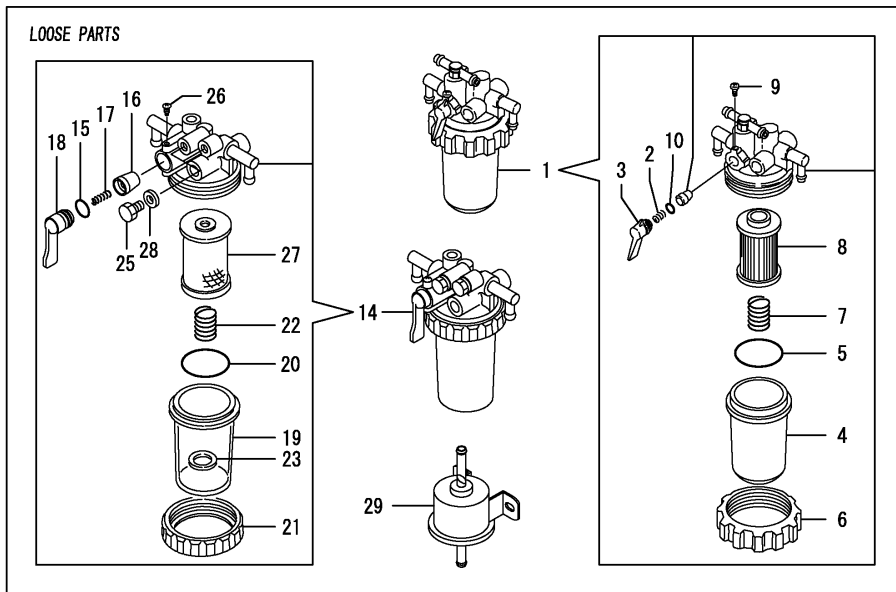
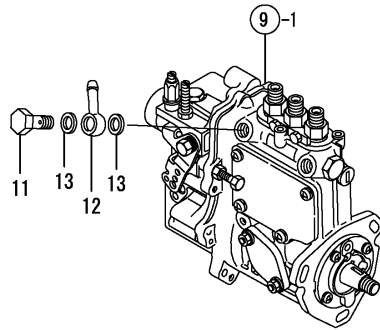

(A)=3TNV76-GMA

(B)=

(C)=

(D)=

(E)=

(F)=

No.	Lev.	Parts No.	Description	Q'ty						I	R
				(A)	(B)	(C)	(D)	(E)	(F)		
1	1	119833-55620	FILTER ASSY, FUEL	1							
2	2	104200-55330	SPRING, VALVE	1							
3	2	119810-55340	LEVER	1							
4	2	121254-55510	COVER	1							
5	2	102103-55520	O-RING	1							
6	2	110250-55610	RING, RETAINING	1							
7	2	121250-55620	SPRING	1							
8	2	119810-55650	ELEMENT	1							
9	2	104200-55750	SCREW, M4	1							
10	2	24311-240100	O-RING, 1AP10A	1							
11	1	103854-39140	BOLT, PIPE JOINT	1							
12	1	101304-59020	JOINT, PIPE 12	1							
13	1	22190-120002	WASHER, SEAL 12	2							
14	1	129335-55700	SEPARATOR ASSY,WATER	1							
15	2	24311-240100	O-RING, 1AP10A	1							
16	2	104200-55321	VALVE, TAPER	1							
17	2	104200-55330	SPRING, VALVE	1							
18	2	104200-55341	HANDLE	1							
19	2	124064-55510	COVER	1							
20	2	102103-55520	O-RING	1							
21	2	110250-55610	RING, RETAINING	1							
22	2	121257-55720	SPRING	1							
23	2	121257-55731	FLOAT	1							
25	2	101720-55750	PLUG, 6	2							
26	2	104200-55750	SCREW, M4	1							
27	2	171081-55910	SCREEN	1							
28	2	23418-060000	GASKET, 6X1.0	2							
29	1	119225-52102	PUMP ASSY, FUEL FEED	1							

Fig.13. STARTING MOTOR

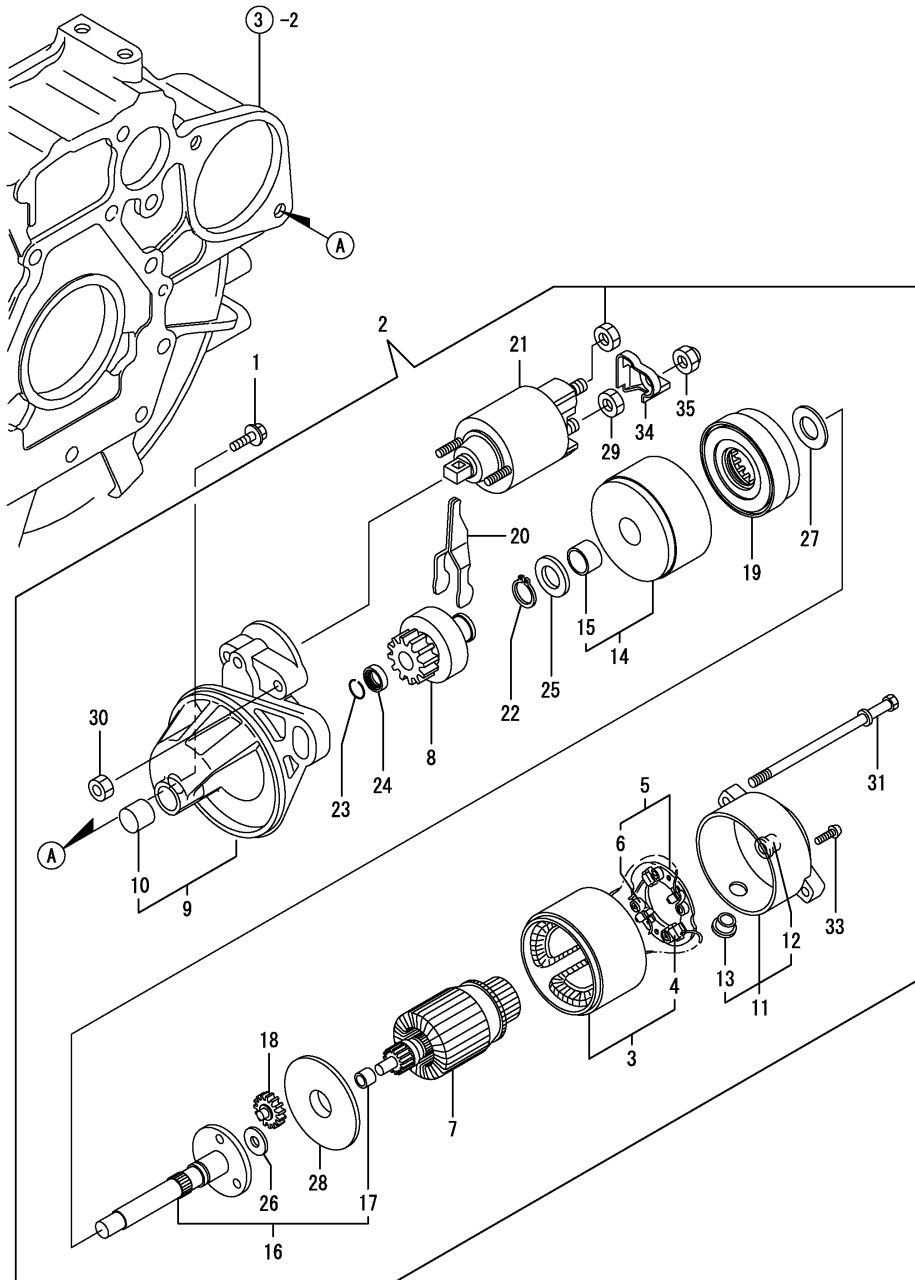

(A)=3TNV76-GMA

(B)=

(C)=

(D)=

(E)=

(F)=

No.	Lev.	Parts No.	Description	Q'ty						I	R
				(A)	(B)	(C)	(D)	(E)	(F)		
1	1	26106-100252	BOLT, M10X 25 PLATED	2							
2	1	119717-77010	STARTER, P1.1	1							
3	2	X0281007750	YOKE ASSY	1							
4	3	X0280996180	STARTER KIT	2							
5	2	X0285105190	HOLDER ASSY	1							
6	3	X0285205030	SPRING	4							
7	2	X0282005991	ARMATURE ASSY	1							
8	2	X0283006960	CLUTCH ASSY	1							
9	2	X4284001590	HOUSING ASSY,STARTER	1							
10	3	X9491050100	BEARING, NEEDLE	1							
11	2	X0285007030	FRAME ASSY.	1							
12	3	X9491040990	BEARING	1							
13	3	X0280626010	COVER	1							
14	2	X0284105040	BEARING ASSY	1							
15	3	X9491034330	BEARING	1							
16	2	X0286105010	SHAFT ASSY	1							
17	3	X9491034320	BEARING	1							
18	2	X0286305010	GEAR	3							
19	2	X0286355010	GEAR	1							
20	2	X0287405140	LEVER	1							
21	2	X0534007800	SWITCH ASSY	1							
22	2	X9055715000	RING	1							
23	2	X9490721360	RING	1							
24	2	X0280210331	NUT	1							
25	2	X9490138110	WASHER	1							
26	2	X9490138090	WASHER	1							
27	2	X9490138100	WASHER	1							
28	2	X0284525010	PLATE	1							
29	2	X9490562360	NUT	1							
30	2	X9490560750	NUT	2							
31	2	X9490423420	BOLT, THROUGH	2							
33	2	X9490065670	SCREW, M4X6	2							
34	2	X0280335350	COVER, TERMINAL	1							
35	2	X1289510130	NUT	1							

Fig.14. GENERATOR

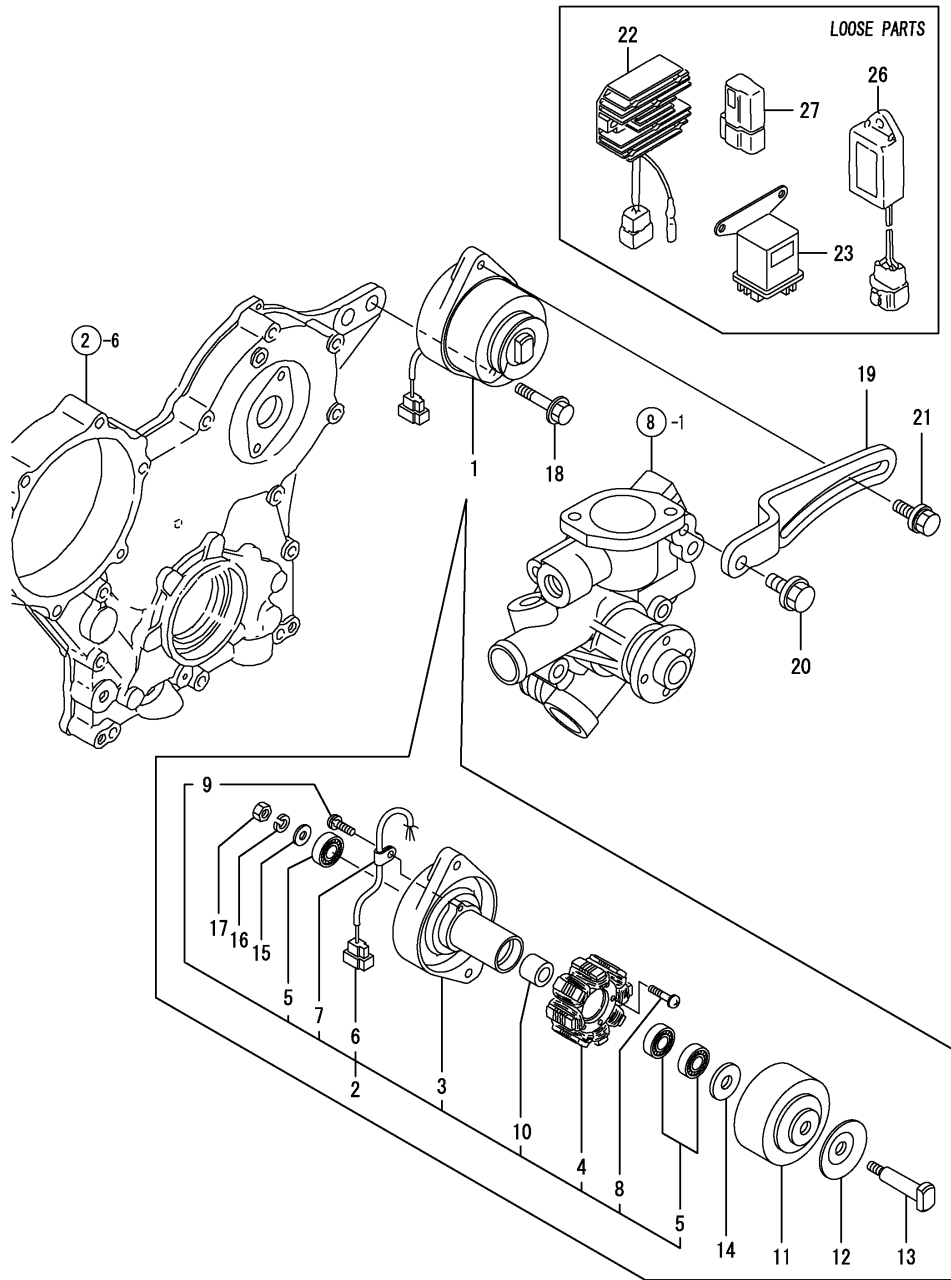

(A)=3TNV76-GMA

(B)=

(C)=

(D)=

(E)=

(F)=

No.	Lev.	Parts No.	Description	Q'ty						I	R
				(A)	(B)	(C)	(D)	(E)	(F)		
1	1	171301-77201	DYNAMO ASSY, 15A	1							
2	2	XM08137	PLATE ASSY	1							
3	3	X2A07073KA	PLATE	1							
4	3	X4A07023KB	STATOR ASSY	1							
5	3	24104-062010	BEARING, 6201UUC3	3							
6	3	X417878	COUPLER	1							
7	3	XM069000000	CLAMP	1							
8	3	XYSPTS402400	SCREW	2							
9	3	XYSPTS400800	SCREW	1							
10	3	XM329830000	COLLAR	1							
11	2	X3A08877KA	FLYWHEEL	1							
12	2	XM721740000	PULLEY	1							
13	2	X4A07403K01	SHAFT	1							
14	2	XM67935	WASHER	1							
15	2	XM860250000	WASHER 10	1							
16	2	XM219230000	WASHER, SPRING	1							
17	2	XM863720000	NUT	1							
18	1	26106-100402	BOLT, M10X 40 PLATED	1							
19	1	119746-77330	ADJUSTER	1							
20	1	26106-080202	BOLT, M8X 20 PLATED	1							
21	1	119810-77340	BOLT, ADJUSTER	1							
22	1	119653-77710	LIMITER, CURRENT	1							
23	1	119650-77910	RELAY ASSY, GLOW	1							
26	1	129211-77920	TIMER	1							
27	1	119643-66900	DIODE	1							

Fig.15. GASKET SET

(A)=3TNV76-GMA

(B)=

(C)=

(D)=

(E)=

(F)=

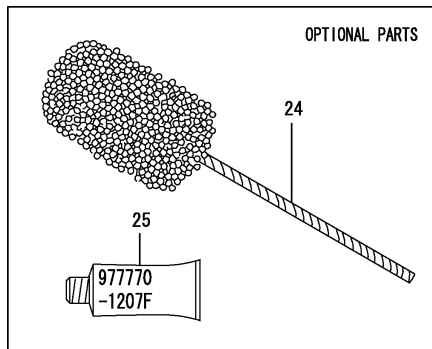
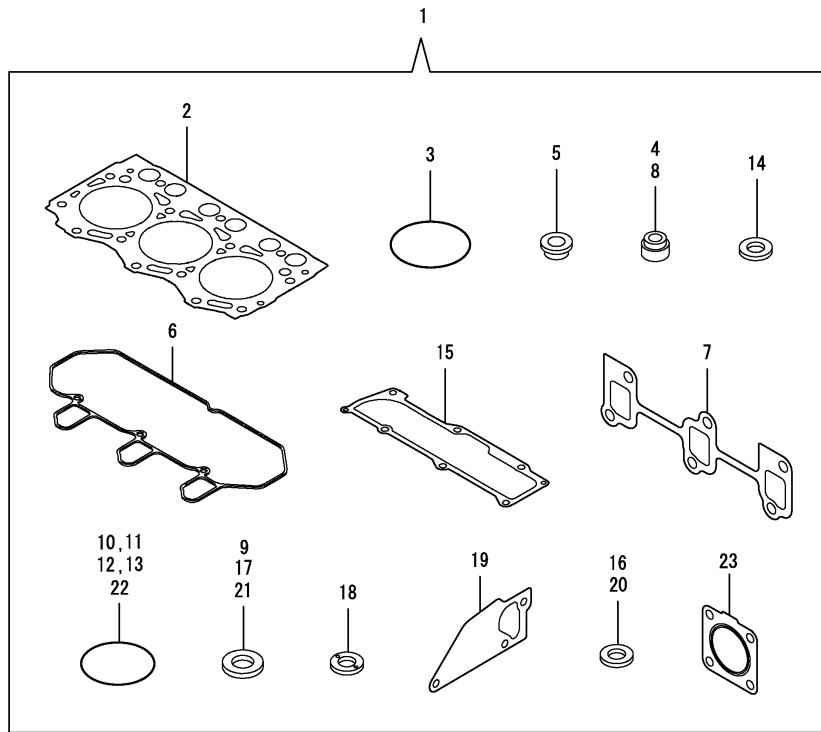

No.	Lev.	Parts No.	Description	Q'ty						I	R
				(A)	(B)	(C)	(D)	(E)	(F)		
1	1	719717-92760	GASKET SET	1							1
2	2	119717-01330	GASKET, HEAD	1							
3	2	121850-51960	O-RING	1							
4	2	119717-11340	SEAL, VALVE STEM	3							
5	2	129901-11450	PROTECTOR, NOZZLE	3							
6	2	119718-11310	GASKET, BONNET	1							
7	2	119717-13110	GASKET	1							
8	2	119717-11350	SEAL, VALVE STEM	3							
9	2	22190-080002	WASHER, SEAL 6	4							
10	2	24311-000320	O-RING, 1AP32.0	2							
11	2	119717-32060	O-RING, P15.0	1							
12	2	119624-32040	O-RING, P12.0	1							
13	2	119717-32050	O-RING, P17.0	3							
14	2	119600-11460	GASKET, NOZZLE	6							
15	2	119717-11331	GASKET	1							
16	2	124465-44950	GASKET, 16	2							
17	2	22190-120002	WASHER, SEAL 12	7							
18	2	129901-59560	GASKET	3							
19	2	119717-42020	GASKET, WATER PUMP	1							
20	2	23414-080000	GASKET, 8X1.0	1							
21	2	22190-160002	WASHER, SEAL 16	1							
22	2	24341-000240	O-RING, 1AS24.0	1							
23	2	119515-13200	GASKET, SILENCER	1							
24	1	129400-92420	FLEX HORN	1							1
25	1	977770-1207F	GASKET.LIQUID	1							1

Remarks
(1) OPTIONAL PARTS.

Parts No. Index

Parts No.	Fig. No.	Ref. No.
101304-59020	12	12
101720-55750	12	25
102103-55520	12	5
		20
103854-39140	12	11
104200-55321	12	16
104200-55330	12	2
		17
104200-55341	12	18
104200-55750	12	9
		26
105010-11490	4	5
105311-01090	1	6
105425-01690	3	7
110250-55610	12	6
		21
114250-39450	7	10
118200-53010	11	2
118400-51370	9	55
119225-52102	12	29
119285-01990	1	9
119285-11990	4	15
119305-35151	7	3
119515-13200	4	63
	15	23
119527-61420	10	69
119540-59570	11	29
119542-61700	10	129
119546-61100	10	5
119600-11460	4	4
	15	14
119600-66840	10	91
119620-01750	3	13
119620-01800	2	8
119620-02020	1	10
119620-11280	4	30
119620-14200	5	1
119620-21941	6	14
119620-49290	8	27
119620-59700	11	32
119621-21680	6	13
119623-01250	1	7
119624-32040	2	20
	15	12
119636-21590	6	8
119643-66900	14	27
119645-61070	10	89
119650-77910	14	23
119653-77710	14	22
119653-77950	10	132

Parts No.	Fig. No.	Ref. No.
119660-01911	2	19
119660-61300	10	77
119660-61901	10	66
119717-01330	1	31
	15	2
119717-01501	2	1
119717-01570	2	3
119717-01601	3	2
119717-01720	3	4
119717-01750	2	18
119717-01770	3	6
119717-02410	1	13
119717-03031	4	40
119717-03070	4	41
		42
119717-11100	4	17
119717-11110	4	18
119717-11131	4	19
119717-11190	4	21
119717-11200	4	25
119717-11240	4	26
119717-11260	4	29
119717-11320	4	51
119717-11331	4	52
	15	15
119717-11340	4	22
	15	4
119717-11350	4	23
	15	8
119717-11381	4	39
119717-11650	4	31
119717-11740	4	6
119717-11800	4	14
119717-13110	4	62
	15	7
119717-14400	5	2
119717-14580	5	3
119717-21200	6	6
119717-21650	6	12
119717-21700	6	1
119717-22080	6	15
119717-22300	6	21
119717-22500	6	17
119717-22550	6	33
119717-22900	6	31
119717-23000	6	23
119717-23200	6	28
119717-23600	6	40
119717-23610	6	37
119717-23910	6	27

Parts No.	Fig. No.	Ref. No.
119717-25050	5	10
119717-25100	5	11
119717-25930	5	16
119717-32050	2	21
	15	13
119717-32060	7	4
	15	11
119717-32080	2	11
119717-32100	2	10
119717-32110	2	15
119717-32120	2	16
119717-34801	7	1
119717-35080	7	5
119717-39210	7	11
119717-42002	8	1
119717-42020	8	13
	15	19
119717-42031	8	4
119717-42041	8	3
119717-42320	8	11
119717-49800	8	21
119717-51030	9	6
119717-51060	9	7
119717-51070	9	8
119717-51100	9	10
119717-51150	5	17
119717-51190	9	16
119717-51200	9	17
119717-51300	9	44
119717-51330	9	47
119717-51420	9	56
119717-51480	9	91
119717-51490	9	92
119717-51500	9	65
119717-51570	9	15
119717-51710	9	76
119717-51750	9	77
119717-51760	9	78
119717-53001	11	1
119717-53010	11	3
119717-59510	11	22
119717-59810	11	9
119717-59820	11	13
119717-59830	11	17
119717-61050	10	2
119717-61070	10	4
119717-61120	10	8
119717-61130	10	9
119717-61140	10	10
119717-61150	10	11

Parts No.	Fig. No.	Ref. No.
119717-61200	10	73
119717-61400	10	14
119717-77010	13	2
119717-77800	4	59
119717-77820	4	60
119718-11310	4	50
	15	6
119740-42350	8	17
119744-01521	2	6
119744-01590	2	4
119746-61060	10	3
119746-61080	10	90
119746-61440	10	21
119746-61500	10	30
119746-61550	10	96
119746-77330	14	19
119802-03100	4	43
119802-03110	4	44
119802-03121	4	45
119802-03131	4	46
119802-03141	4	47
119802-32130	2	17
119810-01200	1	30
119810-02930	1	27
119810-02940	1	32
119810-55340	12	3
119810-55650	12	8
119810-77340	14	21
119813-59950	11	33
119833-55620	12	1
119840-59570	11	21
119865-21600	6	11
119C10-42320	8	11 -1
119E10-42000	8	1 -1
121023-01551	2	33
121111-21501	6	39
121120-01620	3	15
121250-44901	8	24
121250-55620	12	7
121254-55510	12	4
121256-44600	8	32
121257-55720	12	22
121257-55731	12	23
121450-42450	8	23
121520-34810	7	16
121850-51960	2	22
	15	3
122710-51090	9	9
124060-01050	1	5
	7	17

Parts No. Index

Parts No.	Fig. No.	Ref. No.
124064-55510	12	19
124066-59100	11	31
124085-02220	3	3
124101-49531	8	20
124160-01751	2	31
	4	38
124160-01910	1	8
124450-44510	8	33
124450-44530	8	35
124450-44550	8	31
124450-44560	8	36
124465-44950	8	25
	15	16
124550-51350	9	48
129001-32320	2	13
129001-32330	2	14
129005-59830	7	12
129052-61390	10	13
129100-01580	3	1
	6	2
129100-35140	7	2
129100-51560	9	70
129100-51570	9	71
129100-52200	9	96
129150-11230	4	32
129150-11750	4	34
129150-25301	5	15
129150-59120	11	4
129150-59131	11	7
129155-51020	9	5
129155-51140	9	13
129155-51280	9	42
		43
	10	6
129155-51400	9	57
129155-51450	9	60
129155-51521	9	66
129155-51530	9	67
129155-51540	9	68
129155-51550	9	69
129155-51580	9	73
129155-51591	9	74
129155-51600	9	22
129155-51701	9	75
129155-52051	9	95
129155-61341	10	78
129155-61450	10	22
129155-61460	10	79
129155-61470	10	134
129155-61480	10	24

Parts No.	Fig. No.	Ref. No.
129156-51910	9	80
129156-61460	10	23
129209-61370	10	12
129209-61930	10	130
129209-61970	10	131
129211-77920	14	26
129255-61410	10	67
129335-55700	12	14
129400-92420	15	24
129486-61540	10	50
129486-61650	10	60
129508-11180	4	20
129900-07900	4	1
129900-32130	2	12
129901-11450	4	3
	15	5
129901-59560	11	28
	15	18
129916-49740	8	12
158552-61700	10	61
158552-61710	10	65
158552-61900	10	82 -1
158600-51170	9	14
158600-51270	9	41
158600-51410	9	58
158600-51420	9	59
158600-51442	9	49
158600-51570	9	72
158600-51790	9	79
171001-42290	8	18
171081-55910	12	27
171301-77201	14	1
171375-39601	7	18
174307-51700	10	31
22190-060003	10	92
22190-080002	7	13
		15
	15	9
22190-100002	10	93
22190-120002	10	80
	11	39
		40
	12	13
	15	17
22190-160002	3	9
	9	81
	15	21
22217-060000	9	82
22217-120000	5	18
22242-000120	4	35

Parts No.	Fig. No.	Ref. No.
22252-000220	6	22
22272-000030	10	68
22351-050010	9	83
22351-060012	4	24
22372-040000	10	81
22512-040120	6	5
22857-500100	4	53
		54
22857-500160	4	55
23061-070230	8	37
23414-080000	8	14
	15	20
23414-120016	10	133
23418-060000	12	28
23857-030000	7	14
23876-005000	4	16
23876-030000	2	9
23887-100002	10	94
24101-060034	9	84
24101-063034	9	85
24104-062010	14	5
24311-000320	2	32
	4	56
	15	10
24311-240100	12	10
		15
24316-000150	9	86
24341-000070	10	70
24341-000240	2	34
	15	22
24341-000280	10	82
26022-050122	9	87
26022-060162	9	88
26106-050102	9	89
26106-060102	7	9
	10	71
		83
26106-060122	2	23
	5	9
	8	19
26106-060142	10	84
26106-060162	2	24
		35
26106-060202	4	57
	10	85
26106-060352	5	14
26106-060402	2	25
		26
26106-060452	10	86
26106-060602	2	27

Parts No.	Fig. No.	Ref. No.
26106-060652	2	28
26106-060752	4	58
26106-080122	3	10
	8	15
26106-080162	4	2
26106-080202	14	20
26106-080252	8	22
26106-080302	3	11
26106-080402	4	37
26106-080452	3	12
26106-080502	3	17
	8	16
26106-080602	8	26
26106-100252	13	1
26106-100402	14	18
26206-100252	3	14
26306-080002	2	29
26577-060122	8	9
26716-060002	9	90
26716-120002	5	19
26736-120002	10	87
26756-060002	10	72
		88
		95
26979-050162	4	36
27241-120000	1	14
27241-250000	8	10
719717-01561	1	1
719717-02900	1	15
719717-02910	1	35
719717-92760	15	1
719744-01500	2	5
719746-51370	9	1
977770-1207F	2	30
	3	16
	4	61
	15	25
X0280210331	13	24
X0280335350	13	34
X0280626010	13	13
X0280996180	13	4
X0281007750	13	3
X0282005991	13	7
X0283006960	13	8
X0284105040	13	14
X0284525010	13	28
X0285007030	13	11
X0285105190	13	5
X0285205030	13	6
X0286105010	13	16

Parts No. Index

Parts No.	Fig. No.	Ref. No.
X0286305010	13	18
X0286355010	13	19
X0287405140	13	20
X0534007800	13	21
X1289510130	13	35
X2A07073KA	14	3
X3A08877KA	14	11
X417878	14	6
X4284001590	13	9
X4A07023KB	14	4
X4A07403K01	14	13
X9055715000	13	22
X9490065670	13	33
X9490138090	13	26
X9490138100	13	27
X9490138110	13	25
X9490423420	13	31
X9490560750	13	30
X9490562360	13	29
X9490721360	13	23
X9491034320	13	17
X9491034330	13	15
X9491040990	13	12
X9491050100	13	10
XM069000000	14	7
XM08137	14	2
XM219230000	14	16
XM329830000	14	10
XM67935	14	14
XM721740000	14	12
XM860250000	14	15
XM863720000	14	17
XYSPS400800	14	9
XYSPS402400	14	8

Parts No.	Fig. No.	Ref. No.
-----------	----------	----------

Parts No.	Fig. No.	Ref. No.
-----------	----------	----------

Parts No.	Fig. No.	Ref. No.
-----------	----------	----------