

0CW10-M80100EN

P R E F A C E

1. This parts catalog is the 1st edition of 3TNV80F-SSNS2 for NEUSON.

Pub. No. : 0CW10-G80100

Published : January, 2013

2. Model name

Engine model	Vehicle	Vehicle made by
3TNV80F-SSNS2	EXCAVATOR	NEUSON

Directions for the Parts Catalog.

1. This Parts Catalog shows both standard and optional parts.
2. Parts may change without prior notice.
3. The following is an example of the Parts Catalog format.

REF.	LEV.	PARTS NO.	DESCRIPTION	Q'TY						I	R
				(A)	(B)	(C)	(D)	(E)	(F)		
1	1	729595-51390	FUEL INJECTION PUMP	1	1	1	1	1			1
1-1	1	729595-51391	FUEL INJECTION PUMP	1	1	1	1	1		N	1
		(A=E00185) (B=E00200)									
3	2	26022-060162	SCREW M 6X 16	9	9	9	9	9			
3-1	2	26022-060162	SCREW M 6X 16	4	4	4	4	4		K	
		(A=E00156) (B=E00156) (C=E00156) (D=E00156) (E=E00156)									
4	2	129470-51040	CAMSHAFT	1	1	1	1	1			
5	2	122710-51050	BEARING, ROLLER	2	2	2	2	2			
6	2	129470-51060	RETAINER	1	1	1	1	1			

Remarks
(1) BOOST COMPEMSATOR TYPE. OPTIONAL PART, TO E00155,(4JH-DT, 4JH-DTZ

① Ref. No.

The Ref. No. listed may not be in accordance with the illustration Ref. No.

(Ex.) Illustration No.

List Ref No.

1

1

(Before change)

1-1

(After change)

For interchangeable symbols N, R and K, illustrations for new parts may be abbreviated.

② Lev. (Level)

Level indication

The numbers below indicate the level of relativity towards the main part.

1 ----- Main parts (Assembly parts)

2 ----- Sub component included in " 1 ".

3 ----- Sub component included in " 2 ".

Note) Parts that are not for sale are partially illustrated but not listed.

③ Interchangeability Symbol

When a part change takes place, one of the following interchangeability symbols is indicated beside the part.

Symbol	Interchangeability	Contents note
N	Old $\begin{matrix} \leftarrow \text{Yes} \\ \text{No} \rightarrow \end{matrix}$ New	New Part is interchangeable for Old Part but Old Part is not interchangeable for New Part.
Q	Old $\begin{matrix} \leftarrow \text{No} \\ \text{Yes} \rightarrow \end{matrix}$ New	New Part is not interchangeable for Old Part but Old Part is interchangeable for New Part.
R	Old $\begin{matrix} \leftarrow \text{Yes} \\ \text{Yes} \rightarrow \end{matrix}$ New	New/ Old Parts are both interchangeable.
S	Old $\begin{matrix} \leftarrow \text{No} \\ \text{No} \rightarrow \end{matrix}$ New	New/ Old Parts are both not interchangeable.
W		Part newly added.
Z		Part discontinued.
F		Not interchangeable by a single part but interchangeable together with related parts.
K		Changes only for used parts quantities.

④ Effective Machine No.

When a part changes, the effective Machine No. will be indicated in the (A)-(F) column.

Product Symbol	Product No.	Product Symbol	Product No.
C	Clutch No. Compressor No.	F	Machine No. (Agricultural Equip.)
D	Drive No.	M	Machine No.
E	Engine No.		

Note 1) A date may follow the symbol. (Ex.) 1996.01

Note 2) "XXXXX" and "ZZZZZ" are for parts that could not be predicted or for engine models that could not be identified.

Note 3) (A=E00185) is the E (Engine Serial Number) for the column (A) model (in this case 4JH-DT) after the parts design change.

⑤ Remarks

Figures or alphabets (symbols) are entered in the remarks column.

The comments (remarks) on parts that are indicated at the bottom of the illustration are the same symbols as those stated above.

Contents

0CW10-M80100

Fig. No. Fig. Name

3TNV80F-SSNS2

1. CYLINDER BLOCK
2. GEAR HOUSING
3. MOUNTING FLANGE & OIL SUMP
4. CYLINDER HEAD & BONNET
5. EXHAUST MANIFOLD & SILENCER
6. CAMSHAFT & DRIVING GEAR
7. CRANKSHAFT & PISTON
8. LUB.OIL SYSTEM
9. COOLING WATER SYSTEM
10. FUEL INJECTION PUMP
11. GOVERNOR
12. FUEL INJECTION VALVE
13. FUEL FILTER
14. STARTING MOTOR
15. GENERATOR
16. GASKET SET

Fig. No. Fig. Name

Fig.1. CYLINDER BLOCK

(A)=3TNV80F-SSNS2

(B)=

(C)=

(D)=

(E)=

(F)=

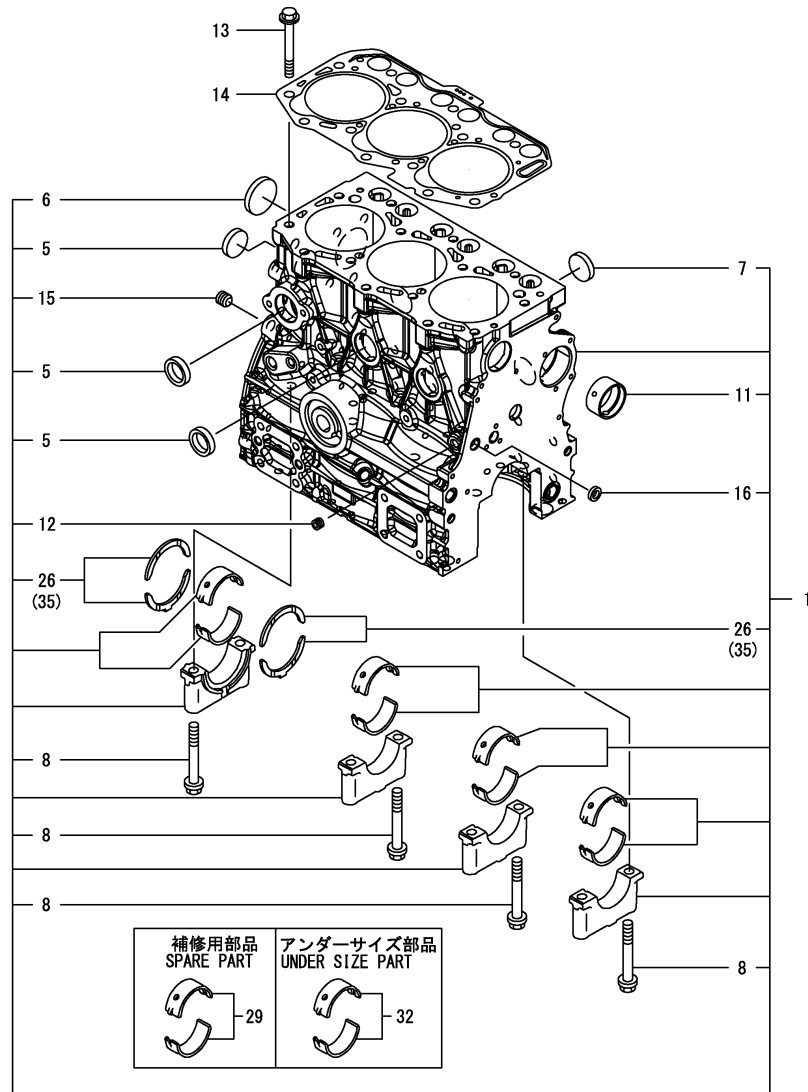

No.	Lev.	Parts No.	Description	Q'ty						I	R
				(A)	(B)	(C)	(D)	(E)	(F)		
1	1	119E00-01560	BLOCK ASSY, CYLINDER	1							
5	2	105311-01090	PLUG, 30	4							
6	2	119623-01250	PLUG, 45	1							
7	2	119285-01990	PLUG, 25	3							
8	2	119620-02020	BOLT, METAL CAP	8							
11	2	119717-02411	BUSH, CAMSHAFT	1							
12	2	124060-01050	PLUG, PT1/8	1							
13	2	119810-01200	BOLT, HEAD	14							
14	2	119E10-01330	GASKET SET, HEAD	1							
15	2	124160-01910	PLUG, PT1/4	1							
16	2	27241-120000	PLUG, 12	1							
26	2	119717-02930	BEARING, THRUST	2							
29	1	719717-02901	BEARING, MAIN	4							1
32	1	719717-02911	BEARING, 0.25 US	4							2
35	1	119810-02941	BEARING, THRUST 0.25	2							3

Remarks

- (1) Spare part.
- (2) Under-sized(U.S.=0.25)part.
- (3) Over-sized(O.S.=0.25)part.

Fig.2. GEAR HOUSING

(A)=3TNV80F-SSNS2

(B)=

(C)=

(D)=

(E)=

(F)=

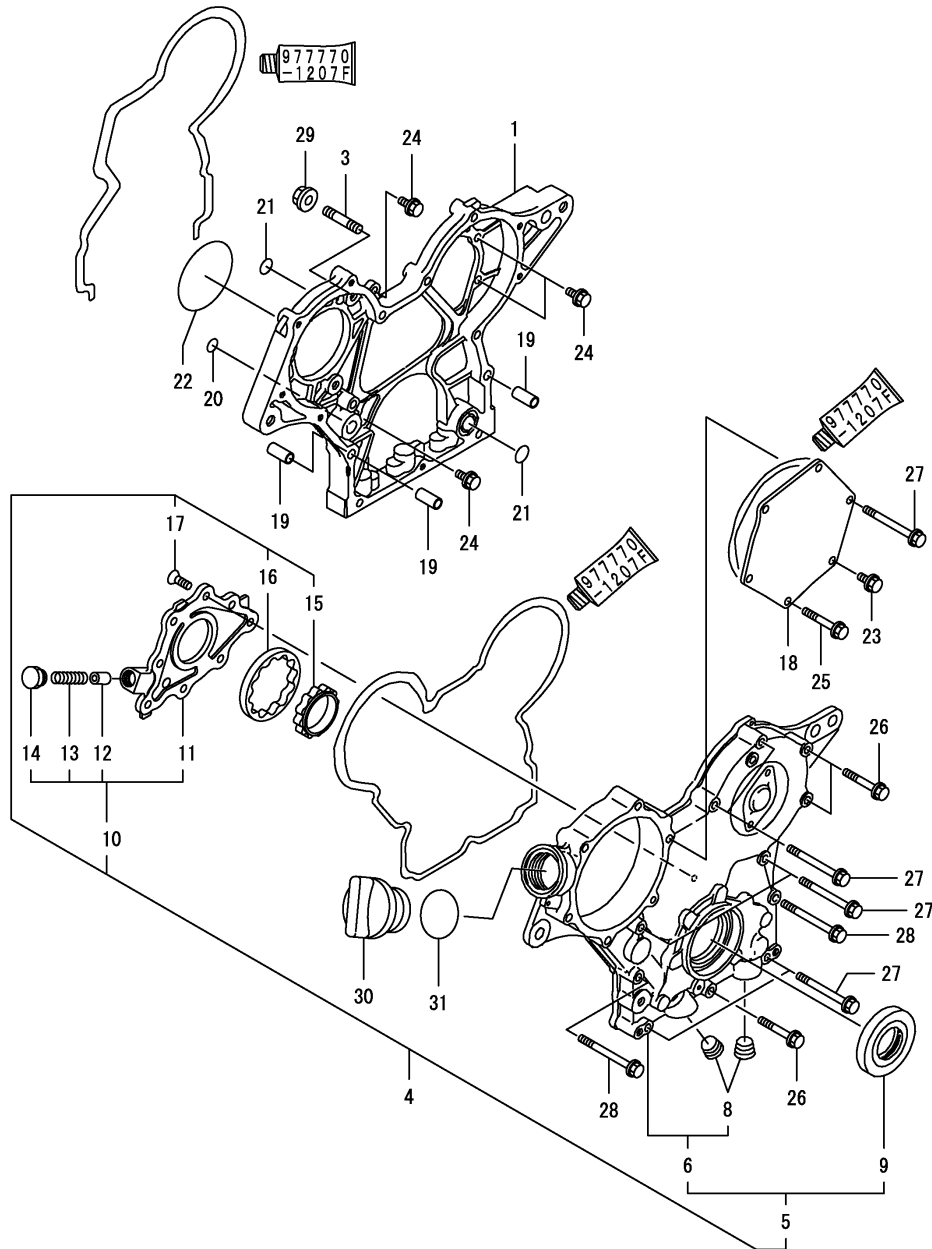

No.	Lev.	Parts No.	Description	Q'ty						I	R
				(A)	(B)	(C)	(D)	(E)	(F)		
1	1	119717-01501	CASE, GEAR	1							
3	1	119717-01570	STUD	3							
4	1	119734-01590	COVER ASSY, GEAR CASE	1							
5	2	719734-01500	COVER ASSY, GEAR CASE	1							
6	3	119717-01521	COVER, GEAR CASE	1							
8	4	23876-030000	PLUG, R03	2							
9	3	119717-01800	SEAL, OIL	1							
10	2	119717-32100	COVER ASSY	1							
11	3	119717-32080	COVER	1							
12	3	129900-32130	VALVE, RELIEF	1							
13	3	129001-32320	SPRING	1							
14	3	129001-32330	PLUG	1							
15	2	119717-32110	ROTOR, INNER	1							
16	2	119717-32120	ROTOR, OUTER	1							
17	2	119802-32130	SCREW, M6X16	8							
18	1	119717-01750	COVER	1							
19	1	119660-01911	PIPE, KNOCK	4							
20	1	119624-32040	O-RING, P12.0	1							
21	1	119717-32050	O-RING, P17.0	3							
22	1	121850-51960	O-RING	1							
23	1	26106-060122	BOLT, M6X 12 PLATED	1							
24	1	26106-060162	BOLT, M6X 16 PLATED	4							
25	1	26106-060402	BOLT, M6X 40 PLATED	4							
26	1	26106-060402	BOLT, M6X 40 PLATED	3							
27	1	26106-060602	BOLT, M6X 60 PLATED	7							
28	1	26106-060652	BOLT, M6X 65 PLATED	2							
29	1	26306-080002	NUT, M8	3							
30	1	124160-01751	COVER, FILLER	1							
31	1	24311-000320	O-RING, 1AP32.0	1							

Fig.3. MOUNTING FLANGE & OIL SUMP

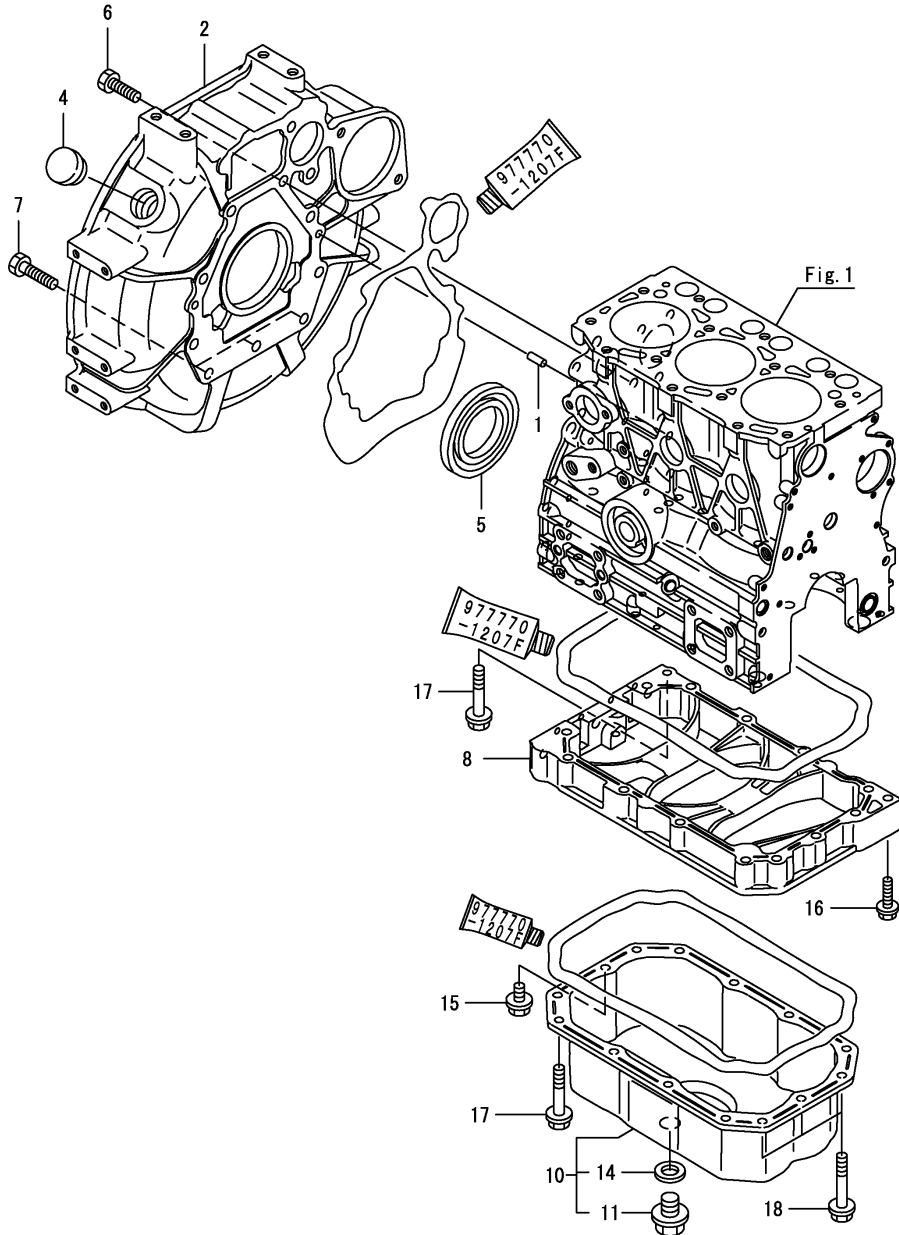

(A)=3TNV80F-SSNS2
(B)=
(C)=

(D)=
(E)=
(F)=

No.	Lev.	Parts No.	Description	Qty						I	R
				(A)	(B)	(C)	(D)	(E)	(F)		
1	1	129100-01580	PIN, 8X16	2							
2	1	119717-01601	HOUSING, FLYWHEEL	1							
4	1	119620-01750	CAP	1							
5	1	124085-02220	SEAL, OIL	1							
6	1	26206-100252	BOLT, M10X 25 PLATED	8							
7	1	26206-100302	BOLT, M10X 30 PLATED	3							
8	1	119717-01720	SPACER, OIL SUMP	1							
10	1	119740-01770	SUMP ASSY, OIL	1							
11	2	105425-01690	PLUG, 16	1							
14	2	22190-160002	WASHER, SEAL 16	1							
15	1	26106-080122	BOLT, M8X 12 PLATED	1							
16	1	26106-080302	BOLT, M8X 30 PLATED	1							
17	1	26106-080452	BOLT, M8X 45 PLATED	11							
18	1	26106-080502	BOLT, M8X 50 PLATED	3							

Fig.4. CYLINDER HEAD & BONNET

(A)=3TNV80F-SSNS2

(B)=

(C)=

(D)=

(E)=

(F)=

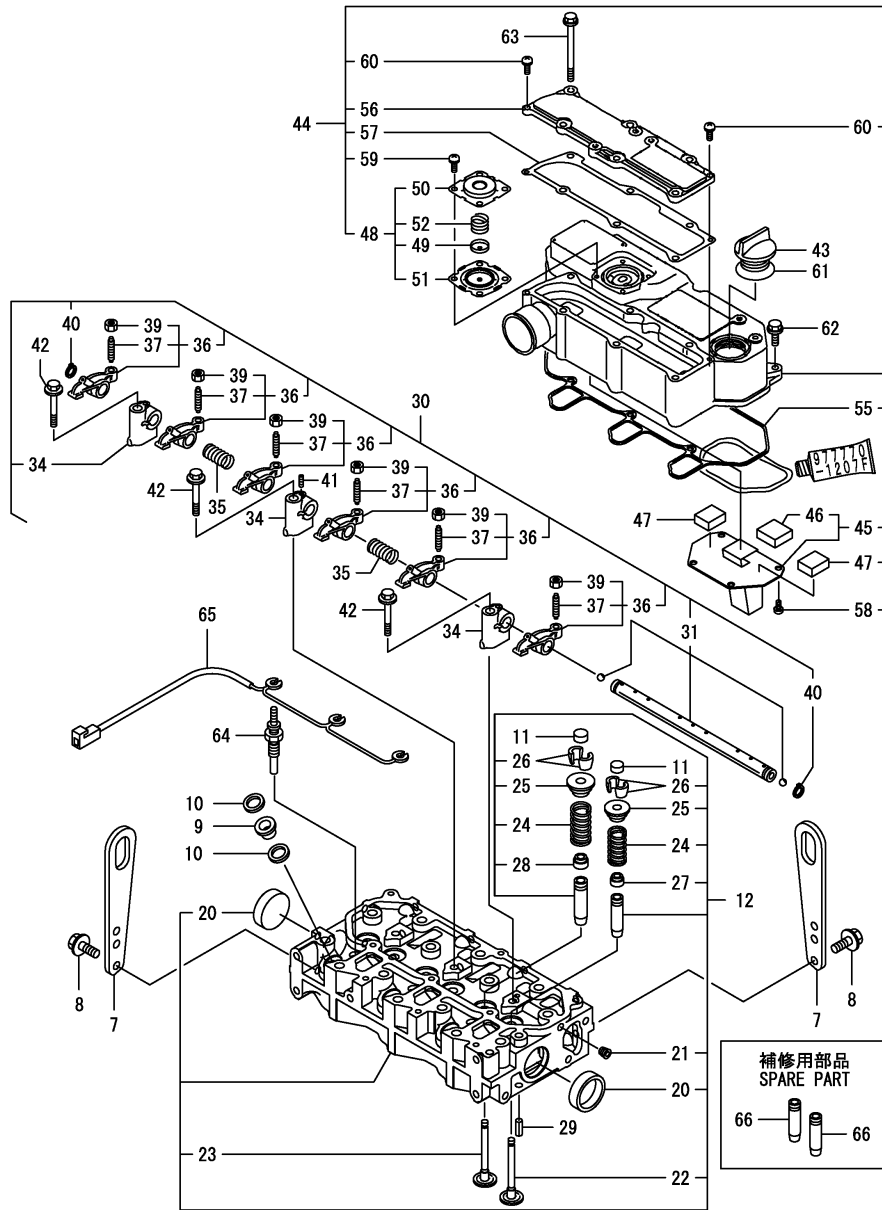

No.	Lev.	Parts No.	Description	Qty						I	R
				(A)	(B)	(C)	(D)	(E)	(F)		
7	1	129900-07900	LIFTER	2							
8	1	26106-080162	BOLT, M8X 16 PLATED	4							
9	1	129901-11450	PROTECTOR, NOZZLE	3							
10	1	119600-11460	GASKET, NOZZLE	6							
11	1	105010-11490	CAP, VALVE	6							
12	1	119E10-11740	HEAD ASSY, CYLINDER	1							
20	3	119285-11990	PLUG, 35	2							
21	3	23876-005000	PLUG, R005	1							
22	2	119E10-11100	VALVE, SUCTION	3							
23	2	119E10-11110	VALVE, EXHAUST	3							
24	2	119717-11131	SPRING, VALVE	6							
25	2	129508-11180	RETAINER, SPRING	6							
26	2	119717-11190	COTTER	12							
27	2	119717-11340	SEAL, VALVE STEM	3							
28	2	119717-11350	SEAL, VALVE STEM	3							
29	1	22351-060012	PIN, SPRING 6.0X12	2							
30	1	119717-11200	SUPPORT ASSY, ARM	1							
31	2	119717-11240	SHAFT ASSY, ROCKER	1							
34	2	119717-11260	SUPPORT, ROCKER ARM	3							
35	2	119620-11280	SPRING	2							
36	2	119717-11650	ARM, ROCKER	6							
37	3	129150-11230	SCREW, VALVE ADJUST	6							
39	3	129150-11750	NUT, M8	6							
40	2	22242-000120	RING, 12	2							
41	2	26979-050162	SCREW, M5X16	1							
42	1	26106-080402	BOLT, M8X 40 PLATED	3							
43	1	124160-01751	COVER, FILLER	1							
44	1	119717-11381	BONNET ASSY, HEAD	1							
45	2	119717-03031	PLATE	1							
46	3	119717-03070	BAFFLE, BREATHER	1							
47	2	119717-03070	BAFFLE, BREATHER	2							
48	2	119802-03100	DIAPHRAGM ASSY	1							
49	3	119802-03110	PLATE	1							
50	3	119802-03121	COVER, DIAPHRAGM	1							
51	3	119802-03131	DIAPHRAGM	1							
52	3	119802-03141	SPRING, DIAPHRAGM	1							
55	2	119718-11310	GASKET, BONNET	1							
56	2	119717-11320	COVER, BONNET	1							
57	2	119717-11331	GASKET	1							
58	2	22857-500100	SCREW, 5X10	4							
59	2	22857-500100	SCREW, 5X10	4							
60	2	22857-500160	SCREW, 5X16	2							
61	1	24311-000320	O-RING, 1AP32.0	1							
62	1	26106-060202	BOLT, M6X 20 PLATED	3							
63	1	26106-060752	BOLT, M6X 75 PLATED	6							
64	1	119717-77801	PLUG, GLOW	3							
65	1	119717-77820	CONNECTOR, GLOW PLUG	1							
66	1	119717-11800	GUIDE, VALVE	6							

Remarks
(1) Spare part.

Fig.5. EXHAUST MANIFOLD & SILENCER

(A)=3TNV80F-SSNS2
(B)=
(C)=

(D)=
(E)=
(F)=

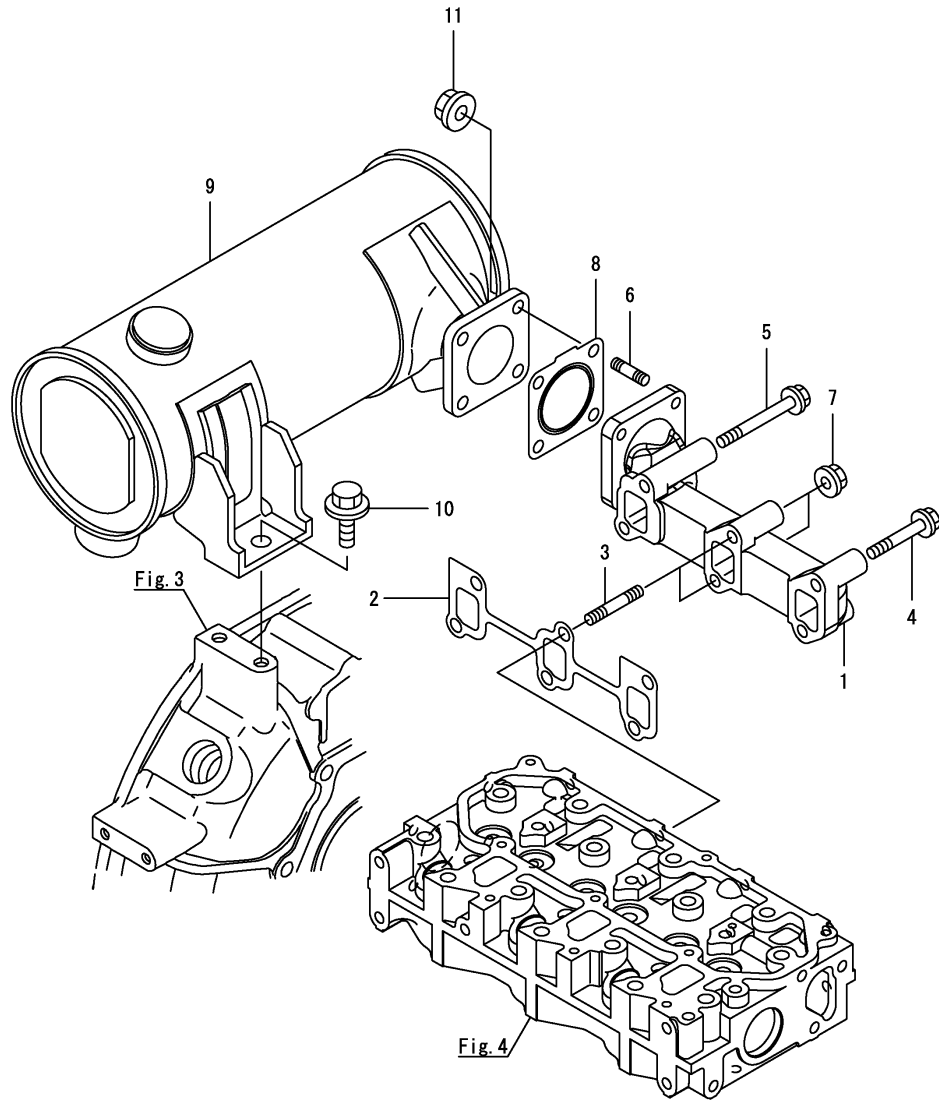

No.	Lev.	Parts No.	Description	Q'ty						I	R
				(A)	(B)	(C)	(D)	(E)	(F)		
1	1	119740-13100	MANIFOLD, EXHAUST	1							
2	1	119717-13110	GASKET	1							
3	1	119717-13600	STUD, M8X50	2							
4	1	119802-13620	BOLT, M8X50	2							
5	1	123900-13620	BOLT, M8X70	2							
6	1	119131-18320	STUD, M8X22	4							
7	1	26306-080002	NUT, M8	2							
8	1	119515-13200	GASKET, SILENCER	1							
9	1	119740-13500	SILENCER	1							
10	1	26106-100182	BOLT, M10X 18 PLATED	1							
11	1	26306-080002	NUT, M8	4							

Fig.6. CAMSHAFT & DRIVING GEAR

(A)=3TNV80F-SSNS2
(B)=
(C)=

(D)=
(E)=
(F)=

No.	Lev.	Parts No.	Description	Q'ty						I	R
				(A)	(B)	(C)	(D)	(E)	(F)		
1	1	119620-14200	TAPPET	6							
2	1	119717-14400	ROD, PUSH	6							
3	1	119717-14581	CAMSHAFT ASSY	1							
9	1	26106-060122	BOLT, M6X 12 PLATED	2							
10	1	119717-25050	SHAFT, IDLE	1							
11	1	119717-25101	GEAR ASSY, IDLE	1							
14	1	26106-060352	BOLT, M6X 35 PLATED	3							
15	1	129150-25301	BOLT	4							
16	1	119717-25930	GEAR, PUMP	1							
17	1	119717-25911	BUSH, IDLE GEAR	1							1
18	1	119717-51150	FLANGE	1							

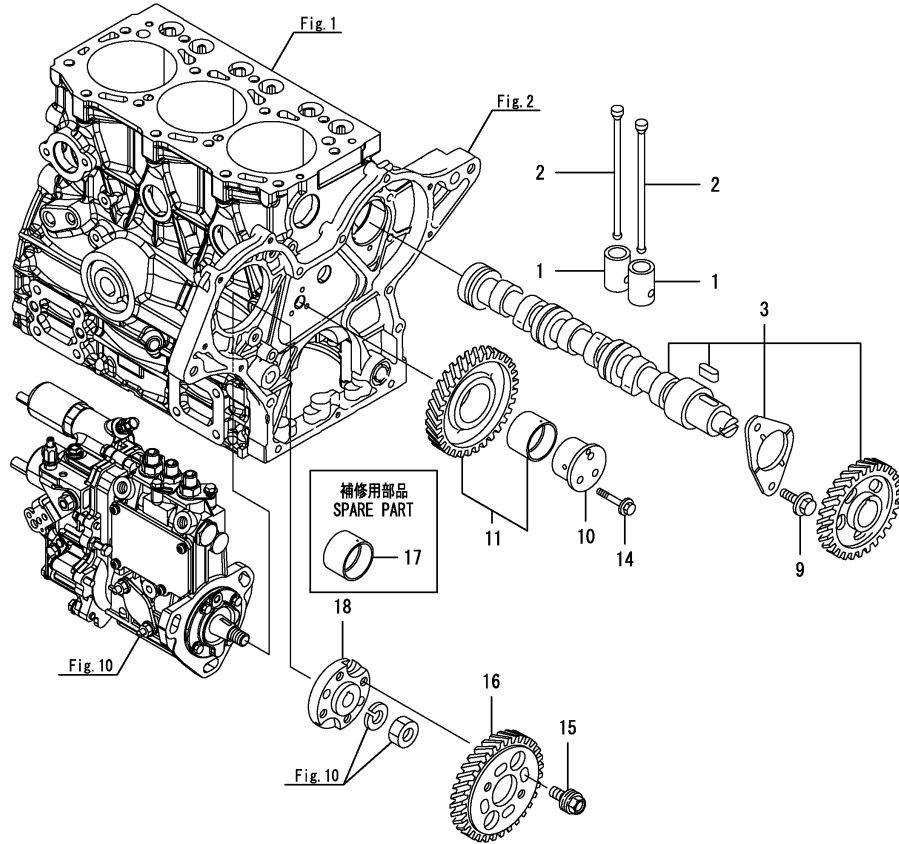

Remarks
(1)Spare part.

Fig.7. CRANKSHAFT & PISTON

(A)=3TNV80F-SSNS2

(B)=

(C)=

(D)=

(E)=

(F)=

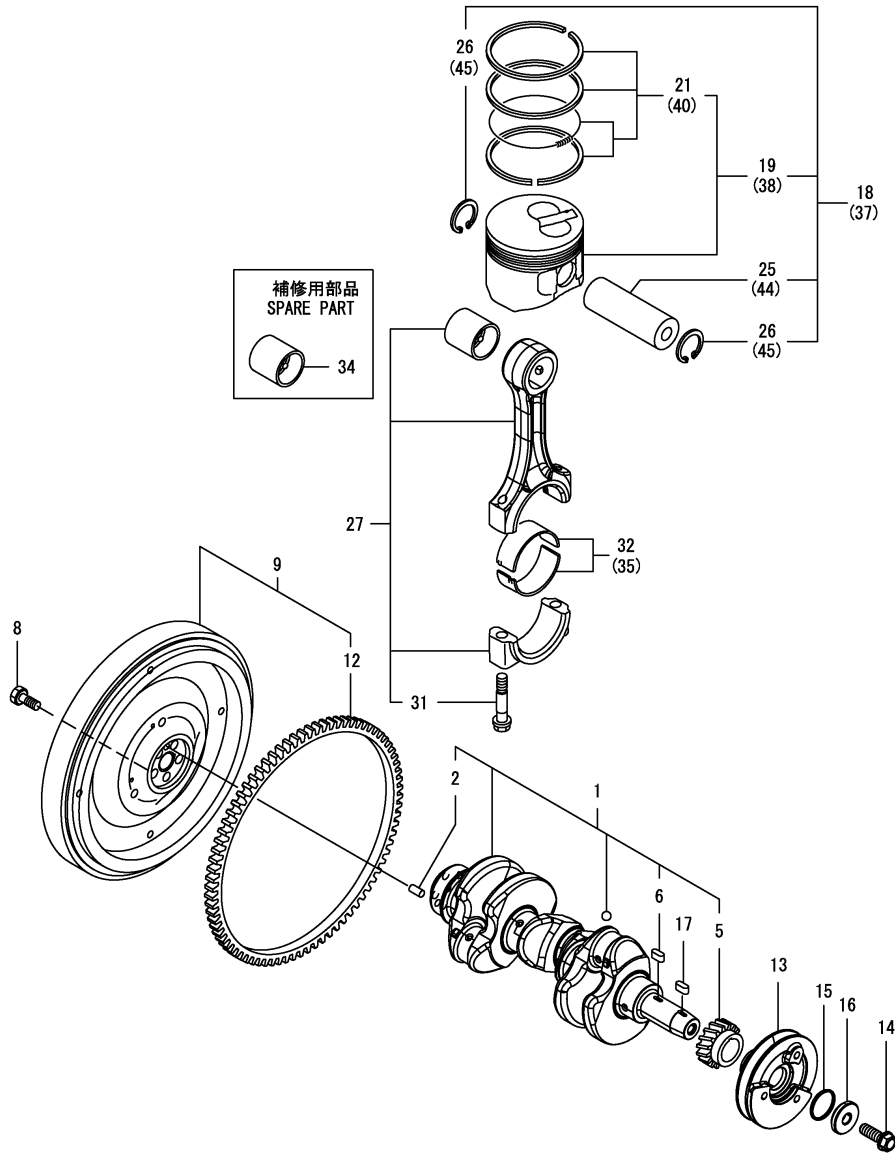

No.	Lev.	Parts No.	Description	Q'ty						I	R
				(A)	(B)	(C)	(D)	(E)	(F)		
1	1	119E10-21700	CRANKSHAFT ASSY	1							
2	2	129100-01580	PIN, 8X16	1							
5	2	119717-21200	GEAR, CRANKSHAFT	1							
6	2	22512-040120	KEY, 4X 12	1							
8	1	119620-21500	BOLT, FLYWHEEL	5							
9	1	119E40-21590	FLYWHEEL ASSY	1							
12	2	119865-21600	GEAR, RING	1							
13	1	119C10-21650	V-PULLEY, CRANKSHAFT	1							
14	1	119621-21681	BOLT, FLANGE 12X1.25	1							
15	1	119C10-21930	PACKING, WASHER	1							
16	1	119C10-21940	WASHER, V-PULLEY	1							
17	1	22512-040120	KEY, 4X 12	1							
18	1	119E18-22900	PISTON ASSY	3							
19	2	119E10-22080	PISTON ASSY	3							
21	3	119E10-22500	RING ASSY	3							
25	1	119E10-22300	PIN, PISTON	3							
26	1	22252-000220	RING, 22	6							
27	1	119E10-23000	ROD ASSY, CONNECTING	3							
31	2	119717-23200	BOLT, CONNECTING ROD	6							
32	1	119717-23601	BEARING, CRANK PIN	3							
34	1	119717-23910	BEARING, PISTON PIN	3							1
35	1	119717-23611	METAL ASSY, 0.25	3							2
37	1	119E18-22910	PISTON ASSY, 0.25 OS	3							3
38	2	119E10-22900	PISTON ASSY, 0.25 OS	3							3
40	3	119E10-22550	RING ASSY, 0.25	3							3
44	2	119E10-22300	PIN, PISTON	3							3
45	2	22252-000220	RING, 22	6							3

Remarks

- (1) Spare part.
- (2) Under-sized(U.S.=0.25)part.
- (3) Over-sized(O.S.=0.25)part.

Fig.8. LUB.OIL SYSTEM

(A)=3TNV80F-SSNS2
(B)=
(C)=

(D)=
(E)=
(F)=

No.	Lev.	Parts No.	Description	Q'ty						I	R
				(A)	(B)	(C)	(D)	(E)	(F)		
1	1	119717-34801	DIPSTICK, OIL	1							
2	1	121520-34810	GUIDE, DIPSTICK	1							
3	1	119717-35140	BOLT	1							
5	1	119717-32060	O-RING, P15.0	1							
6	1	119717-35080	PIPE ASSY, OIL INLET	1							
10	1	26106-060102	BOLT, M6X 10 PLATED	2							
11	1	121252-39450	SWITCH, 0.5KG	1							
12	1	119717-39210	PIPE, OIL	1							
13	1	129005-59830	BOLT ASSY, JOINT M8	2							
14	2	22190-080002	WASHER, SEAL 8	2							
15	2	23857-030000	BOLT, JOINT 3	2							
16	1	22190-080002	WASHER, SEAL 8	2							
17	1	119305-35151	FILTER ASSY, D68XL65	1							1

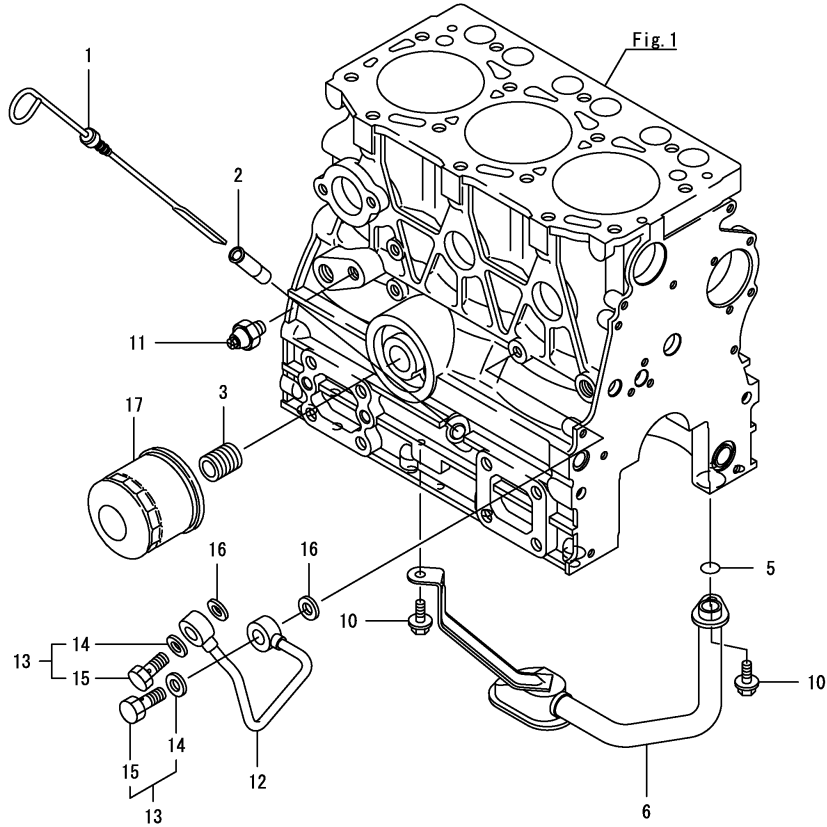

Remarks
(1)Spare part.

Fig.9. COOLING WATER SYSTEM

(A)=3TNV80F-SSNS2

(B)=

(C)=

(D)=

(E)=

(F)=

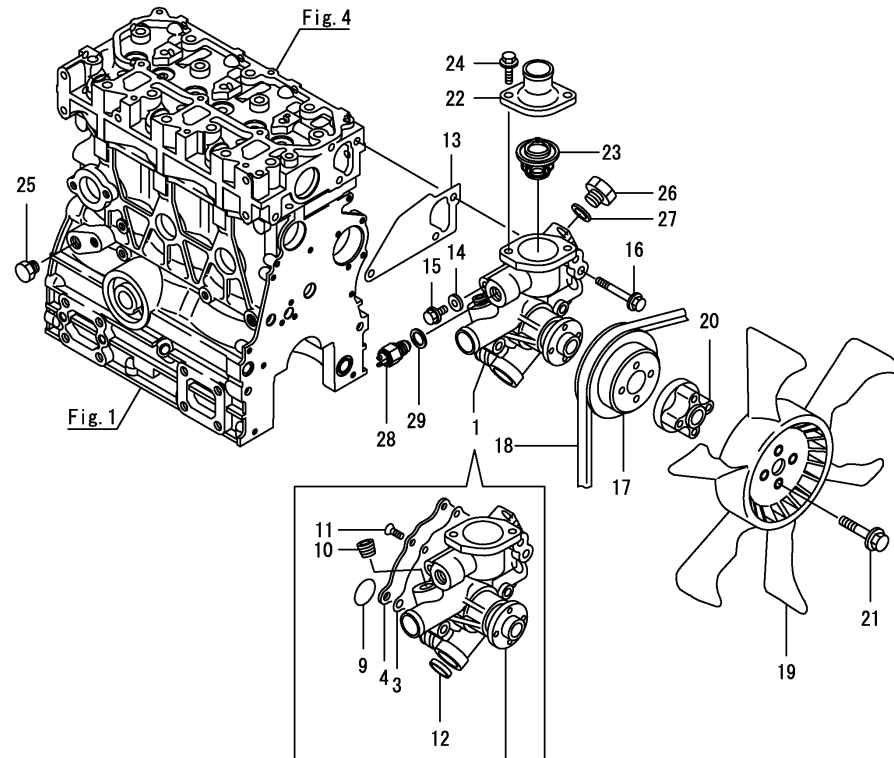

No.	Lev.	Parts No.	Description	Q'ty						I	R
				(A)	(B)	(C)	(D)	(E)	(F)		
1	1	119E10-42000	PUMP ASSY, WATER	1							
3	2	119717-42031	GASKET	1							
4	2	119717-42041	COVER	1							
9	2	119C10-42320	O-RING, 2028	1							
10	2	129916-49740	PLUG, R03	1							
11	2	26577-060122	SCREW, M6X12	4							
12	2	27241-250000	PLUG, 25	1							
13	1	119717-42020	GASKET, WATER PUMP	1							
14	1	23414-080000	GASKET, 8X1.0	1							
15	1	26106-080122	BOLT, M8X 12 PLATED	1							
16	1	26106-080502	BOLT, M8X 50 PLATED	3							
17	1	119515-42350	V-PULLEY, D=110	1							
18	1	25132-003600	V-BELT, A36	1							
19	1	129030-44740	FAN, COOLING D360XUG	1							
20	1	129457-44760	SPACER, FAN	1							
21	1	26106-060452	BOLT, M6X 45 PLATED	4							
22	1	129350-49530-1	COVER, THERMOSTAT	1							
23	1	119717-49800	THERMOSTAT, 71	1							
24	1	26106-080202	BOLT, M8X 20 PLATED	2							
25	1	171056-49120	PLUG, DRAIN	1							
26	1	121450-42450	PLUG, M16	1							
27	1	124465-44950	GASKET, 16	1							
28	1	124250-49351	SENSOR	1							
29	1	129150-49360	GASKET	1							
30	1	171064-44510	TANK ASSY, SUB	1							
32	2	121450-44531	CAP	1							
33	2	124450-44560	RETAINER	1							
34	2	121470-44581	GASKET	1							
35	2	23065-070225	HOSE 7X 225	1							
36	1	124450-44550	BAND	1							
37	1	121256-44600	BRACKET, SUB TANK	1							
38	1	121250-44901	SWITCH, 110	1							
39	1	23010-038000	CLAMP, 38	4							

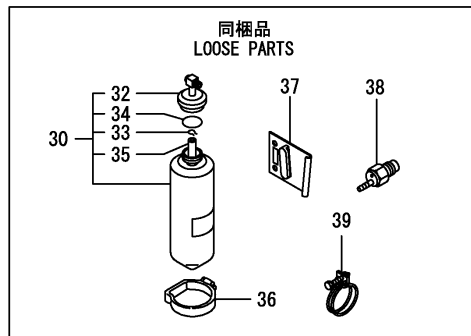
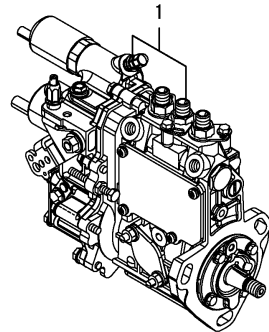
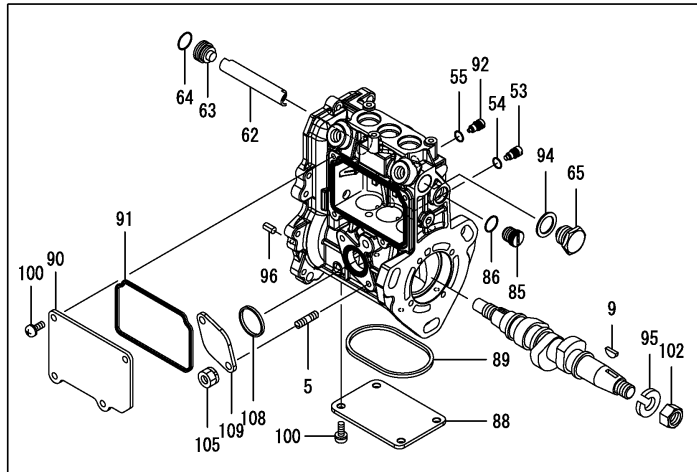

Fig.10. FUEL INJECTION PUMP

(A)=3TNV80F-SSNS2
(B)=
(C)=

(D)=
(E)=
(F)=



No.	Lev.	Parts No.	Description	Q'ty						I	R
				(A)	(B)	(C)	(D)	(E)	(F)		
1	1	719E40-51300	FIE ASSY	1							1
5	2	129155-51020	STUD	2							
9	2	122710-51090	KEY	1							
53	2	158600-51270	STOPPER, TAPPET	3							
54	2	129155-51280	O-RING, S6	3							
55	2	129155-51280	O-RING, S6	1							
62	2	129155-51400	DEFLECTOR	1							
63	2	158600-51410	PLUG, DEFLECTOR	1							
64	2	119717-51420	O-RING	1							
65	2	158600-51420	PLUG, DEFLECTOR	1							
85	2	158600-51570	PLUG	1							
86	2	129155-51580	O-RING	1							
88	2	129155-51701	COVER	1							
89	2	119717-51711	GASKET	1							
90	2	119717-51750	COVER	1							
91	2	119717-51761	GASKET	1							
92	2	158600-51790	STOOPER, RACK	1							
94	2	22190-160002	WASHER, SEAL 16	1							
95	2	22217-120000	WASHER, SPRING 12	1							
96	2	22351-050010	PIN, SPRING 5.0X10	2							
100	2	26022-050122	SCREW, M5X12	8							
102	2	26716-120002	NUT, M12	1							
105	2	119717-51860	NUT, M6	2							
108	2	129155-52051	GASKET	1							
109	2	129100-52200	COVER	1							

Remarks

(1)Governor(Fig.11)is incorporated in this Fuel Injection Pump (Ref.1).

Fig.11. GOVERNOR

(A)=3TNV80F-SSNS2
(B)=
(C)=

(D)=
(E)=
(F)=

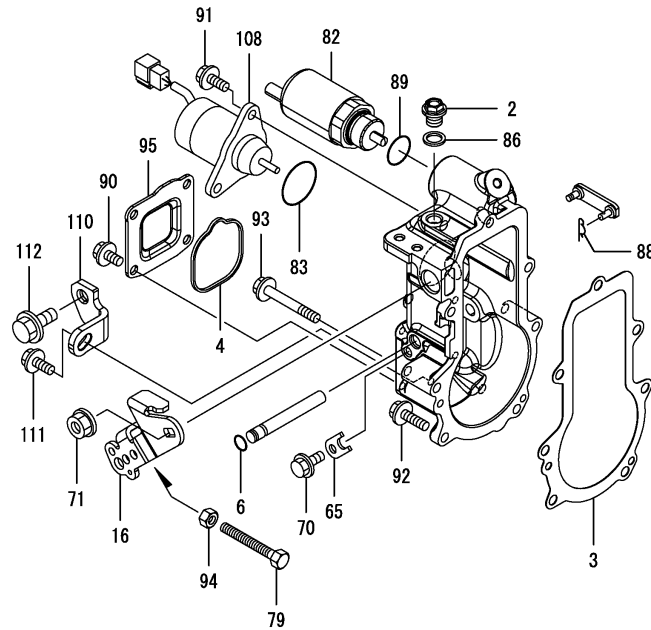

No.	Lev.	Parts No.	Description	Q'ty						I	R
				(A)	(B)	(C)	(D)	(E)	(F)		
2	2	119717-51930	PLUG,M10	1							
3	2	119717-61050	GASKET	1							
4	2	119717-61070	GASKET	1							
6	2	129155-51280	O-RING, S6	1							
16	2	119515-61440	LEVER, CONTROL	1							
65	2	119660-61901	RETAINER, SHAFT	1							
70	2	26106-060102	BOLT, M6X 10 PLATED	1							
71	2	26366-080002	NUT, M8	1							
79	2	129155-61460	BOLT, IDLE	1							
82	2	119C00-61900	SOLENOID, POWER CONT	1							
83	2	158552-61900	O-RING	1							
86	2	22190-100002	WASHER, SEAL 10	1							
88	2	22372-040000	PIN, SNAP 4	1							
89	2	24316-000200	O-RING, 4DP20.0	1							
90	2	26106-060102	BOLT, M6X 10 PLATED	4							
91	2	26106-060142	BOLT, M6X 14 PLATED	2							
92	2	26106-060202	BOLT, M6X 20 PLATED	4							
93	2	26106-060452	BOLT, M6X 45 PLATED	3							
94	2	26756-060002	NUT, LOCK M6	1							
95	1	119717-61060	COVER, GOVERNOR CASE	1							
108	1	119233-77932	SOLENOID, STOP	1							
110	1	119C10-51250	SUPPORT	1							
111	1	26106-060142	BOLT, M6X 14 PLATED	1							
112	1	26106-080142	BOLT, M8X 14 PLATED	1							

Remarks

*This figure(Governor)is incorporated in the Fuel Injection Pump (Fig.10).

Fig.12. FUEL INJECTION VALVE

(A)=3TNV80F-SSNS2
(B)=
(C)=

(D)=
(E)=
(F)=

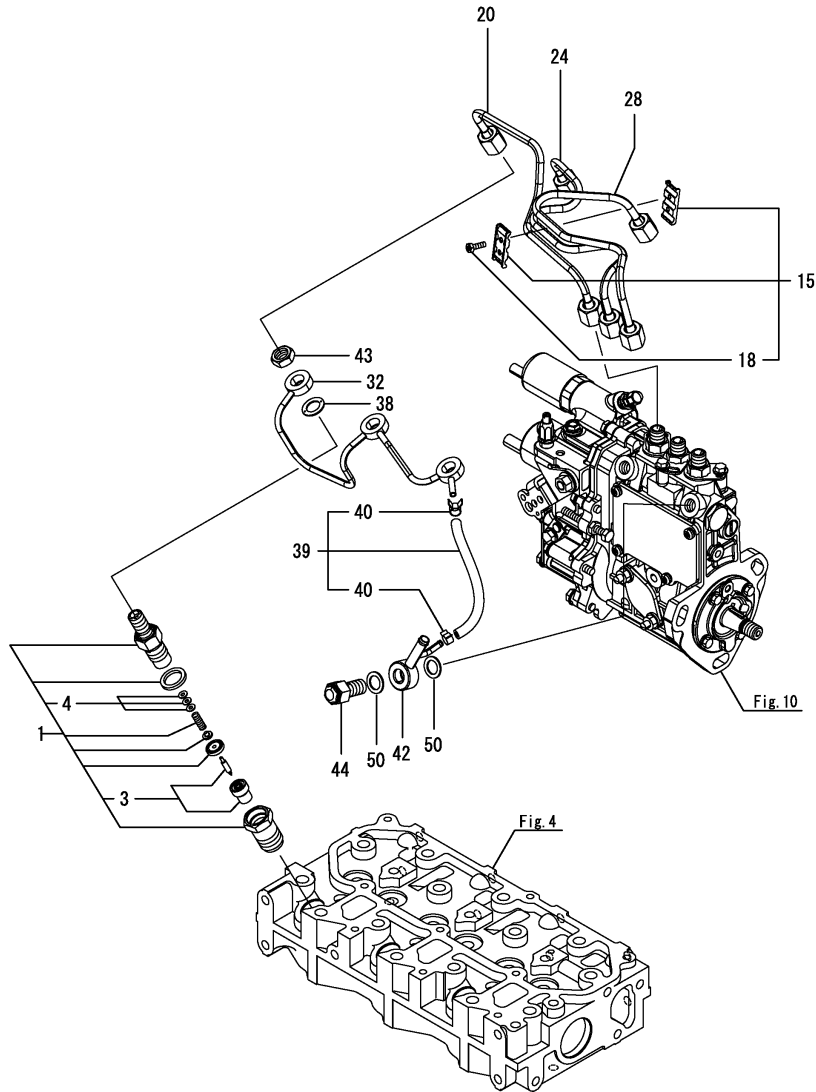

No.	Lev.	Parts No.	Description	Q'ty						I	R
				(A)	(B)	(C)	(D)	(E)	(F)		
1	1	119C10-53000	NOZZLE ASSY, F.I.	3							
3	2	119C10-53010	NOZZLE ASSY	3							
4	2	129901-53800	SHIM SET, ADJUSTING	3							1
15	1	129150-59120	RETAINER, PIPE	1							
18	2	129150-59131	BOLT, M4X14	2							
20	1	119E10-59810	PIPE ASSY, INJ. NO1	1							
24	1	119E10-59820	PIPE ASSY, INJ. NO2	1							
28	1	119E10-59830	PIPE ASSY, INJ. NO3	1							
32	1	119717-59510	PIPE ASSY, RETURN	1							
38	1	129901-59560	GASKET	3							
39	1	119540-59570	PIPE ASSY, RETURN	1							
40	2	124066-59100	CLIP, HOSE 8	2							
42	1	119840-59570	JOINT	1							
43	1	119620-59700	NUT, NOZZLE	3							
44	1	119813-59950	VALVE ASSY, CHECK	1							
50	1	22190-120002	WASHER, SEAL 12	2							

Remarks

(1) Spare parts.

Fig.13. FUEL FILTER

(A)=3TNV80F-SSNS2
(B)=
(C)=

(D)=
(E)=
(F)=

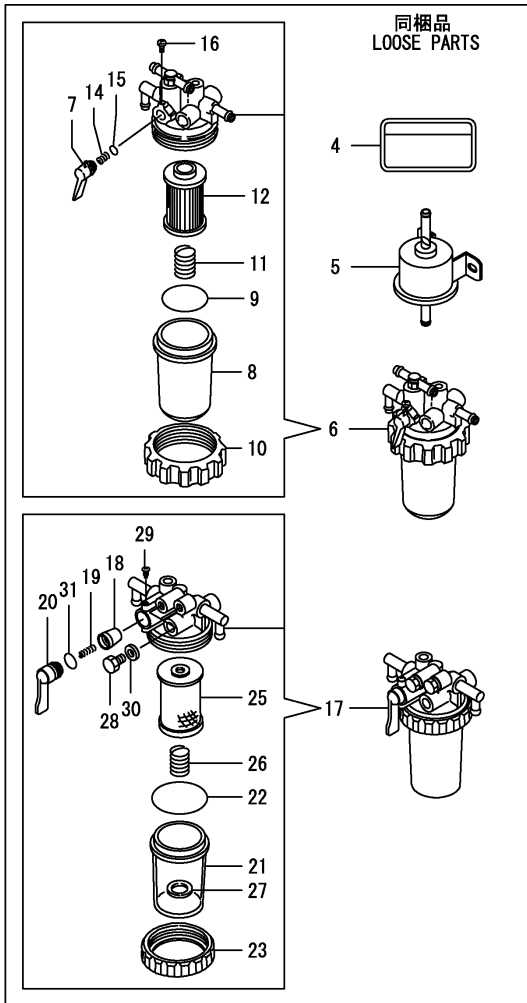
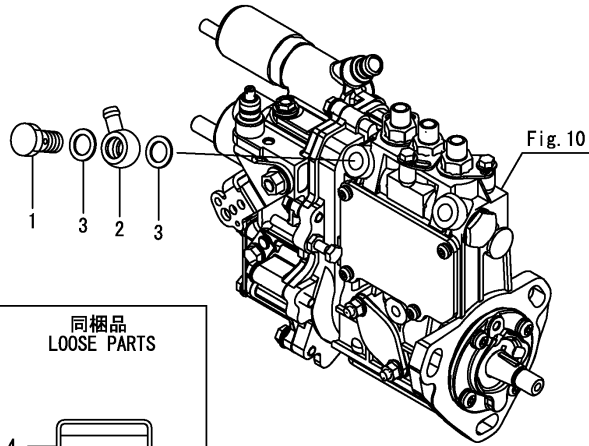

No.	Lev.	Parts No.	Description	Qty						I	R
				(A)	(B)	(C)	(D)	(E)	(F)		
1	1	103854-39140	BOLT, PIPE JOINT	1							
2	1	101304-59020	JOINT, PIPE 12	1							
3	1	22190-120002	WASHER, SEAL 12	2							
4	1	114110-07761	LABEL, FUEL OIL CAUT	1							
5	1	119225-52102	PUMP ASSY, FUEL FEED	1							
6	1	119740-55600	FILTER ASSY, FUEL	1							
7	2	119810-55340	LEVER	1							
8	2	121254-55510	COVER	1							
9	2	102103-55520	O-RING	1							
10	2	110250-55610	RING, RETAINING	1							
11	2	121250-55620	SPRING	1							
12	2	119810-55650	ELEMENT	1							
14	2	104200-55330	SPRING, VALVE	1							
15	2	24311-240100	O-RING, 1AP10A	1							
16	2	104200-55750	SCREW, M4	1							
17	1	121850-55800	SEPARATOR ASSY,WATER	1							
18	2	104200-55321	VALVE, TAPER	1							
19	2	104200-55330	SPRING, VALVE	1							
20	2	104200-55341	HANDLE	1							
21	2	121254-55510	COVER	1							
22	2	102103-55520	O-RING	1							
23	2	110250-55610	RING, RETAINING	1							
25	2	121850-55710	SCREEN	1							
26	2	121257-55720	SPRING	1							
27	2	121257-55731	FLOAT	1							
28	2	101720-55750	PLUG, 6	2							
29	2	104200-55750	SCREW, M4	1							
30	2	23418-060000	GASKET, 6X1.0	2							
31	2	24311-240100	O-RING, 1AP10A	1							

Fig.14. STARTING MOTOR

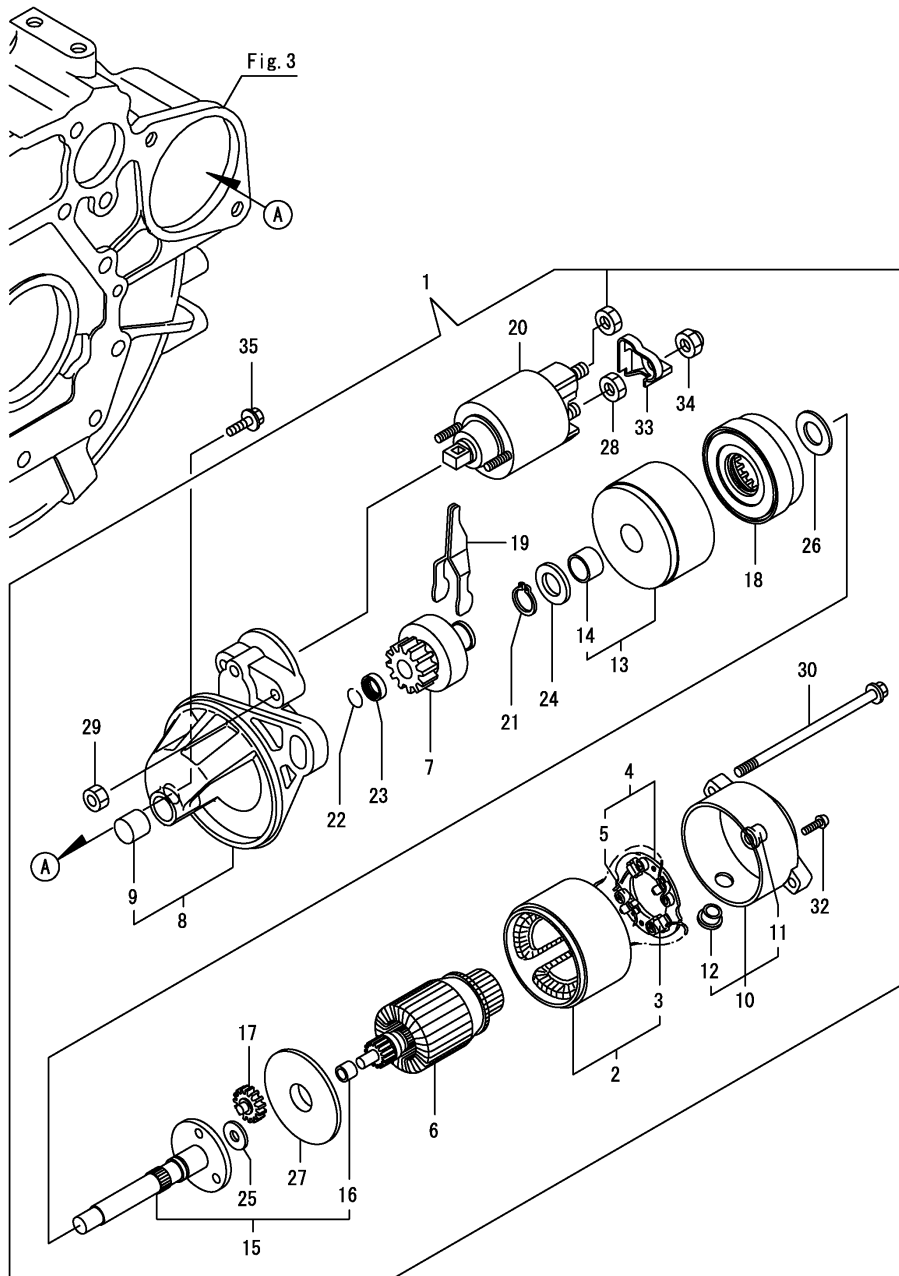

(A)=3TNV80F-SSNS2

(B)=

(C)=

(D)=

(E)=

(F)=

No.	Lev.	Parts No.	Description	Q'ty						I	R
				(A)	(B)	(C)	(D)	(E)	(F)		
1	1	119717-77010	STARTER, P1.1	1							
2	2	X0281007750	YOKE ASSY	1							
3	3	X0280996180	STARTER KIT	2							
4	2	X0285105190	HOLDER ASSY	1							
5	3	X0285205030	SPRING	4							
6	2	X0282005991	ARMATURE ASSY	1							
7	2	X0283006960	CLUTCH ASSY	1							
8	2	X4284001590	HOUSING ASSY	1							
9	3	X9491050100	BEARING, NEEDLE	1							
10	2	X0285007030	FRAME ASSY	1							
11	3	X9491040990	BEARING	1							
12	3	X0280626010	COVER	1							
13	2	X0284105040	BEARING ASSY	1							
14	3	X9491034330	BEARING	1							
15	2	X0286105010	SHAFT ASSY	1							
16	3	X9491034320	BEARING	1							
17	2	X0286305010	GEAR	3							
18	2	X0286355010	GEAR	1							
19	2	X0287405140	LEVER	1							
20	2	X0534007800	SWITCH ASSY	1							
21	2	X9055715000	RING	1							
22	2	X9490721360	RING	1							
23	2	X0280210331	NUT	1							
24	2	X9490138110	WASHER	1							
25	2	X9490138090	WASHER	1							
26	2	X9490138100	WASHER	1							
27	2	X0284525010	PLATE	1							
28	2	X9490562360	NUT	1							
29	2	X9490560750	NUT	2							
30	2	X9490423420	BOLT, THROUGH	2							
32	2	X9490065670	SCREW, M4X6	2							
33	2	X0280335350	COVER, TERMINAL	1							
34	2	X1289510130	NUT	1							
35	1	26106-100252	BOLT, M10X 25 PLATED	2							

Fig.15. GENERATOR

(A)=3TNV80F-SSNS2
(B)=
(C)=

(D)=
(E)=
(F)=

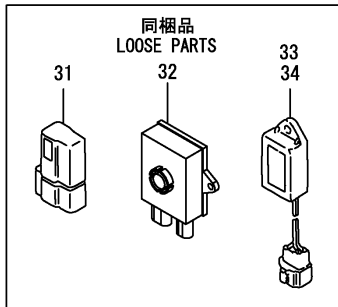
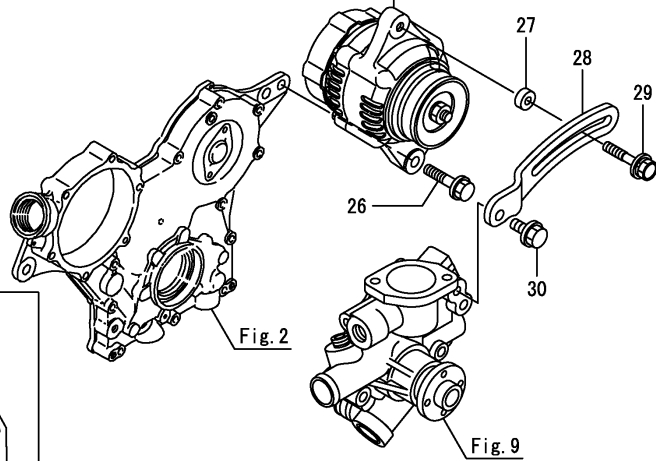
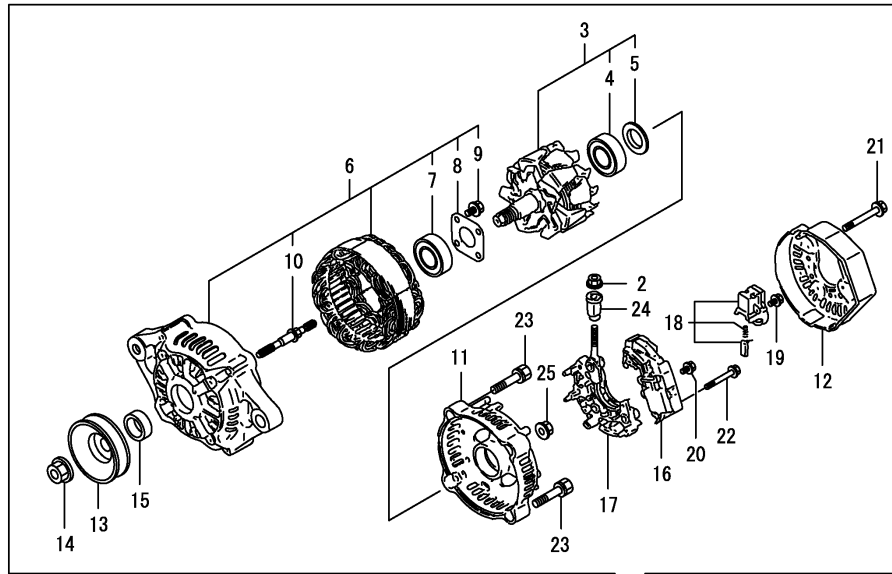

No.	Lev.	Parts No.	Description	Q'ty						I	R
				(A)	(B)	(C)	(D)	(E)	(F)		
1	1	119626-77210	ALTERNATOR, 12V-55A	1							
2	2	X9490561001	NUT	1							
3	2	129052-77380	ROTOR ASSY	1							
4	3	123501-79240	BEARING, BALL	1							
5	3	119620-79250	COVER	1							
6	2	129052-77422	FRAME ASSY	1							
7	3	119620-79200	BEARING, BALL	1							
8	3	119620-79210	PLATE, RETAINER	1							
9	3	119620-79220	SCREW	4							
10	3	119620-79230	STUD	2							
11	2	128401-77440	FRAME	1							
12	2	119626-77450	COVER	1							
13	2	119620-77461	PULLEY	1							
14	2	119620-77471	NUT	1							
15	2	119620-77490	COLLAR	1							
16	2	129423-77710	REGULATOR ASSY	1							
17	2	129052-79260	HOLDER	1							
18	2	129052-79270	HOLDER, BRUSH	1							
19	2	119620-79290	SCREW	6							
20	2	119620-79300	SCREW	1							
21	2	119620-79310	BOLT	3							
22	2	119620-79320	SCREW	2							
23	2	119620-79330	BOLT	2							
24	2	119620-79340	BUSH, INSULATION	1							
25	2	119620-79350	NUT	2							
26	1	26106-100452	BOLT, M10X 45 PLATED	1							
27	1	119940-77270	SPACER, GENERATOR	1							
28	1	119717-77340	ADJUSTER	1							
29	1	129972-77341	BOLT, ADJUSTER L=50	1							
30	1	26106-080202	BOLT, M8X 20 PLATED	1							
31	1	119643-66900	DIODE	1							
32	1	119C10-77600	DRIVER	1							
33	1	129155-77925	TIMER	1							
34	1	129211-77920	TIMER	1							

Fig.16. GASKET SET

(A)=3TNV80F-SSNS2

(B)=

(C)=

(D)=

(E)=

(F)=

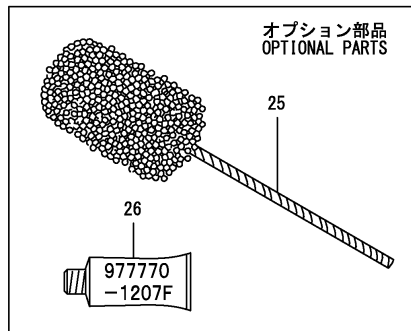
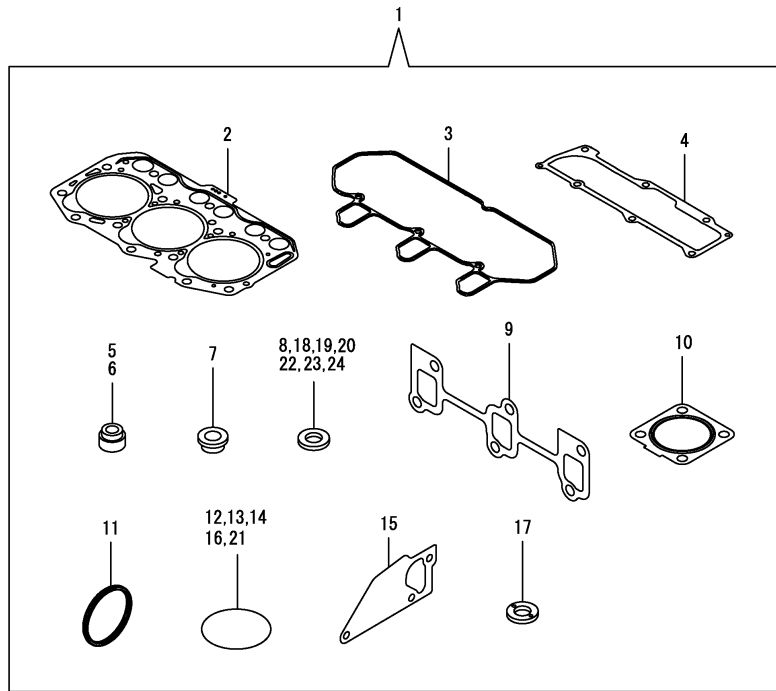

No.	Lev.	Parts No.	Description	Q'ty						I	R
				(A)	(B)	(C)	(D)	(E)	(F)		
1	1	119E40-92010	GASKET KIT	1							
2	2	119E10-01330	GASKET SET, HEAD	1							
3	2	119718-11310	GASKET, BONNET	1							
4	2	119717-11331	GASKET	1							
5	2	119717-11340	SEAL, VALVE STEM	3							
6	2	119717-11350	SEAL, VALVE STEM	3							
7	2	129901-11450	PROTECTOR, NOZZLE	3							
8	2	119600-11460	GASKET, NOZZLE	6							
9	2	119717-13110	GASKET	1							
10	2	119515-13200	GASKET, SILENCER	1							
11	2	119C10-21930	PACKING, WASHER	1							
12	2	119624-32040	O-RING, P12.0	1							
13	2	119717-32050	O-RING, P17.0	3							
14	2	119717-32060	O-RING, P15.0	1							
15	2	119717-42020	GASKET, WATER PUMP	1							
16	2	121850-51960	O-RING	1							
17	2	129901-59560	GASKET	3							
18	2	22190-080002	WASHER, SEAL 8	4							
19	2	22190-120002	WASHER, SEAL 12	4							
20	2	23414-080000	GASKET, 8X1.0	1							
21	2	24311-000320	O-RING, 1AP32.0	2							
22	2	22190-160002	WASHER, SEAL 16	1							
23	2	124465-44950	GASKET, 16	1							
24	2	129150-49360	GASKET	1							
25	1	129400-92420	HONE	1							1
26	1	977770-1207F	GASKET.LIQUID	1							1

Remarks

(1)Optional parts.

*Parts number will be informed later.

Parts No. Index

Parts No.	Fig. No.	Ref. No.
101304-59020	13	2
101720-55750	13	28
102103-55520	13	9
		22
103854-39140	13	1
104200-55321	13	18
104200-55330	13	14
		19
104200-55341	13	20
104200-55750	13	16
		29
105010-11490	4	11
105311-01090	1	5
105425-01690	3	11
110250-55610	13	10
		23
114110-07761	13	4
119131-18320	5	6
119225-52102	13	5
119233-77932	11	108
119285-01990	1	7
119285-11990	4	20
119305-35151	8	17
119515-13200	5	8
	16	10
119515-42350	9	17
119515-61440	11	16
119540-59570	12	39
119600-11460	4	10
	16	8
119620-01750	3	4
119620-02020	1	8
119620-11280	4	35
119620-14200	6	1
119620-21500	7	8
119620-59700	12	43
119620-77461	15	13
119620-77471	15	14
119620-77490	15	15
119620-79200	15	7
119620-79210	15	8
119620-79220	15	9
119620-79230	15	10
119620-79250	15	5
119620-79290	15	19
119620-79300	15	20
119620-79310	15	21
119620-79320	15	22
119620-79330	15	23
119620-79340	15	24

Parts No.	Fig. No.	Ref. No.
119620-79350	15	25
119621-21681	7	14
119623-01250	1	6
119624-32040	2	20
	16	12
119626-77210	15	1
119626-77450	15	12
119643-66900	15	31
119660-01911	2	19
119660-61901	11	65
119717-01501	2	1
119717-01521	2	6
119717-01570	2	3
119717-01601	3	2
119717-01720	3	8
119717-01750	2	18
119717-01800	2	9
119717-02411	1	11
119717-02930	1	26
119717-03031	4	45
119717-03070	4	46
		47
119717-11131	4	24
119717-11190	4	26
119717-11200	4	30
119717-11240	4	31
119717-11260	4	34
119717-11320	4	56
119717-11331	4	57
	16	4
119717-11340	4	27
	16	5
119717-11350	4	28
	16	6
119717-11381	4	44
119717-11650	4	36
119717-11800	4	66
119717-13110	5	2
	16	9
119717-13600	5	3
119717-14400	6	2
119717-14581	6	3
119717-21200	7	5
119717-23200	7	31
119717-23601	7	32
119717-23611	7	35
119717-23910	7	34
119717-25050	6	10
119717-25101	6	11
119717-25911	6	17

Parts No.	Fig. No.	Ref. No.
119717-25930	6	16
119717-32050	2	21
	16	13
119717-32060	8	5
	16	14
119717-32080	2	11
119717-32100	2	10
119717-32110	2	15
119717-32120	2	16
119717-34801	8	1
119717-35080	8	6
119717-35140	8	3
119717-39210	8	12
119717-42020	9	13
	16	15
119717-42031	9	3
119717-42041	9	4
119717-49800	9	23
119717-51150	6	18
119717-51420	10	64
119717-51711	10	89
119717-51750	10	90
119717-51761	10	91
119717-51860	10	105
119717-51930	11	2
119717-59510	12	32
119717-61050	11	3
119717-61060	11	95
119717-61070	11	4
119717-77010	14	1
119717-77340	15	28
119717-77801	4	64
119717-77820	4	65
119718-11310	4	55
	16	3
119734-01590	2	4
119740-01770	3	10
119740-13100	5	1
119740-13500	5	9
119740-55600	13	6
119802-03100	4	48
119802-03110	4	49
119802-03121	4	50
119802-03131	4	51
119802-03141	4	52
119802-13620	5	4
119802-32130	2	17
119810-01200	1	13
119810-02941	1	35
119810-55340	13	7

Parts No.	Fig. No.	Ref. No.
119810-55650	13	12
119813-59950	12	44
119840-59570	12	42
119865-21600	7	12
119940-77270	15	27
119C00-61900	11	82
119C10-21650	7	13
119C10-21930	7	15
	16	11
119C10-21940	7	16
119C10-42320	9	9
119C10-51250	11	110
119C10-53000	12	1
119C10-53010	12	3
119C10-77600	15	32
119E00-01560	1	1
119E10-01330	1	14
	16	2
119E10-11100	4	22
119E10-11110	4	23
119E10-11740	4	12
119E10-21700	7	1
119E10-22080	7	19
119E10-22300	7	25
		44
119E10-22500	7	21
119E10-22550	7	40
119E10-22900	7	38
119E10-23000	7	27
119E10-42000	9	1
119E10-59810	12	20
119E10-59820	12	24
119E10-59830	12	28
119E18-22900	7	18
119E18-22910	7	37
119E40-21590	7	9
119E40-92010	16	1
121250-44901	9	38
121250-55620	13	11
121252-39450	8	11
121254-55510	13	8
		21
121256-44600	9	37
121257-55720	13	26
121257-55731	13	27
121450-42450	9	26
121450-44531	9	32
121470-44581	9	34
121520-34810	8	2
121850-51960	2	22

Parts No. Index

Parts No.	Fig. No.	Ref. No.
121850-51960	16	16
121850-55710	13	25
121850-55800	13	17
122710-51090	10	9
123501-79240	15	4
123900-13620	5	5
124060-01050	1	12
124066-59100	12	40
124085-02220	3	5
124160-01751	2	30
	4	43
124160-01910	1	15
124250-49351	9	28
124450-44550	9	36
124450-44560	9	33
124465-44950	9	27
	16	23
128401-77440	15	11
129001-32320	2	13
129001-32330	2	14
129005-59830	8	13
129030-44740	9	19
129052-77380	15	3
129052-77422	15	6
129052-79260	15	17
129052-79270	15	18
129100-01580	3	1
	7	2
129100-52200	10	109
129150-11230	4	37
129150-11750	4	39
129150-25301	6	15
129150-49360	9	29
	16	24
129150-59120	12	15
129150-59131	12	18
129155-51020	10	5
129155-51280	10	54
		55
	11	6
129155-51400	10	62
129155-51580	10	86
129155-51701	10	88
129155-52051	10	108
129155-61460	11	79
129155-77925	15	33
129211-77920	15	34
129350-49530-1	9	22
129400-92420	16	25
129423-77710	15	16

Parts No.	Fig. No.	Ref. No.
129457-44760	9	20
129508-11180	4	25
129900-07900	4	7
129900-32130	2	12
129901-11450	4	9
	16	7
129901-53800	12	4
129901-59560	12	38
	16	17
129916-49740	9	10
129972-77341	15	29
158552-61900	11	83
158600-51270	10	53
158600-51410	10	63
158600-51420	10	65
158600-51570	10	85
158600-51790	10	92
171056-49120	9	25
171064-44510	9	30
22190-080002	8	14
		16
	16	18
22190-100002	11	86
22190-120002	12	50
	13	3
	16	19
22190-160002	3	14
	10	94
	16	22
22217-120000	10	95
22242-000120	4	40
22252-000220	7	26
		45
22351-050010	10	96
22351-060012	4	29
22372-040000	11	88
22512-040120	7	6
		17
22857-500100	4	58
		59
22857-500160	4	60
23010-038000	9	39
23065-070225	9	35
23414-080000	9	14
	16	20
23418-060000	13	30
23857-030000	8	15
23876-005000	4	21
23876-030000	2	8
24311-000320	2	31

Parts No.	Fig. No.	Ref. No.
24311-000320	4	61
	16	21
24311-240100	13	15
		31
24316-000200	11	89
25132-003600	9	18
26022-050122	10	100
26106-060102	8	10
	11	70
		90
26106-060122	2	23
	6	9
26106-060142	11	91
		111
26106-060162	2	24
26106-060202	4	62
	11	92
26106-060352	6	14
26106-060402	2	25
		26
26106-060452	9	21
	11	93
26106-060602	2	27
26106-060652	2	28
26106-060752	4	63
26106-080122	3	15
	9	15
26106-080142	11	112
26106-080162	4	8
26106-080202	9	24
	15	30
26106-080302	3	16
26106-080402	4	42
26106-080452	3	17
26106-080502	3	18
	9	16
26106-100182	5	10
26106-100252	14	35
26106-100452	15	26
26206-100252	3	6
26206-100302	3	7
26306-080002	2	29
	5	7
		11
26366-080002	11	71
26577-060122	9	11
26716-120002	10	102
26756-060002	11	94
26979-050162	4	41
27241-120000	1	16

Parts No.	Fig. No.	Ref. No.
27241-250000	9	12
719717-02901	1	29
719717-02911	1	32
719734-01500	2	5
719E40-51300	10	1
977770-1207F	16	26
X0280210331	14	23
X0280335350	14	33
X0280626010	14	12
X0280996180	14	3
X0281007750	14	2
X0282005991	14	6
X0283006960	14	7
X0284105040	14	13
X0284525010	14	27
X0285007030	14	10
X0285105190	14	4
X0285205030	14	5
X0286105010	14	15
X0286305010	14	17
X0286355010	14	18
X0287405140	14	19
X0534007800	14	20
X1289510130	14	34
X4284001590	14	8
X9055715000	14	21
X9490065670	14	32
X9490138090	14	25
X9490138100	14	26
X9490138110	14	24
X9490423420	14	30
X9490560750	14	29
X9490561001	15	2
X9490562360	14	28
X9490721360	14	22
X9491034320	14	16
X9491034330	14	14
X9491040990	14	11
X9491050100	14	9