

# PARTS CATALOG

Pub. No. K060E1293

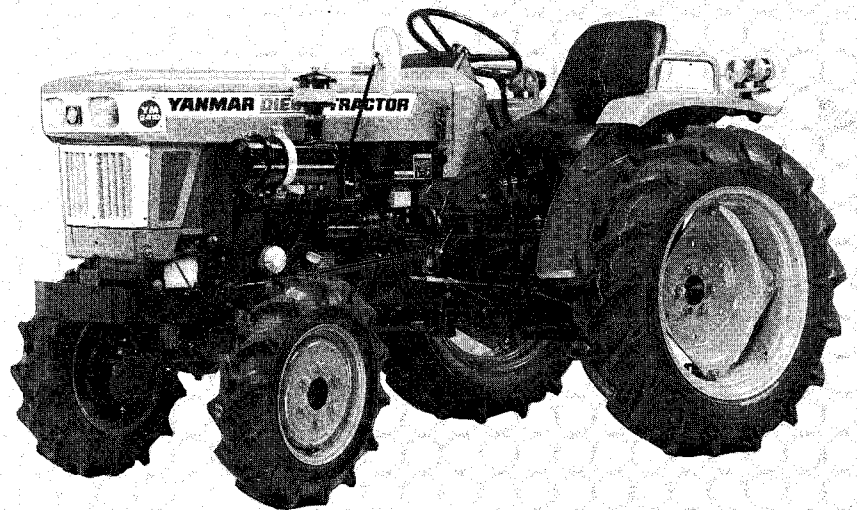

**MODEL**

CONTENTS (1)

Power Transmission Structural Drawing (1) For Model YM241 .....	i
Power Transmission Structural Drawing (2) For Model YM241D .....	ii
Engine Sectional View (1) 2TR20A-YP .....	iii
Engine Sectional View (2) 2TR20A-YP .....	iv
Travelling Transmission Sectional View (1) For Model YM241 .....	v
Travelling Transmission Sectional View (2) For Model YM241D .....	vi
Travelling Transmission Sectional View (3) For Model YM241/YM241D .....	vii
Travelling Front Driving Sectional View For Model YM241D .....	viii
Wiring Diagram .....	ix

— Components —

ENGINE PARTS

Fig.		Page
1.	Cylinder Block .....	1
2.	Gears Housing .....	5
3.	Cylinder Head .....	9
4.	Air Cleaner (With Pre-Cleaner) .....	13
5.	Silencer .....	17
6.	Camshaft .....	19
7.	Main Bearing & Crankshaft .....	21
8.	Piston & Connecting Rod .....	25
9.	Lubricating Oil System .....	27
10.	Cooling Water System .....	29
11.	Fuel Injection Pump .....	33
12.	Fuel Injection Valve .....	37
13.	Fuel Oil System .....	39
14.	Governor System .....	43
15.	Electric Starting System .....	47
16.	Starter (12V-1.3kW) Type S114-146 .....	49
17.	AC Generator (12V-15A) Type LT115-52 .....	53
18.	Thermostart Device .....	55
19.	Gasket Kit (For Engine) .....	57

CHASSIS PARTS

20.	Underslung Exhaust Silencer .....	61
21.	Throttle .....	63
22.	Fuel Tank .....	67
23.	Front Axle Bracket [For Model YM241] .....	71
24.	Front Axle Bracket [For Model YM241D] .....	73
25.	Front Axle [For Model YM241] .....	75
26.	Propeller Shaft of Front Axle [For Model YM241D] .....	79
27.	1st Shaft & Ring Gear of Front Axle [For Model YM241D] .....	83
28.	Casing of Front Axle [For Model YM241D] .....	87
29.	2nd Shaft & Spindle of Front Axle [For Model YM241D] .....	91
30.	Steering [For Model YM241] .....	95
31.	Steering [For Model YM241D] .....	99
32.	Clutch Housing [For Model YM241] .....	103
33.	Clutch Housing [For Model YM241D] .....	107
34.	Transmission Housing [For Model YM241] .....	111
35.	Transmission Housing [For Model YM241D] .....	115
36.	Transmission Gears .....	119
37.	Shift Levers .....	123
38.	Front Drive & Shift .....	127
39.	Differential Gears of Rear Axle .....	131
40.	Rear Axle Housing .....	135
41.	Brakes .....	139
42.	Hydraulic Pipes .....	143
43.	Hydraulic Cylinder .....	147
44.	Hydraulic Lift .....	151
45.	Hydraulic Control Valve .....	153
46.	Oil Pressure Control .....	157
47.	Draft Control .....	161
48.	Electric Parts .....	165
49.	Hood .....	171
50.	Fender .....	175
51.	Seat .....	179
52.	Three Point Hitch .....	181
53.	Rear Hitch .....	185
54.	Tools .....	187
55.	Tires (Front & Rear) [For Model YM241] .....	189
56.	Tires (Front & Rear) [For Model YM241D] .....	193
57.	Labels .....	197
58.	Large Tires (Front & Rear) .....	201
	Numerical Part No. List .....	205

POWER TRANSMISSION STRUCTURAL DRAWING (1) FOR MODEL YM241

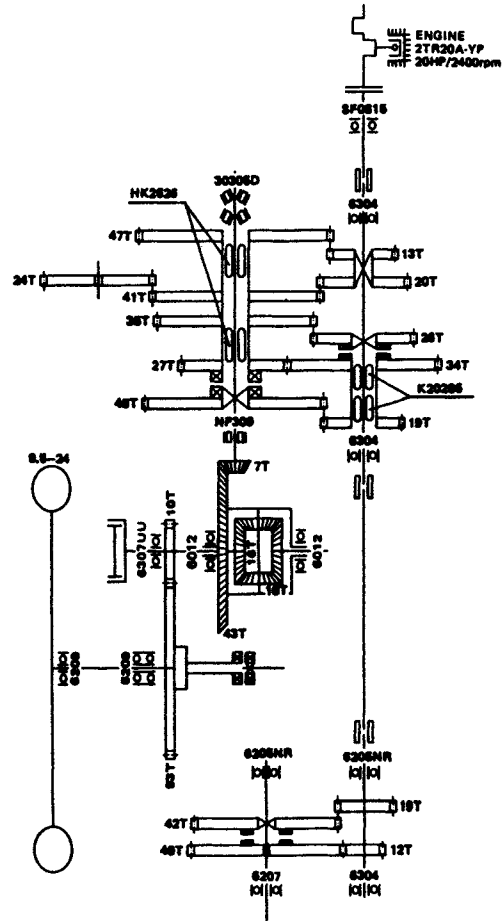

POWER TRANSMISSION STRUCTURAL DRAWING (2) FOR MODEL YM241D

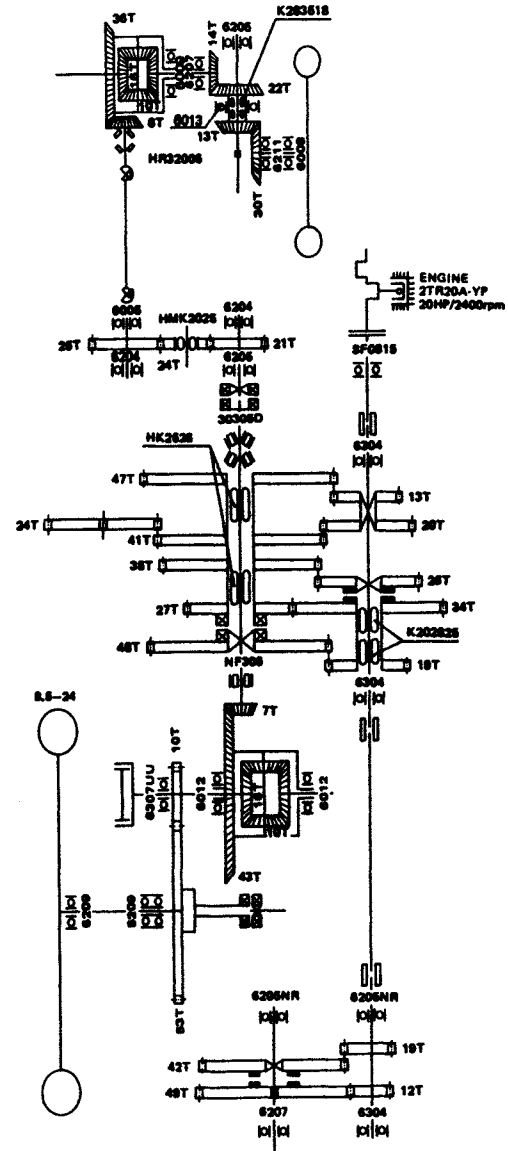

ENGINE SECTIONAL VIEW (1) 2TR20A-YP

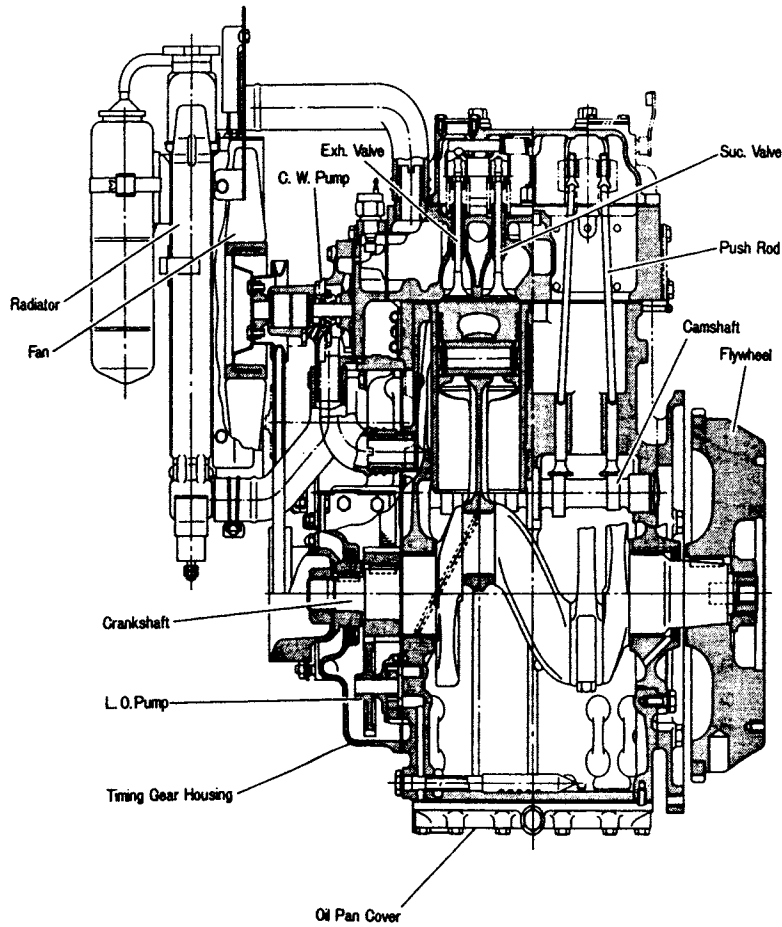

ENGINE SECTIONAL VIEW (2) 2TR20A-YP

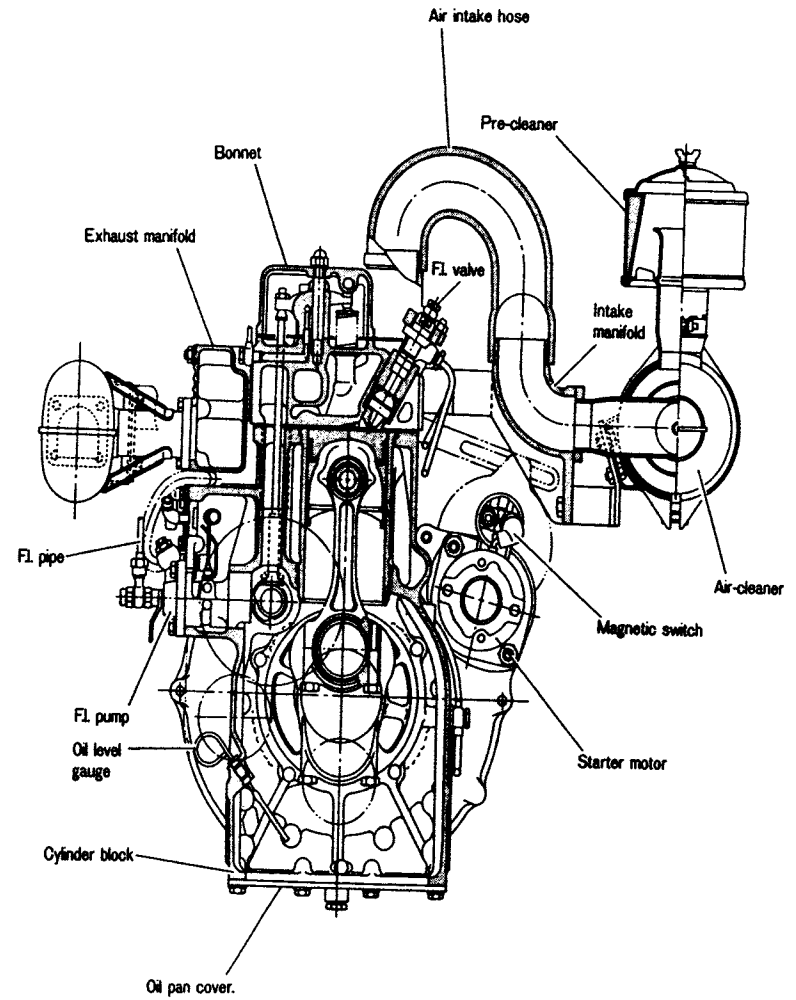

TRAVELLING TRANSMISSION SECTIONAL VIEW (1) FOR MODEL YM241

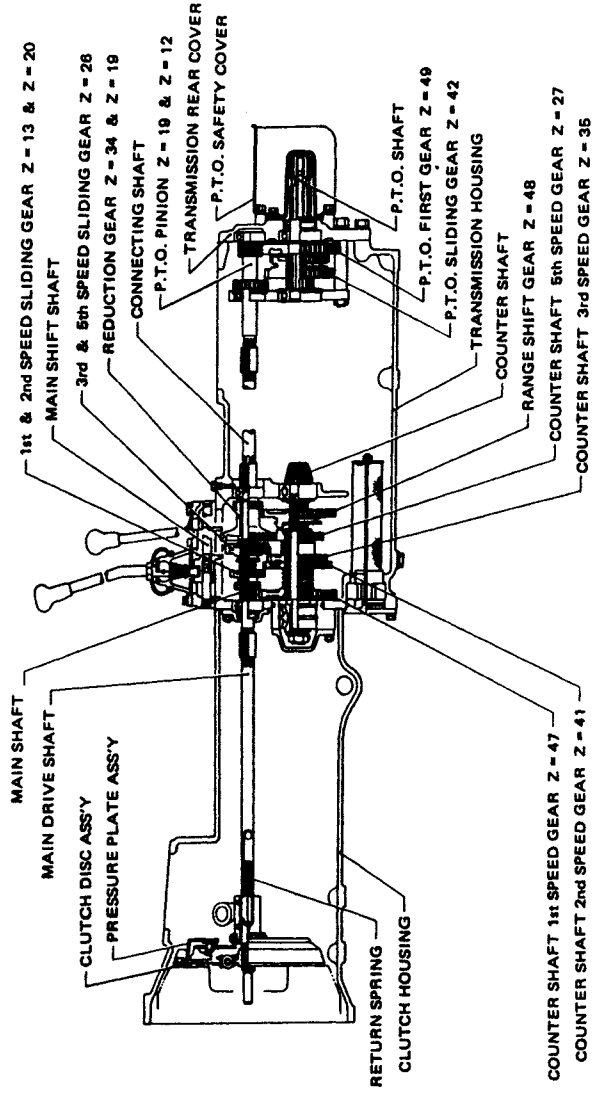

TRAVELLING TRANSMISSION SECTIONAL VIEW (2) FOR MODEL YM241D

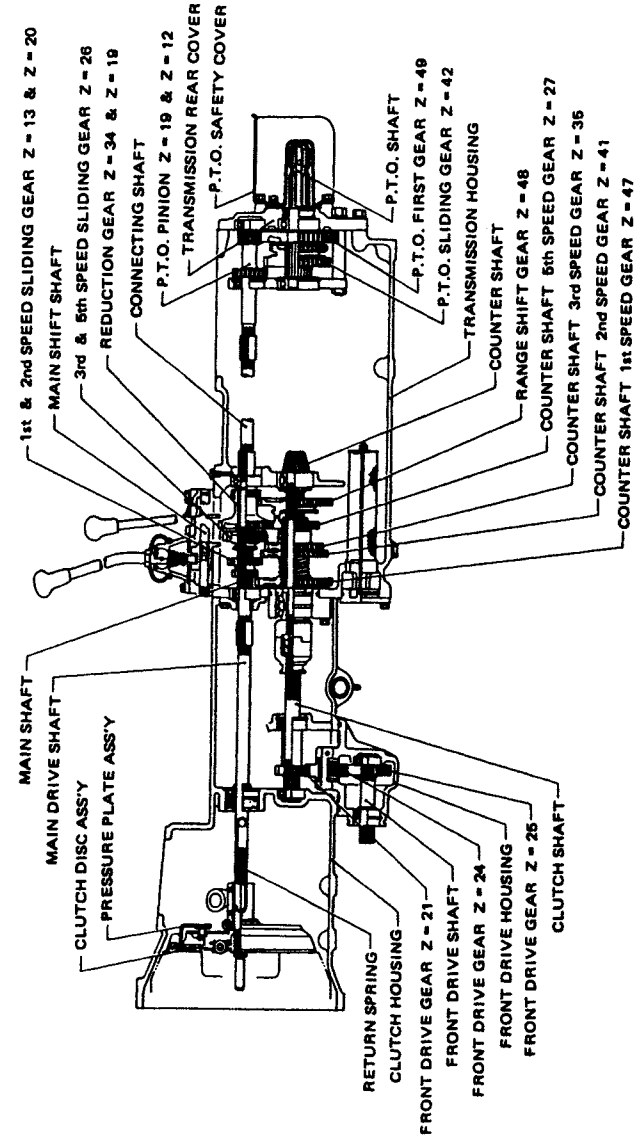

TRAVELLING TRANSMISSION SECTIONAL VIEW (3) FOR MODEL YM241/YM241D

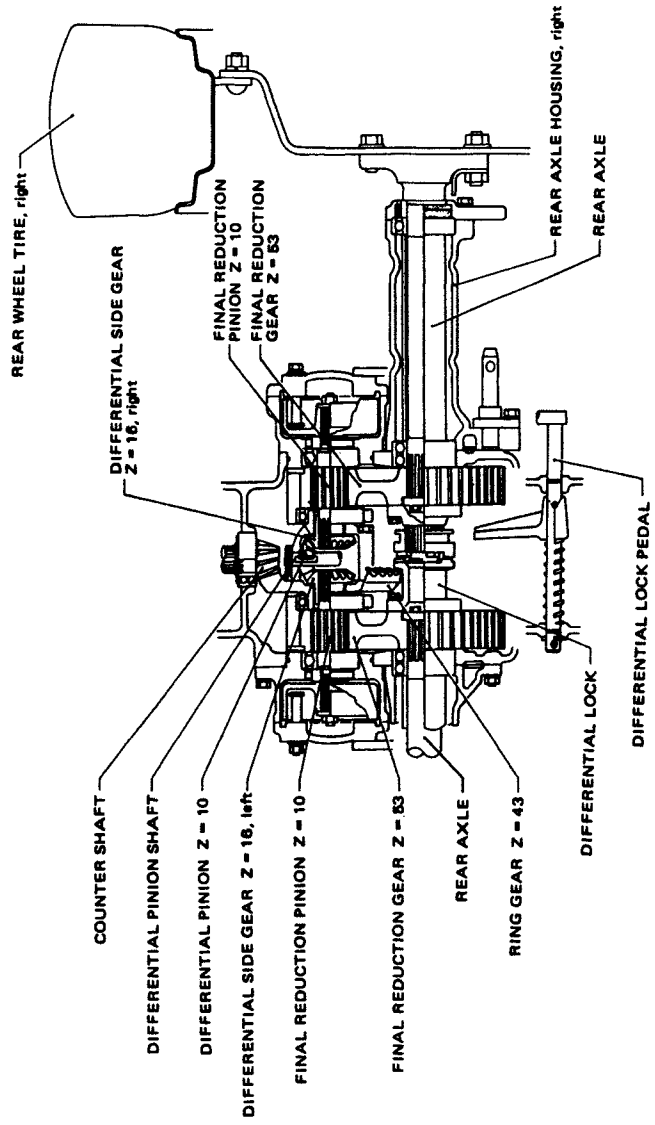

TRAVELLING FRONT DRIVING SECTIONAL VIEW FOR MODEL YM241D

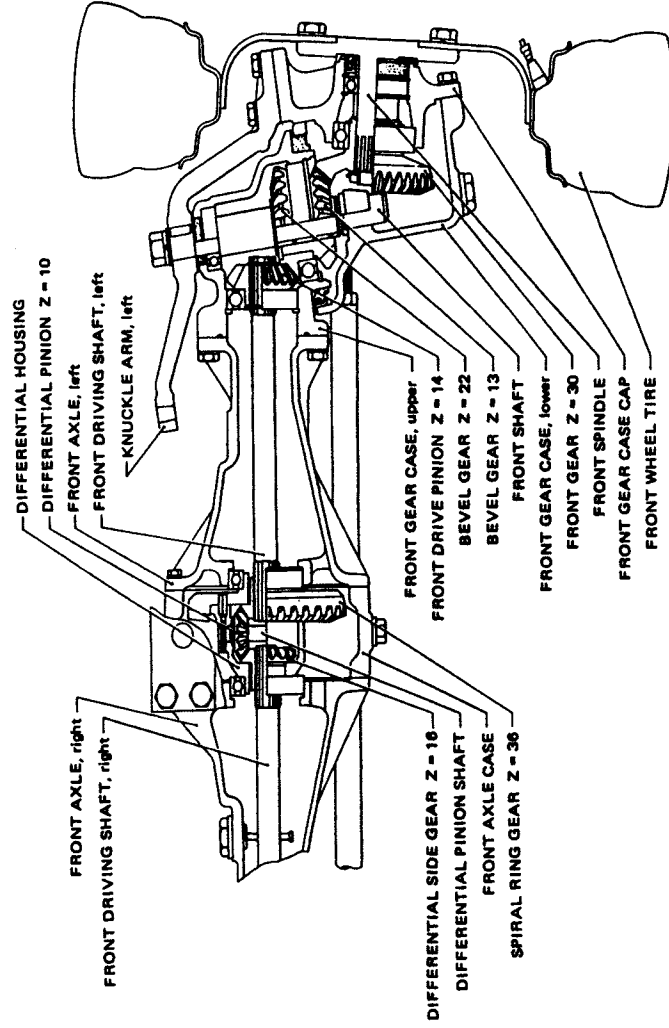

1A7

WIRING DIAGRAM

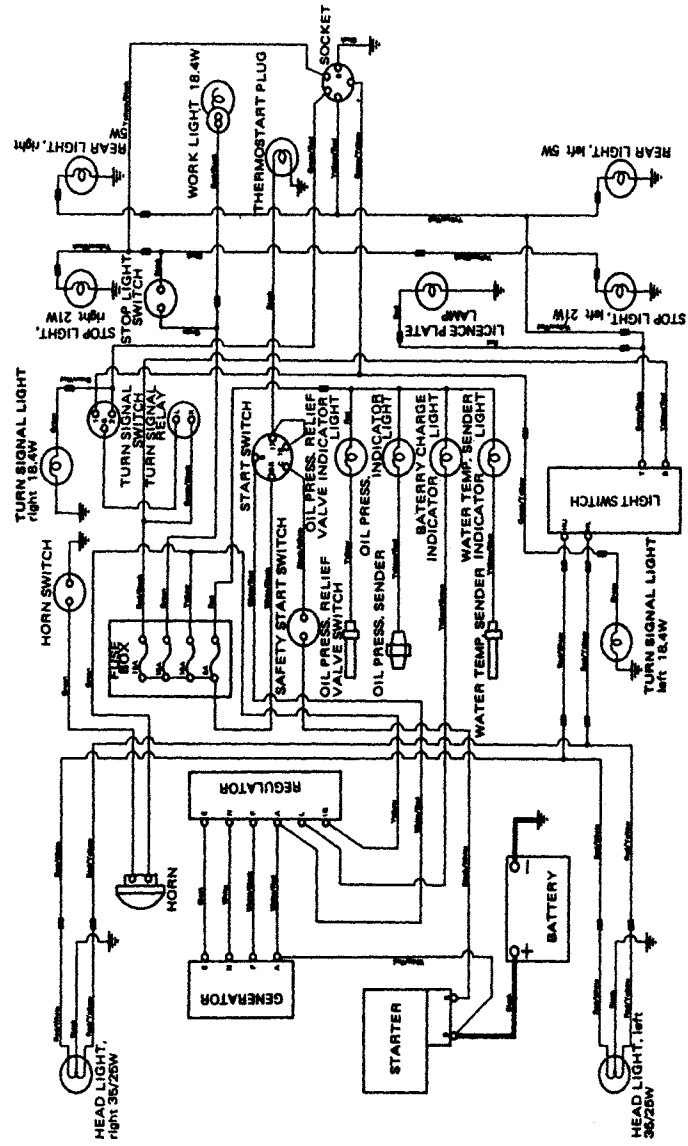

**ENGINE PARTS**

**Type 2TR20A-YP**





Fig.1 CYLINDER BLOCK

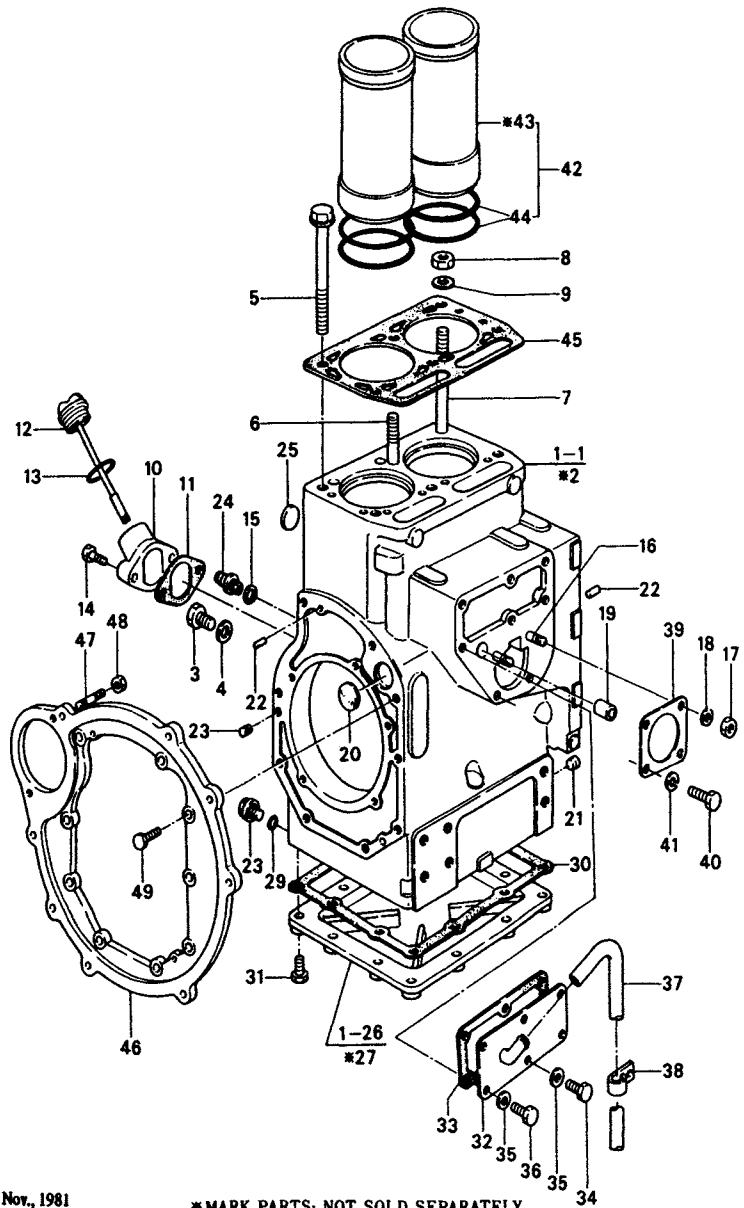

Nov., 1981

\* MARK PARTS: NOT SOLD SEPARATELY.

Fig. 1 CYLINDER BLOCK

Refer. No.	Description	Part No.	Q'ty/Unit		Sales Unit	Interchangeability	Designchange Mark	Remarks
			STR	20A-VP (Y/M)				
1- 1	BLOCK ASS'Y, cylinder	Z-724465-01561	1					
1- 2	.BLOCK, cylinder	*	1		*			Order ASS'Y (124465-01011)
1- 3	.PLUG M10	23883-100002	1		10			
1- 4	.PACKING 10	121250-01990	1		10			
1- 5	.BOLT(A), cylinder head M15-115L	124450-01211	4					
1- 6	.STUD(B), cyl. head M15-80L	124450-01220	1					
1- 7	.STUD(C), cyl. head M15-156L	124450-01230	1					
1- 8	.NUT, cylinder head M15-14t	124450-01250	2		10			
1- 9	.WASHER 26d-4t	124450-01240	2		10			
1- 10	.FLANGE, oil feed	Z-121250-01522	1					
1- 11	.PACKING, flange	124160-34844	1		10			
1- 12	.CAP w/DIPSTICK	121250-01791	1					
1- 13	.O-RING 35-G	24321-000350	1		10			
1- 14	.BOLT M8x35	26116-080352	2		10			
1- 15	.PACKING 14	124450-01980	1		10			
1- 16	.STUD M8x22	26216-080222	2		10			For F.I.pump
1- 17	.NUT M8	26716-080002	2		10			For F.I.pump
1- 18	.SEAL WASHER 8	43400-500410	2		10			
1- 19	.BUSH, regulator handle shaft 16d-15L	124550-01900	1		10			
1- 20	.PLUG 40	27233-400000	1		10			
1- 21	.PLUG PF1/4	124160-01910	1		10			
1- 22	.PARALLEL PIN 8x16	22312-080160	4		10			
1- 23	.PLUG PT1/8	124060-01050	2		10			
1- 24	.JOINT, c.w. pipe	121250-49110	1					
1- 25	.PLUG 40	27233-400000	1		10			

Nov., 1981

Nov., 1981

Fig. 1 CYLINDER BLOCK

Refer. No.	Description	Part No.	Q'ty/Unit		Sales Unit	Interchangeability	Designchange Mark	Remarks
			2TR 30A-YP (YM241)					
1- 26	PAN ASS'Y, lub. oil	Z-724465-01541	1					
1- 27	.PAN, lub. oil	*	1		*			Order ASS'Y (124465-01701)
1- 28	.PLUG M12	124060-01640	1					
1- 29	.O-RING 14-P	24311-000140	1		10			
1- 30	PACKING, oil pan	124465-01751	1		10			
1- 31	BOLT M8x25	26116-080252	16		10			
1- 32	COVER, f.i.pump room	Z-121250-01850	1					
1- 33	PACKING, f.i.pump room 156L-63.5w	124160-01863	1		10			
1- 34	BOLT M6x14	26116-060142	4		10			
1- 35	WASHER 6	22137-060000	6		10			
1- 36	BOLT M6x14	26116-060142	2		10			
1- 37	PIPE 9x560	23065-090560	1		10			
1- 38	CLAMP, breather pipe	124160-01650	1					
1- 39	SHIM SET, f.i.pump t=0.3,0.2	124550-51951	1					
1- 40	BOLT M8x22	26116-080222	2		10			Fuel injection pump fitting.
1- 41	SPRING WASHER 8	22217-080000	2		10			
1- 42	LINER w/PACKING, cyl.	724763-01900	2					
1- 43	.LINER, cylinder	*	2		*			Order ASS'Y (124763-01100)
1- 44	.PACKING, cyl. liner	124550-01300	4		10			
1- 45	GASKET, cyl. head	124763-01330	1		5			
1- 46	FLANGE, mounting	Z-124465-01600	1					
1- 47	STUD M12x25, starter	124450-01610	2					
1- 48	NUT M12	26716-120002	2		10			
1- 49	BOLT M10x32	26116-100322	9		10			

Fig.2 GEARS HOUSING

GEAR STRUCTURAL DRAWING

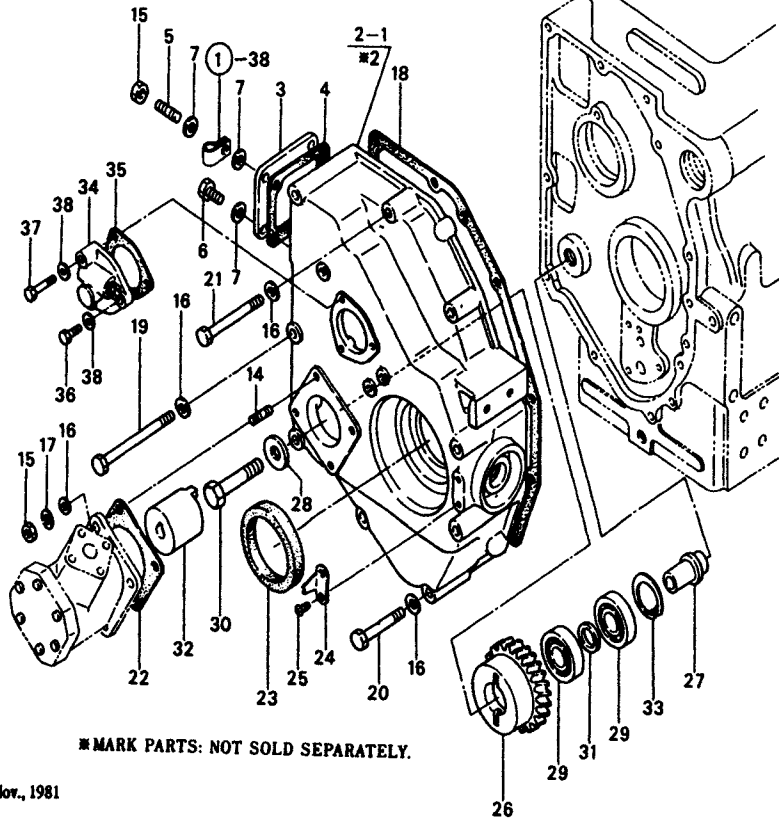
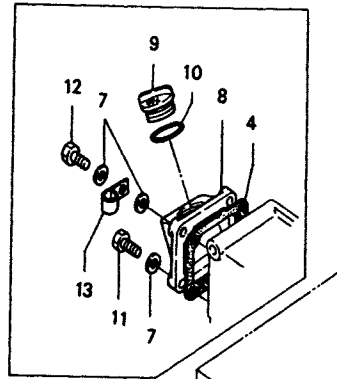
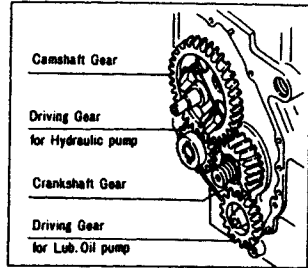

Nov., 1981

Fig. 2 GEARS HOUSING

Refer. No.	Description	Part No.	Qty/Unit		Sales Unit	Interchangeability	Designchange Mark	Remarks
			778 26A-7P (W241)					
2- 1	HOUSING ASS'Y, gears	Z-724160-01612	1					
2- 2	.HOUSING, gears	*	1		*			Order ASS'Y (124160-01502)
2- 3	.COVER, side	Z-124450-11671	1					
2- 4	.PACKING, cover	124160-01532	1		10			
2- 5	.STUD M8x14	26216-080142	2		10			
2- 6	.BOLT M8x12	26116-080122	2		10			
2- 7	.PACKING 8	23414-080000	5		10			
2- 8	.BRACKET, oil feed	124160-01521	(1)					\$
2- 9	.CAP, oil feed	124160-01751	(1)					\$
2- 10	.O-RING 35-G	24321-000350	(1)					\$
2- 11	.BOLT M8x16	26116-080162	(3)					\$
2- 12	.BOLT M8x22	26116-080222	(1)					\$
2- 13	.CLAMP, breather pipe	124160-01650	(1)					\$
2- 14	STUD M8x22	26216-080222	4		10			
2- 15	NUT M8	26716-080002	6		10			
2- 16	WASHER 8	22137-080000	13		10			
2- 17	SPRING WASHER 8	22217-080000	4		10			
2- 18	PACKING, gear housing	124450-01511	1					
2- 19	BOLT M8x100	26116-081002	5		10			
2- 20	BOLT M8x50	26116-080502	2		10			
2- 21	BOLT M8x60	26116-080602	2		10			
2- 22	PACKING, hydraulic pump	124240-01882	1		10			
2- 23	SEAL HTC 58 80 12, oil crankshaft	124450-01800	1					
Remarks: \$-marked parts: In the case of fitting the GEARS HOUSING ASS'Y, extract Refer.No.2-8 to 2-13 from ASS'Y, because unnecessary.								

Nov., 1981

Nov., 1981

Fig. 2 GEARS HOUSING

Refer. No.	Description	Part No.	Qty/Unit		Sales Unit	Interchange-ability	Designchange Mark	Remarks
			STR 20A-YP (M241)					
2- 24	POINTER, crankshaft V-pulley	124450-07300	1					
2- 25	SCREW M6x10	26557-060102	2		10			
2- 26	GEAR, pump driving	121250-26201	1					
2- 27	SHAFT, driving gear	121250-26400	1					
2- 28	WASHER 12, shaft 24d-4t	124450-26410	1					
2- 29	BALL BEARING #6004	24101-060044	2					
2- 30	BOLT M12x65	26116-120652	1		10			
2- 31	SPACER, ball bearing 27.2d-3t	121250-26210	1					
2- 32	CONNECTOR, hyd. oil pump	121250-26160	1					
2- 33	CIRCLIP 42-H	22252-000420	1					
2- 34	GEAR UNIT, tachometer	2-124250-91400	1					
2- 35	PACKING, gear unit	124250-91412	1		10			
2- 36	BOLT M6x16	26116-060162	2		10			
2- 37	BOLT M6x32	26116-060326	1		10			
2- 38	PACKING 6	23414-060000	3		10			

Fig.3 CYLINDER HEAD

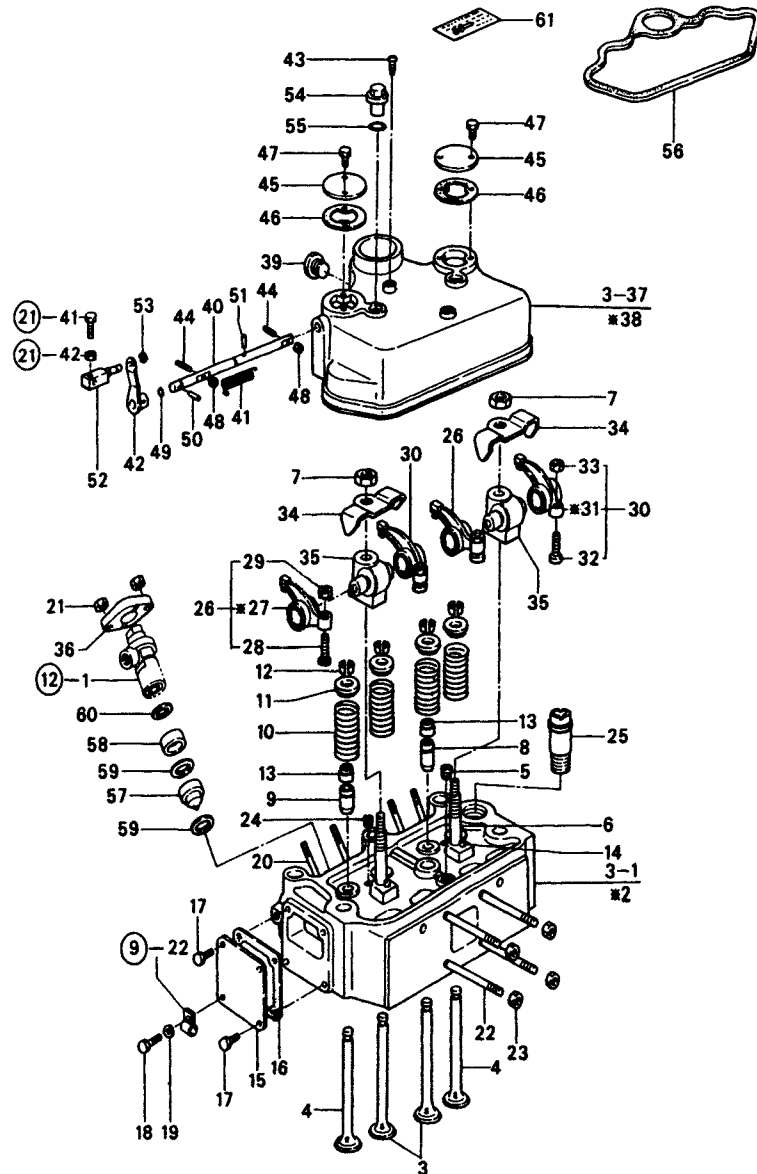

Nov., 1981

\* MARK PARTS: NOT SOLD SEPARATELY.

Fig. 3 CYLINDER HEAD

Refer. No.	Description	Part No.	Q'ty/Unit		Sales Unit	Interchangeability	Designation Part	Remarks
			STR 20A-VP (7M241)					
3- 1	HEAD ASS'Y, cylinder	Z-724764-11700	1					
3- 2	.HEAD, cylinder	*	1		*			Order ASS'Y (124764-11010)
3- 3	.VALVE, suction	104600-11100	2		10			
3- 4	.VALVE, exhaust	104600-11110	2		10			
3- 5	.TAPER PLUG PT1/2	23873-040000	1		10			
3- 6	.STUD, support	104700-11350	2		10			
3- 7	.NUT M12	124460-11270	2		10			
3- 8	.GUIDE, suction valve	124450-11161	2		10			
	.GUIDE, suction valve	124450-11800	2		10	c		
3- 9	.GUIDE, exhaust valve	124450-11171	2		10			
	.GUIDE, exhaust valve	124450-11810	2		10	c		
3- 10	.SPRING, valve	124450-11120	4		10			
3- 11	.RETAINER, valve spring	103338-11180	4		10			
3- 12	.COTTER, valve spring	27310-080000	4		10			
	.COTTER, valve spring	27310-080001	4		10	c		
3- 13	.SEAL, valve stem	124460-11340	4		10			
3- 14	.SPRING PIN 6x14	22351-060014	2		10			
3- 15	.COVER, side	Z-124450-11671	1					Flywheel side.
3- 16	.PACKING, side cover	124450-11681	1		10			
3- 17	.BOLT M8x12	26116-080122	3		10			
3- 18	.BOLT M8x14	26116-080142	1		10			
3- 19	.WASHER 8	22137-080000	1		10			
3- 20	.STUD M8x60	26216-080602	4		10			For F.I.valve
3- 21	.NUT M8	26716-080002	4		10			For F.I.valve
3- 22	.STUD M8x75	26216-080752	4		10			
3- 23	.NUT M8	26716-080002	4		10			

Nov., 1981

Nov., 1981

Fig. 3 CYLINDER HEAD

Refer. No.	Description	Part No.	Q'ty/Unit		Sales Unit	Interchange-ability	Designation Mark	Remarks
			STR 26A-YP (FM241)					
3- 24	.TAPER PLUG PT1/4	23873-020000	2		10			
3- 25	.JOINT, c.w.pipe	124160-49480	1					
3- 26	ARM ASS'Y, rocker	724450-11650	2				No.1 exh. & No.2 suc. Order ASS'Y (124450-11380)	
3- 27	.ARM w/BUSH	*	2	*				
3- 28	.SCREW, valve clearance	101158-11230	2		10			
3- 29	.LOCK NUT M8	26756-080002	2		10			
3- 30	ARM ASS'Y, rocker	724450-11660	2				No.1 suc. & No.2 exh. Order ASS'Y (124450-11390)	
3- 31	.ARM w/BUSH	*	2	*				
3- 32	.SCREW, valve clearance	101158-11230	2		10			
3- 33	.LOCK NUT M8	26756-080002	2		10			
3- 34	RETAINER, rocker arm	124450-11290	2		10			
3- 35	SUPPORT w/BALL, rocker arm	124450-11250	2					
3- 36	FLANGE, fuel injection	173400-11900	2					
3- 37	BONNET ASS'Y, cyl.	Z-724460-11521	1					
3- 38	.BONNET, cyl.	*	1	*			Order ASS'Y (124460-11980) For thermostart plug screw hole.	
3- 39	.PLUG U7/8	124450-11320	1		10			
3- 40	.SHAFT, decompression 10d-214L	124450-03600	1					
3- 41	.SPRING, decompression 13d-36L	124250-03621	1		10			
3- 42	.LEVER, decompression	Z-124465-03610	1					
3- 43	.LOCK SCREW, shaft	124250-03640	1		10			
3- 44	.SCREW, adjusting M5-21L	120220-03660	2		10			
3- 45	.COVER	124460-03650	2					

Nov, 1981

- 11 -

Nov, 1981

Fig. 3 CYLINDER HEAD

Refer. No.	Description	Part No.	Q'ty/Unit		Sales Unit	Interchange-ability	Designation Mark	Remarks
			STR 26A-YP (FM241)					
3- 46	.PACKING,adjust cover	124460-03663	2		10			
3- 47	.BOLT M6x10	26116-060102	4		10			
3- 48	.LOCK NUT M5	26756-050002	2		10			
3- 49	.O-RING 7-P	24311-000070	1		10			For decomp.shaft
3- 50	.TAPER PIN 3x18	22322-030180	1		10			For decomp.lever
3- 51	.TAPER PIN 3x14	22322-030140	1		10			For decomp. spring
3- 52	.FITTINGS	121250-03783	1		10			
3- 53	.SNAP RING 6	22272-000060	1		10			
3- 54	.CAP, bonnet	124460-11360	2					
3- 55	.O-RING 14-P	24311-000140	2		10			
3- 56	PACKING, bonnet	124450-11310	1		10			
3- 57	CHAMBER(FRONT), pre-combus.	124750-11401	2					
3- 58	CHAMBER(REAR), pre-combus.	104900-11410	2					
3- 59	PACKING, chamber	104900-11450	4		10			
3- 60	INSULATOR, heat	103854-11490	2		10			
3- 61	LABEL, valve adjusting	124742-11310	1		10			

Nov, 1981

- 12 -

Nov, 1981

Fig. 4 AIR CLEANER (With Pre-Cleaner)

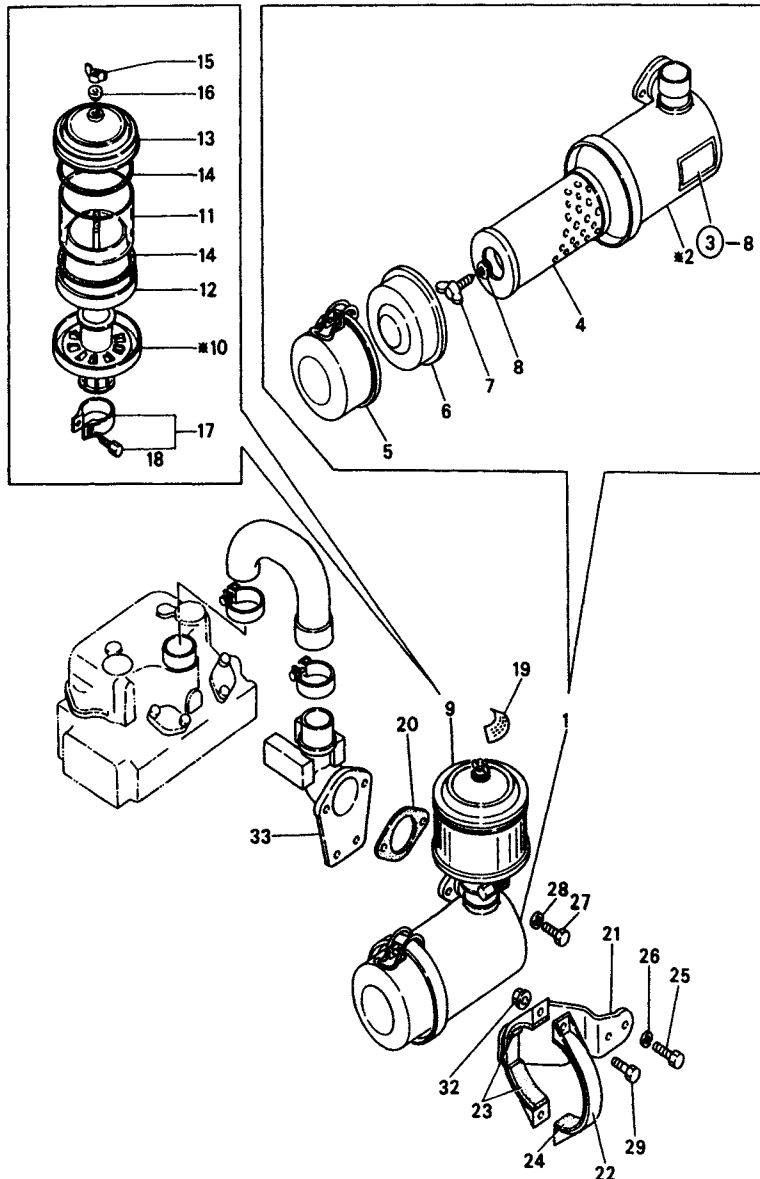

\* MARK PARTS: NOT SOLD SEPARATELY.

Fig. 4 AIR CLEANER (with Pre-cleaner)

Refer. No.	Description	Part No.	Qty/Unit		Sales Unit	Interchangeability	Designchange Mark	Remarks
			2TR 20A-YP (YM341)					
4- 1	CLEANER ASS'Y, air	121253-12300	1					
4- 2	.BODY, air cleaner	*	1		*			Order ASS'Y (121253-12520)
4- 3	.ELEMENT, air cleaner	121253-12510	1					
4- 4	.PAN, dust	121253-12530	1					
4- 5	.BAFFLE	121120-12540	1					
4- 6	.BOLT, wing	121120-12560	1		10			
4- 7	.WASHER, seal	121120-12570	1		10			
4- 8	LABEL, air cleaner	124742-12480	1		10			
4- 9	PRE-CLEANER ASS'Y	115h 124064-12400	1					
4- 10	.BODY, pre-cleaner	128d *	1		*			Order ASS'Y (124064-12410)
4- 11	.TUBE	124d 124064-12420	1					
4- 12	.CASE w/GASKET	124064-12470	1					Inc. 4-14.
4- 13	.COVER (UPPER) w/GASKET	124064-12440	1					Inc. 4-14.
4- 14	..GASKET, tube	124064-12430	2		10			
4- 15	.WING NUT	101147-12550	1		10			
4- 16	.SEAL WASHER	124450-12571	1		10			
4- 17	.CLAMP, pre-cleaner	124064-12450	1					
4- 18	..BOLT, clamp	124064-12460	1					
4- 19	LABEL, pre-cleaner	124742-12520	1		10			
4- 20	PACKING, air cleaner 98L-0.5t	124767-12050	1		10			
4- 21	BRACKET, air cleaner	Z-121253-12110	1					
4- 22	BRACE(B), cleaner	Z-124764-12560	1					
4- 23	SEAT(A), brace	124764-12570	2		10			
4- 24	SEAT(B), brace	124764-12580	1		10			
4- 25	BOLT M8x20	26116-080202	2		10			
4- 26	SPRING WASHER 8	22217-080000	2		10			



Fig. 4 AIR CLEANER (with Pre-cleaner)

Refer. No.	Description	Part No.	Qty/Unit		Sales Unit	Interchangeability	Discharge Mark	Remarks
			JTR MA-YP (1M241)					
4- 27	BOLT M8x25	26116-080252	2		10			
4- 28	SPRING WASHER 8	22217-080000	2		10			
4- 29	BOLT M8x25	26116-080252	2		10			
4- 30	BOLT M8x105	26116-081052	2		10			
4- 31	SPRING WASHER 8	22217-080000	2		10			
4- 32	NUT M8	194990-22050	2		10			
4- 33	BRACKET, air cleaner	Z-124767-12100	1					
4- 34	CLAMP 70	23000-070000	2					
4- 35	PIPE 64Loa-54d-78L	124767-12040	1					

Fig.5 SILENCER

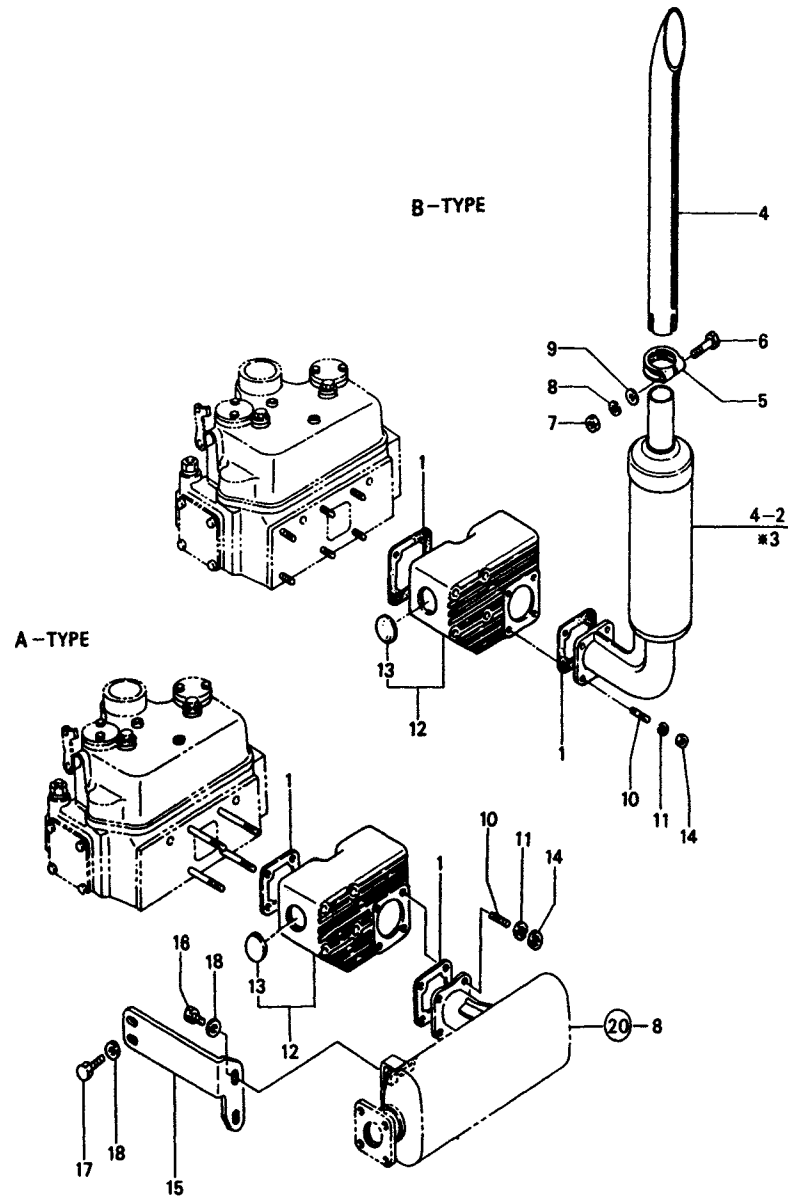

Nov., 1981

\* MARK PARTS: NOT SOLD SEPARATELY.

Fig. 5 SILENCER

Refer. No.	Description	Part No.	Qty/Unit		Sales Unit	Interchangeability Mark	Designation Mark	Remarks
			ZTR 204-YP (A)	ZTR 204-YP (B)				
5- 1	GASKET, silencer	124450-11900	2	2	10			
5- 2	2nd SILENCER ASS'Y, exhaust	724767-13700		1				Order ASS'Y (124767-13500)
5- 3	.2nd SILENCER, exhaust	*		1	*			
5- 4	.PIPE, 2nd silencer	121120-13570		1				
5- 5	.CLAMP	121120-13580		1				
5- 6	.BOLT M10x65	26116-100652		1	10			
5- 7	.NUT M10	26716-100002		1	10			
5- 8	.SPRING WASHER 10	22217-100000		1	10			
5- 9	.WASHER 10	22117-100000		1	10			
5- 10	STUD M8x22	26216-080222	4	4	10			
5- 11	SPRING WASHER 8	22217-080000	4	4	10			
5- 12	1st SILENCER, exhaust	124764-13510	1	1				
5- 13	.PLUG 35	27233-350000	1	1	10			
5- 14	NUT M8	26716-080002	4	4	10			
5- 15	STAY, silencer	124742-13530	1					
5- 16	BOLT M8x12	26116-080122	2		10			
5- 17	BOLT M8x16	26116-080162	2		10			
5- 18	WASHER 8	22117-080000	4		10			

Note: Select either A-type(under slung) or B-type(standing) of the Exhaust Silencers.

Fig. 6 CAMSHAFT

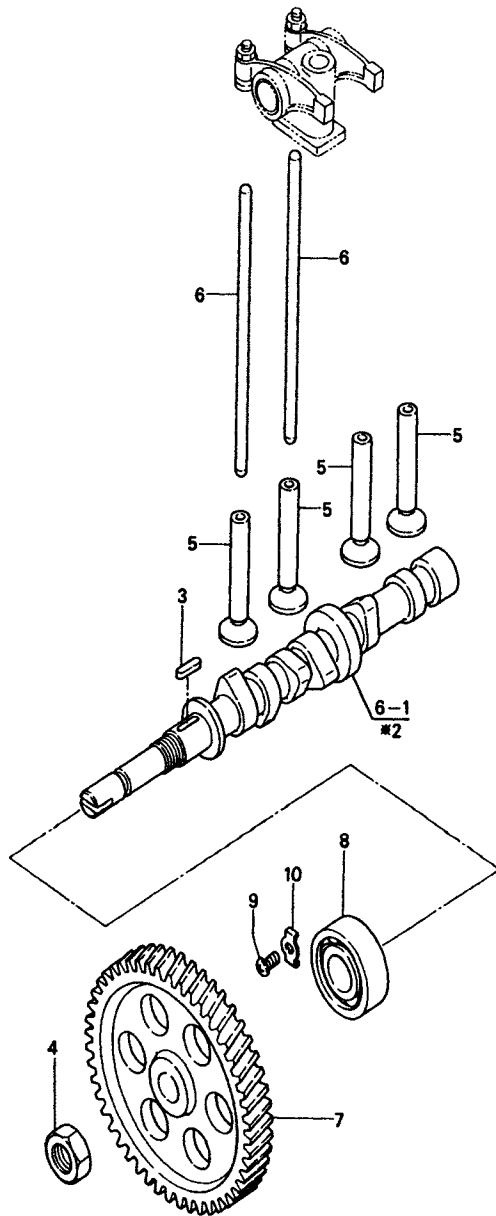

\* MARK PARTS: NOT SOLD SEPARATELY.

Fig. 6 CAMSHAFT

Refer. No.	Description	Part No.	Q'ty/Unit		Sales Unit	Interchangeability	Designchange Mark	Remarks
			1TR	30A-YP (VM241)				
6- 1	CAMSHAFT ASS'Y	724465-14580	1					
6- 2	.CAMSHAFT 34d-355L	*	1		*			Order ASS'Y (124465-14010)
6- 3	.KEY 7x7x18	22512-070180	1		10			
6- 4	.NUT, camshaft gear fitting M24-10t	124450-14120	1		10			
6- 5	TAPPET	103338-14200	4					
6- 6	ROD, valve push 7d-196L	124450-14400	4					
6- 7	GEAR, camshaft 165d-21t	121250-14100	1		10			
6- 8	BALL BEARING #6206	24101-062064	1					
6- 9	SCREW M8x12	26587-080122	1		10			For retainer.
6- 10	RETAINER, ball bearing	121250-02450	1		10			

Fig.7 MAIN BEARING & CRANKSHAFT

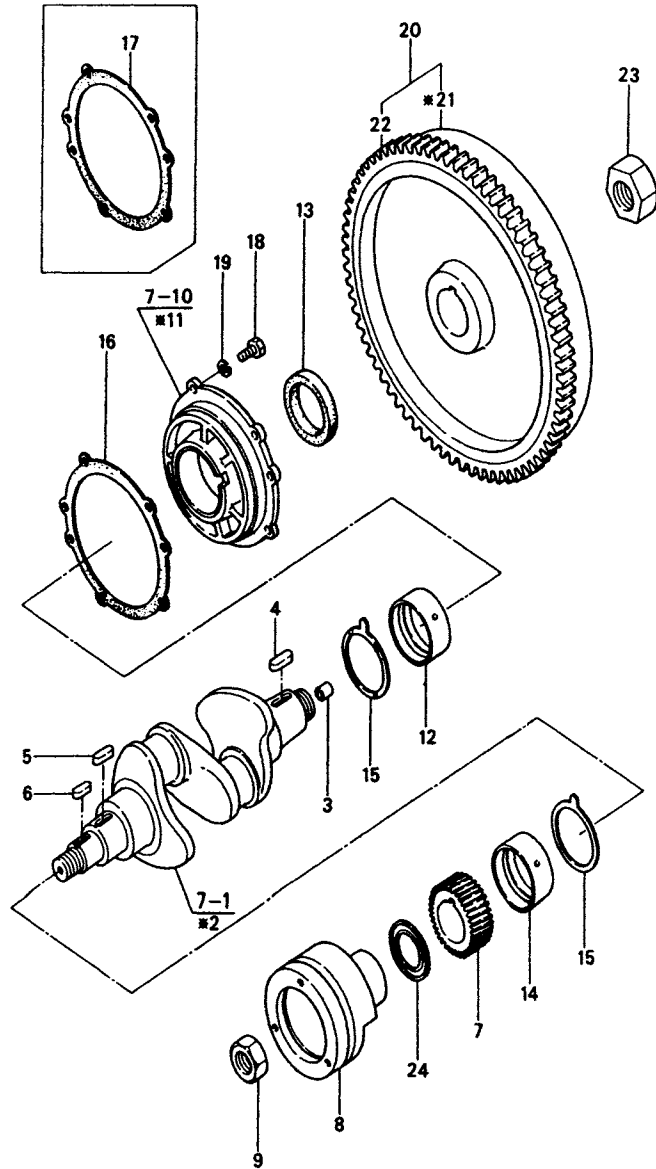

\*MARK PARTS: NOT SOLD SEPARATELY.

Nov., 1981

Fig. 7 MAIN BEARING & CRANKSHAFT

Refer. No.	Description	Part No.	Qty/Unit		Sales Unit	Interchangeability	Designchange Mark	Remarks
			3FR 30A-YP (YM241)					
7- 1	CRANKSHAFT ASS'Y	724764-21700	1					
7- 2	.CRANKSHAFT	*	1		*			Order ASS'Y (124450-21012)
7- 3	.BUSH, pilot	124450-21230	1		10			
7- 4	.KEY 10x8x36	22512-100362	1		10			For flywheel
7- 5	.KEY 7x7x28	22512-070282	1		10			For crankshaft gear
7- 6	.KEY 7x7x24	22512-070242	1		10			For V-pulley
7- 7	GEAR, crankshaft 85d-39t	121250-21200	1					
7- 8	V-PULLEY, P.T.O. crankshaft	124460-21651	1					
7- 9	NUT M30, plated	124160-21670	1		10			For V-pulley
7- 10	HOUSING ASS'Y, main bearing	724465-02500	1					
7- 11	.HOUSING, main bearing	*	1		*			Order ASS'Y (124465-02010)
7- 12	.MAIN BEARING	121250-02100	1					
7- 13	.OIL SEAL, crankshaft	124085-02220	1					
7- 14	MAIN BEARING, V-pulley side	121250-02100	1					
7- 15	THRUST BEARING	124450-02110	2					
7- 16	PACKING, main brg. housing t=0.3	124460-02150	1		10			Standard
7- 17	PACKING, main brg. housing t=0.1	124460-02160	1		10			For adjustment
7- 18	BOLT M10x25	26116-100252	5		10			
7- 19	SPRING WASHER 10	22217-100000	5		10			
7- 20	FLYWHEEL w/RING GEAR	124450-21591	1					
7- 21	.FLYWHEEL	*	1		*			Order ASS'Y (124450-21401)
7- 22	.GEAR, ring	124550-21600	1					
7- 23	NUT, end M36-27t	124450-21530	1					
7- 24	DISC, oil shield	124160-21700	1					

Nov., 1981

Nov., 1981

Fig. 7 MAIN BEARING & CRANKSHAFT

Refer. No.	Description	Part No.	Qty/Unit		Sales Unit	Interchangeability	Designchange Mark	Remarks
			STR 20A-YP (YM341)					
7- 12 7- 14	"Exclusive Spare Parts" (Undersize Bearing) MAIN BEARING(0.25 U.S.)	124764-02130	2					

Fig.8 PISTON & CONNECTING ROD

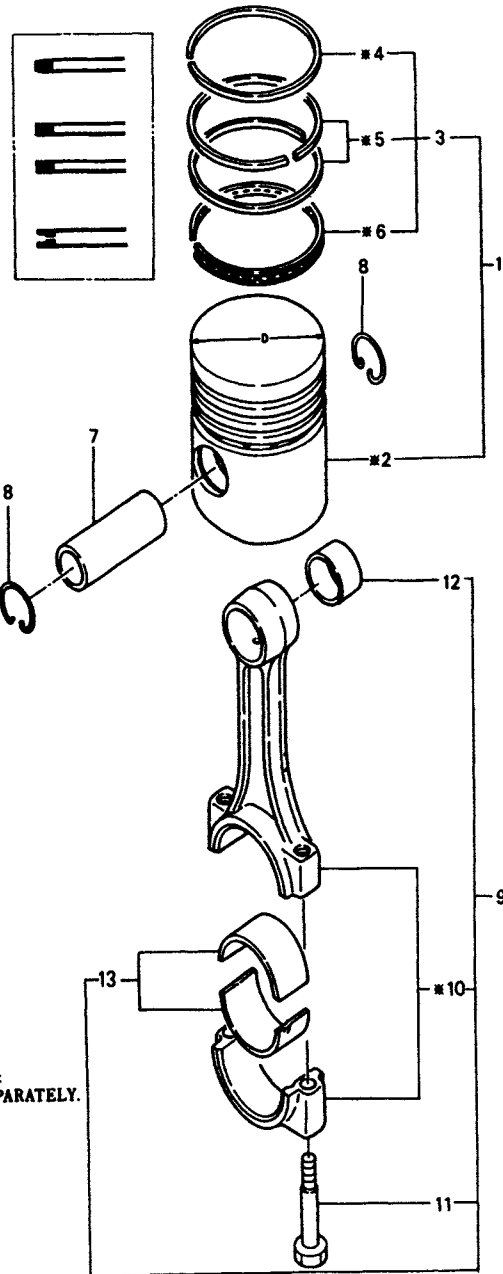

MARK PARTS:  
NOT SOLD SEPARATELY.

Nov., 1981

Fig. 8 PISTON & CONNECTING ROD

Refer. No.	Description	Part No.	Q'ty/Unit		Sales Unit	Interchangeability	Designation Mark	Remarks
			2TR 20A-YP (YM24)					
8- 1	PISTON w/RING	724768-22721	2					
8- 2	.PISTON	*	2		*			Order ASS'Y (124768-22021)
8- 3	.RING SET, piston	724763-22500	2		5			
8- 4	..RING, compression (No.1)	*	2		*			Order RING SET (124763-22110)
8- 5	..RING, compression (No.2 & 3)	*	4		*			Order RING SET (124763-22100)
8- 6	..RING, oil control	*	2		*			Order RING SET (124763-22900)
8- 7	PIN, piston 30d-73L	104600-22300	2					
8- 8	CIRCLIP, piston pin 32d	104600-22400	4		10			
8- 9	ROD ASS'Y, connecting	724450-23100	2					
8- 10	.ROD, connecting	*	2		*			Order ASS'Y (124450-23010)
8- 11	.BOLT, connecting rod	124450-23200	2		10			
8- 12	.BUSH, piston pin	124450-23100	2					
8- 13	.BEARING, crank pin	124450-23300	2					
	*Exclusive Spare Parts* (Undersize Bearing)							
8- 13	BEARING(0.25 U.S.), crank pin	124450-23350	2					

Nov., 1981

Nov., 1981

Fig.9 LUBRICATING OIL SYSTEM

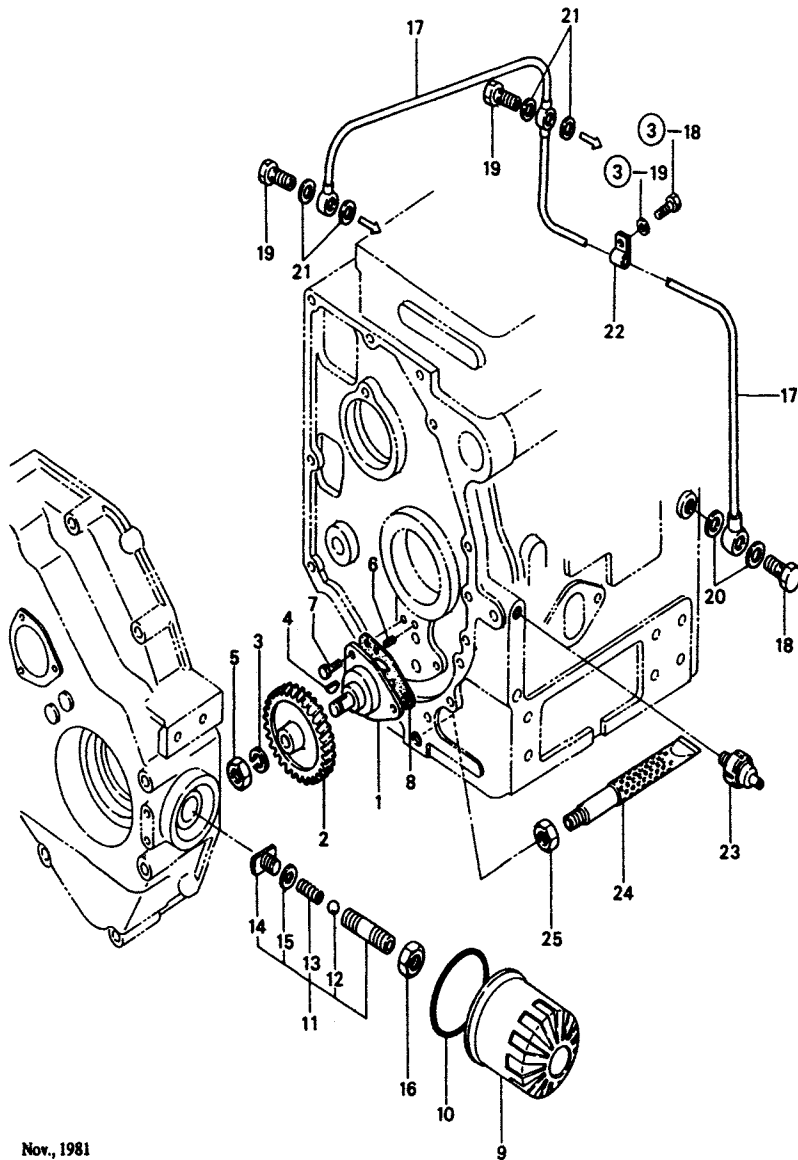

Nov., 1981

Fig. 9 LUBRICATING OIL SYSTEM

Refer. No.	Description	Part No.	Q'ty/Unit		Sales Unit	Interchangeability	Discharge Unit	Remarks
			JTR 26A-YP (7M24)					
9- 1	PUMP ASS'Y, lub. oil	724790-32100	1					
9- 2	.GEAR, lub. oil pump driving	121390-32200	1					
9- 3	.SPRING WASHER 8	22217-080000	1		10			
9- 4	.WOODRUFF KEY 3x10	22522-030100	1		10			
9- 5	.NUT M8	26716-080002	1		10			
9- 6	SPRING PIN 4x12	22351-040012	1		10			For pump body.
9- 7	BOLT M6x22	26116-060222	3		10			
9- 8	PACKING, lub. oil pump	124450-32020	1		10			
9- 9	STRAINER, lub. oil 80d-120L	124550-35110	1					
9- 10	O-RING, strainer	124450-35110	1		10			
9- 11	VALVE ASS'Y, control	121250-35300	1					
9- 12	.BALL 5/16	24190-100001	1		10			
9- 13	.SPRING, valve	121250-35320	1		10			
9- 14	.RETAINER, spring	121250-35330	1					
9- 15	.SHIM 8d	121250-35340	1		10			
9- 16	LOCK NUT M20	124450-35350	1		10			
9- 17	PIPE, lub. oil	124465-39200	1					
9- 18	BOLT 10, pipe joint	124160-39140	1		10			
9- 19	BOLT 8, pipe joint	124550-59820	2		10			
9- 20	PACKING 10	23414-100000	2		10			
9- 21	PACKING 8	23414-080000	4		10			
9- 22	CLAMP	124450-39240	1					
9- 23	SENDER, oil pressure	121252-39450	1					
9- 24	PIPE, lub. oil intake	124450-35060	1					
9- 25	LOCK NUT PFL/4	124450-35070	1		10			

Nov., 1981

Nov., 1981

Fig. 10 COOLING WATER SYSTEM

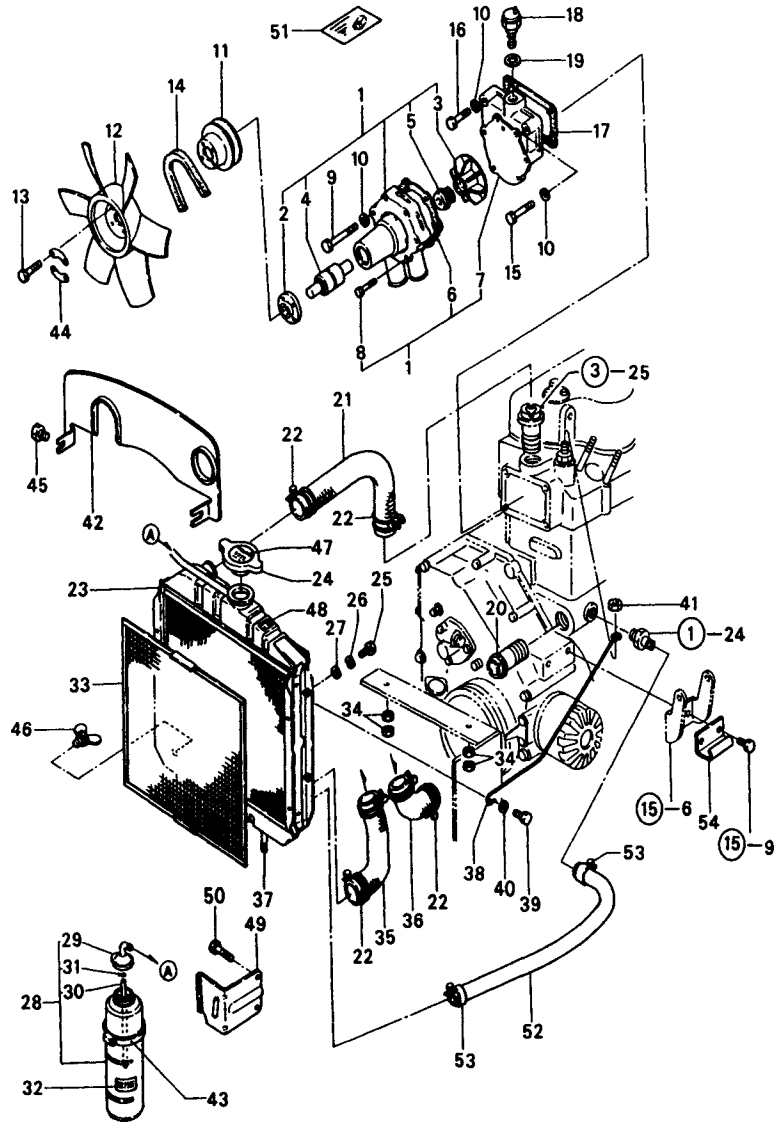

Nov., 1981

Fig. 10 COOLING WATER SYSTEM

Refer. No.	Description	Part No.	Qty/Unit		Sales Unit	Interchangeability	Designation Mark	Remarks
			17A 20A-YP (YM24)					
10- 1	PUMP ASS'Y, cooling water	124768-42011	1					
10- 2	.FLANGE, V-pulley	124768-42261	1					
10- 3	.IMPELLER	70d 121252-42200	1					
10- 4	.SHAFT, impeller	121252-42240	1					
10- 5	.SEAL, mechanical	121450-42310	1					
10- 6	.PACKING, c.w.pump	124750-42051	1		10			
10- 7	.MOUNT, c.w.pump	121250-42121	1					
10- 8	.BOLT M6x40	26116-060402	4		10			
10- 9	BOLT M8x70	26116-080702	2		10			
10- 10	WASHER 8	22117-080000	3		10			
10- 11	V-PULLEY	124768-42351	1					
10- 12	FAN	320d 124768-44740	1					
10- 13	BOLT M6x20	26116-060202	4		10			
10- 14	V-BELT(A38 inch)	124756-42290	1					
10- 15	BOLT M8x45	26116-080452	1		10			Pump mount. & belt adjuster set-tightening
10- 16	BOLT M8x40	26116-080402	1		10			
10- 17	PACKING, pump mount.	124450-44410	1		10			
10- 18	SENDER, temperature	121250-44901	1					
10- 19	PACKING 16	124465-44950	1		10			
10- 20	JOINT, c.w.pipe	124160-49480	1					
10- 21	PIPE(A), cooling water (cyl. - radiator)	124768-49010	1					
10- 22	CLAMP 38	23010-038000	6		10			

Nov., 1981

Nov., 1981



Fig. 10 COOLING WATER SYSTEM

Refer. No.	Description	Part No.	Qty/Unit		Sales Unit	Interchangeability	Designation Mark	Remarks
			2TR 20A-YP (FM241)					
10- 23	RADIATOR	124767-44500	1					
10- 24	.CAP, radiator	124450-44590	1					
10- 25	.BOLT M8x16	26116-080162	4		10			
10- 26	.SPRING WASHER 8	22217-080000	4		10			
10- 27	.WASHER 8	22117-080000	4		10			
10- 28	SUB-TANK ASS'Y, radiator	121252-44510	1					
10- 29	.CAP, sub-tank	121450-44530	1					
10- 30	.PIPE 7x230	23061-070230	1		10			
10- 31	.CLAMP, c.w. overflow pipe	124450-44560	1					
10- 32	LABEL, sub-tank	124742-44810	1		10			
10- 33	SCREEN, radiator	124767-44580	1					
10- 34	LOCK NUT M8	26756-080002	4		10			
10- 35	PIPE(B), cooling water (radiator - pump)	121150-49020	1					
10- 36	PIPE(C), cooling water (pump - cyl.)	121250-49030	1					
10- 37	STUD M8x48	124460-44850	2		10			
10- 38	STAY, radiator	124460-44600	1					
10- 39	BOLT M6x20	26116-060202	1		10			
10- 40	WASHER 6	22137-060000	4		10			
10- 41	LOCK NUT M15, radiator stay	124450-44610	1		10			
10- 42	PLATE, shelter	124768-44690	1					
10- 43	CLAMP, sub-tank	121750-44550	1					
10- 44	WASHER, fan	124768-44750	2					
10- 45	BOLT M6x12	26116-060122	3		10			
10- 46	COCK w/PACKING, radiator drain	124550-44690	1		10			

Nov., 1981

- 31 -

Nov., 1981

Fig. 10 COOLING WATER SYSTEM

Refer. No.	Description	Part No.	Qty/Unit		Sales Unit	Interchangeability	Designation Mark	Remarks
			2TR 20A-YP (FM241)					
10- 47	LABEL, radiator	124742-44800	1		10			
10- 48	LABEL, anti-freeze	124742-44920	1		10			
10- 49	BRACKET, sub-tank	124767-44600	1					
10- 50	BOLT M8x12	26116-080122	2		10			
10- 51	LABEL, drain caution	124742-07150	1		10			
10- 52	PIPE, drain	121250-49160	1					
10- 53	CLAMP 12	124766-59050	2		10			
10- 54	RETAINER, pipe	124764-49200	1		10			

Nov., 1981

- 32 -

Nov., 1981

Fig. 11 FUEL INJECTION PUMP

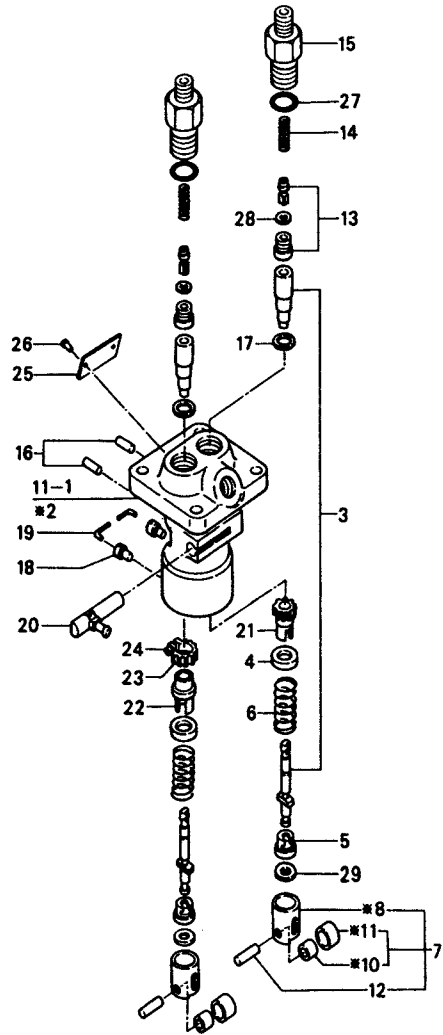

\*MARK PARTS: NOT SOLD SEPARATELY.

Fig. 11 FUEL INJECTION PUMP

Refer. No.	Description	Part No.	Q'ty/Unit		Sales Unit	Interchangeability	Discharge Mark	Remarks
			2TR 26A-7P (7M241)					
11- 1	PUMP ASS'Y, fuel injection	724761-51701	1					
11- 2	.BODY, f.i.pump	*	1		*			Order ASS'Y (124550-51011)
11- 3	.PLUNGER w/BARREL	124240-51100	2					
11- 4	.RETAINER, plunger spring	174307-51170	2					
11- 5	.RETAINER, plunger spring	174307-51181	2		10			
11- 6	.SPRING, plunger	174307-51190	2		10			
11- 7	.GUIDE ASS'Y, plunger	724550-51520	2					
11- 8	..GUIDE, plunger	*	2		*			Order ASS'Y (124550-51200)
11- 9	..ROLLER ASS'Y, plunger guide	711100-51540	2					
11- 10	...ROLLER, plunger guide (inner)	*	2		*			Order ASS'Y (111100-51210)
11- 11	...ROLLER, plunger guide (outer)	*	2		*			Order ASS'Y (111100-51220)
11- 12	..PIN, plunger guide roller	174100-54120	2		10			
11- 13	.VALVE, delivery	124550-51301	2		10			
11- 14	.SPRING, delivery valve	124550-51320	2		10			
11- 15	.HOLDER, delivery valve	124550-51341	2					
11- 16	.PIN, plunger barrel	174307-51250	2		10			
11- 17	.PACKING, plunger barrel	174307-51270	2		10			
11- 18	.STOPPER, plunger guide	174307-51450	2		10			
11- 19	.PIN, lock screw	174307-51460	2		10			
11- 20	.RACK ASS'Y, fuel control	724240-51530	1					
11- 21	.PINION(A), fuel control	174307-51510	1					
1								
11- 22	.SLEEVE, fuel control pinion(B)	174307-51550	1					

Fig. 11 FUEL INJECTION PUMP

Refer. No.	Description	Part No.	Qty/Unit		Sales Unit	Interchangeability	Designation Mark	Remarks
			1TR 20A-VP (7M241)					
11- 23	.PINION(B), fuel control	774307-51490	1					
11- 24	.LOCK SCREW, fuel control	122117-51560	1		10			
11- 25	.LABEL, fuel injection pump	*	1		*			Not sold (124761-51920)
11- 26	.RIVET 2.5x5	124220-51890	2		10			
11- 27	.O-RING, holder	124550-51370	2		10			
11- 28	.PACKING, delivery valve 12d-0.5t	124550-51350	2		10			
11- 29	.SHIM 19d	174307-51700	2		10			

Fig.12 FUEL INJECTION VALVE

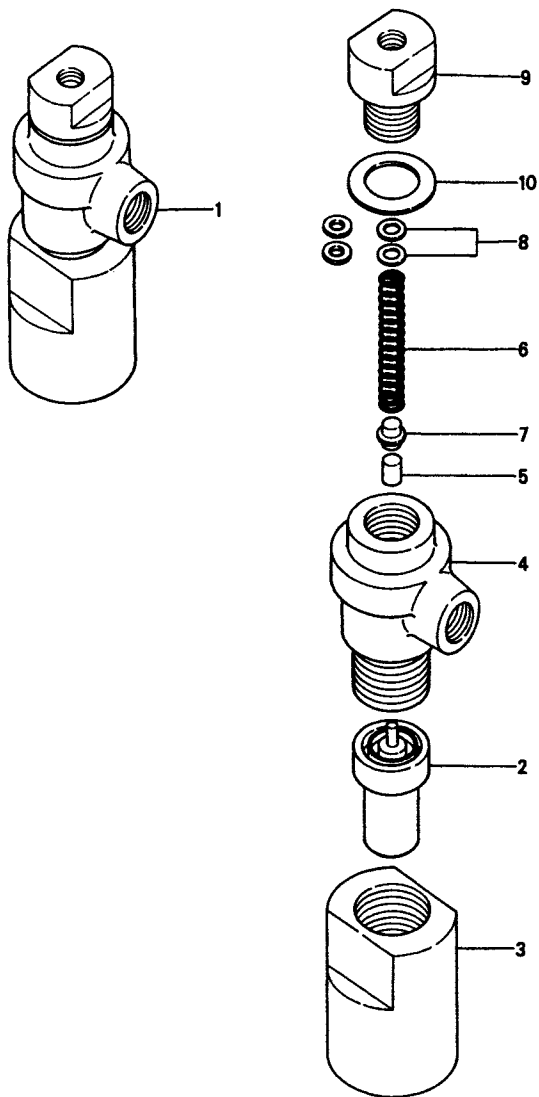

Nov., 1981

Fig. 12 FUEL INJECTION VALVE

Refer. No.	Description	Part No.	Q'ty/Unit		Sales Unit	Interchange-ability	Designchange Mark	Remarks
			STR	30A-VP (VM34B)				
12- 1	VALVE ASS'Y, fuel injection	724770-53100	2					
12- 2	.VALVE w/CASE	124770-53000	2		10			
12- 3	.HOLDER, valve	104900-53080	2					
12- 4	.BODY, f.i.valve	103854-53100	2					
12- 5	.SPINDLE, inter	113200-53110	2		10			
12- 6	.SPRING, valve	103854-53120	2		10			
12- 7	.SHOE, valve spring	113200-53120	2		10			
12- 8	.SHIM SET 11.5d-0.5t	110250-53150	2		10			
12- 9	.HOLDER, valve spring	103854-53180	2					
12- 10	.PACKING, holder	172100-53200	2		10			

Nov., 1981

Nov., 1981

Fig. 13 FUEL OIL SYSTEM

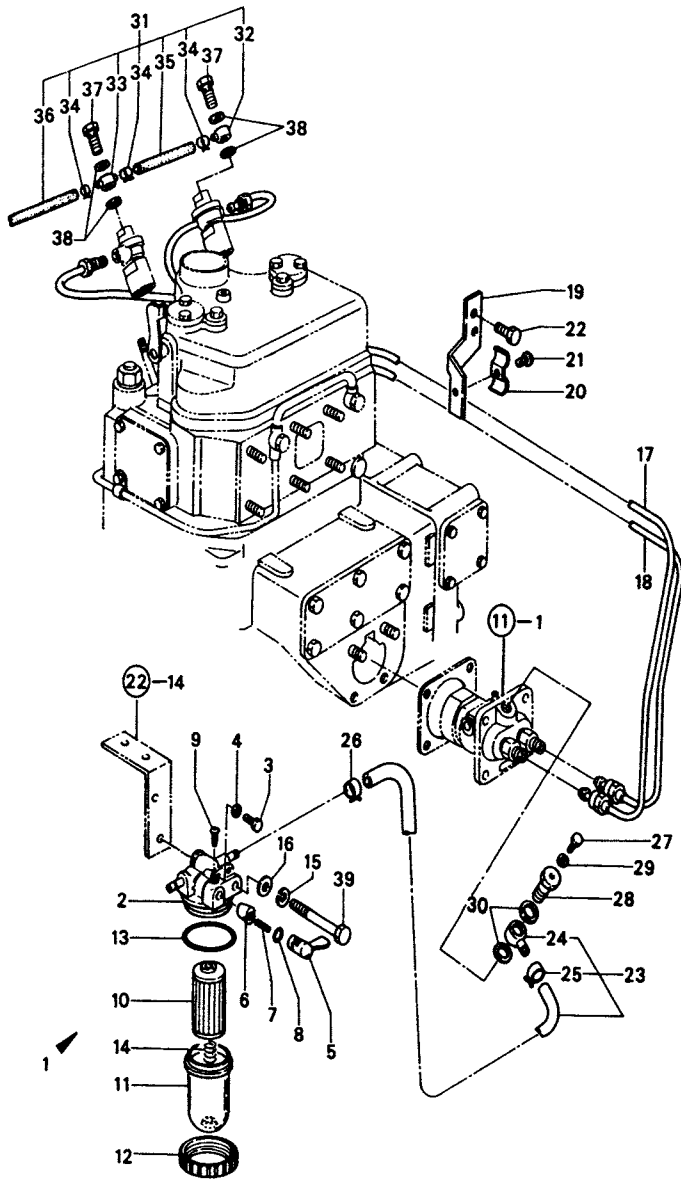

Nov., 1981

Fig. 13 FUEL OIL SYSTEM

Refer. No.	Description	Part No.	Q'ty/Unit		Sales Unit	Interchangeability	Designchange Mark	Remarks
			JTR 20A-YF (FM241)					
13- 1	STRAINER ASS'Y, fuel	121454-55600	1					
13- 2	.COCK ASS'Y, fuel	721257-55540	1					
13- 3	..PLUG M6, air vent	101720-55750	2		10			
13- 4	..PACKING 6	23418-060000	2		10			For plug
13- 5	..HANDLE, fuel cock	104200-55341	1					
13- 6	..VALVE, taper	104200-55321	1					
13- 7	..SPRING, valve	104200-55330	1					
13- 8	..O-RING 10A-P	24311-240100	1		10			For handle
13- 9	..LOCK SCREW, handle	104200-55750	1		10			
13- 10	.ELEMENT, fuel strainer 33d-90L	124550-55700	1		10			
13- 11	.BOWL, fuel strainer	121254-55510	1					
13- 12	.RETAINER, bowl	110250-55610	1					
13- 13	.O-RING, bowl 50.7d	102103-55520	1		10			
13- 14	.SPRING	121250-55620	1					
13- 15	SPRING WASHER 8	22217-080000	1		10			
13- 16	WASHER 8	22117-080000	1		10			For Strainer
13- 17	PIPE, f.i., No.1 cylinder	124465-59800	1					
13- 18	PIPE, f.i., No.2 cylinder	124465-59810	1					
13- 19	CLAMP(A), fuel injection pipe	124756-59850	1					
13- 20	CLAMP(B), fuel injection pipe	124450-59860	1					
13- 21	SCREW M6x8	26557-060082	1		10			
13- 22	BOLT M6x10	26116-060102	2		10			

Nov., 1981

Nov., 1981

Fig. 13 FUEL OIL SYSTEM

Refer. No.	Description	Part No.	Qty/Unit		Sales Unit	Interchangeability	Designation Mark	Remarks
			3TR 28A-YP (7M24)					
13- 23	PIPE, fuel oil (strainer-injection pump)	121422-59010	1					
13- 24	.JOINT 12, pipe	124250-59260	1		10			
13- 25	.CLAMP 12	124766-59050	1		10			
13- 26	CLAMP 12	124766-59050	1		10			
13- 27	PLUG 6, air vent	124060-59380	1		10			
13- 28	BOLT 12, pipe joint	124060-59391	1		10			
13- 29	SEAL WASHER 6	43400-500390	1		10			
13- 30	PACKING 12	104200-59170	2		10			
13- 31	PIPE, fuel return	124465-59500	1		10			
13- 32	.JOINT 8, pipe	124550-59030	1		10			
13- 33	.JOINT 8, pipe	124550-59090	1		10			
13- 34	.CLAMP 8	124066-59100	3		10			
13- 35	.PIPE, fuel return	121250-59550	1		10			
13- 36	.PIPE, fuel return	121250-59560	1		10			
13- 37	BOLT 8, pipe joint	101147-59810	2		10			
13- 38	PACKING 8	23414-080012	4		10			
13- 39	BOLT M8x70	26116-080702	1		10			For Strainer

Fig. 14 GOVERNOR SYSTEM

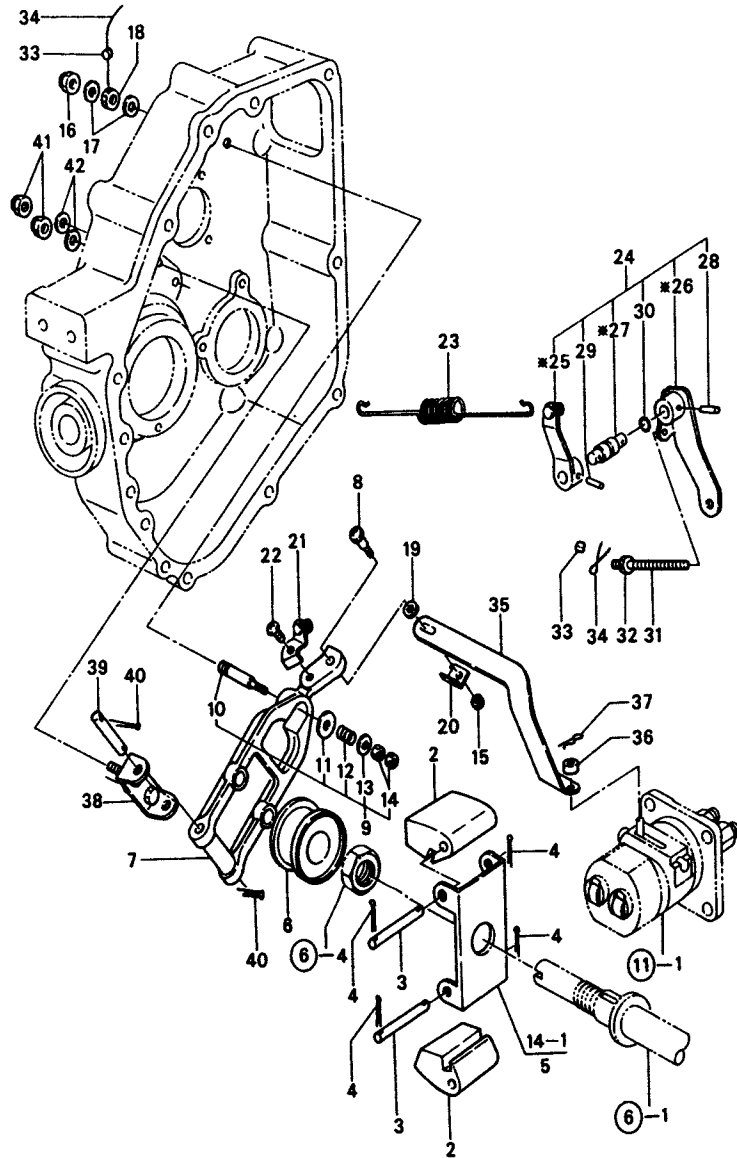

\* MARK PARTS: NOT SOLD SEPARATELY.

Nov., 1981

Fig. 14 GOVERNOR SYSTEM

Refer. No.	Description	Part No.	Q'ty/Unit		Sales Unit	Interchangeability	Designation Mark	Remarks
			1TR 26A-YP (YM341)					
14- 1	SUPPORT ASS'Y, governor weight	724450-61520	1					
14- 2	.WEIGHT, governor	124450-61200	2					
14- 3	.PIN, weight 6d-51L	124450-61220	2		10			
14- 4	.COTTER PIN 2x20	22417-200200	4		10			
14- 5	.SUPPORT, governor weight	124450-61110	1					
14- 6	SLEEVE, governor	121250-61600	1					
14- 7	LEVER w/BALL, governor	124460-66611	1					
14- 8	SCREW, governor link connect.	124450-66411	1		10			
14- 9	CONTROLLER ASS'Y, injection	124768-66800	1					
14- 10	.SHAFT, injection control	124450-66822	1					
14- 11	.SHOE(A), controller spring	124450-66850	1		10			
14- 12	.SPRING, controller	124768-66810	1		10			
14- 13	.WASHER(B), spring	124460-66850	1		10			
14- 14	.LOCK NUT M5	26756-050002	2		10			
14- 15	LOCK NUT M5	26756-050002	1		10			
14- 16	CAP NUT M8	26667-080002	1		10			
14- 17	SEAL WASHER 8	43400-500410	2		10			
14- 18	LOCK NUT M8	124772-66890	1		10			
14- 19	SPACER, governor link	124450-66430	1		10			
14- 20	LOCK WASHER, governor link	124460-66440	1		10			
14- 21	FITTINGS, regulator spring	121120-66100	1					
14- 22	SCREW M6x8	26557-060082	1		10			For Regulator spring
14- 23	SPRING, regulator	124768-66011	1		10			

Nov., 1981

Nov., 1981

Fig. 14 GOVERNOR SYSTEM

Refer. No.	Description	Part No.	Qty/Unit		Sales Unit	Interchangeability	Designchange Mark	Remarks
			2TR 20A-YP (7/62+0)					
14- 24	LEVER ASS'Y, regulator	121120-66000	1					
14- 25	.LEVER, regulator	*	1		*			Order ASS'Y (121120-66080)
14- 26	.HANDLE, regulator	*	1		*			Order ASS'Y (121422-66050)
14- 27	.SHAFT, regulator handle	*	1		*			Order ASS'Y (124450-66040)
14- 28	.TAPER PIN 3x18	22322-030180	1		10			For handle
14- 29	.TAPER PIN 3x16	22322-030160	1		10			For lever
14- 30	.O-RING 7-P	24311-000070	1		10			
14- 31	BOLT, adjusting	124550-66420	1		10			
14- 32	LOCK NUT M6, adjusting bolt	124550-66370	1		10			
14- 33	LEAD, sealing	135210-61090	2		10			
14- 34	WIRE 1.0	22451-100000	2		10			
14- 35	LINK, governor	124465-66400	1					
14- 36	SPACER, governor link	124450-66420	1		10			
14- 37	SNAP PIN 6	22360-060000	1		10			
14- 38	SUPPORT, governor lever	124450-66510	1					
14- 39	PIN, governor lever	124450-66550	1		10			
14- 40	COTTER PIN 2x20	22417-200200	2		10			
14- 41	CAP NUT M6	26657-060002	2		10			
14- 42	SEAL WASHER 6	43400-500400	2		10			



Fig.15 ELECTRIC STARTING SYSTEM

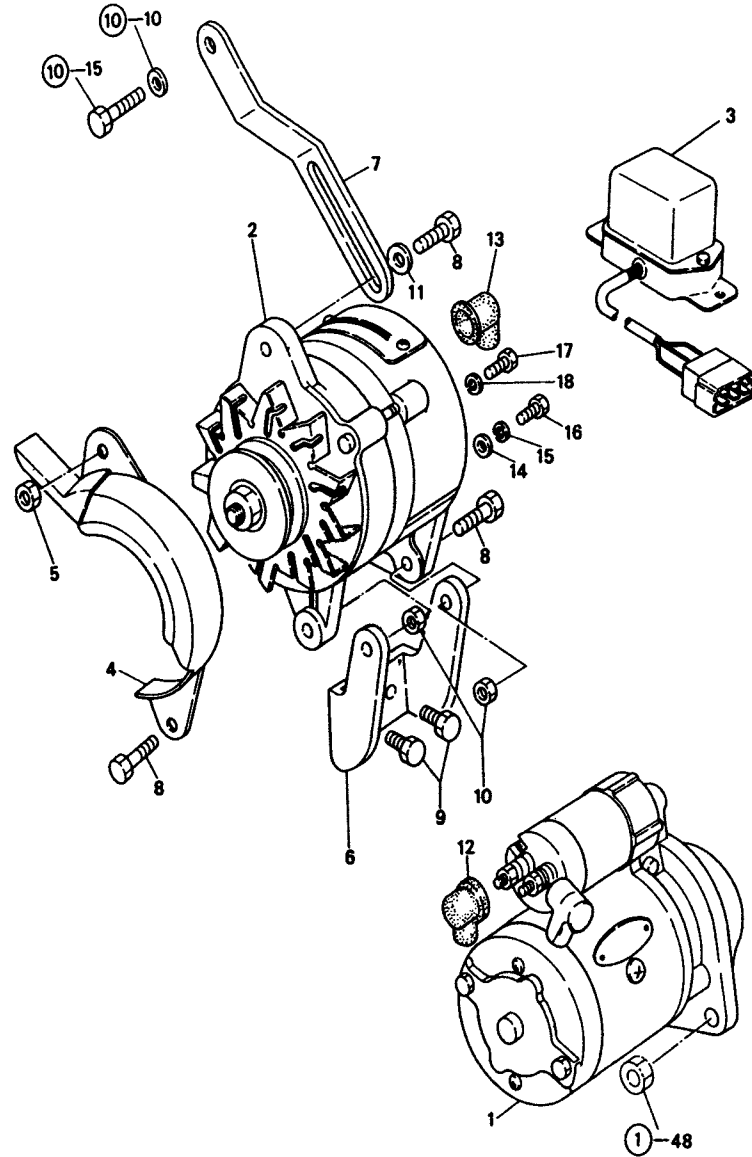
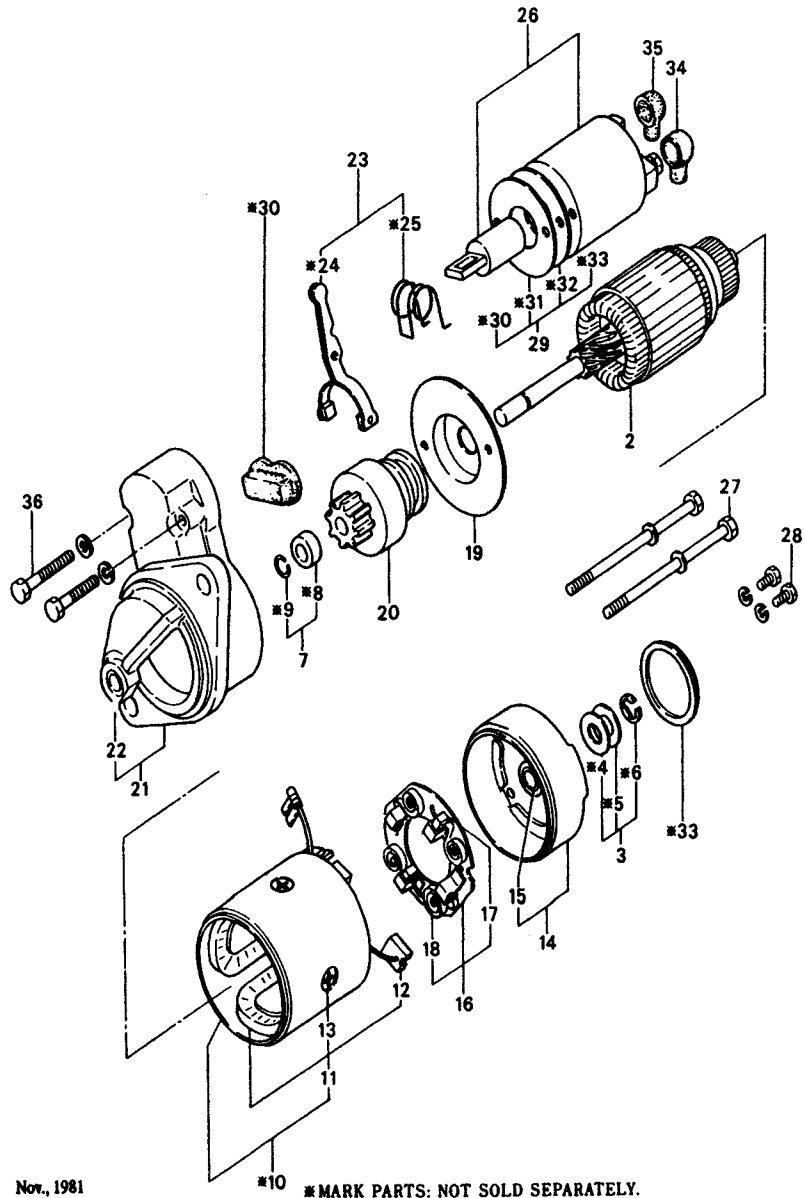

Fig. 15 ELECTRIC STARTING SYSTEM

Refer. No.	Description	Part No.	Qty/Unit		Sales Unit	Interchangeability	Discharge Mark	Remarks
			2TR 20A-YP (M241)					
15- 1	STARTER (12V-1.3kW)	124450-77010	1					(S114-146)
15- 2	GENERATOR, w/coupler	124756-77210	1					(LT115-52)
15- 3	REGULATOR	124550-77710	1					
15- 4	COVER, generator	121250-77210	1					
15- 5	LOCK NUT M8	26756-080002	1		10			
15- 6	BRACKET, generator	124450-77250	1					
15- 7	ADJUSTER, belt	124465-77330	1					
15- 8	BOLT M8x30	26116-080302	3		10			For Generator
15- 9	BOLT M8x18	26116-080182	2		10			For Generator bracket
15- 10	NUT M8	26716-080002	2		10			For Generator
15- 11	WASHER 8	22137-080000	1		10			For adjuster
15- 12	COVER, B-terminal	124550-77030	1		10			
15- 13	CAP, A-terminal	124756-77040	1		10			
15- 14	WASHER 5	22117-050000	1		10			A-terminal
15- 15	SPRING WASHER 5	22217-050000	1		10			A-terminal
15- 16	LOCK NUT M5	26756-050002	1		10			A-terminal
15- 17	BOLT M5x14	26116-050142	1		10			E-terminal
15- 18	SPRING WASHER 5	22217-050000	1		10			E-terminal

Fig. 16 STARTER (12V-1.3KW) TYPE S114-146



Nov., 1981

Fig. 16 STARTER (12V-1.3kW) TYPE S114-146

Refer. No.	Description	Part No.	Q'ty/Unit		Interchangeability	Designchange Mark	Remarks
			2TR 30A-YP (7M241)	Seal Unit			
16- 1	STARTER (S114-146)	124450-77010	1				
16- 2	.ARMATURE ASS'Y	X211491001	1				
16- 3	.THRUST WASHER KIT	X21148110	1	10			
16- 4	..THRUST WASHER (B)	*	3	*			Order KIT.
16- 5	..THRUST WASHER (C)	*	1	*			Order KIT.
16- 6	..E-RING	*	1	*			Order KIT.
16- 7	.STOPPER SET, pinion	X21147155	1				
16- 8	..STOPPER, pinion	*	1	*			Order SET.
16- 9	..CIRCLIP, pinion	*	1	*			Order SET.
16- 10	.YOKE ASS'Y	*	1	*			Not sold.
16- 11	..COIL ASS'Y, field	X211482001	1				
16- 12	...BRUSH(+)	X21145312	2	10			
16- 13	...SCREW, pole core	X21147215	4	10			
16- 14	.COVER ASS'Y, rear	X211423001	1				
16- 15	..BUSH, rear cover	X21145352	1				
16- 16	.HOLDER ASS'Y, brush	X21141360	1				
16- 17	..BRUSH(-)	X21145313	2	10			
16- 18	..SPRING, brush	X21144314	4	10			
16- 19	.PLATE, center	X21143454	1				
16- 20	.PINION ASS'Y	X211445002	1				
16- 21	.CASE ASS'Y, gear	X211486003	1				
16- 22	..BUSH, gear case	X21144661	1				
16- 23	.LEVER SET, shift	X21148652	1				
16- 24	..LEVER, shift	*	1	*			Order SET.
16- 25	..SPRING, torsion	*	1	*			Order SET.

Nov., 1981

Nov., 1981

Fig. 16 STARTER (12V-1.3 kW) TYPE S114-146

Refer. No.	Description	Part No.	Q'ty/Unit		Sales Unit	Interchange-ability	Designchange Mark	Remarks
			STR 30A-YP (7M241)					
16- 26	.SWITCH ASS'Y, magnetic	X211457001	1					
16--27	.THROUGH BOLT	X21146815	2		10			
16- 28	.SCREW M4x12	26557-040122	2		10			
16- 29	.COVER KIT, dust	X21143963	1		10			
16- 30	..COVER(A), dust	*	1		*			Order KIT.
16- 31	..COVER(B), dust	*	1		*			Order KIT.
16- 32	..COVER(C), dust	*	1		*			Order KIT.
16- 33	..COVER(D), dust	*	1		*			Order KIT.
16- 34	.CAP	X21144858	1		10			
16- 35	.CAP	X21145858	1		10			
16- 36	.BOLT M6x32	26116-060322	2		10			

Fig.17 AC GENERATOR (12V-15A) TYPE LT115-52

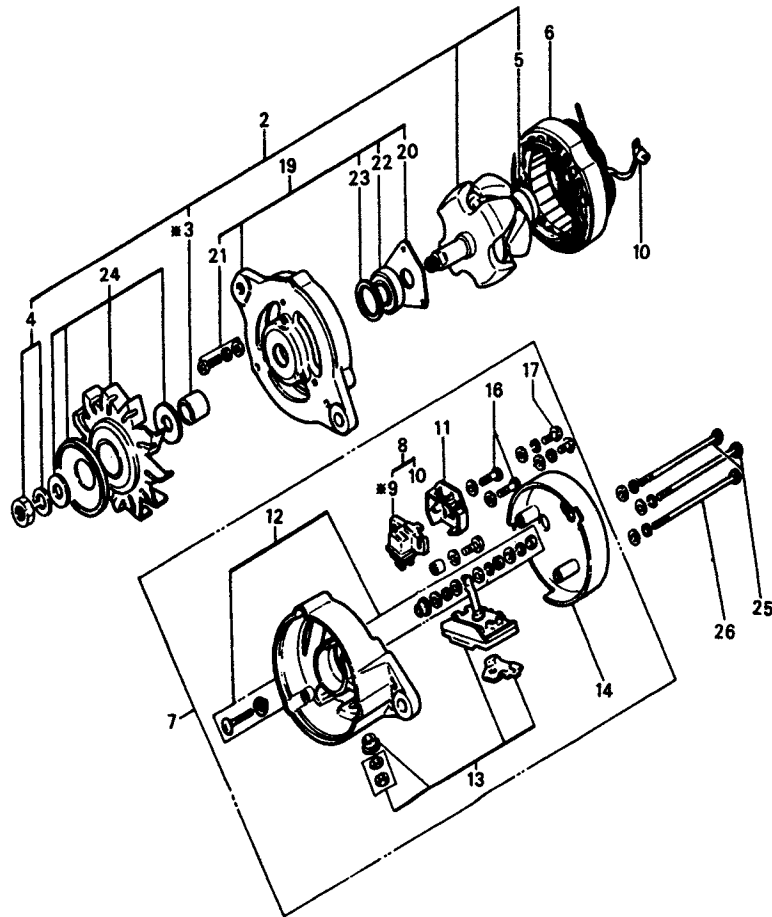

Nov., 1981

\* MARK PARTS: NOT SOLD SEPARATELY.

Fig. 17 AC GENERATOR (12V-15A) TYPE LT115-52

Refer. No.	Description	Part No.	Q'ty/Unit		Sales Unit	Interchangeability	Designchange Mark	Remarks
			2YR 20A-YP (7M241)					
17- 1	GENERATOR, w/coupler	124756-77210	1					
17- 2	..ROTOR ASS'Y	XL1157100	1					
17- 3	..SPACER	*	1		*			Order ASS'Y
17- 4	..NUT ASS'Y, pulley	XB444001A	1					
17- 5	..BALL BEARING	X6201SD	1					
17- 6	..STATOR ASS'Y	XL135N2200	1					
17- 7	..COVER ASS'Y, rear	XL1156300	1					
17- 8	..BRUSH ASS'Y	XL135N1301	1					
17- 9	...HOLDER, brush	*	1		*			Order ASS'Y
17- 10	...N-TERMINAL	XL135N1302	1					
17- 11	..COVER, brush	XL135N1303	1					
17- 12	..BOLT ASS'Y, terminal	XL1255310A	1					
17- 13	..CONTROL UNIT	XL1256320	1					
17- 14	..COVER	XL1152803	1					
17- 15	..SPACER(E)	XL1151341	1					
17- 16	..SCREW M4x20	26557-040202	2		10			
17- 17	..SCREW M4x8	26557-040082	3		10			
17- 18	..BOLT M5x16	26117-050169	1		10			
17- 19	..COVER ASS'Y, front	XL1156400	1					
17- 20	..RETAINER, bearing	XL1201404	1					
17- 21	..SCREW M4x20	26557-040202	3		10			
17- 22	..BALL BEARING	X6202B	1					
17- 23	..RETAINER	XL1201403	1					
17- 24	..PULLEY ASS'Y	XL1151552	1					
17- 25	..THROUGH BOLT	XL1251801	2					
17- 26	..THROUGH BOLT	XL1251802	1					

Nov., 1981

Nov., 1981

Fig.18 THERMOSTART DEVICE

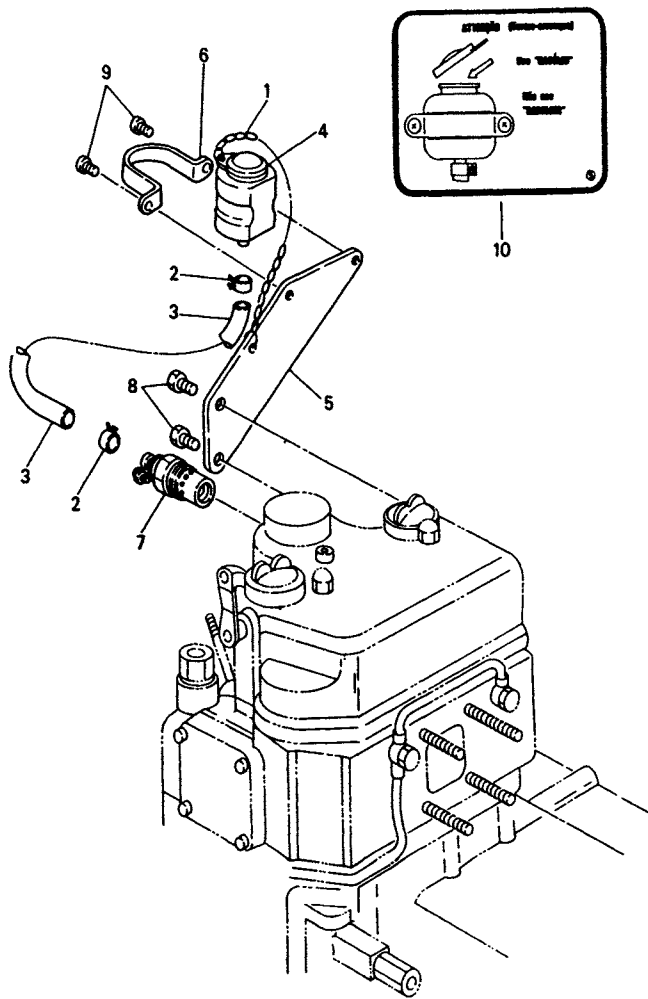

Fig. 18 THERMOSTART DEVICE

Refer. No.	Description	Part No.	Q'ty/Unit		Sales Unit	Interchange-ability	Designchange Mark	Remarks
			JTR 26A-YP (VM241)					
18- 1	CHAIN	101100-55060	1		10			
18- 2	CLAMP 10	124060-77680	2		10			
18- 3	PIPE	124460-77701	1		10			
18- 4	TANK, header	124460-77802	1					
18- 5	BRACKET, header tank	124460-77810	1					
18- 6	BRACE, header tank	124460-77820	1					
18- 7	PLUG, thermostart	121023-77910	1					
18- 8	BOLT M8x12	26116-080122	2		10			
18- 9	SCREW M6x8	26557-060082	2		10			
18- 10	LABEL, thermostart fuel	124742-77980	1		10			

Fig. 19 GASKET KIT (FOR ENGINE)

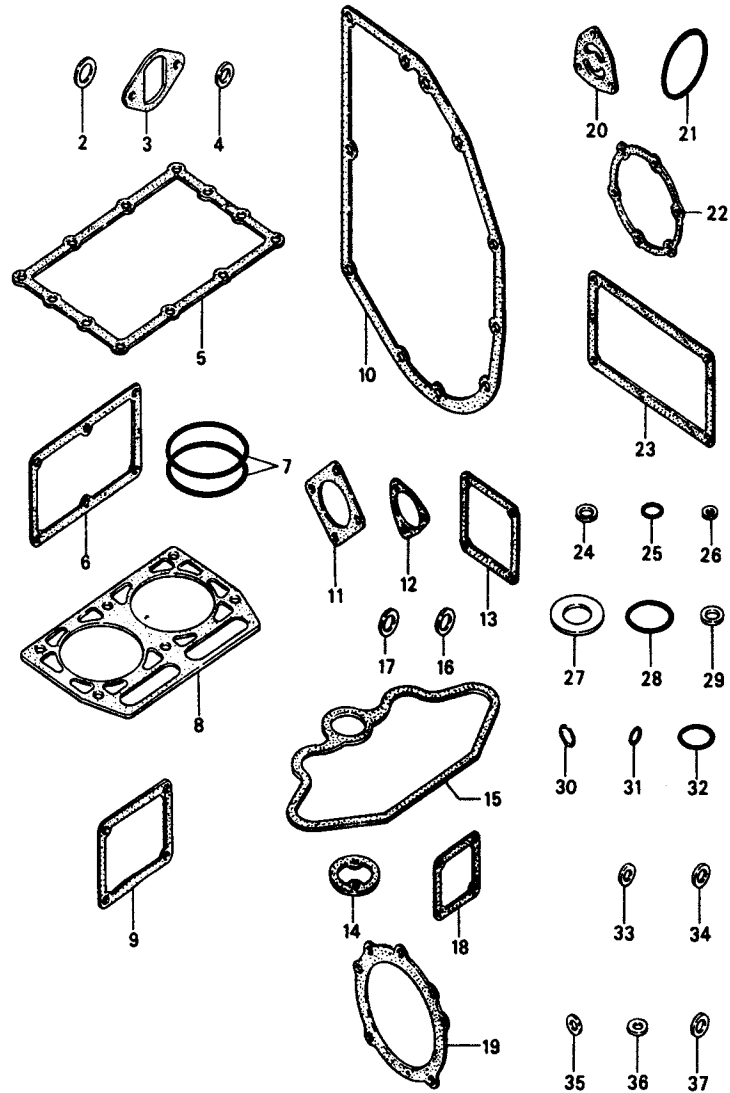

Fig. 19 GASKET KIT (FOR ENGINE)

Refer. No.	Description	Part No.	Q'ty/Unit		Sales Unit	Interchangeability	Designchange Mark	Remarks
			JTB 20A-YP (VM241)					
19- 1	GASKET KIT	724764-92600	1					
19- 2	.PACKING 10	121250-01990	1					(1-4)
19- 3	.PACKING, flange	124160-34844	1					(1-11)
19- 4	.PACKING 14	124450-01980	1					(1-15)
19- 5	.PACKING, oil pan	124465-01751	1					(1-30)
19- 6	.PACKING, f.i.pump room	124160-01863	1					(1-33)
19- 7	.PACKING, cyl. liner	124550-01300	4					(1-44)
19- 8	.GASKET, cyl. head	124763-01330	1					(1-45)
19- 9	.PACKING, cover	124160-01532	1					(2-4)
19- 10	.PACKING, gear housing	124450-01511	1					(2-18)
19- 11	.PACKING, hydraulic pump	124240-01882	1					(2-22)
19- 12	.PACKING, gear unit	124250-91412	1					(2-35)
19- 13	.PACKING, side cover	124450-11681	1					(3-16)
19- 14	.PACKING, adjust cover	124460-03663	2					(3-46)
19- 15	.PACKING, bonnet	124450-11310	1					(3-56)
19- 16	.PACKING, chamber	104900-11450	4					(3-59)
19- 17	.INSULATOR, heat	103854-11490	2					(3-60)
19- 18	.GASKET, silencer	124450-11900	2					(5-1)
19- 19	.PACKING, main brg. housing	124460-02150	1					(7-16)
19- 20	.PACKING, lub. oil pump	124450-32020	1					(9-8)
19- 21	.O-RING, strainer	124450-35110	1					(9-10)
19- 22	.PACKING, cooling water pump	124750-42051	1					(10-6)
19- 23	.PACKING, pump mount.	124450-44410	1					(10-17)
19- 24	.PACKING, plunger barrel	174307-51270	2					(11-17)
19- 25	.O-RING, holder	124550-51370	2					(11-27)
19- 26	.PACKING, delivery valve	124550-51350	2					(11-28)

Fig. 19 GASKET KIT (FOR ENGINE)

Refer. No.	Description	Part No.	Qty/Unit		Sales Unit	Interchangeability	Designchange Mark	Remarks
			2TR 20A-7P (7/12/81)					
19- 27	.PACKING, holder	172100-53200	2					(12-10)
19- 28	.O-RING, bowl 50.7d	102103-55520	1					(13-13)
19- 29	.PACKING 12	104200-59170	2					(13-30)
19- 30	.O-RING 7-P	24311-000070	2					(3-49) . (14-30)
19- 31	.O-RING 14-P	24311-000140	2					(1-29) . (3-55)
19- 32	.O-RING 35-G	24321-000350	1					(1-13)
19- 33	.SEAL WASHER 6	43400-500400	2					(14-42)
19- 34	.SEAL WASHER 8	43400-500410	4					(1-18) . (14-17)
19- 35	.PACKING 6	23414-060000	3					(2-38)
19- 36	.PACKING 8	23414-080000	13					(2-7) . (9-21) . (13-38)
19- 37	.PACKING 10	23414-100000	2					(9-20)

## **CHASSIS PARTS**

Type **YM241**

**YM241D**





Fig. 20 UNDERSLUNG EXHAUST SILENCER

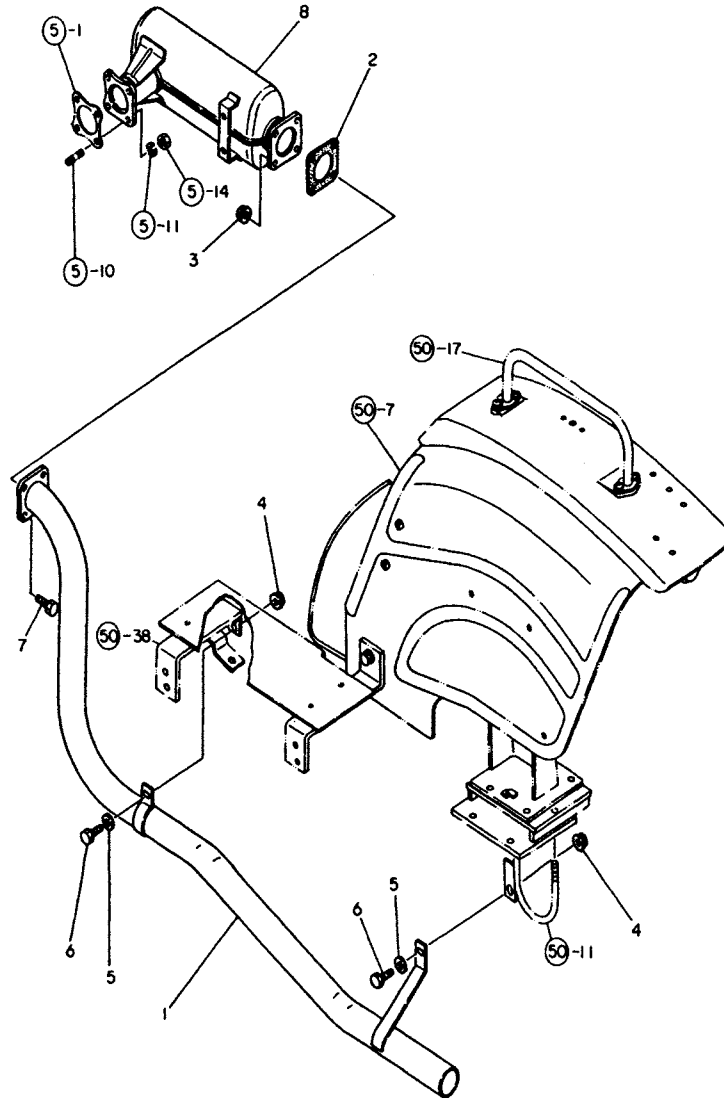

Fig. 20 UNDERSLUNG EXHAUST SILENCER

Refer. No.	Description	Part No.	Q'ty/Unit		Sales Unit	Interchangeability	Designation Mark	Remarks
			YM241	YM241D				
20- 1	PIPE, exhaust	2-194242-03420	1	1				
20- 2	GASKET	121450-13200	1	1				
20- 3	NUT M8	194990-22050	4	4	10			
20- 4	NUT M8	194990-22140	2	2	10.			
20- 5	WASHER 8	22137-080000	2	2	10			
20- 6	BOLT M8x25	26116-080252	2	2	10			
20- 7	BOLT M8x30	26116-080302	4	4	10			
20- 8	SILENCER, exhaust	2-124742-13500	1	1				

Fig. 21 THROTTLE

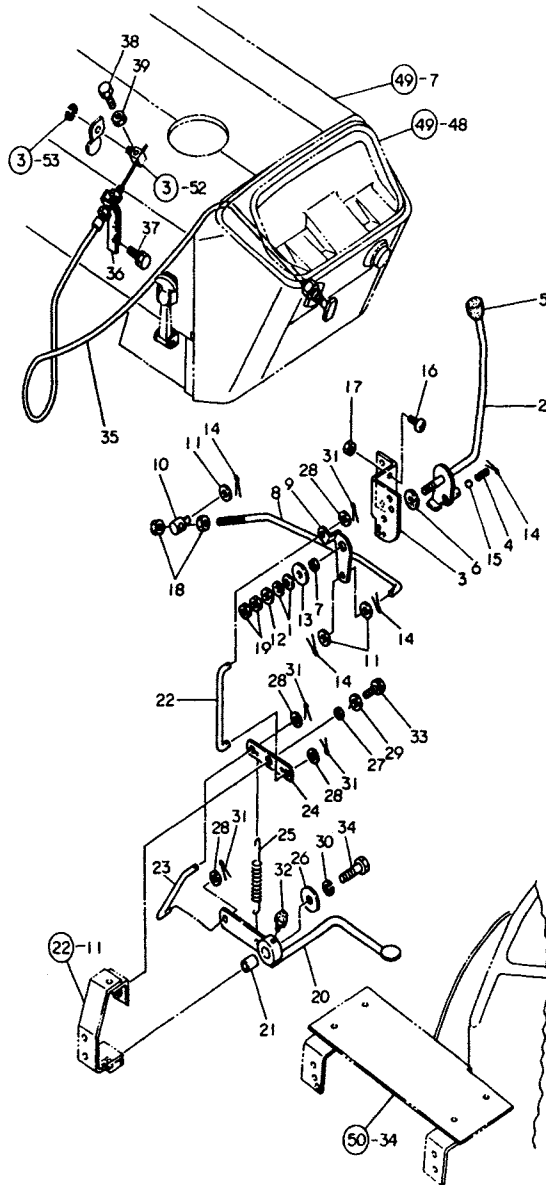

Fig. 21 THROTTLE

Refer. No.	Description	Part No.	Q'ty/Unit		Sales Unit	Interchangeability	Designchange Mark	Remarks
			YM241	YM241D				
21- 1	WASHER 10, spring	194740-00160	2	2	10			
21- 2	LEVER, throttle	194242-01110	1	1				
21- 3	BRACKET, throttle	194242-01140	1	1				
21- 4	SPRING, lock	194197-01160	1	1				
21- 5	KNOB, throttle lever	194150-01190	1	1				
21- 6	DISC 11x40x3, friction	194145-01260	1	1				
21- 7	SPACER 10x20x4	194150-01270	1	1				
21- 8	ROD, throttle link	194242-01320	1	1				
21- 9	LEVER, throttle link	194286-01350	1	1				
21- 10	ADJUSTER, throttle	194150-01370	1	1				
21- 11	WASHER 8	22137-080000	3	3	10			
21- 12	WASHER 10	22137-100000	1	1	10			
21- 13	WASHER 10	22157-100000	1	1	10			
21- 14	COTTER PIN 1.6x18	22417-160180	4	4	10			
21- 15	BALL 11/32	24190-110001	1	1	10			
21- 16	SCREW M6x12	26557-060122	2	2	10			
21- 17	NUT M6	26716-060002	2	2	10			
21- 18	NUT M8	26716-080002	2	2	10			
21- 19	NUT M10	26716-100002	2	2	10			
21- 20	PEDAL, throttle	X-194286-01411	1	1				
21- 21	BUSH 12x18x20	194286-01450	1	1				
21- 22	ROD(A), throttle pedal	194242-01440	1	1				
21- 23	ROD(B), throttle pedal	194242-01450	1	1				
21- 24	LINK, throttle pedal	194242-01460	1	1				
21- 25	SPRING, throttle	194750-04400	1	1				
21- 26	WASHER 13x36x4.5	194740-20251	1	1				

Fig. 21 THROTTLE

Refer. No.	Description	Part No.	Qty/Unit		Sales Unit	Interchangeability	Designchange Mark	Remarks
			YM241	YM241D				
21- 27	COLLAR 13.8x5	1E4060-44040	1	1				
21- 28	WASHER 8	22137-080000	4	4	10			
21- 29	WASHER 8	22157-080000	1	1	10			
21- 30	SPRING WASHER 12	22217-120000	1	1	10			
21- 31	COTTER PIN 1.6x18	22417-160180	4	4	10			
21- 32	GREASE NIPPLE M6F	24761-010000	1	1	10			
21- 33	BOLT M8x20	26013-080202	1	1	10			
21- 34	BOLT M12x45	26116-120452	1	1	10			
21- 35	CABLE, decompression	194167-01500	1	1				
21- 36	BRACKET, decomp. lever	194286-01550	1	1				
21- 37	BOLT M8x12	26013-080122	2	2	10			
21- 38	BOLT M5x14	26116-050142	1	1	10			
21- 39	LOCK NUT M5	26756-050002	1	1	10			

Fig. 22 FUEL TANK

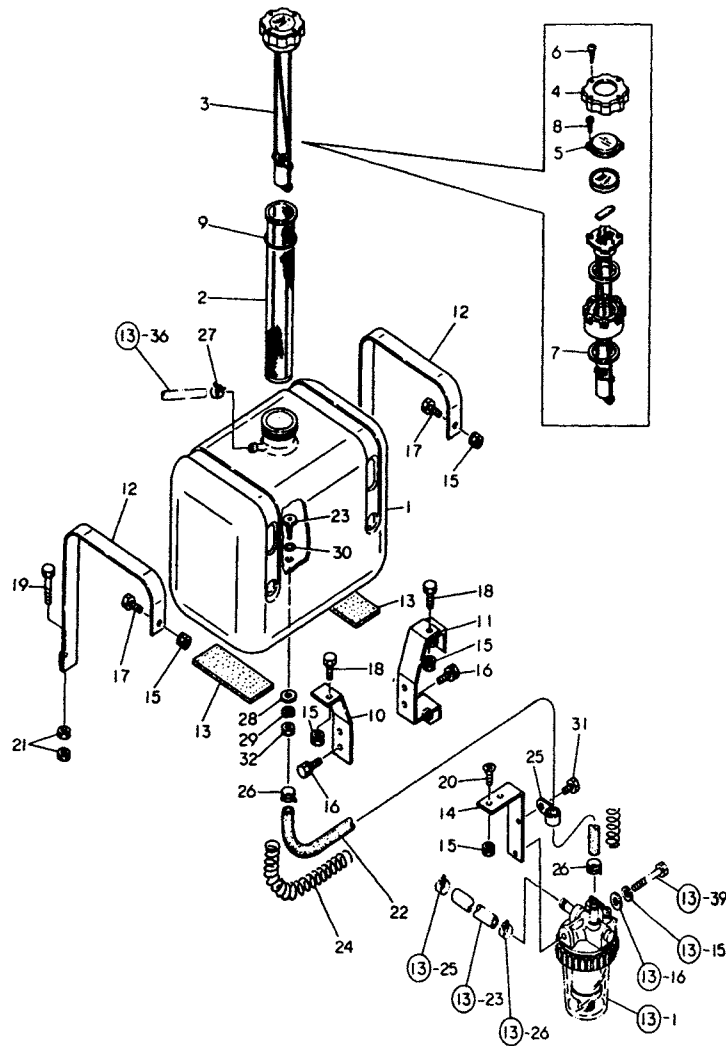

Fig. 22 FUEL TANK

Refer. No.	Description	Part No.	Q'ty/Unit		Sales Unit	Interchangeability	Designchange Mark	Remarks
			YM241	YM241D				
22- 1	TANK, fuel	194286-04110	1	1				
22- 2	STRAINER, fuel	194286-04140	1	1				
22- 3	CAP ASS'Y	194145-04302	1	1				
22- 4	.CAP (A)	194145-04311	1	1				
22- 5	.LENS	194145-04351	1	1				
22- 6	.SCREW M4x12	194145-04460	4	4	10			
22- 7	.PACKING, cap	194145-04521	1	1				
22- 8	.SCREW M3x6	26557-030062	2	2	10			
22- 9	O-RING 45-P	24311-000450	1	1	10			
22- 10	BRACKET(L), tank	X-194286-04220	1	1				
22- 11	BRACKET(R), tank	X-194242-04230	1	1				
22- 12	CLAMP, fuel tank	194310-04250	2	2				
22- 13	PACKING	194151-04260	2	2				
22- 14	STAY, water separator	X-194242-04300	1	1				
22- 15	NUT M8	194990-22050	6	6	10			
22- 16	BOLT M8x16	26013-080162	4	4	10			
22- 17	BOLT M8x16	26116-080162	2	2	10			
22- 18	BOLT M8x25	26116-080252	2	2	10			
22- 19	BOLT M8x50	26116-080502	2	2	10			
22- 20	SCREW M8x25	26577-080252	2	2	10			
22- 21	NUT M8	26716-080002	4	4	10			
22- 22	PIPE, fuel	194145-04720	1	1				
22- 23	JOINT, fuel outlet	194150-04750	1	1				
22- 24	SPRING, protect	171022-49520	1	1				
22- 25	CLAMP(B)	194440-51620	1	1				
22- 26	CLAMP 12	124766-59050	2	2	10			

Fig. 22 FUEL TANK

Refer. No.	Description	Part No.	Q'ty/Unit		Sales Unit	Interchangeability	Discharge Mark	Remarks
			YM241	YM241D				
22- 27	CLAMP 8	124066-59100	1	1	10			
22- 28	WASHER 10	22137-100000	1	1	10			
22- 29	SPRING WASHER 10	22217-100000	1	1	10			
22- 30	O-RING 12-P	24311-000120	1	1	10			
22- 31	BOLT M8x14	26116-080142	1	1	10			
22- 32	NUT M10	26716-100002	1	1	10			

Fig. 23 FRONT AXLE BRACKET [FOR MODEL YM241]

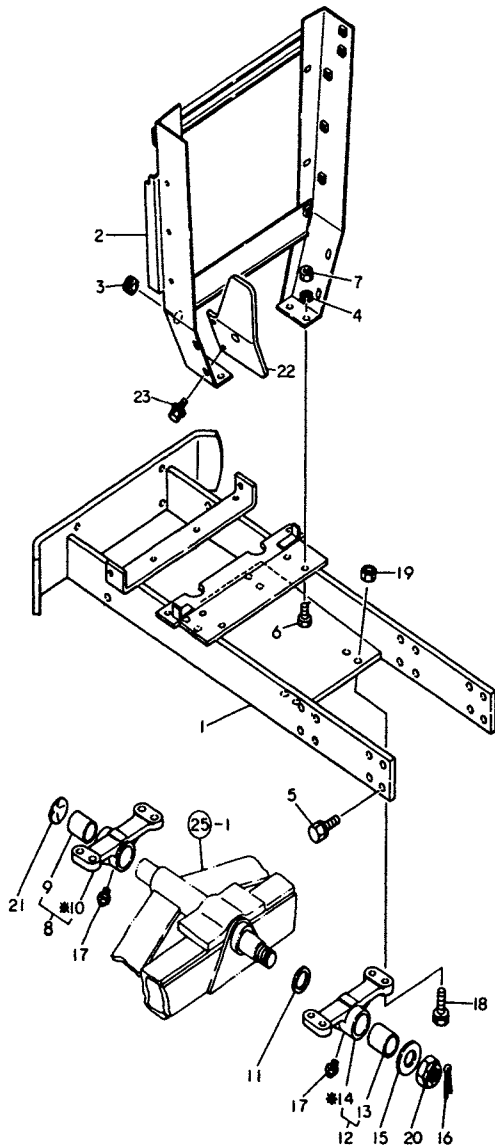

※ MARK PARTS: NOT SOLD SEPARATELY.

Fig. 23 FRONT AXLE BRACKET (FOR MODEL YM241)

Refer. No.	Description	Part No.	Qty/Unit		Sales Unit	Interchangeability	Designation Mark	Remarks
			YM241	YM241D				
23- 1	BRACKET, front axle	X-194286-11110	1					
23- 2	BRACKET, radiator	X-194286-11150	1					
23- 3	GROMMET 20	194162-58830	1					
23- 4	SPRING WASHER 10	22217-100000	4		10			
23- 5	BOLT M12x30	26013-120302	14		10			
23- 6	BOLT M10x20	26116-100202	4		10			
23- 7	NUT M10	26716-100002	4		10			
23- 8	BRACKET ASS'Y (F)	X-194286-13500	1					
23- 9	.BUSH 30x2x40	194080-11120	1					
23- 10	.BRACKET (F), center pin	*	1		*			Order ASS'Y (194286-13510)
23- 11	SHIM, center pin	194240-13520	1		10			
23- 12	BRACKET ASS'Y (R)	X-194286-13530	1					
23- 13	.BUSH 30x2x40	194080-11120	1					
23- 14	.BRACKET (R), center pin	*	1		*			Order ASS'Y (194286-13540)
23- 15	WASHER 27	22137-270000	1					
23- 16	COTTER PIN 4.5x60	22417-450600	1		10			
23- 17	GREASE NIPPLE M6F	24761-010000	2		10			
23- 18	BOLT M12x40	26013-120402	8		10			
23- 19	NUT M12	26716-120002	8		10			
23- 20	CASTLE NUT M27	26877-270002	1					
23- 21	PLUG 40	27233-400000	1		10			
23- 22	COVER (L), belt	194286-05110	1					
23- 23	BOLT M6x16	194155-05210	2		10			

Fig. 24 FRONT AXLE BRACKET (FOR MODEL YM241D)

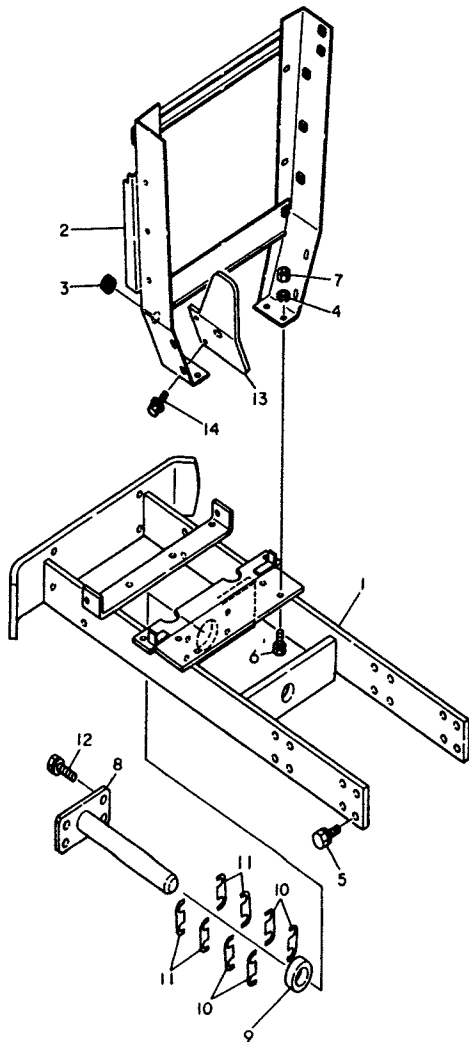
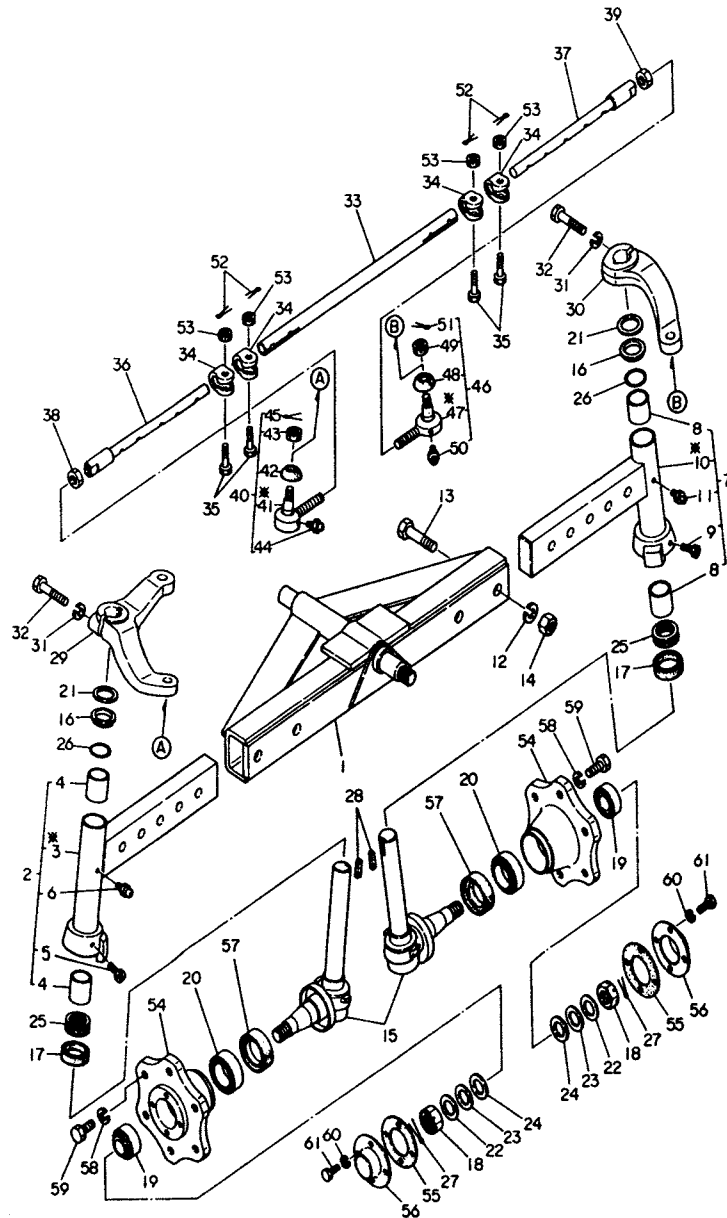

Fig. 24 FRONT AXLE BRACKET (FOR MODEL YM241D)

Refer. No.	Description	Part No.	Qty/Unit		Sales Unit	Interchangeability	Designation Mark	Remarks
			YM241	YM241D				
24- 1	BRACKET, front axle	X-194287-11110		1				
24- 2	BRACKET, radiator	X-194286-11150		1				
24- 3	GROMMET 20	194162-58830		1				
24- 4	SPRING WASHER 10	22217-100000		4	10			
24- 5	BOLT M12x30	26013-120302		14	10			
24- 6	BOLT M10x20	26116-100202		4	10			
24- 7	NUT M10	26716-100002		4	10			
24- 8	PIN, center	X-194311-11510		1				
24- 9	SPACER 30x55x18	194311-11520		1				
24- 10	SHIM t=0.5	194191-13232		-	10			} Selective
24- 11	SHIM t=0.25	194191-13240		-	10			
24- 12	BOLT M12x30	26013-120302		4	10			
24- 13	COVER(L), belt	194286-05110		1				
24- 14	BOLT M6x16	194155-05210		2	10			



Fig. 25 FRONT AXLE (FOR MODEL YM241)



\* MARK PARTS: NOT SOLD SEPARATELY.

Fig. 25 FRONT AXLE (FOR MODEL YM241)

Refer. No.	Description	Part No.	Q'ty/Unit		Sales Unit	Interchangeability	Designation Mark	Remarks
			YM241	YM241D				
25- 1	AXLE, front	X-194242-11210	1					
25- 2	EXTENSION ASS'Y(L)	X-194432-11300	1					
25- 3	.EXTENSION(L)	*	1		*			Order ASS'Y (194432-11310)
25- 4	.BUSH 30x34x32	194464-11340	2					
25- 5	.BOLT M6x5	194145-11350	1		10			
25- 6	.GREASE NIPPLE MT6x1	194151-11480	1		10			
25- 7	EXTENSION ASS'Y(R)	X-194432-11400	1					
25- 8	.BUSH 30x34x32	194464-11340	2					
25- 9	.BOLT M6x5	194145-11350	1		10			
25- 10	.EXTENSION(R)	*	1		*			Order ASS'Y (194432-11410)
25- 11	.GREASE NIPPLE MT6x1	194151-11480	1		10			
25- 12	SPRING WASHER 16	22217-160000	4		10			
25- 13	BOLT M16x65	26116-160652	4					
25- 14	NUT M16	26716-160002	4		10			
25- 15	SPINDLE	X-194145-11801	2					
25- 16	COVER, spindle upper	194145-11820	2					
25- 17	SEAL TC 38 52 9, oil	194145-11860	2					
25- 18	CASTLE NUT	194145-11870	2		10			
25- 19	ROLLER BEARING #30205	194145-11910	2					
25- 20	ROLLER BEARING #32007	194145-11920	2					
25- 21	SHIM, spindle	194145-11930	2		10			
25- 22	WASHER, front spindle t=3 (deviation 0 - -0.03)	194145-11970	-		10			Selective
25- 23	WASHER, front spindle t=3 (deviation -0.04 - -0.07)	194145-11980	-		10			
25- 24	WASHER, front spindle t=3 (deviation -0.08 - -0.11)	194145-11990	-		10			

Fig. 25 FRONT AXLE (FOR MODEL YM241)

Refer. No.	Description	Part No.	Qty/Unit		Sales Unit	Interchange-ability	Designchange Mark	Remarks
			YM241	YM241D				
25- 25	BALL BEARING #51106	1A1030-12200	2					
25- 26	O-RING 30x2.4	194990-57740	2		10			
25- 27	COTTER PIN 4x45	22417-400450	2		10			
25- 28	KEY 10x8x34	22512-100340	2		10			
25- 29	ARM(L), knuckle	X-194240-14110	1					
25- 30	ARM(R), knuckle	X-194240-14210	1					
25- 31	SPRING WASHER 12	22217-120000	2		10			
25- 32	BOLT M12x60	26116-120602	2		10			
25- 33	TIE-ROD	X-194432-12310	1					
25- 34	CLAMP, tie-rod	194130-12321	4					
25- 35	BOLT M10x38	194130-12330	4		10			
25- 36	EXTENSION(L), tie-rod	X-194432-12340	1					
25- 37	EXTENSION(R), tie-rod	X-194432-12350	1					
25- 38	NUT M17(LH screw)	194990-22830	1		10			
25- 39	NUT M17(RH screw)	194990-22840	1		10			
25- 40	TIE-ROD END ASS'Y(RL)	X-794730-57122	1					
25- 41	.TIE-ROD END(RL)	*	1		*		Order ASS'Y (194730-57161)	
25- 42	.BOOT, tie-rod end	194730-57220	1					
25- 43	.CASTLE NUT M12	194730-57241	1		10			
25- 44	.GREASE NIPPLE 1/4	194730-57411	1		10			
25- 45	.COTTER PIN 3x25	22417-300250	1		10			
25- 46	TIE-ROD END ASS'Y(LR)	X-794730-57132	1					
25- 47	.TIE-ROD END(LR)	*	1		*		Order ASS'Y (194730-57171)	
25- 48	.BOOT, tie-rod end	194730-57220	1					
25- 49	.CASTLE NUT M12	194730-57241	1		10			
25- 50	.GREASE NIPPLE 1/4	194730-57411	1		10			
25- 51	.COTTER PIN 3x25	22417-300250	1		10			

Nov., 1981

- 77 -

Nov., 1981

Fig. 25 FRONT AXLE (FOR MODEL YM241)

Refer. No.	Description	Part No.	Qty/Unit		Sales Unit	Interchange-ability	Designchange Mark	Remarks
			YM241	YM241D				
25- 52	COTTER PIN 2.5x25	22417-250250	4		10			
25- 53	CASTLE NUT M10	26837-100002	4		10			
25- 54	HUB, front wheel	X-194145-12611	2					
25- 55	PACKING, hub cover	194145-12630	2					
25- 56	COVER, wheel hub	X-194145-12640	2					
25- 57	SEAL TCx6 40 62 19, oil	194130-12720	2					
25- 58	SPRING WASHER 14	194465-14220	12		10			
25- 59	BOLT M14x28	194464-47890	12		10			
25- 60	SPRING WASHER 6	22217-060000	8		10			
25- 61	BOLT M6x12	26116-060122	8		10			

Nov., 1981

- 78 -

Nov., 1981

Fig. 26 PROPELLER SHAFT OF FRONT AXLE [FOR MODEL YM241D]

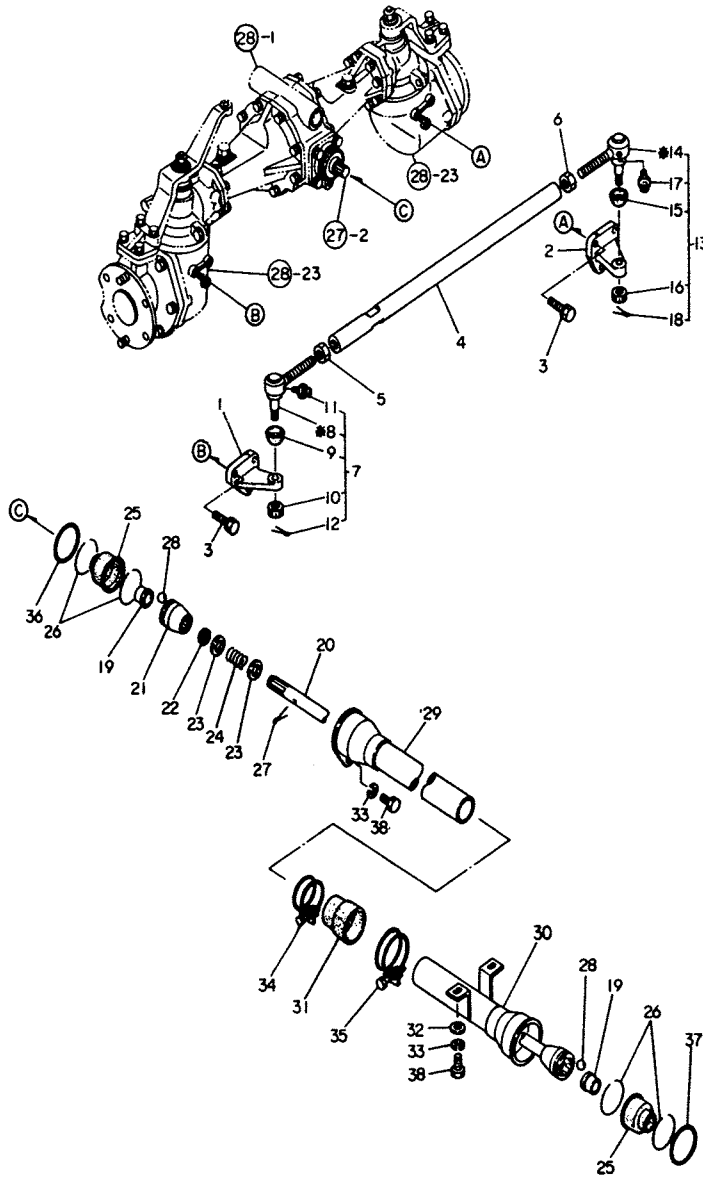

\* MARK PARTS: NOT SOLD SEPARATELY.

Fig. 26 PROPELLER SHAFT OF FRONT AXLE (FOR MODEL YM241D)

Refer. No.	Description	Part No.	Q'ty/Unit		Sales Unit	Interchangeability	Designation Mark	Remarks
			YM241	YM241D				
26- 1	ARM(L), knuckle	X-194311-12110		1				
26- 2	ARM(R), knuckle	X-194311-12210		1				
26- 3	BOLT M10x28	26013-100282		6	10			
26- 4	TIE-ROD	X-194311-12310		1				
26- 5	NUT M17(LH screw)	194990-22830		1				
26- 6	NUT M17(RH screw)	194990-22840		1				
26- 7	TIE-ROD END ASS'Y(RL)	X-794730-57122		1				
26- 8	TIE-ROD END(RL)	*		1	*			Order ASS'Y (194730-57161)
26- 9	BOOT, tie-rod end	194730-57220		1				
26- 10	CASTLE NUT M12	194730-57241		1	10			
26- 11	GREASE NIPPLE 1/4	194730-57411		1	10			
26- 12	COTTER PIN 3x25	22417-300250		1	10			
26- 13	TIE-ROD END ASS'Y(LR)	X-794730-57132		1				
26- 14	TIE-ROD END(LR)	*		1	*			Order ASS'Y (194730-57171)
26- 15	BOOT, tie-rod end	194730-57220		1				
26- 16	CASTLE NUT M12	194730-57241		1	10			
26- 17	GREASE NIPPLE 1/4	194730-57411		1	10			
26- 18	COTTER PIN 3x25	22417-300250		1	10			
26- 19	SLEEVE	194191-13270		2				
26- 20	SHAFT, propeller	X-194241-13301		1				
26- 21	COUPLING(B)	194191-13331		1				
26- 22	SEAL	194191-13340		1				
26- 23	SPACER 20x30x1.6	194191-13350		2				
26- 24	SPRING	194311-13360		1				
26- 25	BOOT, rubber	194191-13370		2				
26- 26	WIRE	194150-51620		4	10			
26- 27	COTTER PIN 4x40	22417-400400		1	10			
26- 28	BALL 5/16	24190-100001		12	10			

Fig. 26 PROPELLER SHAFT OF FRONT AXLE (FOR MODEL YM241D)

Refer. No.	Description	Part No.	Q'ty/Unit		Sales Unit	Interchangeability	Designation Mark	Remarks
			YM241	YM241D				
26- 29	COVER(F), shaft	X-194241-14611		1				
26- 30	COVER(R), shaft	X-194241-14641		1				
26- 31	BOOT, shaft	194311-14650		1				
26- 32	WASHER 10	22137-100000		2	10			
26- 33	SPRING WASHER 10	22217-100000		3	10			
26- 34	CLAMP 50	23010-050000		1	10			
26- 35	CLAMP 55	23010-055000		1	10			
26- 36	O-RING 60-G	24321-000600		1	10			
26- 37	O-RING 60-G	24321-000600		1	10			
26- 38	BOLT M10x16	26126-100162		3	10			

Fig. 27 1st SHAFT & RING GEAR OF FRONT AXLE (FOR MODEL YM241D)

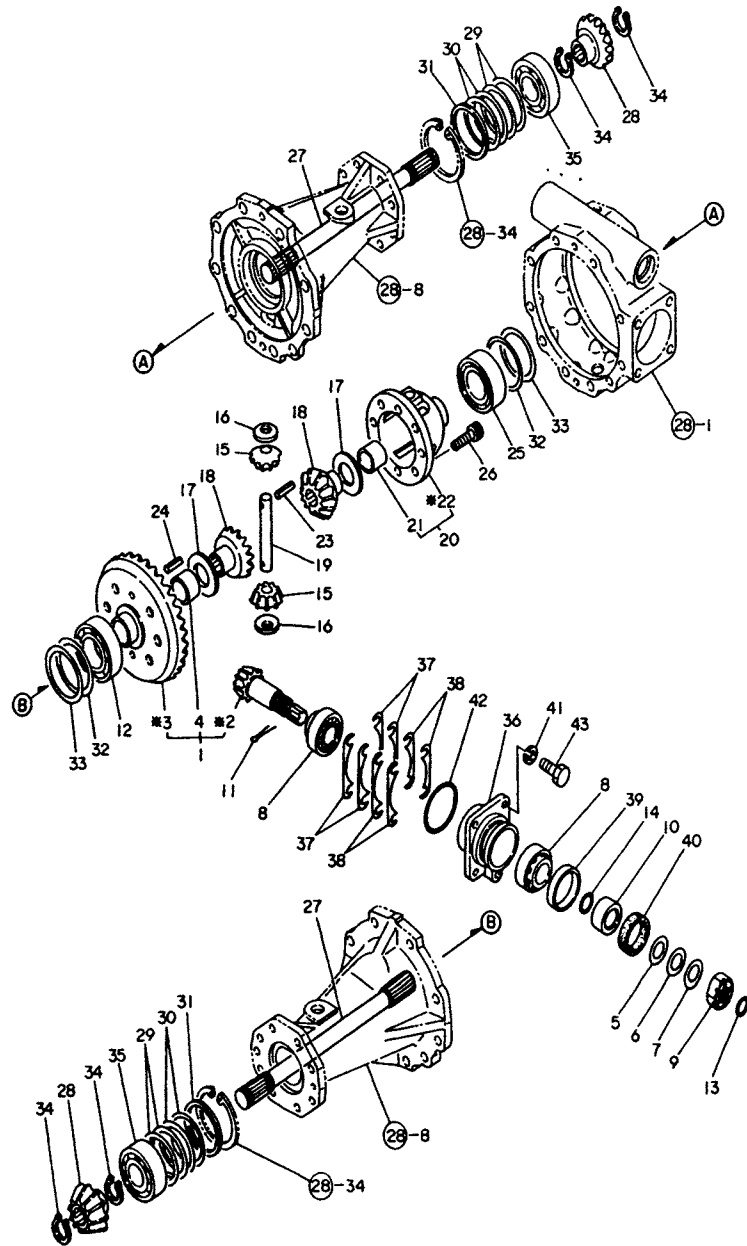

※ MARK PARTS: NOT SOLD SEPARATELY.

Fig. 27 1st SHAFT & RING GEAR OF FRONT AXLE (FOR MODEL YM241D)

Refer. No.	Description	Part No.	Q'ty/Unit		Sales Unit	Interchangeability	Designchange Mark	Remarks
			YM241	YM241D				
27- 1	GEAR ASS'Y, ring	194311-13101		1				
27- 2	.PINION, drive	*		1	*			Order ASS'Y (194311-13111) Order ASS'Y (194311-13120)
27- 3	.GEAR, ring	*		1	*			
27- 4	.BUSH 32x36x20	194190-31490		1				
27- 5	SHIM t=0.4	194311-13130		-	10			} Selective
27- 6	SHIM t=0.5	194311-13140		-	10			
27- 7	SHIM t=0.6	194311-13150		-	10			
27- 8	ROLLER BEARING #HR32006xJ	194191-13530		2				
27- 9	CASTLE NUT M28x1.5	194191-13540		1				
27- 10	COLLAR 28x40x12	194191-13671		1				
27- 11	COTTER PIN 2.5x40	22417-250400		1				
27- 12	BALL BEARING #6009	24101-060094		1				
27- 13	O-RING 21-P	24311-000210		1	10			
27- 14	O-RING 25-S	24341-000250		1	10			
27- 15	PINION, differential	194740-10850		2				
27- 16	WASHER 14x30x0.8, thrust	194740-10870		2	10			
27- 17	WASHER 35x44x0.8, thrust	194740-10880		2	10			
27- 18	GEAR, side	194190-31510		2				
27- 19	SHAFT, pinion	194420-31820		1				
27- 20	HOUSING ASS'Y, differential	194190-32100		1				
27- 21	.BUSH 32x36x20	194190-31490		1				
27- 22	.HOUSING, differential	*		1	*			Order ASS'Y (194190-32113)
27- 23	SPRING PIN 4x25	22351-040025		1	10			
27- 24	SPRING PIN 8x18	22351-080018		2	10			
27- 25	BALL BEARING #6009	24101-060094		1				
27- 26	BROACHED BOLT M8x18	26450-080182		6	10			

Fig. 27 1st SHAFT & RING GEAR OF FRONT AXLE (FOR MODEL YM241D)

Refer. No.	Description	Part No.	Q'ty/Unit		Sales Unit	Interchange-ability	Designchange Mark	Remarks
			YM241	YM241D				
27- 27	SHAFT, front 1st	194311-13510		2				
27- 28	PINION	194311-13520		2				
27- 29	SHIM(A) t=0.2	194311-13530		-	10			} Selective
27- 30	SHIM(B) t=0.3	194311-13540		-	10			
27- 31	SPACER	194311-13550		2				
27- 32	SHIM(A) t=0.3	194190-31120		-	10			} Selective
27- 33	SHIM(B) t=0.2	194190-31130		-	10			
27- 34	CIRCLIP 24-S	22242-000240		4	10			
27- 35	BALL BEARING #6207	24101-062074		2				
27- 36	CAP, front axle case	194311-13450		1				
27- 37	SHIM(A) t=0.3	194311-13460		-	10			} Selective
27- 38	SHIM(B) t=0.2	194311-13470		-	10			
27- 39	COLLAR 52.4x55x6	194191-13662		1				
27- 40	SEAL TC 40 55 8, oil	194191-13681		1				
27- 41	SPRING WASHER 8	22217-080000		4	10			
27- 42	O-RING 63-S	24341-C:0630		1	10			
27- 43	BOLT M8x22	26116-050222		4	10			

Fig. 28 CASING OF FRONT AXLE [FOR MODEL YM241D]

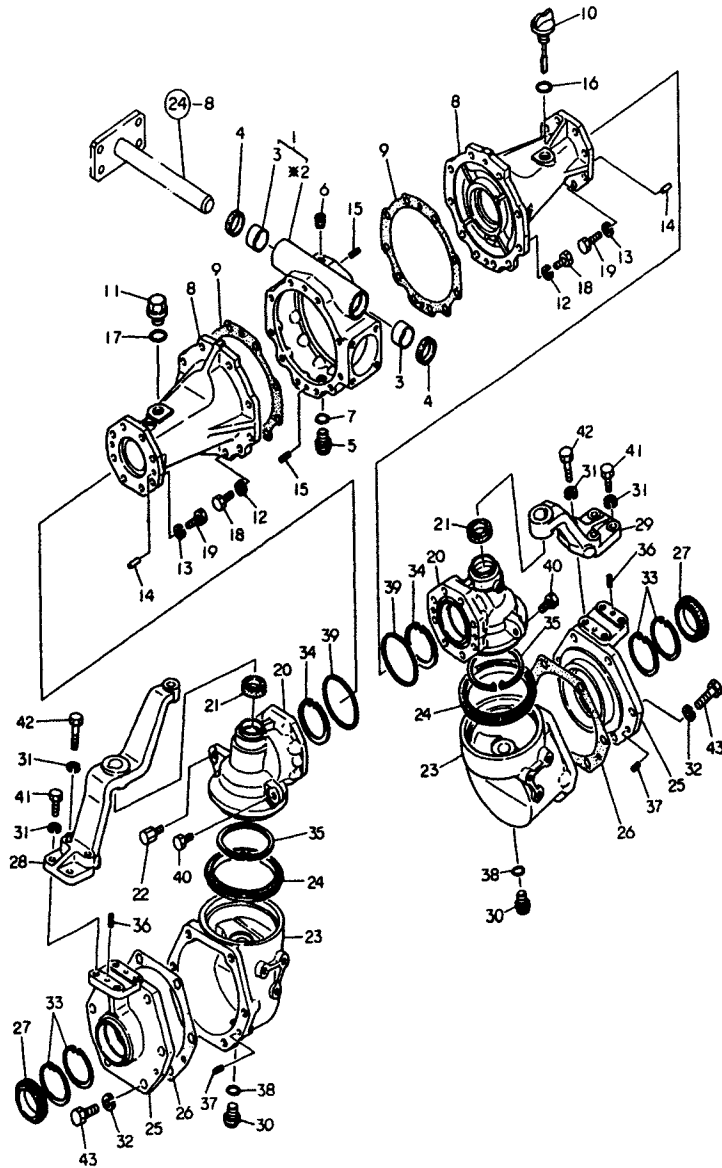

\* MARK PARTS: NOT SOLD SEPARATELY.

Fig. 28 CASING OF FRONT AXLE (FOR MODEL YM241D)

Refer. No.	Description	Part No.	Q'ty/Unit		Sales Unit	Interchangeability	Designchange Mark	Remarks
			YM241	YM241D				
28- 1	CASE ASS'Y	X-194311-13401		1				
28- 2	.CASE, front axle	*		1	*			Order ASS'Y (194311-13411)
28- 3	.BUSH 30x34x25	194311-13420		2				
28- 4	SEAL KC 30 42 7, oil	194311-13430		2				
28- 5	PLUG 14	194151-24770		1	10			
28- 6	TAPER PLUG PT1/8	23873-010000		1	10		D	
	TAPER PLUG PT1/8	23873-010000		1				
28- 7	O-RING 16-P	24311-000160		1	10			
28- 8	AXLE, front	X-194311-13611		2				
28- 9	PACKING, front axle	194311-13620		2	10			
28- 10	DIPSTICK	194311-13631		1				
28- 11	PLUG 20	194145-48370		1				
28- 12	SPRING WASHER 10	22217-100000		20	10			
28- 13	SPRING WASHER 10	22217-100000		16	10			
28- 14	PARALLEL PIN 10x18	22312-100180		4	10			
28- 15	SPRING PIN 8x20	22351-080020		4	10			
28- 16	O-RING 22-P	24311-000220		1	10			
28- 17	O-RING 22-P	24311-000220		1	10			
28- 18	BOLT M10x25	26116-100252		20	10			
28- 19	BOLT M10x28	26116-100282		16	10			
28- 20	CASE, front gear (upper)	X-194311-13710		2				
28- 21	SEAL TCx6 25 40 7, oil	194311-13720		2				
28- 22	BOLT, stopper	194311-13730		2	10			
28- 23	CASE, front gear (lower)	X-194311-13751		2				
28- 24	SEAL TCS 115 145 13.5, oil	194311-13760		2				
28- 25	CAP, front gear case	X-194311-13771		2				
28- 26	PACKING, gear case	194362-13780		2	10			

Fig. 28 CASING OF FRONT AXLE (FOR MODEL YM241D)

Refer. No.	Description	Part No.	Q'ty/Unit		Sales Unit	Interchangeability	Designchange Mark	Remarks
			YM241	YM241D				
28- 27	SEAL TCFY 50 68 14.3, oil	194311-13790		2				
28- 28	BRACKET(L), king pin	X-194311-13810		1				
28- 29	BRACKET(R), king pin	X-194311-13820		1				
28- 30	PLUG 14	194151-24770		2	10			
28- 31	SPRING WASHER 10	22217-100000		8	10			
28- 32	SPRING WASHER 12	22217-120000		12	10			
28- 33	CIRCLIP 68-H	22252-000680		4	10			
28- 34	CIRCLIP 72-H	22252-000720		2	10			
28- 35	CIRCLIP 100-H	22252-001000		2	10			
28- 36	SPRING PIN 8x20	22351-080020		4	10			
28- 37	SPRING PIN 8x20	22351-080020		4	10			
28- 38	O-RING 16-P	24311-000160		2	10			
28- 39	O-RING 85-G	24321-000850		2	10			
28- 40	BOLT M10x16	26116-100162		2	10			
28- 41	BOLT M10x30	26116-100302		4	10			
28- 42	BOLT M10x45	26116-100452		4	10			
28- 43	BOLT M12x35	26116-120352		12	10			



Fig. 29 2nd SHAFT & SPINDLE OF FRONT AXLE [FOR MODEL YM241D]

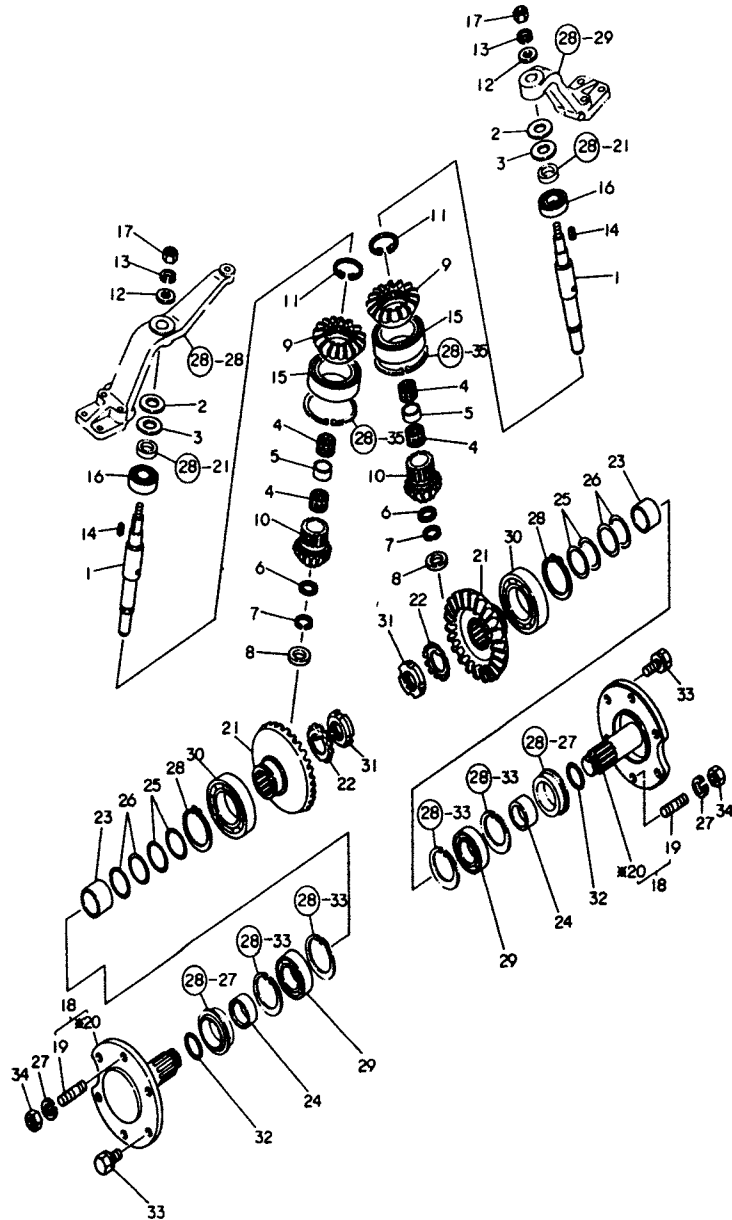

※ MARK PARTS: NOT SOLD SEPARATELY.

Fig. 29 2nd SHAFT & SPINDLE OF FRONT AXLE (FOR MODEL YM241D)

Refer. No.	Description	Part No.	Q'ty/Unit		Sales Unit	Interchangeability	Discharge Mark	Remarks
			YM241	YM241D				
29- 1	SHAFT, front 2nd	194311-13850		2				
29- 2	SHIM(A) t=1.0	194311-13860		-	10			} Selective
29- 3	SHIM(B) t=1.2	194311-13870		-	10			
29- 4	NEEDLE BEARING #K283518	194311-13880		4				
29- 5	COLLAR 28x33.5x22.5	194311-13890		2				
29- 6	WASHER 28x33.5x2, thrust	194311-13910		2				
29- 7	CIRCLIP WR28	194311-13920		2				
29- 8	SPACER 25x35x5	194311-13930		2				
29- 9	GEAR	194311-13940		2				
29- 10	PINION	194311-13950		2				
29- 11	CIRCLIP 50-S	194311-13960		2				
29- 12	WASHER 16	22137-160000		2	10			
29- 13	SPRING WASHER 16	22217-160000		2	10			
29- 14	KEY 7x7x22	22512-070220		2	10			
29- 15	BALL BEARING #6013	24101-060134		2				
29- 16	BALL BEARING #6205	24101-062054		2				
29- 17	NUT M16	26716-160002		2	10			
29- 18	SPINDLE ASS'Y, front	X-194311-14101		2				Order ASS'Y (194311-14112)
29- 19	.STUD M14x24	194145-12620		4				
29- 20	. SPINDLE, front	*		2	*			
29- 21	GEAR, front final	194311-14121		2				
29- 22	WASHER 35	194311-14130		2				
29- 23	COLLAR 48.6x38.5	194311-14161		2				
29- 24	COLLAR 40x50x20	194311-14172		2				

Fig. 29 2nd SHAFT & SPINDLE OF FRONT AXLE (FOR MODEL YM241D)

Refer. No.	Description	Part No.	Q'ty/Unit		Sales Unit	Interchange-ability	Designchange Mark	Remarks
			YM241	YM241D				
29- 25	SHIM(A) t=0.2	194311-14180	-	10				} Selective
29- 26	SHIM(B) t=0.3	194311-14190	-	10				
29- 27	SPRING WASHER 14	22217-140000	4	10				
29- 28	CIRCLIP 55-S	22242-000550	2	10				
29- 29	BALL BEARING #6008	24101-060084	2					
29- 30	BALL BEARING #6211	24101-062114	2					
29- 31	NUT M35	24211-035002	2	10				
29- 32	O-RING 40-G	24321-000400	2	10				
29- 33	BOLT M14x25	26013-140252	8	10				
29- 34	NUT M14	26716-140002	4	10				

Fig. 30 STEERING [FOR MODEL YM241]

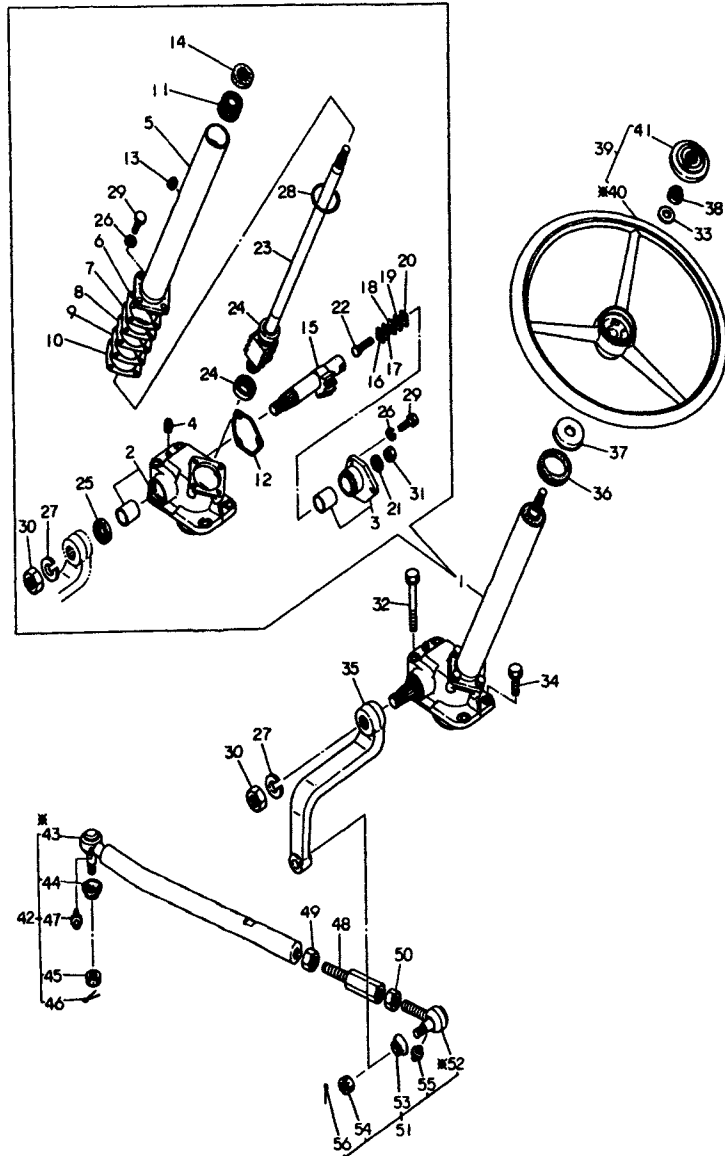

\* MARK PARTS: NOT SOLD SEPARATELY.

Fig. 30 STEERING (FOR MODEL YM241)

Refer. No.	Description	Part No.	Qty/Unit		Sales Unit	Interchangeability	Designchange Mark	Remarks
			YM241	YM241D				
30- 1	GEAR ASS'Y, steering	X-194241-15100	1					
30- 2	.BODY w/BUSH	X-194241-15110	1					
30- 3	.COVER w/BUSH, side	X-194310-15150	1					
30- 4	.PLUG PT01	194310-15170	1		10			
30- 5	.COLUMN	X-194241-15200	1					
30- 6	.SHIM t=0.05	194750-15250	-		10		Selective	
30- 7	.SHIM t=0.07	194750-15260	-		10			
30- 8	.SHIM t=0.08	194750-15270	-		10			
30- 9	.SHIM t=0.1	194750-15280	-		10			
30- 10	.SHIM t=0.2	194750-15290	-		10			
30- 11	.BUSH, column	194241-15310	1					
30- 12	.PACKING, side cover	194310-15320	1					
30- 13	.PLUG, rubber	194440-15340	1					
30- 14	.SEAL, oil	194241-15350	1					
30- 15	.SHAFT, sector	194310-15411	1					
30- 16	.SHIM, adjust screw t=1.5 (deviation+0.035 - +0.05)	194080-15420	-		10		Selective	
30- 17	.SHIM, adjust screw t=1.5 (deviation+0.065 - +0.045)	194080-15430	-		10			
30- 18	.SHIM, adjust screw t=1.5 (deviation+0.095 - +0.075)	194080-15440	-		10			
30- 19	.SHIM, adjust screw t=1.5 (deviation+0.125 - +0.105)	194080-15450	-		10			
30- 20	.SHIM, adjust screw T=1.5 (deviation+0.155 - +0.135)	194080-15460	-		10			
30- 21	.SEAL WASHER	194464-15450	1		10			
30- 22	.ADJUST SCREW	194130-15470	1		10			
30- 23	.BALL NUT	194241-15500	1					

Fig. 30 STEERING (FOR MODEL YM241)

Refer. No.	Description	Part No.	Q'ty/Unit		Sales Unit	Interchange-ability	Designchange Mark	Remarks
			YM241	YM241D				
30- 24	.BEARING	194750-15520	2					
30- 25	.SEAL, oil	194740-55620	1					
30- 26	.SPRING WASHER 8	22217-080000	7		10			
30- 27	.SPRING WASHER 20	22217-200000	1		10			
30- 28	.O-RING 50-G	24321-000500	1		10			
30- 29	.BOLT M8x22	26116-080222	7		10			
30- 30	.NUT M20	26736-200002	1		10			
30- 31	.LOCK NUT M10	26776-100002	1		10			
30- 32	BOLT M10x80	194310-15181	2					
30- 33	WASHER 12	194080-15550	1					
30- 34	BOLT M10x32	194190-15560	2		10			
30- 35	ARM, pitman	X-194151-15610	1					
30- 36	GROMMET 42	194145-15651	1					
30- 37	GUIDE, column	194159-15720	1					
30- 38	U-NUT M12	26356-120002	1		10			
30- 39	WHEEL ASS'Y, steering	194420-15700	1					
30- 40	.WHEEL, steering	*	1		*		Order ASS'Y (194420-15710)	
30- 41	.CAP, steering wheel	194440-15870	1					
30- 42	ROD ASS'Y, drag	X-194242-16100	1					
30- 43	.ROD, drag	*	1		*		Order ASS'Y (194242-16110)	
30- 44	.BOOT, tie-rod end	194730-57220	1					
30- 45	.CASTLE NUT M12	194730-57241	1		10			
30- 46	.COTTER PIN 3x25	22417-300250	1		10			
30- 47	.GREASE NIPPLE M76x1	24761-060000	1		10			

Fig. 30 STEERING (FOR MODEL YM241)

Refer. No.	Description	Part No.	Q'ty/Unit		Sales Unit	Interchange-ability	Designchange Mark	Remarks
			YM241	YM241D				
30- 48	TURNBUCKLE	X-194464-16130	1					
30- 49	NUT M17 (LH screw)	194990-22830	1		10			
30- 50	NUT M17 (RH screw)	194990-22840	1		10			
30- 51	TIE-ROD END ASS'Y (RL)	X-794730-57122	1					
30- 52	.TIE-ROD END (RL)	*	1		*		Order ASS'Y (194730-57161)	
30- 53	.BOOT, tie-rod end	194730-57220	1					
30- 54	.CASTLE NUT M12	194730-57241	1		10			
30- 55	.GREASE NIPPLE M76x1	24761-060000	1		10			
30- 56	.COTTER PIN 3x25	22417-300250	1		10			

Fig. 31 STEERING (FOR MODEL YM241D)

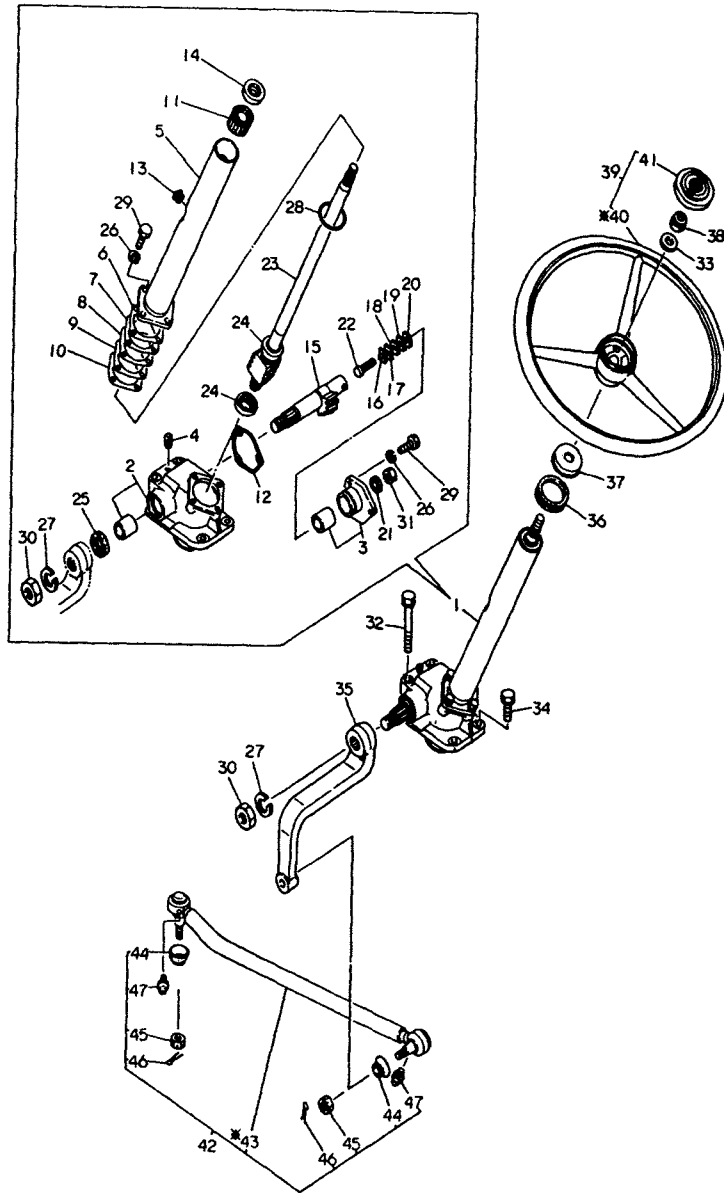

MARK PARTS: NOT SOLD SEPARATELY.

Fig. 31 STEERING (FOR MODEL YM241D)

Refer. No.	Description	Part No.	Q'ty/Unit		Sales Unit	Interchangeability	Designchange Mark	Remarks
			YM241	YM241D				
31- 1	GEAR ASS'Y, steering	X-194241-15100		1				
31- 2	.BODY w/BUSH	X-194241-15110		1				
31- 3	.COVER w/BUSH, side	X-194310-15150		1				
31- 4	.PLUG PT01	194310-15170		1	10			
31- 5	.COLUMN	X-194241-15200		1				
31- 6	.SHIM t=0.05	194750-15250		-	10			Selective
31- 7	.SHIM t=0.07	194750-15260		-	10			
31- 8	.SHIM t=0.08	194750-15270		-	10			
31- 9	.SHIM t=0.1	194750-15280		-	10			
31- 10	.SHIM t=0.2	194750-15290		-	10			
31- 11	.BUSH, column	194241-15310		1				
31- 12	.PACKING, side cover	194310-15320		1				
31- 13	.PLUG, rubber	194440-15340		1				
31- 14	.SEAL, oil	194241-15350		1				
31- 15	.SHAFT, sector	194310-15411		1				
31- 16	.SHIM, adjust screw t=1.5(deviation+0.035 - +0.05)	194080-15420		-	10			Selective
31- 17	.SHIM, adjust screw t=1.5(deviation+0.065 - +0.045)	194080-15430		-	10			
31- 18	.SHIM, adjust screw t=1.5(deviation+0.095 - +0.075)	194080-15440		-	10			
31- 19	.SHIM, adjust screw t=1.5(deviation+0.125 - +0.105)	194080-15450		-	10			
31- 20	.SHIM, adjust screw T=1.5(deviation+0.155 - +0.135)	194080-15460		-	10			
31- 21	.SEAL WASHER	194464-15450		1	10			
31- 22	.ADJUST SCREW	194130-15470		1	10			
31- 23	.BALL NUT	194241-15500		1				
31- 24	.BEARING	194750-15520		2				
31- 25	.SEAL, oil	194740-55620		1				

Fig. 31 STEERING (FOR MODEL YM241D)

Refer. No.	Description	Part No.	Q'ty/Unit		Sales Unit	Interchangeability	Designchange Mark	Remarks
			YM241	YM241D				
31- 26	.SPRING WASHER 8	22217-080000		7	10			
31- 27	.SPRING WASHER 20	22217-200000		1	10			
31- 28	.O-RING 50-G	24321-000500		1	10			
31- 29	.BOLT M8x22	26116-080222		7	10			
31- 30	.NUT M20	26736-200002		1				
31- 31	.LOCK NUT M10	26776-100002		1	10			
31- 32	BOLT M10x80	194310-15181		2				
31- 33	WASHER 12	194080-15550		1				
31- 34	BOLT M10x32	194190-15560		2	10			
31- 35	ARM, pitman	X-194151-15610		1				
31- 36	GROMMET 42	194145-15651		1				
31- 37	GUIDE, column	194159-15720		1				
31- 38	U-NUT M12	26356-120002		1	10			
31- 39	WHEEL ASS'Y, steering	194420-15700		1				
31- 40	.WHEEL, steering	*		1	*			Order ASS'Y (194420-15710)
31- 41	.CAP, steering wheel	194440-15870		1				
31- 42	ROD ASS'Y, drag	X-194287-16101		1				
	ROD ASS'Y, drag	X-194287-16102		1		C		Effective from YM241 -T/#20201 YM241D-T/#40195
31- 43	.ROD, drag	*		1	*			Order ASS'Y (194287-16112)
	.ROD, drag	*		1	*	C		Order ASS'Y (194287-16113)
31- 44	.BOOT, tie-rod end	194730-57220		2				
31- 45	.CASTLE NUT M12	194730-57241		2	10			
31- 46	.COTTER PIN 3x25	22417-300250		2	10			
31- 47	.GREASE NIPPLE MT6x1	24761-060000		2	10			

Fig. 32 CLUTCH HOUSING (FOR MODEL YM241)

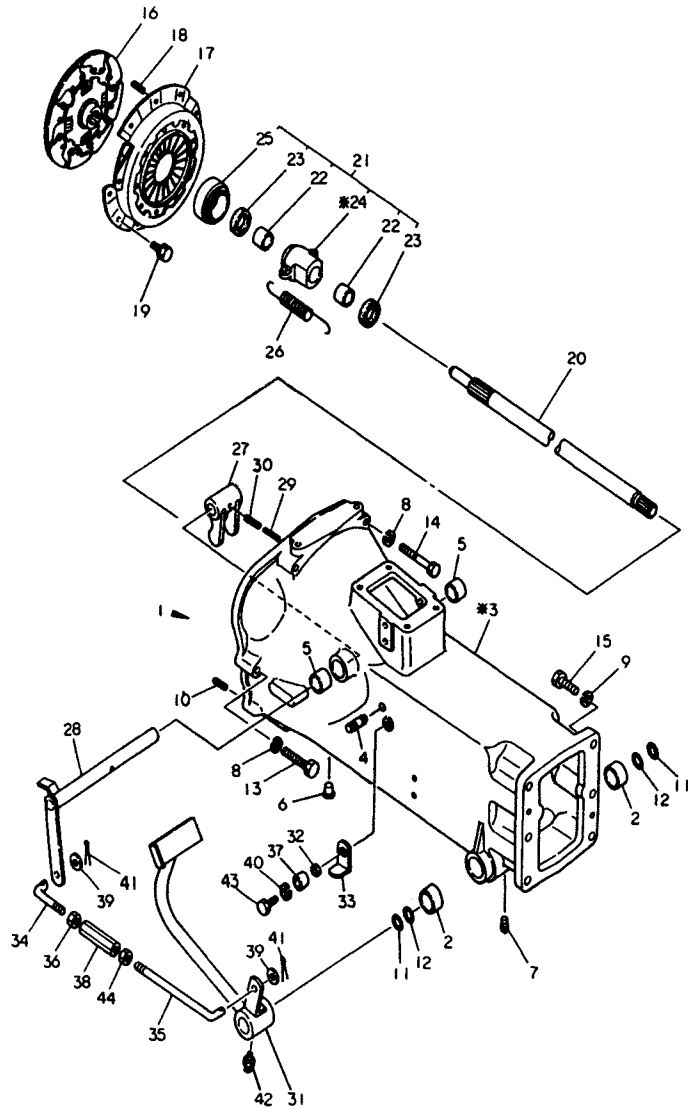

※ MARK PARTS: NOT SOLD SEPARATELY.

Fig. 32 CLUTCH HOUSING (FOR MODEL YM241)

Refer. No.	Description	Part No.	Q'ty/Unit		Sales Unit	Interchangeability	Designchange Mark	Remarks
			YM241	YM241D				
32- 1	HOUSING ASS'Y, clutch	X-794161-21110	1					
32- 2	.BUSH 25x30x18, pedal	194740-06080	2					
32- 3	.HOUSING, clutch	*	1		*			Order ASS'Y (194165-21120)
32- 4	.PIN, spring hook	194150-22250	2		10			
32- 5	.BUSH 20x25x25	194130-22280	2					
32- 6	PLUG 11	194150-21910	5		10			
32- 7	PLUG PT02	194151-36670	1		10			
32- 8	SPRING WASHER 10	22217-100000	6		10			
32- 9	SPRING WASHER 12	22217-120000	6		10			
32- 10	SPRING PIN 8x18	22351-080018	2		10			
32- 11	O-RING 25-G	24321-000250	2		10			
32- 12	O-RING 25-S	24341-000250	2		10			
32- 13	BOLT M10x65	26116-100652	4		10			
32- 14	BOLT M10x80	26116-100802	2		10			
32- 15	BOLT M12x35	26116-120352	6		10			
32- 16	DISC ASS'Y, clutch	794150-21400	1					
32- 17	PLATE ASS'Y, pressure	794150-21700	1					
32- 18	SPRING PIN 8x18	22351-080018	3		10			
32- 19	BOLT M8x16	26013-080162	6		10			
32- 20	SHAFT, main driving	194160-22110	1					
32- 21	SLEEVE w/BEARING ASS'Y	794150-22150	1					
32- 22	.BUSH 22x28x22	194150-22160	2					
32- 23	.FELT	194130-22170	2					
32- 24	.BEARING	*	1		*			Order ASS'Y (194150-22220)
32- 25	.BEARING, clutch SF0815 or TK40-14	194990-42710	1					

Fig. 32 CLUTCH HOUSING (FOR MODEL YM241)

Refer. No.	Description	Part No.	Qty/Unit		Sales Unit	Interchangeability	Discharge Part	Remarks
			YM241	YM241D				
32- 26	SPRING, return	194150-22240	2					
32- 27	YOKE, clutch shift	194150-22310	1					
32- 28	SHAFT, clutch release	X-194241-22330	1					
32- 29	SPRING PIN 3.5x32	22351-035032	1		10			
32- 30	SPRING PIN 6x32	22351-060032	1		10			
32- 31	PEDAL, clutch	X-194150-22410	1					
32- 32	SPACER 8x18x4	194145-22430	1					
32- 33	LEVER, pedal lock	194145-22440	1					
32- 34	ROD(LH screw), clutch	194150-22460	1					
32- 35	ROD(RH screw), clutch	194150-22470	1					
32- 36	NUT M10(LH screw)	194150-22480	1		10			
32- 37	STOPPER, clutch pedal	194165-22490	1					
32- 38	TURNBUCKLE M10x90	194151-37730	1					
32- 39	WASHER 10	22137-100000	2		10			
32- 40	SPRING WASHER 8	22217-080000	1		10			
32- 41	COTTER PIN 2x30	22417-200300	2		10			
32- 42	GREASE NIPPLE M6F	24761-010000	1		10			
32- 43	BOLT M8x40	26116-080402	1		10			
32- 44	NUT M10	26716-100002	1		10			



Fig. 33 CLUTCH HOUSING (FOR MODEL YM241D)

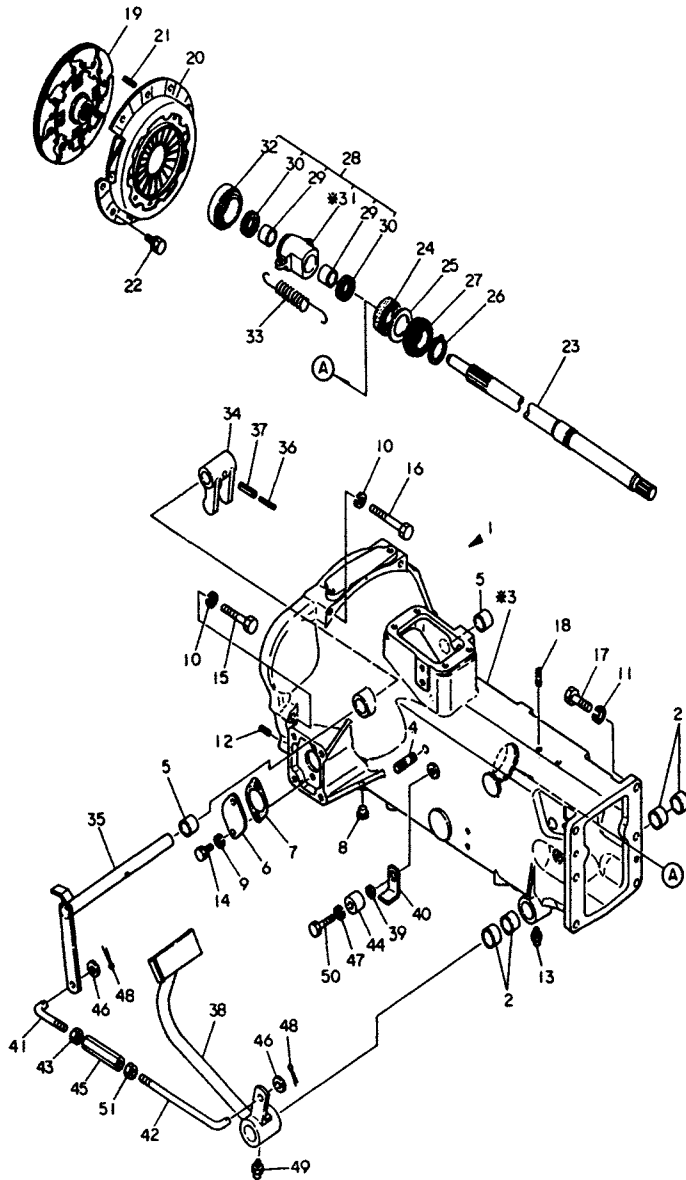

\* MARK PARTS: NOT SOLD SEPARATELY.

Fig. 33 CLUTCH HOUSING (FOR MODEL YM241D)

Refer. No.	Description	Part No.	Qty/Unit		Sales Unit	Interchangeability	Designchange Mark	Remarks
			YM241	YM241D				
33- 1	HOUSING ASS'Y, clutch	X-194241-21110		1				
33- 2	.BUSH 25x30x18, pedal	194740-06080		4				
33- 3	.HOUSING, clutch	*		1	*			Order ASS'Y (194241-21120)
33- 4	.PIN, spring hook	194150-22250		2	10			
33- 5	.BUSH 20x25x25	194130-22280		2				
33- 6	COVER, side	X-194146-21150		1				
33- 7	PACKING, side cover	194146-21160		1	10			
33- 8	PLUG 11	194150-21910		13	10			
33- 9	SPRING WASHER 8	22217-080000		2	10			
33- 10	SPRING WASHER 10	22217-100000		6	10			
33- 11	SPRING WASHER 12	22217-120000		6	10			
33- 12	SPRING PIN 8x18	22351-080018		2	10			
33- 13	GREASE NIPPLE M6F	24761-010000		2	10			
33- 14	BOLT M8x20	26116-080202		2	10			
33- 15	BOLT M10x65	26116-100652		4	10			
33- 16	BOLT M10x80	26116-100802		2	10			
33- 17	BOLT M12x35	26116-120352		6	10			
33- 18	STUD M10x16	26286-100162		2	10			
33- 19	DISC ASS'Y, clutch	794150-21400		1				
33- 20	PLATE ASS'Y, pressure	794150-21700		1				
33- 21	SPRING PIN 8x18	22351-080018		3	10			
33- 22	BOLT M8x16	26013-080162		6	10			
33- 23	SHAFT, main driving	194241-22100		1				
33- 24	SEAL TC 30 55 12, oil	194241-22250		1				
33- 25	SPACER 46x54.5x1	194241-22260		1				

Fig. 33 CLUTCH HOUSING (FOR MODEL YM241D)

Refer. No.	Description	Part No.	Qty/Unit		Sales Unit	Interchange-ability	Designchange Mark	Remarks
			YM241	YM241D				
33- 26	CIRCLIP 30-S	22242-000300		1	10			
33- 27	BALL BEARING #6006N	24121-060064		1				
33- 28	SLEEVE w/BEARING ASS'Y	794150-22150		1				
33- 29	.BUSH 22x28x22	194150-22160		2				
33- 30	.FELT	194130-22170		2				
33- 31	.SLEEVE, bearing	*		1	*			Order ASS'Y (194150-22220)
33- 32	.BEARING, clutch SF0815 or TK40-14	194990-42710		1				
33- 33	SPRING, return	194150-22240		2				
33- 34	YOKE, clutch shift	194150-22310		1				
33- 35	SHAFT, clutch release	X-194241-22330		1				
33- 36	SPRING PIN 3.5x32	22351-035032		1	10			
33- 37	SPRING PIN 6x32	22351-060032		1	10			
33- 38	PEDAL, clutch	X-194150-22410		1				
33- 39	SPACER 8x18x4	194145-22430		1				
33- 40	LEVER, pedal lock	194145-22440		1				
33- 41	ROD(LH screw), clutch	194150-22460		1				
33- 42	ROD(RH screw), clutch	194150-22470		1				
33- 43	NUT M10(LH screw)	194150-22480		1	10			
33- 44	STOPPER, clutch pedal	194165-22490		1				
33- 45	TURNBUCKLE M10x90	194151-37730		1				
33- 46	WASHER 10	22137-100000		2	10			
33- 47	SPRING WASHER 8	22217-080000		1	10			
33- 48	COTTER PIN 2x30	22417-200300		2	10			
33- 49	GREASE NIPPLE M6F	24761-010000		1	10			
33- 50	BOLT M8x40	26116-080402		1	10			
33- 51	NUT M10	26716-100002		1	10			

Fig. 34 TRANSMISSION HOUSING [FOR MODEL YM241]

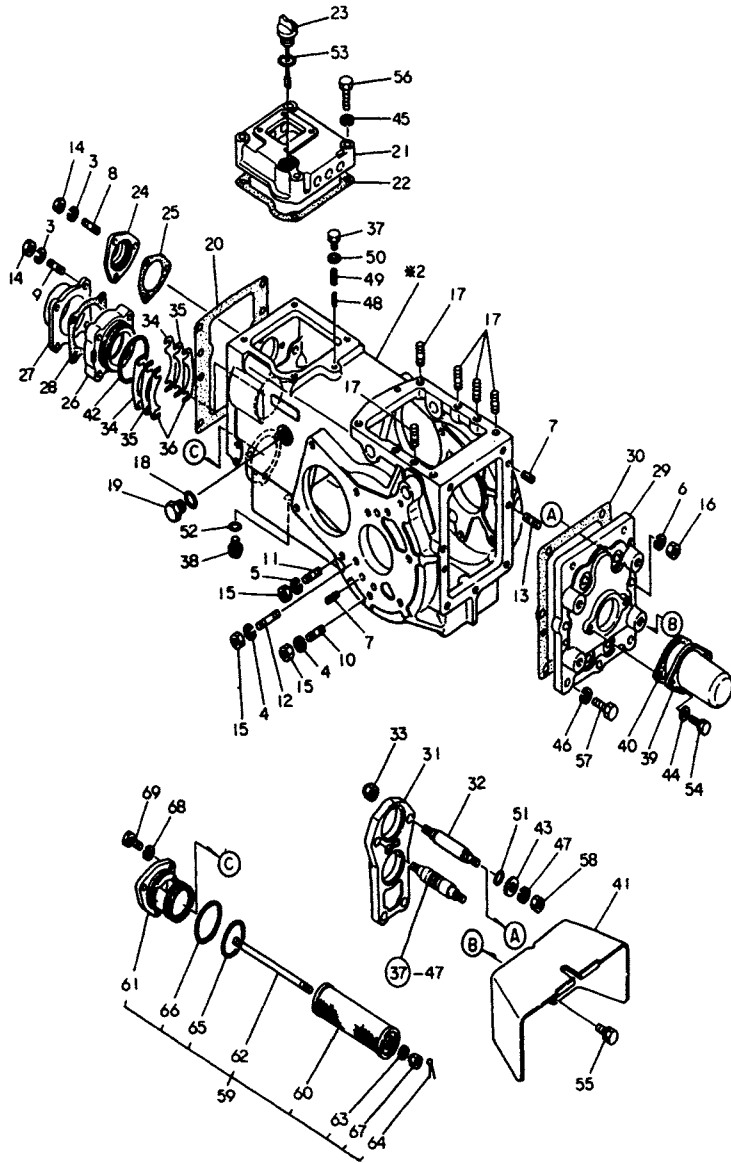

\* MARK PARTS: NOT SOLD SEPARATELY.

Fig. 34 TRANSMISSION HOUSING (FOR MODEL YM241)

Refer. No.	Description	Part No.	Q'ty/Unit		Sales Unit	Interchangeability	Designchange Mark	Remarks
			YM241	YM241D				
34- 1	HOUSING ASS'Y, transmission	X-194242-24100	1					
34- 2	.HOUSING, transmission	*	1		*			Order ASS'Y (194286-24112)
34- 3	.SPRING WASHER 8	22217-080000	7		10			
34- 4	.SPRING WASHER 10	22217-100000	12		10			
34- 5	.SPRING WASHSER 10	22217-100000	4		10			
34- 6	.SPRING WASHER 12	22217-120000	2		10			
34- 7	.SPRING PIN 10x20	22351-100020	8		10			
34- 8	.STUD M8x20	26216-080202	3		10			
34- 9	.STUD M8x50	26216-080502	4		10			
34- 10	.STUD M10x25	26216-100252	8		10			
34- 11	.STUD M10x30	26216-100302	4		10			
34- 12	.STUD M10x45	26216-100452	4		10			
34- 13	.STUD M12x32	26216-120322	2		10			
34- 14	.NUT M8	26716-080002	7		10			
34- 15	.NUT M10	26716-100002	16		10			
34- 16	.NUT M12	26716-120002	2		10			
34- 17	.STUD M10x32	26216-100322	5		10			
34- 18	.O-RING 8-1	194464-45930	1		10			
34- 19	.PLUG 3/4-16UNF	194464-45920	1					
34- 20	PACKING, housing	194150-24160	1		10			
34- 21	COVER, housing	X-194150-24211	1					
34- 22	PACKING, housing cover	194150-24220	1		10			
34- 23	CAP w/DIPSTICK	194150-24290	1					
34- 24	RETAINER, front oil seal	194150-24310	1					

Fig. 34 TRANSMISSION HOUSING (FOR MODEL YM241)

Refer. No.	Description	Part No.	Q'ty/Unit		Sales Unit	Interchangeability	Designchange Mark	Remarks
			YM241	YM241D				
34- 25	PACKING, retainer	194150-24320	1		10			
34- 26	RETAINER, bearing	194286-24340	1					
34- 27	COVER, countershaft	194150-24350	1					
34- 28	PACKING, cover	194150-24360	1		10			
34- 29	COVER, rear	X-194286-24430	1					
34- 30	PACKING, rear cover	194150-24440	1		10			
34- 31	BRACKET, P.T.O.	194286-24451	1					
34- 32	SUPPORTER, P.T.O.	194286-24460	3					
34- 33	U-NUT M14	194282-24471	3		10			
34- 34	SHIM t=0.3	194150-24510	-		10		} Selective	
34- 35	SHIM t=0.2	194150-24520	-		10			
34- 36	SHIM t=0.5	194150-24530	-		10			
34- 37	PLUG 8	194150-24560	1		10			
34- 38	PLUG 14	19151-24770	1		10			
34- 39	COVER, P.T.O. shaft	194190-26860	1					
34- 40	PACKING, P.T.O. cover	194370-26870	1					
34- 41	GUARD, P.T.O. shaft	X-194240-26910	1					
34- 42	O-RING 80-G	194150-27840	1					
34- 43	WASHER 14x26x2	194282-27870	3		10			
34- 44	WASHER 8	22137-080000	2		10			
34- 45	SPRING WASHER 10	22217-100000	4		10			
34- 46	SPRING WASHES 12	22217-120000	5		10			
34- 47	SPRING WASHER 14	22217-140000	3		10			
34- 48	SPRING PIN 3.5x14	22351-035014	1		10			
34- 49	SPRING PIN 6x14	22351-060014	1		10			

Fig. 34 TRANSMISSION HOUSING (FOR MODEL YM241)

Refer. No.	Description	Part No.	Q'ty/Unit		Sales Unit	Interchangeability	Designchange Mark	Remarks
			YM241	YM241D				
34- 50	PACKING 8	23414-080000	1		10			
34- 51	O-RING 14-P	24311-000140	3		10			
34- 52	O-RING 16-P	24311-000160	1		10			
34- 53	O-RING 32-S	24341-000320	1		10			
34- 54	BOLT M8x16	26013-080162	2		10			
34- 55	BOLT M14x25	26013-140252	4		10			
34- 56	BOLT M10x55	26116-100552	4		10			
34- 57	BOLT M12x35	26116-120352	5		10			
34- 58	NUT M14	26736-140002	3		10			
34- 59	STRAINER ASS'Y	X-194241-42300	1					
34- 60	.SCREEN	194241-42310	1					
34- 61	.COVER, strainer	X-194241-42330	1					
34- 62	.STUD, strainer	194241-42340	1					
34- 63	.WASHER 6	22117-060000	1		10			
34- 64	.COTTER PIN 2x12	22417-200120	1		10			
34- 65	.O-RING 50-G	24321-000500	1		10			
34- 66	.O-RING 60-G	24321-000600	1		10			
34- 67	.U-NUT M6	26346-060002	1		10			
34- 68	SPRING WASHER 8	22217-080000	3		10			
34- 69	BOLT M8x20	26116-080202	3		10			

Fig. 35 TRANSMISSION HOUSING [FOR MODEL YM241D]

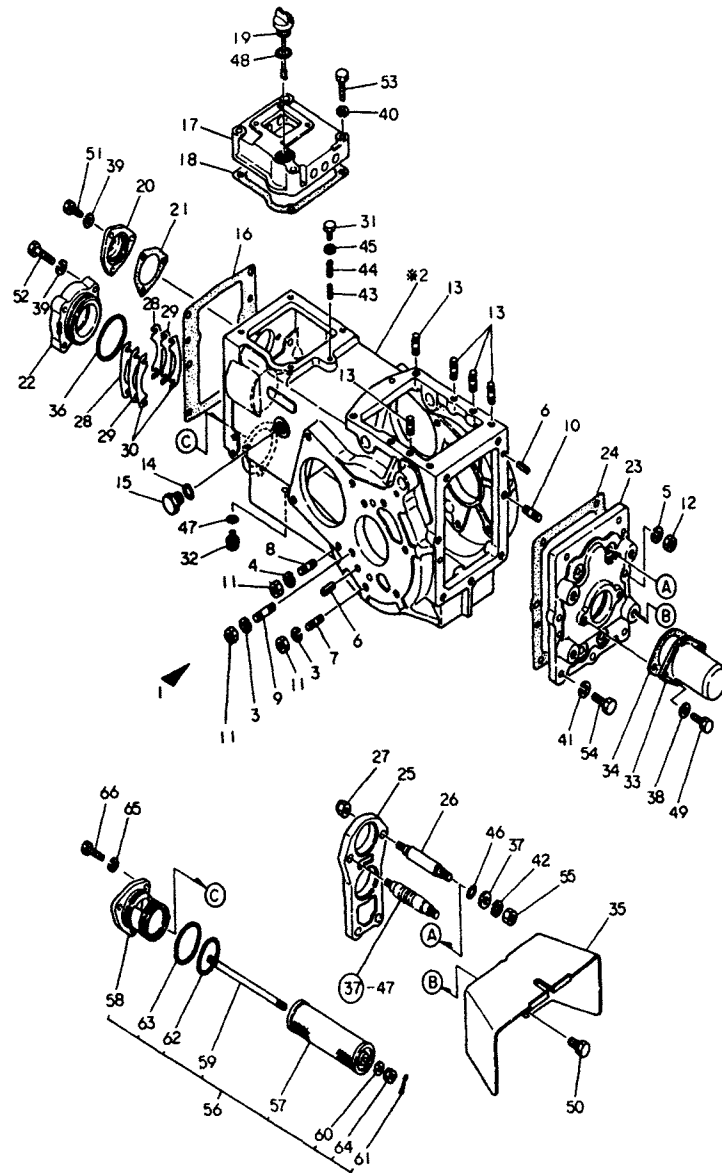

\* MARK PARTS: NOT SOLD SEPARATELY.

Fig. 35 TRANSMISSION HOUSING (FOR MODEL YM241D)

Refer. No.	Description	Part No.	Q'ty/Unit		Sales Unit	Interchangeability	Designation Mark	Remarks
			YM241	YM241D				
35- 1	HOUSING ASS'Y, transmission	X-194243-24100		1				
35- 2	.HOUSING, transmission	*		1	*			Order ASS'Y (194286-24112)
35- 3	.SPRING WASHER 10	22217-100000		12	10			
35- 4	.SPRING WASHSER 10	22217-100000		4	10			
35- 5	.SPRING WASHER 12	22217-120000		2	10			
35- 6	.SPRING PIN 10x20	22351-100020		8	10			
35- 7	.STUD M10x25	26216-100252		8	10			
35- 8	.STUD M10x30	26216-100302		4	10			
35- 9	.STUD M10x45	26216-100452		4	10			
35- 10	.STUD M12x32	26216-120322		2	10			
35- 11	.NUT M10	26716-100002		16	10			
35- 12	.NUT M12	26716-120002		2	10			
35- 13	.STUD M10x32	26216-100322		5	10			
35- 14	.O-RING 8-1	194464-45930		1	10			
35- 15	.PLUG 3/4-16UNF	194464-45920		1				
35- 16	PACKING, housing	194150-24160		1	10			
35- 17	COVER, housing	X-194150-24211		1				
35- 18	PACKING, housing cover	194150-24220		1	10			
35- 19	CAP w/DIPSTICK	194150-24290		1				
35- 20	RETAINER, front oil seal	194241-24310		1				
35- 21	PACKING, retainer	194150-24320		1	10			
35- 22	RETAINER, bearing	194286-24340		1				
35- 23	COVER, rear	X-194286-24430		1				
35- 24	PACKING, rear cover	194150-24440		1	10			
35- 25	BRACKET, P.T.O.	194286-24451		1				

Fig. 35 TRANSMISSION HOUSING (FOR MODEL YM241D)

Refer. No.	Description	Part No.	Q'ty/Unit		Sales Unit	Interchangeability	Designation Mark	Remarks
			YM241	YM241D				
35- 26	SUPPORTER, P.T.O.	194286-24460		3				
35- 27	U-NUT M14	194282-24471		3	10			
35- 28	SHIM t=0.3	194150-24510		-	10		} Selective	
35- 29	SHIM t=0.2	194150-24520		-	10			
35- 30	SHIM t=0.5	194150-24530		-	10			
35- 31	PLUG 8	194150-24560		1	10			
35- 32	PLUG 14	194151-24770		1	10			
35- 33	COVER, P.T.O. shaft	194190-26860		1				
35- 34	PACKING, P.T.O. cover	194370-26870		1				
35- 35	GUARD, P.T.O. shaft	X-194240-26910		1				
35- 36	O-RING 80-G	194150-27840		1				
35- 37	WASHER 14x26x2	194282-27870		3	10			
35- 38	WASHER 8	22137-080000		2	10			
35- 39	SPRING WASHER 8	22217-080000		7	10			
35- 40	SPRING WASHER 10	22217-100000		4	10			
35- 41	SPRING WASHER 12	22217-120000		5	10			
35- 42	SPRING WASHER 14	22217-140000		3	10			
35- 43	SPRING PIN 3.5x14	22351-035014		1	10			
35- 44	SPRING PIN 6x14	22351-060014		1	10			
35- 45	PACKING 8	23414-080000		1	10			
35- 46	O-RING 14-P	24311-000140		3	10			
35- 47	O-RING 16-P	24311-000160		1	10			
35- 48	O-RING 32-S	24341-000320		1	10			
35- 49	BOLT M8x16	26013-080162		2	10			
35- 50	BOLT M14x25	26013-140252		4	10			

Fig. 35 TRANSMISSION HOUSING (FOR MODEL YM241D)

Refer. No.	Description	Part No.	Q'ty/Unit		Sales Unit	Interchangeability	Designation Mark	Remarks
			YM241	YM241D				
35- 51	BOLT M8x22	26116-080222		3	10			
35- 52	BOLT M8x45	26116-080452		4	10			
35- 53	BOLT M10x55	26116-100552		4	10			
35- 54	BOLT M12x35	26116-120352		5	10			
35- 55	NUT M14	26736-140002		3	10			
35- 56	STRAINER ASS'Y	X-194241-42300		1				
35- 57	.SCREEN	194241-42310		1				
35- 58	.COVER, strainer	X-194241-42330		1				
35- 59	.STUD, strainer	194241-42340		1				
35- 60	.WASHER 6	22117-060000		1	10			
35- 61	.COTTER PIN 2x12	22417-200120		1	10			
35- 62	.O-RING 50-G	24321-000500		1	10			
35- 63	.O-RING 60-G	24321-000600		1	10			
35- 64	.U-NUT M6	26346-060002		1	10			
35- 65	SPRING WASHER 8	22217-080000		3	10			
35- 66	BOLT M8x20	26116-080202		3	10			

Fig. 36 TRANSMISSION GEARS

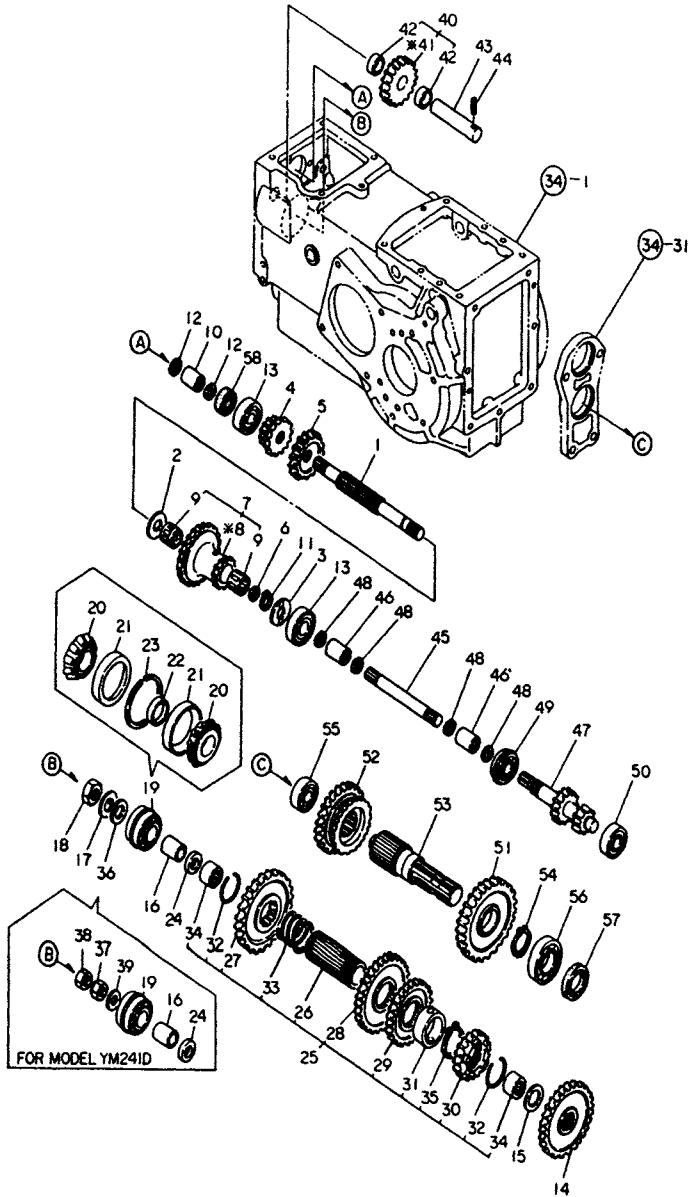

\* MARK PARTS: NOT SOLD SEPARATELY.

Fig. 36 TRANSMISSION GEARS

Refer. No.	Description	Part No.	Q'ty/Unit		Sales Unit	Interchangeability	Designchange Mark	Remarks
			YM241	YM241D				
36- 1	SHAFT, main	194150-25212	1	1				
36- 2	WASHER 20x38x4, thrust	194150-25231	1	1				
36- 3	WASHER, thrust	194150-25260	1	1				
36- 4	GEAR, 1st & 2nd speed sliding	194150-25311	1	1				
36- 5	GEAR, 3rd & 5th speed sliding	194150-25361	1	1				
36- 6	SPACER 20x26x3	194286-25540	1	1				
36- 7	GEAR ASS'Y, reduction	194286-25700	1	1				
36- 8	GEAR, reduction	*	1	1	*			Order ASS'Y (194286-25710)
36- 9	NEEDLE BEARING 20 28 25	194286-25730	2	2				
36- 10	JOINT	194190-26180	1	1				
36- 11	CIRCLIP 20-S	22242-000200	1	1	10			
36- 12	CIRCLIP 17-H	22252-000170	2	2	10			
36- 13	BALL BEARING #6304	24101-063044	2	2				
36- 14	GEAR, range shift	194282-25510	1	1				
36- 15	WASHER 20x43x2.5, thrust	194150-25530	1	1	10			
36- 16	SLEEVE 20x25x40, bearing	194286-25530	1	1				
36- 17	WASHER 20, tongued	194080-25581	1		10			
36- 18	NUT M20	194080-25590	1					
36- 19	BEARING ASS'Y, countershaft	194286-25601	1	1				
36- 20	.ROLLER BEARING	194286-25611	2	2				
36- 21	.RACE, outer	194286-25621	2	2				
36- 22	.SPACER	194286-25631	1	1				
36- 23	.CIRCLIP 65x4.5	194286-25641	1	1	10			
36- 24	SPACER 20x42x7	194150-25771	1	1				

Fig. 36 TRANSMISSION GEARS

Refer. No.	Description	Part No.	Q'ty/Unit		Sales Unit	Interchange-ability	Designchange Mark	Remarks
			YM241	YM241D				
36- 25	GEAR ASS'Y, countershaft	194286-25800	1	1				
36- 26	.SLEEVE, countershaft gear	194150-25810	1	1				
36- 27	.GEAR, 1st speed	194150-25820	1	1				
36- 28	.GEAR, 2nd speed	194150-25830	1	1				
36- 29	.GEAR, 3rd speed	194150-25840	1	1				
36- 30	.GEAR, 5th speed	194286-25850	1	1				
36- 31	.SPACER	194150-25860	1	1				
36- 32	.CIRCLIP 40.5	194150-25870	2	2	10			
36- 33	.SPRING	194150-25880	1	1				
36- 34	.NEEDLE BEARING #HK2526	194150-25890	2	2				
36- 35	.CIRCLIP 45-S	22242-000450	1	1	10			
36- 36	SPACER 20x38x4.5	194190-26340	1					
36- 37	LOCK NUT M16	194287-28540		1	10			
36- 38	LOCK NUT M16	194287-28550		1	10			
36- 39	WASHER 16.5x30x6.5	194287-28560		1				
36- 40	GEAR ASS'Y, reverse	794150-25900	1	1				
36- 41	.GEAR, reverse	*	1	1	*		Order ASS'Y (194150-25910)	
36- 42	.BUSH 20x1.5x15	194130-25922	2	2				
36- 43	SHAFT, reverse	194150-25950	1	1				
36- 44	SPRING PIN 6x16	22351-060016	1	1	10			
36- 45	SHAFT, connecting	194150-25971	1	1				
36- 46	JOINT	194190-26180	2	2				
36- 47	PINION Z=12/19, P.T.O.	194286-26210	1	1				
36- 48	CIRCLIP 17-H	22252-000170	4	4	10			
36- 49	BALL BEARING #6205	24101-062054	1	1				
36- 50	BALL BEARING #6304	24101-063044	1	1				

Nov., 1981

- 121 -

Nov., 1981

Fig. 36 TRANSMISSION GEARS

Refer. No.	Description	Part No.	Q'ty/Unit		Sales Unit	Interchange-ability	Designchange Mark	Remarks
			YM241	YM241D				
36- 51	GEAR, P.T.O. 1st	194286-26230	1	1				
36- 52	GEAR(Z=49), P.T.O. sliding	194286-26260	1	1				
36- 53	SHAFT, P.T.O.	194286-26310	1	1				
36- 54	CIRCLIP 36-S	22242-000360	1	1	10			
36- 55	BALL BEARING #6205	24101-062054	1	1				
36- 56	BALL BEARING #6207	24101-062074	1	1				
36- 57	SEAL TC 35 55 11, oil	194080-09340	1	1				
36- 58	SEAL SC 20 35 8, oil	194150-27810	1					

Nov., 1981

- 122 -

Nov., 1981



Fig. 37 SHIFT LEVERS

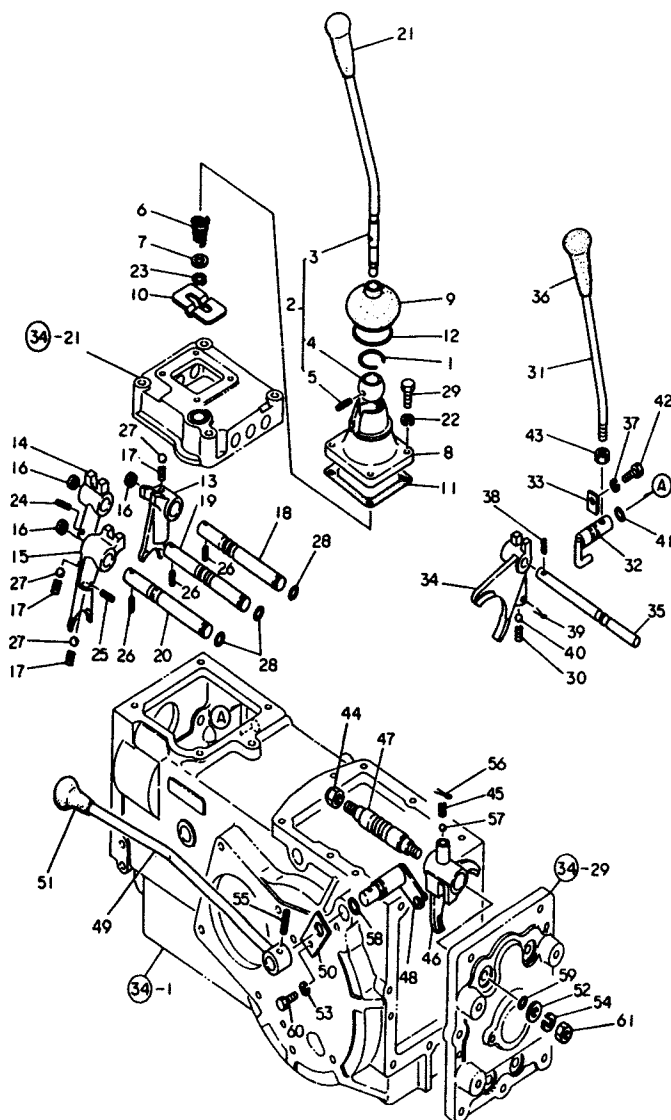

Fig. 37 SHIFT LEVERS

Refer. No.	Description	Part No.	Q'ty/Unit		Sales Unit	Interchangeability	Designation Mark	Remarks
			VM241	VM241D				
37- 1	CIRCLIP 30-H	1A1040-26320	1	1	10			
37- 2	LEVER ASS'Y, gear shift	X-794150-27100	1	1				
37- 3	.LEVER, gear shift	X-194150-27110	1	1				
37- 4	.BALL, shifter	1E4030-27340	1	1				
37- 5	.SPRING PIN 5x40	22351-050040	1	1	10			
37- 6	SPRING, gear shift lever	194080-27172	1	1				
37- 7	WASHER 13x19x2	194080-27190	1	1	10			
37- 8	RETAINER, gear shift lever	194150-27210	1	1				
37- 9	BOOT, rubber	194080-27252	1	1				
37- 10	GUIDE, gear shift lever	194150-27260	1	1				
37- 11	PACKING, retainer	194150-27270	1	1				
37- 12	O-RING	194190-27280	1	1	10			
37- 13	FORK, 1st & 2nd speed shift	194150-27310	1	1				
37- 14	FORK, 3rd & 5th speed shift	194150-27320	1	1				
37- 15	FORK, reverse shift	194150-27330	1	1				
37- 16	CAP 15x5, seal	194130-27390	3	3	10			
37- 17	SPRING, fork lock	194145-27450	3	3	10			
37- 18	SHAFT, 1st & 2nd speed fork	194150-27460	1	1				
37- 19	SHAFT, 3rd & 5th speed fork	194150-27470	1	1				
37- 20	SHAFT, reverse fork	194150-27480	1	1				
37- 21	KNOB, gear shift lever	1A1020-58150	1	1				
37- 22	SPRING WASHER 6	22217-060000	4	4	10			
37- 23	CIRCLIP 12-S	22242-000120	1	1	10			
37- 24	SPRING PIN 3x20	22351-030020	1	1	10			
37- 25	SPRING PIN 3x20	22351-030020	1	1	10			

Fig. 37 SHIFT LEVERS

Refer. No.	Description	Part No.	Qty/Unit		Sales Unit	Interchange-ability	Designchange Mark	Remarks
			YM241	YM241D				
37- 26	SPRING PIN 4x12	22351-040012	3	3	10			
37- 27	BALL 5/16	24190-100001	3	3	10			
37- 28	O-RING 11-P	24311-000110	3	3	10			
37- 29	BOLT M6x16	26116-060162	4	.4	10			
37- 30	SPRING, fork lock	194145-27450	1	1	10			
37- 31	LEVER, range shift	X-194240-27510	1	1				
37- 32	ARM, range shift	194150-27530	1	1				
37- 33	RETAINER, shift lever	194150-27540	1	1				
37- 34	FORK, range shift	194150-27610	1	1				
37- 35	FORK, range shift	194150-27631	1	1				
37- 36	KNOB, range shift lever	194990-85561	1	1				
37- 37	SPRING WASHER 8	22217-080000	1	1	10			
37- 38	SPRING PIN 4x18	22351-040018	1	1	10			
37- 39	COTTER PIN 3x28	22417-300280	1	1	10			
37- 40	BALL 5/16	24190-100001	1	1	10			
37- 41	O-RING 16-P	24311-000160	1	1	10			
37- 42	BOLT M8x16	26116-080162	1	1	10			
37- 43	NUT M12	26716-120002	1	1	10			
37- 44	U-NUT M14	194282-24471	1	1	10			
37- 45	SPRING, fork lock	194145-27450	1	1	10			
37- 46	FORK, P.T.O. shift	194286-27660	1	1				
37- 47	SHAFT, P.T.O. shift fork	194286-27670	1	1				
37- 48	ARM, P.T.O. shift	194286-27680	1	1				
37- 49	LEVER, P.T.O. change	X-194286-27710	1	1				
37- 50	RETAINER	194150-27760	1	1				

Fig. 37 SHIFT LEVERS

Refer. No.	Description	Part No.	Qty/Unit		Sales Unit	Interchange-ability	Designchange Mark	Remarks
			YM241	YM241D				
37- 51	KNOB, P.T.O. shift lever	194155-27810	1	1				
37- 52	WASHER 14x26x2	194282-27870	1	1	10			
37- 53	SPRING WASHER 8	22217-080000	1	1	10			
37- 54	SPRING WASHER 14	22217-140000	1	1	10			
37- 55	SPRING PIN 6x32	22351-060032	1	1	10			
37- 56	COTTER PIN 3x28	22417-300280	1	1	10			
37- 57	BALL 5/16	24190-100001	1	1	10			
37- 58	O-RING 14-P	24311-000140	1	1	10			
37- 59	O-RING 16-P	24311-000160	1	1	10			
37- 60	BOLT M8x16	26116-080162	1	1	10			
37- 61	NUT M14	26736-140002	1	1	10			

Fig. 38 FRONT DRIVE & SHIFT

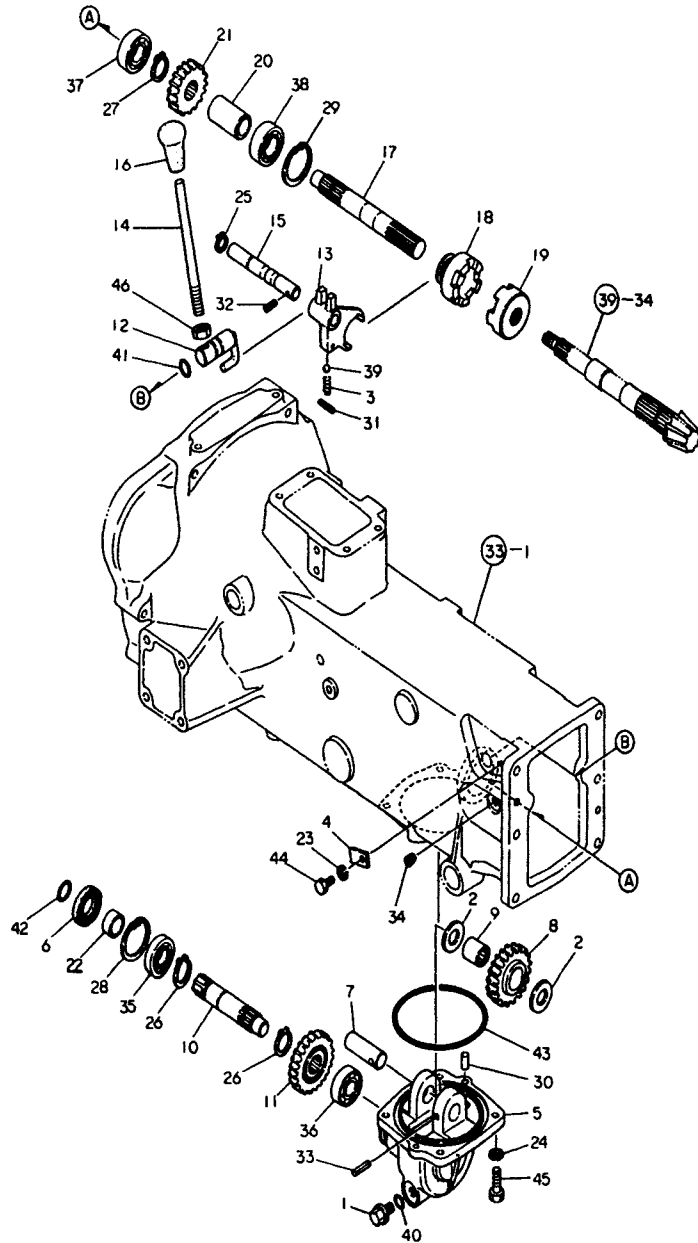

Fig. 38 FRONT DRIVE & SHIFT

Refer. No.	Description	Part No.	Q'ty/Unit		Sales Unit	Interchangeability	Discharge Mark	Remarks
			VM241	VM241D				
38- 1	PLUG 14	194151-24770		1	10			
38- 2	WASHER 20x38x4, thrust	194150-25231		2				
38- 3	SPRING, fork lock	194145-27450		1	10			
38- 4	PLATE, keep	194241-27540		1				
38- 5	CASE, front drive	X-194283-28110		1				
38- 6	SEAL TC 30 47 8, oil	194311-28120		1				
38- 7	SHAFT, idle gear	194241-28151		1				
38- 8	GEAR, idle	194241-28160		1				
38- 9	NEEDLE BEARING #2025	194241-28180		1				
38- 10	SHAFT, front drive	194241-28211		1				
38- 11	GEAR, front drive	194283-28220		1				
38- 12	ARM, shift	194241-28310		1				
38- 13	FORK, shift	194241-28321		1				
38- 14	LEVER, clutch	X-194241-28330		1				
38- 15	SHAFT, fork	194241-28341		1				
38- 16	KNOB	194191-28480		1				
38- 17	SHAFT, clutch	194241-28510		1				
38- 18	CLUTCH (A)	194287-28520		1				
38- 19	CLUTCH (B)	194287-28530		1				
38- 20	COLLAR 25x34x53.5	194241-28540		1				
38- 21	GEAR, front drive	194283-28580		1				
38- 22	SLEEVE SI 25 30 13	1E6190-54080		1				
38- 23	SPRING WASHER 8	22217-080000		1	10			
38- 24	SPRING WASHER 10	22217-100000		4	10			
38- 25	CIRCLIP 15-S	22242-000150		1	10			

Fig. 38 FRONT DRIVE & SHIFT

Refer. No.	Description	Part No.	Qty/Unit		Sales Unit	Interchangeability	Discharge Mark	Remarks
			YM241	YM241D				
38- 26	CIRCLIP 24-S	22242-000240		2	10			
38- 27	CIRCLIP 24-S	22242-000240		1	10			
38- 28	CIRCLIP 47-H	22252-000470		1	10			
38- 29	CIRCLIP 52-H	22252-000520		1	10			
38- 30	PARALLEL PIN 10x18	22312-100180		2	10			
38- 31	SPRING PIN 3x20	22351-030020		1	10			
38- 32	SPRING PIN 6x18	22351-060018		1	10			
38- 33	SPRING PIN 6x36	22351-060036		1	10			
38- 34	TAPER PLUG PT1/8	23873-010000		1	10			
38- 35	BALL BEARING #6005	24101-060054		1	10			
38- 36	BALL BEARING #6204	24101-062044		1				
38- 37	BALL BEARING #6204	24101-062044		1				
38- 38	BALL BEARING #6205	24101-062054		1				
38- 39	BALL 5/16	24190-100001		1	10			
38- 40	O-RING 16-P	24311-000160		1	10			
38- 41	O-RING 16-P	24311-000160		1	10			
38- 42	O-RING 21-P	24311-000210		1	10			
38- 43	O-RING 125-G	24321-001250		1	10			
38- 44	BOLT M8x16	26116-080162		1	10			
38- 45	BOLT M10x30	26116-100302		4	10			
38- 46	NUT M12	26716-120002		1	10			

Fig. 39 DIFFERENTIAL GEARS OF REAR AXLE

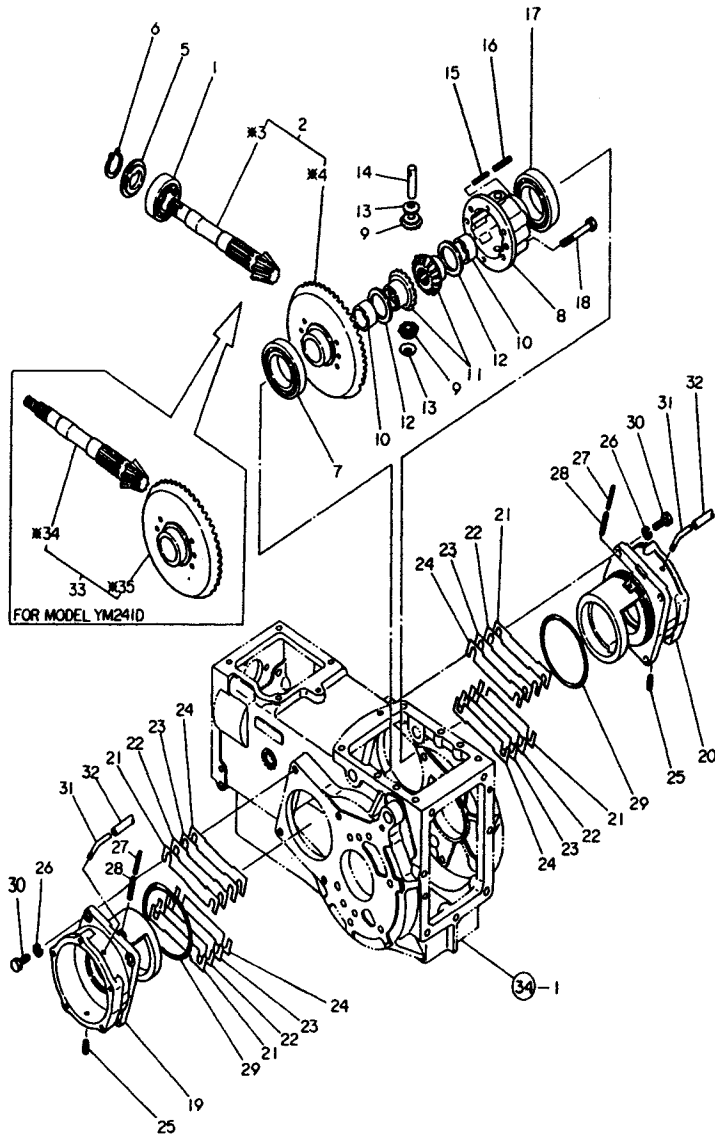

\* MARK PARTS: NOT SOLD SEPARATELY.

Fig. 39 DIFFERENTIAL GEARS OF REAR AXLE

Refer. No.	Description	Part No.	Qty/Unit		Sales Unit	Interchangeability	Designchange Mark	Remarks
			YM241	YM241D				
39- 1	BALL BEARING #NF306	195084-13540	1	1				
39- 2	GEAR w/COUNTERSHAFT	194286-31400	1					
39- 3	.COUNTERSHAFT	*	1		*			Order GEAR w/COUNTERSHAFT (194286-31410)
39- 4	.GEAR, ring	*	1		*			Order GEAR w/COUNTERSHAFT (194286-31420)
39- 5	WASHER 30x64x3.5	194286-31490	1	1				
39- 6	CIRCLIP 30-S	22242-000300	1	1	10			
39- 7	BALL BEARING #6012	24101-060124	1	1				
39- 8	HOUSING, differential	194321-13210	1	1				
39- 9	PINION, differential	194321-13230	2	2				
39- 10	BUSH 40x2x22.5	194281-31490	2	2				
39- 11	GEAR, differential side	194286-31510	2	2				
39- 12	WASHER 41x60x1.0, thrust	194281-31570	2	2				
39- 13	LINER, differential pinion	194281-31580	2	2				
39- 14	SHAFT, differential pinion	194281-31820	1	1				
39- 15	SPRING PIN 3.5x32	22351-035032	1	1	10			
39- 16	SPRING PIN 6x32	22351-060032	1	1	10			
39- 17	BALL BEARING #6012	24101-060124	1	1				
39- 18	BOLT M10x70	26116-100702	6	6	10			
39- 19	CARRIER(L), differential	X-194282-32310	1	1				
39- 20	CARRIER(R), differential	X-194282-32320	1	1				
39- 21	SHIM(A) t=0.2	194150-32330	-	-	10			Selective
39- 22	SHIM(B) t=0.3	194150-32340	-	-	10			
39- 23	SHIM(C) t=1.0	194150-32350	-	-	10			
39- 24	SHIM(D) t=0.1	194150-32360	-	-	10			

Fig. 39 DIFFERENTIAL GEARS OF REAR AXLE

Refer. No.	Description	Part No.	Q'ty/Unit		Sales Unit	Interchangeability	Designchange Mark	Remarks
			YM241	YM241D				
39- 25	PLUG PT02	194151-36670	2	2	10			
39- 26	SPRING WASHER 10	22217-100000	4	4	10			
39- 27	SPRING PIN 3.5x22	22351-035022	4	4	10			
39- 28	SPRING PIN 6x25	22351-060025	4	4	10			
39- 29	O-RING 115-G	24321-001150	2	2	10			
39- 30	BOLT M10x30	26116-100302	4	4	10			
39- 31	JOINT, air breather	194150-36651	2	2				
39- 32	PIPE 8x380, vinyl	194282-36660	2	2	10			
39- 33	GEAR w/COUNTERSHAFT	194287-31400			1			
39- 34	.COUNTERSHAFT	*			1	*		Order GEAR w/COUNTERSHAFT (194287-31410)
39- 35	.GEAR, ring	*			1	*		Order GEAR w/COUNTERSHAFT (194286-31420)

Fig. 40 REAR AXLE HOUSING

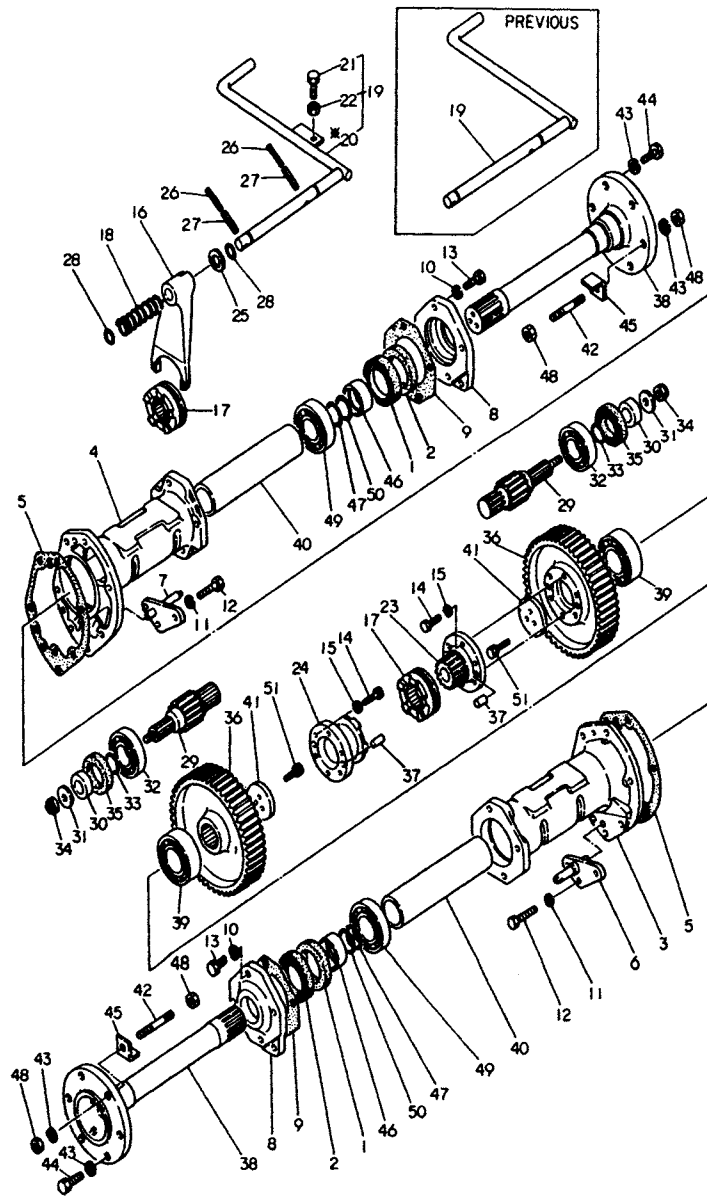

\* MARK PARTS: NOT SOLD SEPARATELY.

Fig. 40 REAR AXLE HOUSING

Refer. No.	Description	Part No.	Qty/Unit		Sales Unit	Interchangeability	Designchange Mark	Remarks
			YM241	YM241D				
40- 1	SEAL TC 60 75 9, oil	194321-13920	2	2				
40- 2	SEAL VC 60 75 6, oil	194321-13930	2	2				
40- 3	HOUSING(L), rear axle	X-194286-32610	1	1				
40- 4	HOUSING(R), rear axle	X-194286-32620	1	1				
40- 5	PACKING, axle housing	194150-32680	2	2	10			
40- 6	HINGE(L), lower link	194286-32810	1	1				
40- 7	HINGE(R), lower link	194286-32820	1	1				
40- 8	BRACKET, oil seal	X-194420-34310	2	2				
40- 9	PACKING, housing	194420-34340	2	2	10			
40- 10	SPRING WASHER 10	22217-100000	8	8	10			
40- 11	SPRING WASHER 10	22217-100000	2	2	10			
40- 12	BOLT M10x30	26116-100302	2	2	10			
40- 13	BOLT M10x35	26116-100352	8	8	10			
40- 14	BOLT M12x30	194274-13560	12	12	10			
40- 15	SPRING WASHER 12, lock	194274-13580	12	12	10			
40- 16	FORK, shift	194286-33110	1	1				
40- 17	SLIDER	194282-33120	1	1				
40- 18	SPRING, return	194150-33150	1	1	10			
40- 19	PEDAL, differential lock	X-194286-33150	1	1				Previous
	PEDAL ASS'Y, diff. lock	X-194286-33140	1	1		C		New Effective from YM241 -T/#20163 YM241D-T/#40154 Order ASS'Y (194286-33151)
40- 20	.PEDAL, differential lock	*	1	1	*			
40- 21	.BOLT M10x30	26116-100302	1	1	10			
40- 22	.NUT M10	26716-100002	1	1	10			
40- 23	FLANGE(A), differential	194286-33210	1	1				
40- 24	FLANGE(B), differential	194286-33220	1	1				

Fig. 40 REAR AXLE HOUSING

Refer. No.	Description	Part No.	Q'ty/Unit		Sales Unit	Interchangeability	Designchange Mark	Remarks
			YM241	YM241D				
40- 25	WASHER 20	22117-200000	1	1	10			
40- 26	SPRING PIN 5x40	22351-050040	2	2	10			
40- 27	SPRING PIN 8x40	22351-080040	2	2	10			
40- 28	O-RING 16-P	24311-000160	2	2	10			
40- 29	PINION, final reduction	194286-33410	2	2				
40- 30	SPACER 25x50x14	194286-33450	2	2				
40- 31	WASHER 13x36x6	194282-33480	2	2				
40- 32	BALL BEARING #6307UU	24104-063074	2	2				
40- 33	O-RING 29-P	24311-000290	2	2	10			
40- 34	U-NUT M12	26346-120002	2	2	10			
40- 35	SEAL TC 50 68 9, oil	194282-33460	2	2				
40- 36	GEAR, final reduction	194286-33550	2	2				
40- 37	PARALLEL PIN 16x22	22312-160220	4	4	10			
40- 38	SHAFT, real axle	X-194286-34120	2	2				
40- 39	BALL BEARING #5209	194282-34130	2	2				
40- 40	SPACER 57x240x5.2t	194286-34150	2	2				
40- 41	WASHER, rear axle	194282-34160	2	2				
40- 42	STUD M16x64	194286-34161	4	4				
40- 43	SPRING WASHER 16, lock	194280-34170	12	12	10			
40- 44	BOLT M16x35	194282-34180	8	8	10			
40- 45	SCRAPER	194286-34190	4	4				
40- 46	SLEEVE 45x60x19, oil seal	194286-34360	2	2				
40- 47	SPACER	194286-34390	2	2	10			
40- 48	NUT M16	194286-34830	8	8	10			
40- 49	BALL BEARING #6209	24101-062094	2	2				
40- 50	O-RING 45-G	24321-000450	2	2	10			
40- 51	BOLT M8x22	26013-080222	6	6	10			



Fig. 41 BRAKES

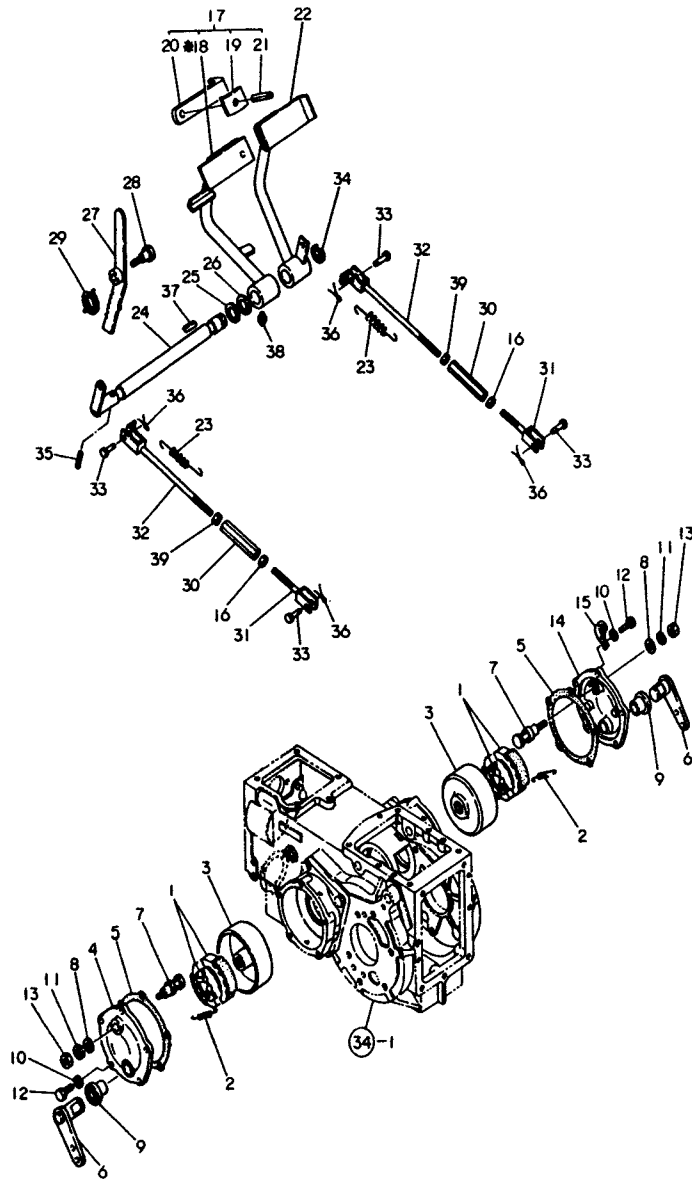

※ MARK PARTS: NOT SOLD SEPARATELY.

Fig. 41 BRAKES

Refer. No.	Description	Part No.	Q'ty/Unit		Sales Unit	Interchangeability	Designchange Mark	Remarks
			YMS41	YMS41D				
41- 1	SHOE, brake	194150-36511	4	4				
41- 2	SPRING, return	194150-36550	4	4	10			
41- 3	DRUM, brake	194150-36571	2	2				
41- 4	COVER(L), brake	X-194286-36610	1	1				
41- 5	PACKING, brake cover	194150-36630	2	2	10			
41- 6	CAMSHAFT, brake	X-194241-36710	2	2				
41- 7	ANCHOR PIN, brake	194150-36721	2	2				
41- 8	WASHER 10.5x26x3	194130-36730	2	2	10			
41- 9	BUSH	194286-36740	2	2	10			
41- 10	SPRING WASHER 8	22217-080000	10	10	10			
41- 11	SPRING WASHER 10	22217-100000	2	2	10			
41- 12	BOLT M8x25	26116-080252	10	10	10			
41- 13	NUT M10	26716-100002	2	2	10			
41- 14	COVER(R), brake	X-194286-36620	1	1				
41- 15	CLAMP(B)	194440-51620	1	1				
41- 16	NUT M10(LH screw)	194150-22480	2	2	10			
41- 17	PEDAL(L)ASS'Y, brake	X-194242-37420	1	1				
41- 18	.PEDAL(L), brake	*			*			Order ASS'Y (194150-37430)
41- 19	.SPACER, spring	194150-37530	1	1				
41- 20	.CONNECTOR	R-194145-37540	1	1				
41- 21	.SPRING PIN 8x18	22351-080018	1	1	10			
41- 22	PEDAL(R)	X-794150-37471	1					
41- 23	SPRING, return	194150-37510	2	2	10			
41- 24	SHAFT, brake pedal	X-194150-37551	1	1				
41- 25	WASHER, shaft	194130-37560	1	1	10			
41- 26	WASHER, shaft	1.2t 194150-37570	1	1	10			

Fig. 41 BRAKES

Refer. No.	Description	Part No.	Qty/Unit		Sales Unit	Interchange-ability	Designchange Mark	Remarks
			YM241	YM241D				
41- 27	LEVER, pedal lock	X-194150-37660	1	1				
41- 28	PIN, lock lever	194110-37673	1	1	10			
41- 29	SPRING, pedal lock	194110-37691	1	1				
41- 30	TURNBUCKLE M10x90	194151-37730	2	2				
41- 31	ROD(LH screw)	194130-37740	2	2				
41- 32	ROD(RH screw)	194151-37771	2	2				
41- 33	PIN 8x25	194080-37781	4	4	10			
41- 34	SNAP RING 19	22272-000190	1	1	10			
41- 35	SPRING PIN 6x40	22351-060040	1	1	10			
41- 36	COTTER PIN 2x30	22417-200300	4	4	10			
41- 37	KEY 7x7x40	22512-070400	1	1	10			
41- 38	GREASE NIPPLE M6F	24761-010000	1	1	10			
41- 39	NUT M10	26716-100002	2	2	10			

Fig. 42 HYDRAULIC PIPES

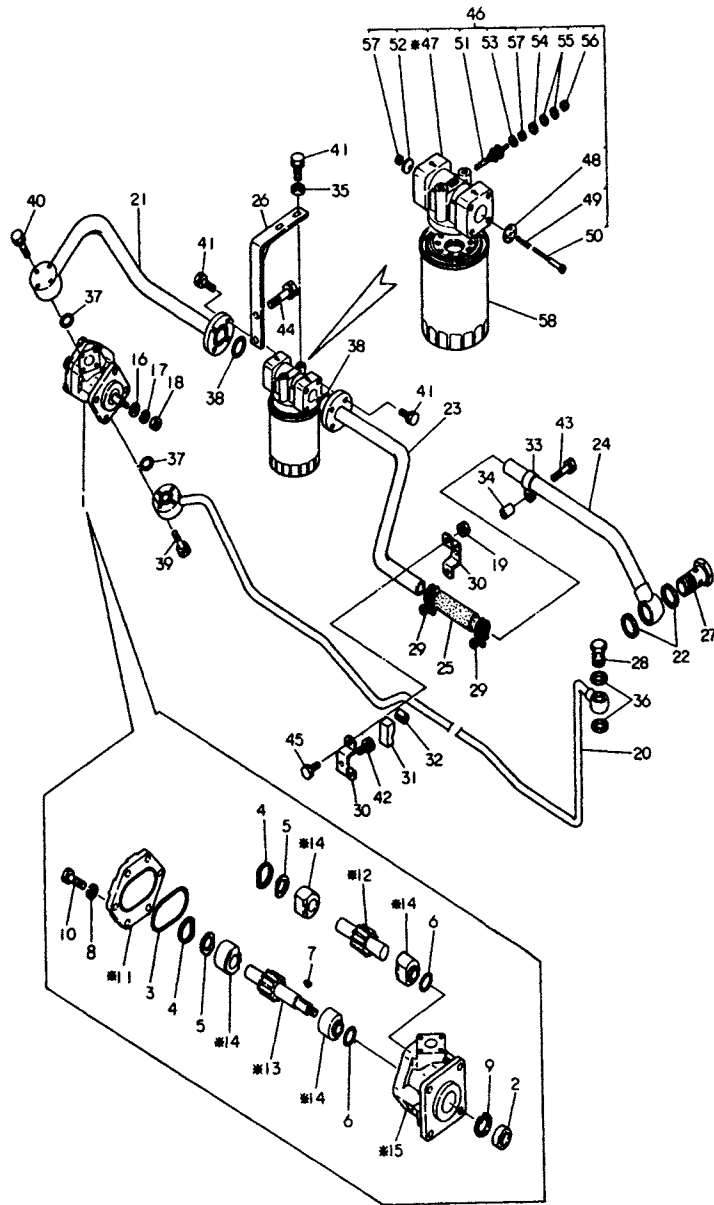

※ MARK PARTS: NOT SOLD SEPARATELY.

Fig. 42 HYDRAULIC OIL PIPES

Refer. No.	Description	Part No.	Q'ty/Unit		Sales Unit	Interchangeability	Designchange Mark	Remarks
			VM241	VM241D				
42- 1	PUMP ASS'Y, hydraulic	X-194242-41120	1	1				
42- 2	.SEAL, oil	194432-41150	1	1	10			
42- 3	.O-RING	194200-41170	1	1	10			
42- 4	.RING, sealing	194200-41180	2	2				
42- 5	.RING, support	194200-41190	2	2				
42- 6	.O-RING	194200-41200	2	2	10			
42- 7	.WOODRUFF KEY	194432-41210	1	1	10			
42- 8	.SPRING WASHER 8	22217-080000	6	6	10			
42- 9	.CIRCLIP 28-H	22252-000280	1	1	10			
42- 10	.BOLT M8x25	26126-080252	6	6	10			
42- 11	.COVER	*	1	1	*			Order ASS'Y (20011-11104)
42- 12	.GEAR, driven	*	1	1	*			Order ASS'Y (20011-10519)
42- 13	.GEAR, drive	*	1	1	*			Order ASS'Y (20011-10493)
42- 14	.BUSH	*	4	4	*			Order ASS'Y (20011-10331)
42- 15	.BODY	*	1	1	*			Order ASS'Y (20011-15190)
42- 16	WASHER 8.5x18x2	194100-41670	1	1	10			
42- 17	SPRING WASHER 8	22217-080000	1	1	10			
42- 18	NUT M8	194990-20180	1	1	10			
42- 19	NUT M6	194990-22130	2	2	10			
42- 20	PIPE, high pressure	X-194242-48110	1	1	10			
42- 21	PIPE, low pressure	X-194282-48150	1	1				
42- 22	PACKING 28	194167-48160	2	2	10			
42- 23	PIPE, low pressure	X-194283-48190	1	1				
42- 24	PIPE, low pressure	X-194150-48220	1	1				
42- 25	PIPE, low press. rubber	194150-48230	1	1				

Fig. 42 HYDRAULIC OIL PIPES

Refer. No.	Description	Part No.	Q'ty/Unit		Sales Unit	Interchangeability	Designation Mark	Remarks
			YM241	YM241D				
42- 26	BRACKET, filter	194286-48290	1	1				
42- 27	BOLT M28, pipe joint	194150-48600	1	1				
42- 28	BOLT M18, pipe joint	194130-48650	1	1	10			
42- 29	CLAMP, rubber pipe	194151-48710	2	2				
42- 30	CLAMP	194150-48821	2	2				
42- 31	RETAINER, pipe clamp	194150-48830	1	1				
42- 32	PROTECTOR, pipe clamp	194464-48850	1	1				
42- 33	CLAMP, low press. pipe	194150-48860	1	1				
42- 34	SPACER, pipe clamp	194150-48870	1	1				
42- 35	WASHER 8	22137-080000	2	2	10			
42- 36	PACKING 18	23414-180023	2	2	10			
42- 37	O-RING 20-P	24311-000200	2	2	10			
42- 38	O-RING 30-G	24321-000300	2	2	10			
42- 39	BOLT M6x35	26013-060352	4	4	10			
42- 40	BOLT M6x40	26013-060402	3	3	10			
42- 41	BOLT M8x20	26013-080202	10	10	10			
42- 42	BOLT M10x20	26013-100202	1	1	10			
42- 43	BOLT M10x38	26013-100382	1	1	10			
42- 44	BOLT M12x40	26013-120402	2	2	10			
42- 45	BOLT M6x16	26116-060162	2	2	10			

Fig. 42 HYDRAULIC OIL PIPES

Refer. No.	Description	Part No.	Q'ty/Unit		Sales Unit	Interchangeability	Designation Mark	Remarks
			YM241	YM241D				
42- 46	COVER ASS'Y, strainer	X-194286-48300	1	1				
42- 47	.COVER, strainer	*	1	1	*			Order ASS'Y (194286-48310)
42- 48	.BASE, valve	194286-48320	1	1				
42- 49	.SPRING, valve	194286-48330	1	1	10			
42- 50	.BOLT	194286-48340	1	1				
42- 51	.PLUG	194286-48350	1	1				
42- 52	.VALVE	194370-48350	1	1				
42- 53	.SEAT, insulator	194286-48360	1	1	10			
42- 54	.WASHER, lock	194286-48370	1	1	10			
42- 55	.WASHER 8	22137-080000	2	2	10			
42- 56	.NUT M4	26716-040002	1	1	10			
42- 57	.U-NUT M4	26346-040002	2	2	10			
42- 58	STRAINER	194370-48390	1	1				

Fig. 43 HYDRAULIC CYLINDER

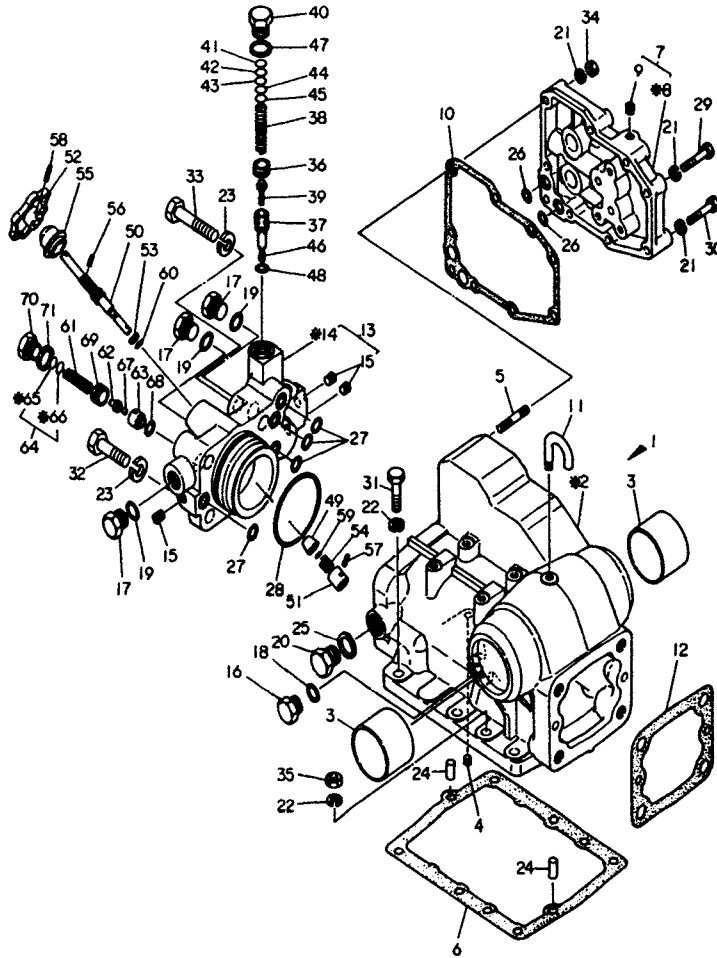

\* MARK PARTS: NOT SOLD SEPARATELY.

Fig. 43 HYDRAULIC CYLINDER

Refer. No.	Description	Part No.	Qty/Unit		Sales Unit	Interchangeability	Designchange Mark	Remarks
			YM241	YM341D				
43- 1	CASE ASS'Y, hyd. cyl.	X-194242-42100	1	1				
43- 2	.CASE, hyd. cyl.	*	1	1	*			Order ASS'Y (194242-42110)
43- 3	.BUSH 55x60x40	194170-42130	2	2				
43- 4	.TAPER PLUG PT1/8	23873-010000	1	1	10			
43- 5	.STUD M8x45	26216-080452	2	2	10			
43- 6	PACKING, hyd. cyl. case	194242-42150	1	1	10			
43- 7	CASE ASS'Y, cyl. side	X-194170-42200	1	1				
43- 8	.CASE, cyl. side	*	1	1	*			Order ASS'Y (194170-42210)
43- 9	.TAPER PLUG PT1/8	23873-010000	4	4	10			
43- 10	PACKING, side case	194170-42220	1	1				
43- 11	PIPE, breather	194150-42280	1	1				
43- 12	PACKING, hinge top link	194151-42831	1	1				
43- 13	HEAD ASS'Y, cylinder	X-194170-43200	1	1				
43- 14	.HEAD, cylinder	*	1	1	*			Order ASS'Y (194170-43210)
43- 15	.TAPER PLUG PT1/8	23873-010000	3	3				
43- 16	PLUG 3/4-16UNF	194464-45920	1	1				
43- 17	PLUG 3/4-16UNF	194464-45920	3	3				
43- 18	O-RING 8-1	194464-45930	1	1	10			
43- 19	O-RING 8-1	194464-45930	3	3	10			
43- 20	PLUG M18	194130-46750	1	1	10			
43- 21	SPRING WASHER 8	22217-080000	9	9	10			
43- 22	SPRING WASHER 10	22217-100000	8	8	10			
43- 23	SPRING WASHER 14	22217-140000	4	4	10			
43- 24	PARALLEL PIN 10x18	22312-100180	2	2	10			
43- 25	PACKING 18	23414-180023	1	1	10			

Fig. 43 HYDRAULIC CYLINDER

Refer. No.	Description	Part No.	Q'ty/Unit		Sales Unit	Interchange-ability	Designchange Mark	Remarks
			YM241	YM241D				
43- 26	O-RING 11-P	24315-000110	2	2	10			
43- 27	O-RING 14-P	24315-000140	4	4	10			
43- 28	O-RING 75-G	24325-000750	1	1	10			
43- 29	BOLT M8x35	26116-080352	1	1	10			
43- 30	BOLT M8x45	26116-080452	4	4	10			
43- 31	BOLT M10x35	26116-100352	3	3	10			
43- 32	BOLT M14x45	26126-140452	2	2	10			
43- 33	BOLT M14x65	26126-140652	2	2	10			
43- 34	NUT M8	26716-080002	4	4	10			
43- 35	NUT M10	26716-100002	5	5	10			
43- 36	SCREW, relief valve	194275-45340	1	1				
43- 37	SEAT, relief valve	194170-45600	1	1				
43- 38	SPRING, relief valve	194170-45610	1	1	10			
43- 39	HOLDER, relief valve	194170-45620	1	1				
43- 40	PLUG, relief valve	194170-45630	1	1				
43- 41	SHIM t=0.1	194170-45700	-	-	10			
43- 42	SHIM t=0.2	194170-45710	-	-	10			
43- 43	SHIM t=0.3	194170-45720	-	-	10			
43- 44	SHIM t=0.5	194170-45730	-	-	10			
43- 45	SHIM t=1.0	194170-45740	-	-	10			
43- 46	LOCK SCREW 7x8	1E6191-54330	1	1	10			
43- 47	PACKING 20	23414-200026	1	1	10			
43- 48	O-RING 12-P	24311-000120	1	1	10			
43- 49	VALVE, stop	194170-46300	1	1				
43- 50	BOLT, stop	194170-46620	1	1				

Selective

Fig. 43 HYDRAULIC CYLINDER

Refer. No.	Description	Part No.	Q'ty/Unit		Sales Unit	Interchange-ability	Designchange Mark	Remarks
			YM241	YM241D				
43- 51	HOLDER, valve	194170-46630	1	1				
43- 52	KNOB	X-194151-46640	1	1				
43- 53	RING, back-up	194170-46651	1	1				
43- 54	SPRING, return	194170-46660	1	1	10			
43- 55	CAP	194170-46670	1	1				
43- 56	SPRING PIN 4x16	22351-040016	1	1	10			
43- 57	SPRING PIN 4x16	22351-040016	1	1	10			
43- 58	SPRING PIN 4x22	22351-040022	1	1	10			
43- 59	O-RING 6-P	24311-000060	1	1	10			
43- 60	O-RING 9-P	24311-000090	1	1	10			
43- 61	SPRING, relief valve	194150-45320	1	1	10			
43- 62	HOLDER, relief valve	194150-45361	1	1				
43- 63	SEAT, relief valve	194151-46261	1	1				
43- 64	SHIM SET	110250-53150	1	1	10			
43- 65	.SHIM t=0.2	*	1	1	*			Order SHIM SET (110250-53410)
43- 66	.SHIM t=0.5	*	1	1	*			Order SHIM SET (110250-53430)
43- 67	BALL 1/4	24190-080003	1	1	10			
43- 68	O-RING 12-P	24311-000120	1	1	10			
43- 69	SCREW, relief valve	194150-45340	1	1				
43- 70	PLUG, relief valve	194151-45370	1	1				
43- 71	PACKING 20	23414-200026	1	1	10			

Fig. 44 HYDRAULIC LIFT

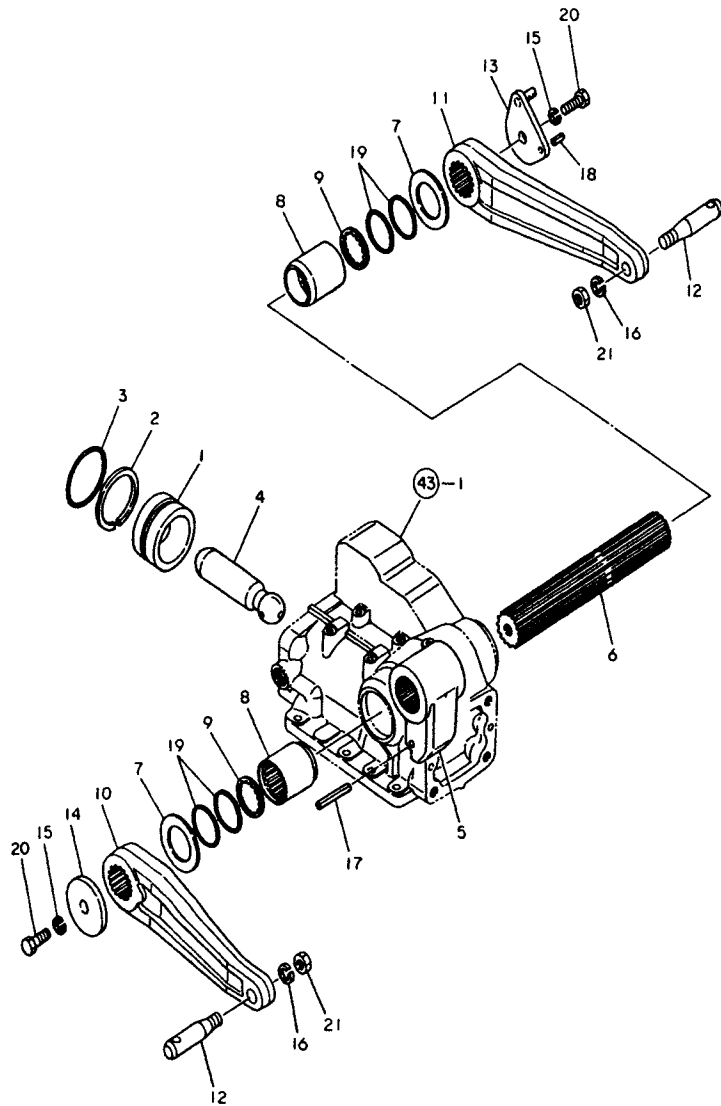
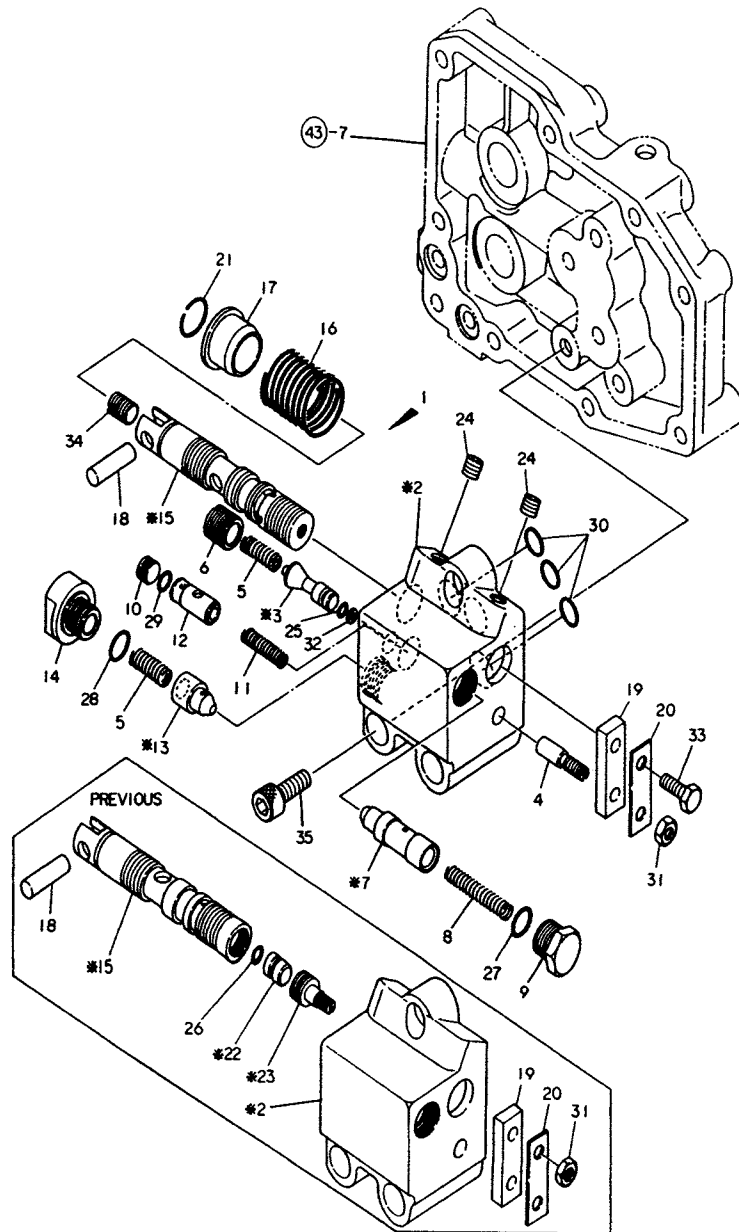

Fig. 44 HYDRAULIC LIFT

Refer. No.	Description	Part No.	Q'ty/Unit		Sales Unit	Interchangeability	Designation	Mark	Remarks
			YM241	YM241D					
44- 1	PISTON	194170-43310	1	1					
44- 2	RING 70-P, back-up	194130-43351	1	1					
44- 3	O-RING 70-P	24311-000700	1	1	10				
44- 4	ROD, piston	194170-43410	1	1					
44- 5	CRANK, lift	194170-44110	1	1					
44- 6	SHAFT, connecting	194170-44210	1	1					
44- 7	WASHER 45x73x3.2	194170-44230	2	2					
44- 8	SLEEVE, lifting shaft	194170-44250	2	2					
44- 9	SEAL, spline shaft	194170-44260	2	2					
44- 10	ARM(L), lift	X-194170-44420	1	1					
44- 11	ARM(R), lift	X-194170-44430	1	1					
44- 12	PIN, lift arm	194130-44480	2	2					
44- 13	ARM, feed back	X-194170-44510	1	1					
44- 14	RETAINER, shaft	X-194370-44520	1	1					
44- 15	SPRING WASHER 12	22217-120000	2	2	10				
44- 16	SPRING WASHER 16	22217-160000	2	2	10				
44- 17	SPRING PIN 5x56	22351-050056	1	1	10				
44- 18	SPRING PIN 6x16	22351-060016	1	1	10				
44- 19	O-RING 55-G	24321-000550	4	4	10				
44- 20	BOLT M12x28	26116-120282	2	2	10				
44- 21	NUT M16	26736-160002	2	2	10				

Fig. 45 HYDRAULIC CONTROL VALVE



MARK PARTS: NOT SOLD SEPARATELY.

Fig. 45 HYDRAULIC CONTROL VALVE

Refer. No.	Description	Part No.	Q'ty/Unit		Sales Unit	Interchangeability	Designchange Mark	Remarks
			YM341	YM341D				
45- 1	VALVE ASS'Y, control	194170-45100	1	1				
45- 2	.BODY, valve	*	1	1	*			Order ASS'Y (194170-45110)
	.BODY, valve	*	1	1	*	B		Order ASS'Y (194170-45111)
45- 3	.POPPET	*	1	1	*			Order ASS'Y (194170-45210)
	.POPPET	*	1	1	*	B		Order ASS'Y (194170-45211)
45- 4	.BAR, push	194170-45220	1	1				
45- 5	.SPRING, LM check	194170-45230	2	2	10			
45- 6	.HOLDER	194170-45250	1	1				
45- 7	.POPPET	*	1	1	*			Order ASS'Y (194170-45310)
45- 8	.SPRING, unload	194170-45320	1	1	10			
45- 9	.PLUG	194170-45330	1	1				
45- 10	.SPOOL	194170-45350	1	1				
45- 11	.SPRING	194170-45360	1	1	10			
45- 12	.PLUG	194170-45370	1	1				
45- 13	.POPPET	*	1	1	*			Order ASS'Y (194170-45420)
45- 14	.PLUG	194170-45440	1	1				
45- 15	.SPOOL	*	1	1	*			Order ASS'Y (194170-45510)
45- 16	.SPRING, spool	194170-45520	1	1				
45- 17	.STOPPER, spool	194170-45530	1	1				
45- 18	.PIN	194170-45540	1	1				
45- 19	.BAR	194170-45550	1	1				
45- 20	.WASHER 12x40x0.6	194170-45560	1	1				
45- 21	.CIRCLIP	194170-45570	1	1				
45- 22	.PLUG, spool	*	1	1	*	D		Order ASS'Y (194170-45580)
45- 23	.STUD M6x12	*	1	1	*	D		Order ASS'Y (194170-45590)



Fig. 45 HYDRAULIC CONTROL VALVE

Refer. No.	Description	Part No.	Qty/Unit		Sales Unit	Interchangeability	Designchange Mark	Remarks
			YM241	YM241D				
45- 24	.TAPER PLUG FT1/8	23873-010000	2	2	10			
45- 25	.O-RING 5-P	24311-000050	1	1	10			
45- 26	.O-RING 5-P	24311-000050	1	1	10	D		Previous
45- 27	.O-RING 12-P	24311-000120	1	1	10			
45- 28	.O-RING 12-P	24311-000120	1	1	10			
45- 29	.O-RING 7-P	24315-000070	1	1	10			
45- 30	.O-RING 11-P	24315-000110	3	3	10			
45- 31	.LOCK NUT M6	26756-060002	2	2	10			Previous
	.LOCK NUT M6	26756-060002	1	1	10	b		
45- 32	.RING, back-up	194170-45430	1	1				
45- 33	.BOLT M6x14	26116-060142	1	1	10	E		
45- 34	.PLUG, spool	194170-45410	1	1		E		
45- 35	BROACHED BOLT M8x20	26450-080202	3	3	10			

Fig. 46 OIL PRESSURE CONTROL

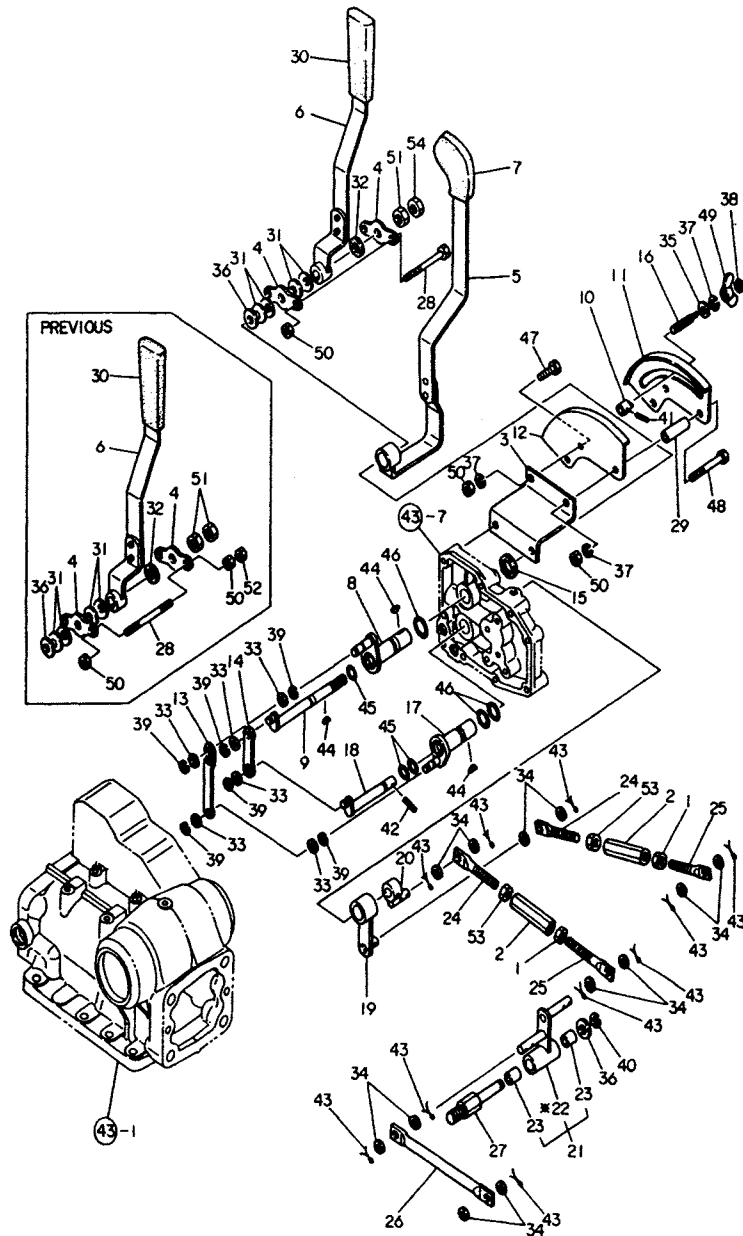

\* MARK PARTS: NOT SOLD SEPARATELY.

Fig. 46 OIL PRESSURE CONTROL

Refer. No.	Description	Part No.	Q'ty/Unit		Sales Unit	Interchangeability	Designation Mark	Remarks
			YM241	YM241D				
46- 1	NUT M10 (LH screw)	194150-22480	2	2	10			
46- 2	TURNBUCKLE M10x70	194130-37730	2	2				
46- 3	BRACKET	X-194170-47310	1	1				
46- 4	PLATE	X-194170-47320	2	2				
46- 5	LEVER, position control	X-194170-47360	1	1				
46- 6	LEVER, draft control	X-194170-47370	1	1				
46- 7	KNOB, lever	194420-47370	1	1				
46- 8	SHAFT, position control	194170-47380	1	1				
46- 9	SHAFT, draft control	194170-47390	1	1				
46- 10	STOPPER	194450-47390	1	1				
46- 11	GUIDE, position control	X-194170-47400	1	1				
46- 12	GUIDE, draft control	X-194170-47410	1	1				
46- 13	BAR, position control	194170-47420	1	1				
46- 14	BAR, draft control	194170-47430	1	1				
46- 15	PLATE, friction	194170-47440	1	1				
46- 16	BOLT, stopper	194464-47440	1	1				
46- 17	SHAFT, feed back	194170-47450	1	1				
46- 18	SHAFT, feed back	194170-47460	1	1				
46- 19	ARM, feed back	194170-47470	1	1				
46- 20	ARM, feed back	194170-47480	1	1				
46- 21	ARM w/BUSH	194170-47490	1	1				
46- 22	.ARM	*	1	1	*			Order ARM w/BUSH (194170-47500)
46- 23	.BUSH 12x15	24550-012150	2	2				

Fig. 46 OIL PRESSURE CONTROL

Refer. No.	Description	Part No.	Qty/Unit		Sales Unit	Interchangeability	Designchange Mark	Remarks
			YM241	YM241D				
46- 24	ROD(A), feed back	194180-47490	2	2				
46- 25	ROD(B), feed back	194180-47500	2	2				
46- 26	ROD(C), feed back	X-194170-47510	1	1				
46- 27	STUD	194170-47520	1	1				
46- 28	STUD M8x90	194170-47530	2	2	10			
	BOLT M8x70	26116-080702	2	2	10	B	Effective from YM241 -T/#20154 YM241D-T/#40133	
46- 29	SPACER, guide	194170-47540	2	2				
46- 30	KNOB, lever	194150-47621	1	1				
46- 31	SPRING WASHER 12	194151-47760	4	4	10			
46- 32	PLATE, friction	194310-47790	1	1	10			
46- 33	WASHER 8	22117-080000	6	6	10			
46- 34	WASHER 10	22117-100000	12	12	10			
46- 35	WASHER 8	22137-080000	1	1	10			
46- 36	WASHER 12	22137-120000	2	2	10			
46- 37	SPRING WASHER 8	22217-080000	4	4	10			
46- 38	SNAP RING 4	22272-000040	1	1	10			
46- 39	SNAP RING 6	22272-000060	6	6	10			
46- 40	SNAP RING 9	22272-000090	1	1	10			
46- 41	SPRING PIN 4x14	22351-040014	1	1	10			
46- 42	SPRING PIN 5x25	22351-050025	1	1	10			

Fig. 46 OIL PRESSURE CONTROL

Refer. No.	Description	Part No.	Qty/Unit		Sales Unit	Interchangeability	Designchange Mark	Remarks
			YM241	YM241D				
46- 43	COTTER PIN 3x20	22417-300200	10	10	10			
46- 44	WOODRUFF KEY 3x13	22522-030130	3	3	10			
46- 45	O-RING 9-P	24311-000090	3	3	10			
46- 46	O-RING 15-P	24311-000150	3	3	10			
46- 47	BOLT M8x18	26116-080182	1	1	10			
46- 48	BOLT M8x60	26116-080602	2	2	10			
46- 49	WING NUT M8	26635-080002	1	1	10			
46- 50	NUT M8	26716-080002	7	7	10			
	NUT M8	26716-080002	5	5	10	b	\$	
46- 51	NUT M12	26716-120002	2	2	10			
	NUT M12	26716-120002	1	1	10	b	\$	
46- 52	LOCK NUT M8	26756-080002	2	2	10	D	\$	
46- 53	LOCK NUT M10	26756-100002	2	2	10			
46- 54	NUT M12	26726-120002	1	1	10	E	\$	

Remarks: \$-marked parts changed from July, 1981. Effective from T/#20154 for YM241, T/#40133 for YM241D.

Fig. 47 DRAFT CONTROL

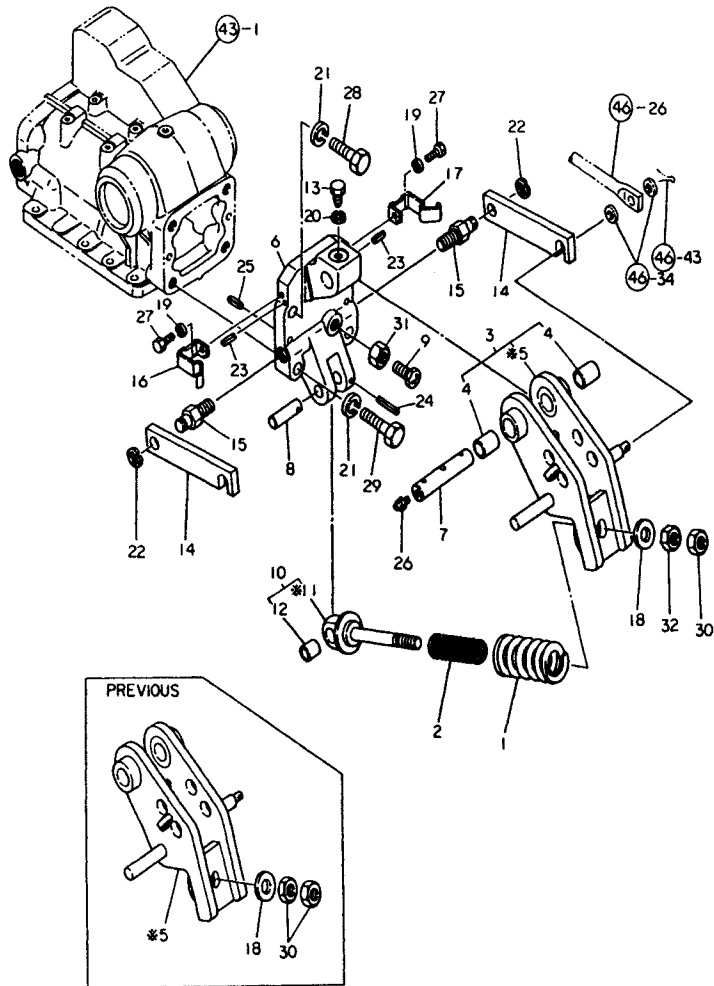

※ MARK PARTS: NOT SOLD SEPARATELY.

Fig. 47 DRAFT CONTROL

Refer. No.	Description	Part No.	Qty/Unit		Sales Unit	Interchangeability	Designchange Mark	Remarks
			YM241	YM241D				
47- 1	SPRING(A)	194170-47710	1	1				
		194242-47710	1	1		C	Effective from YM241 -T/#20201 YM241D-T/#40195	
47- 2	SPRING(B) SPRING(B)	194170-47720	1	1				
		194170-47720	1	1		D	Effective from YM241 -T/#20201 YM241D-T/#40195	
47- 3	HINGE ASS'Y, top link	X-194170-47730	1	1				
47- 4	.BUSH	194190-11520	2	2				
47- 5	.HINGE	*	1	1	*			Order ASS'Y (194170-47750)
47- 6	COVER, rear	X-194170-47740	1	1				
47- 7	PIN 22	194320-47760	1	1				
47- 8	PIN(B), hinge	194170-47770	1	1				
47- 9	STOPPER, hinge	194170-47780	1	1				
47- 10	BOLT w/BUSH	X-194170-47800	1	1				
47- 11	.BOLT	*	1	1	*			Order BOLT w/BUSH (194170-47810)
47- 12	.BUSH 18x20	24550-018200	1	1	10			
47- 13	LOCK BOLT M10	194320-47860	1	1	10			
47- 14	BAR, lock	X-194322-47910	2	2				
47- 15	BOLT, fulcrum	194322-47920	2	2				
47- 16	SPRING(L), lock bar	X-194322-47930	1	1				
47- 17	SPRING(R), lock bar	X-194322-47940	1	1				
47- 18	WASHER	1A1104-53200	1	1	10			
47- 19	SPRING WASHER 6	22217-060000	2	2	10			
47- 20	SPRING WASHER 10	22217-100000	1	1	10			
47- 21	SPRING WASHER 14	22217-140000	4	4	10			
47- 22	SNAP RING 12	22272-000120	2	2	10			

Fig. 47 DRAFT CONTROL

Refer. No.	Description	Part No.	Qty/Unit		Sales Unit	Interchangeability	Designchange Mark	Remarks
			YM241	YM241D				
47- 23	SPRING PIN 3x12	22351-030012	2	2	10			
47- 24	SPRING PIN 5x36	22351-050036	1	1	10			
47- 25	SPRING PIN 10x20	22351-100020	2	2	10			
47- 26	GREASE NIPPLE M6F	24764-010000	1	1	10			
47- 27	BOLT M6x8	26116-060082	2	2	10			
47- 28	BOLT M14x45	26126-140452	2	2	10			
47- 29	BOLT M14x55	26126-140552	2	2	10			
47- 30	NUT M14	26726-140002	2	2	10			
	NUT M14	26726-140002	1	1	10	b		Effective from YM241 -T/#20154 YM241D-T/#40133
47- 31	NUT M14	26726-140002	1	1	10			
47- 32	NUT M14	26716-140002	1	1	10			

Fig. 48 ELECTRIC PARTS

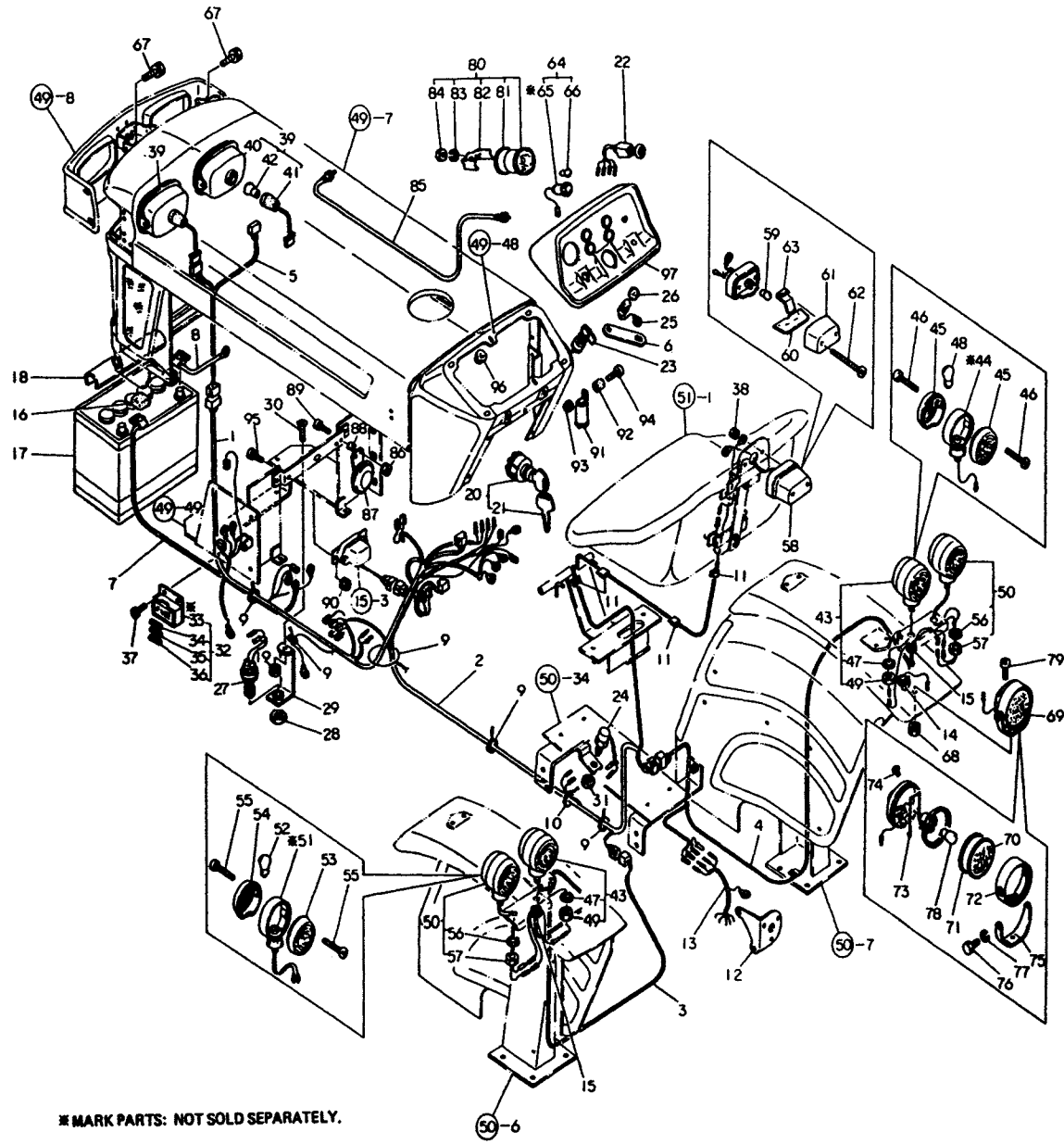

\* MARK PARTS: NOT SOLD SEPARATELY.

Nov., 1981

  
TO BE CONTINUED

Fig. 48 ELECTRIC PARTS

Refer. No.	Description	Part No.	Q'ty/Unit		Sales Unit	Interchange-ability	Designchange Mark	Remarks
			YM241	YM241D				
48- 1	HARNES(A), wire	194242-51110	1	1				
48- 2	HARNES(B), wire	194242-51120	1	1				
48- 3	HARNES(C), wire	194242-51130	1	1				
48- 4	HARNES(D), wire	194242-51140	1	1				
48- 5	HARNES(E), wire	194155-51151	1	1				
48- 6	PLATE, earth	194440-51180	1	1				
48- 7	CABLE, battery	194420-51410	1	1				
48- 8	CABLE, battery earth	194190-51420	1	1				
48- 9	WIRE	194150-51620	5	5	10			
48- 10	WIRE	194150-51620	1	1	10			
48- 11	CLAMP(D), binding	194242-51660	4	4				
48- 12	BRACKET, socket	194240-51701	1	1				
48- 13	HARNES, socket	194242-51820	1	1				
48- 14	GROMMET 8	194080-58810	1	1	10			
48- 15	GROMMET 8	194080-58810	2	2	10			
48- 16	RUBBER, insulating	194080-51430	1	1				
48- 17	BATTERY N70Z-TP	194240-51501	1	1				
48- 18	COVER, battery fluid inlet	194150-51550	1	1				
48- 19	NUT M8	194990-22050	1	1	10			
48- 20	SWITCH, main	194155-52110	1	1				
48- 21	.KEY, main switch	194155-52190	1	1	10			
48- 22	SWITCH, light	194240-52120	1	1				
48- 23	SWITCH, warning light	194440-52130	1	1				
48- 24	SWITCH, stop lamp	194450-52150	1	1				
48- 25	SWITCH, horn	194150-52160	1	1				
48- 26	CAP, horn switch	194150-52170	1	1				

Fig. 48 ELECTRIC PARTS

Refer. No.	Description	Part No.	Q'ty/Unit		Sales Unit	Interchange-ability	Designchange Mark	Remarks
			YM241	YM241D				
48- 27	SWITCH, safety start	194440-52190	1	1				
48- 28	NUT M22	194240-52210	1	1				
48- 29	STAY, start switch	194240-52220	1	1				
48- 30	SCREW M8x20	26577-080202	1	1	10			
48- 31	LOCK NUT M12	26776-120002	1	1	10			
48- 32	BOX ASS'Y, fuse	194145-52400	1	1				
	BOX ASS'Y, fuse	194440-52400	1	1		A		
48- 33	.BOX, fuse	*	1	1	*			Order ASS'Y (194145-52410)
	.BOX, fuse	*	1	1	*	B		Order ASS'Y (194440-52410)
48- 34	.FUSE 5A	194145-52820	1	1	10			
48- 35	.FUSE 10A	194145-52830	2	2	10			
48- 36	.FUSE 15A	194145-52840	2	2	10			
48- 37	SCREW M6x20	26587-060202	2	2	10			
48- 38	NUT M5	194990-22030	2	2	10			
48- 39	LIGHT ASS'Y, head	194155-53100	2	2				
48- 40	.LIGHT UNIT	194155-53110	2	2				
48- 41	.SOCKET	194155-53120	2	2				
48- 42	.BULB 12V 35/25W	194155-55810	2	2	10			
48- 43	LIGHT ASS'Y, warning	194242-53400	2	2				
48- 44	.BODY, warning light	*	2	2	*			Order ASS'Y (194242-53410)
48- 45	.LENS	194242-55420	4	4				
48- 46	.SCREW	194242-55430	8	8	10			
48- 47	.WASHER 12, fluted	194242-55440	2	2	10			
48- 48	.BULB 12V 20W	194081-55820	2	2	10			
48- 49	.LOCK NUT M12	26786-120002	2	2	10			

Fig. 48 ELECTRIC PARTS

Refer. No.	Description	Part No.	Q'ty/Unit		Sales Unit	Interchange-ability	Designchange Mark	Remarks
			YM241	YM241D				
48- 50	LAMP ASS'Y, stop	194242-53600	2	2				
48- 51	.BODY, stop lamp	*	2	2	*		Order ASS'Y (194242-53610)	
48- 52	.BULB 12V 21/5W	194242-53620	2	2	10			
48- 53	.LENS(red)	194242-53630	2	2				
48- 54	.LENS(clear)	194242-53640	2	2				
48- 55	.SCREW	194242-55430	8	8	10			
48- 56	.WASHER 12, fluted	194242-55440	2	2	10			
48- 57	.LOCK NUT M12	26786-120002	2	2	10			
48- 58	LIGHT ASS'Y, license plate	194450-53800	1	1				
48- 59	.BULB 12V 10W	194450-53810	1	1	10			
48- 60	.LENS	194450-53820	1	1				
48- 61	.COVER	194450-53830	1	1				
48- 62	.SCREW M5x70	194450-53870	2	2	10			
48- 63	.SHADE	194450-53880	1	1				
48- 64	INDICATOR ASS'Y	194440-55100	4	4				
48- 65	.SOCKET	*	4	4	*		Order ASS'Y (194440-55120)	
48- 66	.BULB 12V 3.4W	194440-55820	4	4	10			
48- 67	BOLT M10x16	26013-100162	4	4	10			
48- 68	NUT M8	194990-22050	1	1	10			
48- 69	LIGHT ASS'Y, work	794081-54101	1	1				
48- 70	.LENS, work light	194081-54110	1	1				
48- 71	.GASKET, lens	194081-54120	1	1	10			
48- 72	.RIM	194081-54131	1	1				
48- 73	.SPRING	194081-54151	3	3	10			

Fig. 48 ELECTRIC PARTS

Refer. No.	Description	Part No.	Q'ty/Unit		Sales Unit	Interchange-ability	Designchange Mark	Remarks
			YM241	YM241D				
48- 74	.SCREW	194081-54210	1	1	10			
48- 75	.STAY	194081-54221	1	1				
48- 76	.BOLT M6x12	194081-54230	2	2	10			
48- 77	.SPRING WASHER 6	194081-54240	2	2	10			
48- 78	.BULB 12V 20W	194081-55820	1	1	10			
48- 79	SCREW M8x16	26587-080162	1	1	10			
48- 80	HOUR-METER	194286-56100	1	1				
48- 81	.SHEET	194110-56150	1	1	10			
48- 82	.FITTINGS	194110-56170	1	1				
48- 83	.SPRING WASHER 4	22217-040000	2	2	10			
48- 84	.NUT M4	26716-040002	2	2	10			
48- 85	CABLE, hour-meter	194167-56900	1	1				
48- 86	NUT M6	194990-22040	2	2	10			
48- 87	HORN	194151-57100	1	1				
48- 88	SPACER	194151-63250	2	2	10			
48- 89	SCREW M6x30	26557-060302	2	2	10			
48- 90	NUT M6	194990-22040	2	2	10			
48- 91	RELAY, flasher	194080-57202	1	1				
48- 92	SPACER	194151-57210	1	1	10			
48- 93	U-NUT M5	26346-050002	1	1	10			
48- 94	SCREW M5x16	26557-050162	1	1	10			
48- 95	SCREW M6x12	26557-060122	2	2	10			
48- 96	NUT M5	194990-22120	6	6	10			
48- 97	PANEL, dash-board	194286-61610	1	1				



Fig. 49 HOOD

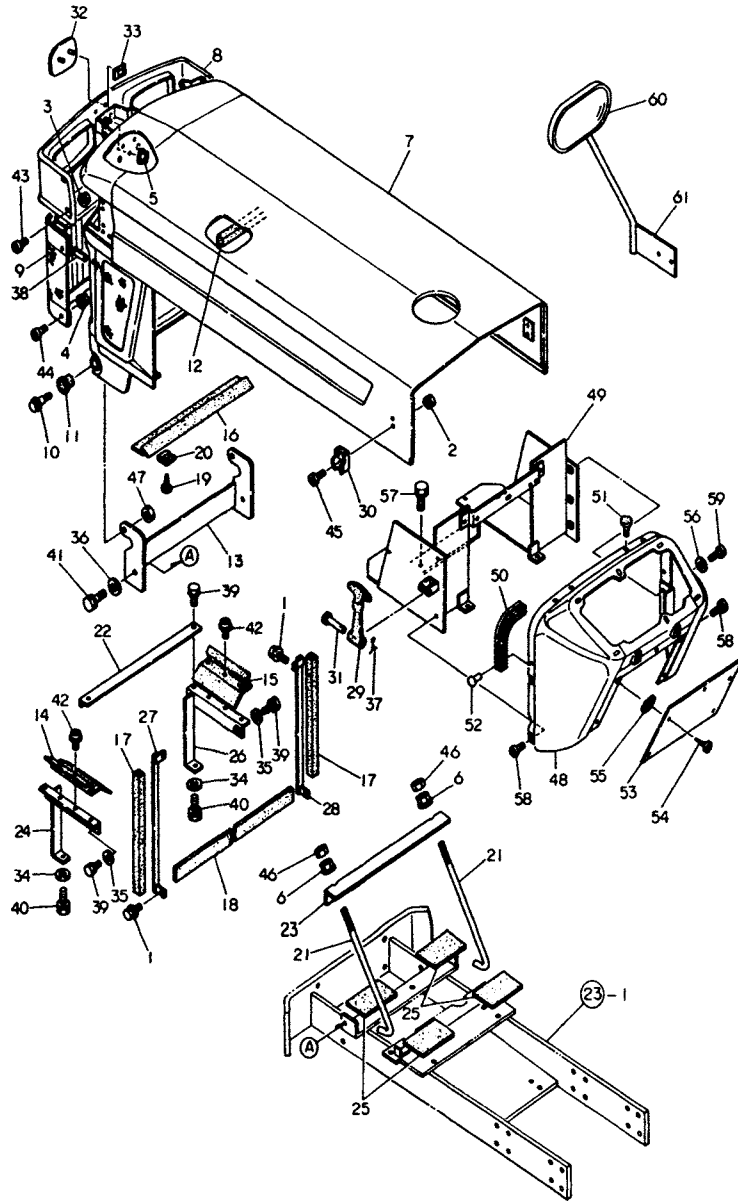

Fig. 49 HOOD

Refer. No.	Description	Part No.	Q'ty/Unit		Sales Unit	Interchangeability	Designchange Mark	Remarks
			YM241	YM241D				
49- 1	BOLT M6x16	194155-05210	4	4	10			
49- 2	NUT M5	194990-22030	4	4	10			
49- 3	NUT M5	194990-22120	4	4	10			
49- 4	NUT M5	194990-22120	6	6	10			
49- 5	NUT M6	194990-22130	1	1	10			
49- 6	NUT M8	194990-22140	2	2	10			
49- 7	HOOD	P-194286-61100	1	1				
49- 8	PANEL, hood(upper)	P-194286-61160	1	1				
49- 9	GRILLE, front	P-194167-61210	1	1				
49- 10	BOLT, hood hinge	194155-61241	2	2				
49- 11	BUSH, hood hinge	194155-61251	2	2	10			
49- 12	PAD(C)	194322-61260	1	1	10			
49- 13	HINGE, hood	X-194167-61320	1	1				
49- 14	RUBBER(AL), sealed	194287-61410	1	1	10			
49- 15	RUBBER(AR), sealed	194286-61430	1	1	10			
49- 16	RUBBER(B), sealed	194286-61440	1	1	10			
49- 17	RUBBER(C), sealed	194286-61450	2	2	10			
49- 18	RUBBER(D), sealed	194286-61460	1	1	10			
49- 19	SCREW M5x16	194420-61640	5	5	10			
49- 20	NUT M5	194145-61650	5	5	10			
49- 21	ROD, battery clamp	194190-61740	2	2				
49- 22	STAY, front	X-194286-61740	1	1				
49- 23	CLAMP, battery	194190-61750	1	1				
49- 24	PLATE(L), side	X-194287-61750	1	1				
49- 25	RUBBER, cushion	194190-61761	4	4	10			

Fig. 49 HOOD

Refer. No.	Description	Part No.	Qty/Unit		Sales Unit	Interchangeability	Designation Mark	Remarks
			YM241	YM241D				
49- 26	PLATE(R), side	X-194287-61760	1	1				
49- 27	SUPPORT(L), rubber	194286-61770	1	1				
49- 28	SUPPORT(R), rubber	194286-61780	1	1				
49- 29	LOCK, hood	194080-61810	2	2				
49- 30	CATCH, hood lock	194080-61820	2	2				
49- 31	PIN, hood lock	194080-61840	2	2				
49- 32	EMBLEM, front	194200-65601	1	1	10			
49- 33	NUT 5	194200-65610	2	2	10			
49- 34	WASHER 10	22137-100000	2	2	10			
49- 35	WASHER 6	22157-060000	2	2	10			
49- 36	WASHER 10	22157-100000	2	2	10			
49- 37	COTTER PIN 2x12	22417-200120	2	2	10			
49- 38	PIPE 7x35	23061-070035	3	3	10			Vinyl
49- 39	BOLT M6x16	26013-060162	4	4	10			
49- 40	BOLT M10x16	26013-100162	2	2	10			
49- 41	BOLT M10x25	26013-100252	2	2	10			
49- 42	SCREW M5x12	26021-050122	6	6	10			
49- 43	SCREW M5x12	26557-050122	4	4	10			
49- 44	SCREW M5x12	26557-050122	6	6	10			
49- 45	SCREW M5x12	26557-050122	4	4	10			
49- 46	NUT M8	26716-080002	2	2	10			
49- 47	NUT M12	26716-120002	2	2	10			
49- 48	BOX, panel	P-194167-61500	1	1				
49- 49	BRACKET, panel box	X-194286-61530	1	1				
49- 50	PACKING, panel box	194440-61550	2	2				

Nov., 1981

- 173 -

Nov., 1981

Fig. 49 HOOD

Refer. No.	Description	Part No.	Qty/Unit		Sales Unit	Interchangeability	Designation Mark	Remarks
			YM241	YM241D				
49- 51	RUBBER, cushion	194145-61560	2	2	10			
49- 52	RIVET 5x6	194190-61560	4	4	10			
49- 53	COVER, panel box	P-194167-61620	1	1				
49- 54	SCREW M5x16	194420-61640	5	5	10			
49- 55	NUT M5	194145-61650	5	5	10			
49- 56	WASHER 8	22137-080000	2	2	10			
49- 57	BOLT M10x20	26013-100202	2	2	10			
	BOLT M10x20	26116-100202	2	2	10	A		
49- 58	SCREW M6x16	26587-060162	3	3	10			
	BOLT M6x12	26011-060122	3	3	10	A		
49- 59	SCREW M8x16	26587-080162	2	2	10			
49- 60	MIRROR, rear-view	194145-64100	1	1				
49- 61	STAY, rear-view mirror	194242-64120	1	1				
49- 62	WASHER 10	22137-100000	2	2	10	E		
	WASHER 10	194145-04810	2	2	10	C		Effective from YM241 -T/#20201 YM241D-T/#40195
49- 63	SPRING WASHER 10	22217-100000	2	2	10	E		

Nov., 1981

- 174 -

Nov., 1981

Fig. 50 FENDER

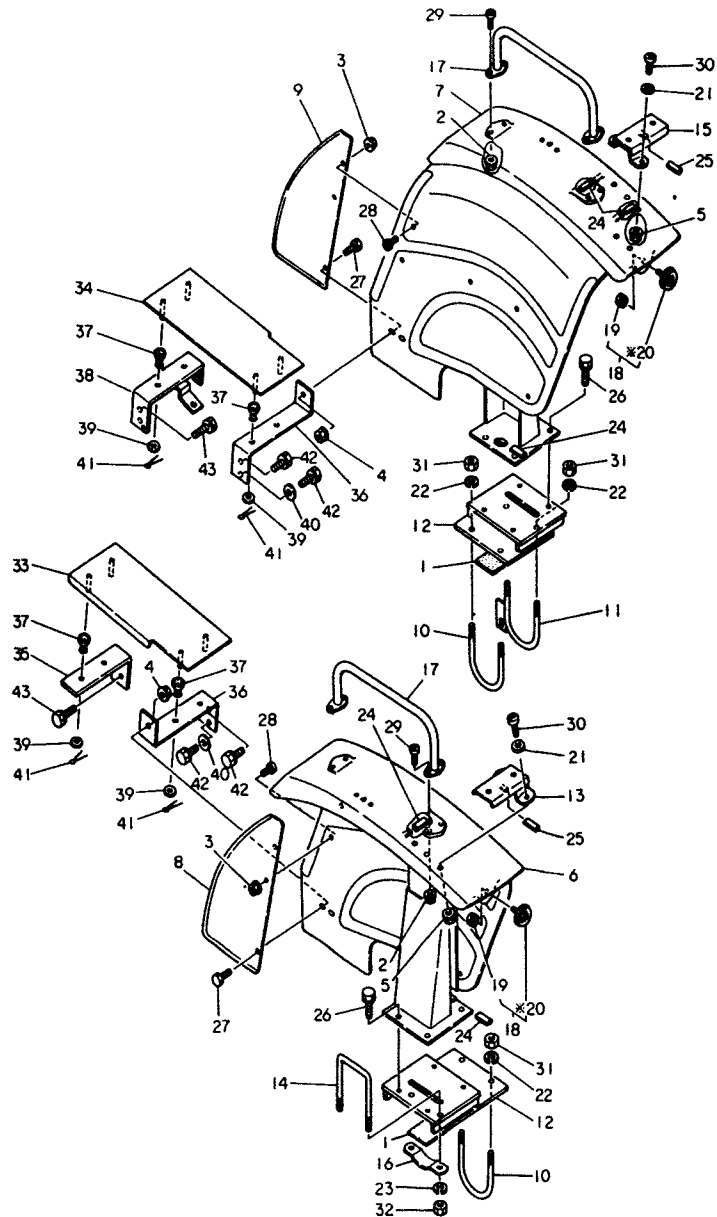

MARK PARTS: NOT SOLD SEPARATELY.

Fig. 50 FENDER

Refer. No.	Description	Part No.	Q'ty/Unit		Sales Unit	Interchangeability	Designchange Mark	Remarks
			YM241	YM241D				
50- 1	PACKING	194151-04260	2	2				
50- 2	NUT M6	194990-22130	8	8	10			
50- 3	NUT M6	194990-22130	4	4	10			
50- 4	NUT M8	194990-22140	2	2	10			
50- 5	NUT M8	194990-22140	4	4	10			
50- 6	FENDER(L)	P-194242-62110	1	1				
50- 7	FENDER(R)	P-194242-62120	1	1				
50- 8	SUB-FENDER(L)	P-194151-62130	1	1				
50- 9	SUB-FENDER(R)	P-194151-62140	1	1				
50- 10	U-BOLT M10	194150-62210	2	2				
50- 11	U-BOLT M10	194242-62210	1	1				
50- 12	SUPPORT, fender	X-194240-62221	2	2				
50- 13	STAY(L), warning light	P-194242-62220	1	1				
50- 14	U-BOLT M10	194240-62230	1	1				
50- 15	STAY(R), warning light	P-194242-62230	1	1				
50- 16	U-BOLT	194240-62240	1	1				
50- 17	BAR, assist	194740-70270	2	2				
50- 18	REFLECTOR ASS'Y	194740-76200	2	2				
50- 19	NUT M5	194990-22030	2	2	10			
50- 20	REFLECTOR		2	2	*			Order ASS'Y (194740-76210)
50- 21	WASHER 8	22137-080000	4	4	10			
50- 22	SPRING WASHER 10	22217-100000	6	6	10			
50- 23	SPRING WASHER 10	22217-100000	2	2	10			
50- 24	PIPE 7x35	23061-070035	5	5	10			Vinyl
50- 25	PIPE 7x35	23061-070035	2	2	10			Vinyl

Fig. 50 FENDER

Refer. No.	Description	Part No.	Qty/Unit		Sales Unit	Interchangeability	Designchange Mark	Remarks
			YM341	YM341D				
50- 26	BOLT M10x20	26013-100202	8	8	10			
50- 27	BOLT M8x20	26116-080202	2	2	10			
50- 28	SCREW M6x12	26557-060122	4	4	10			
50 -29	SCREW M6x16	26587-060162	8	8	10			
50- 30	SCREW M8x12	26587-080122	4	4	10			
50- 31	NUT M10	26716-100002	6	6	10			
50- 32	NUT M10	26716-100002	2	2	10			
50- 33	STEP (L)	X-194150-62512	1	1				
50- 34	STEP (R)	X-194150-62522	1	1				
50- 35	BRACKET (FL), step	X-194150-62532	1	1				
50- 36	BRACKET (R), step	X-194240-62541	2	2				
50- 37	ABSORBER, step	194150-62560	8	8	10			
50- 38	BRACKET (FR), step	194242-62570	1	1				
50- 39	WASHER 6	22137-060000	8	8	10			
50- 40	WASHER 10	22137-100000	2	2	10			
50- 41	COTTER PIN 1.6x18	22417-160180	8	8	10			
50- 42	BOLT M10x20	26013-100202	4	4	10			
50- 43	BOLT M10x25	26013-100252	4	4	10			

Fig. 51 SEAT

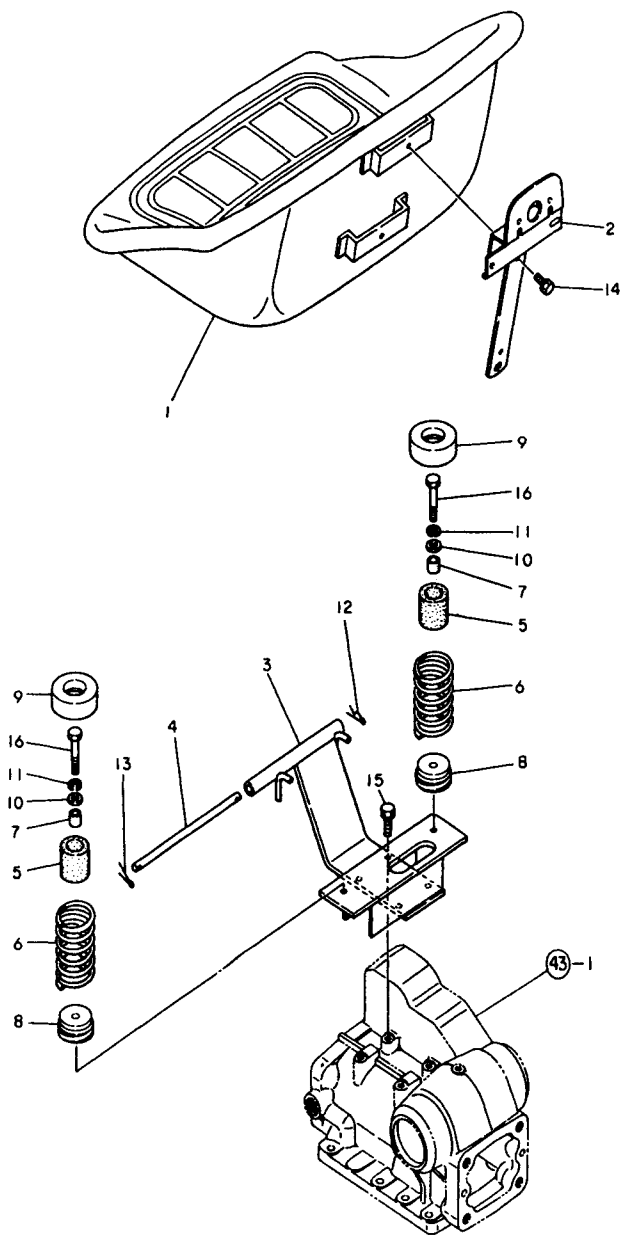

Fig. 51 SEAT

Refer. No.	Description	Part No.	Qty/Unit		Sales Unit	Interchangeability	Designation Mark	Remarks
			YM241	YM241D				
51- 1	SEAT, operator's	X-194275-63111	1	1				
51- 2	STAY, license plate	X-194242-63120	1	1				
51- 3	BRACKET, seat	X-194242-63210	1	1				
51- 4	PIN, hinge	194140-63221	1	1				
51- 5	CUSHION, rubber	194151-63240	2	2	10			
51- 6	SPRING, cushion	194281-63240	2	2	10			
51- 7	SPACER	194151-63250	2	2				
51- 8	RETAINER(B)	194322-63250	2	2				
51- 9	RETAINER(A), spring	194322-63280	2	2				
51- 10	WASHER 8	22137-080000	2	2	10			
51- 11	SPRING WASHER 8	22217-080000	2	2	10			
51- 12	SNAP PIN 8	22360-080000	1	1	10			
51- 13	COTTER PIN 2x20	22417-200200	1	1	10			
51- 14	BOLT M6x16	26013-060162	2	2	10			
51- 15	BOLT M8x25	26013-080252	4	4	10			
51- 16	BOLT M8x50	26116-080502	2	2	10			
51- 17	CHAIN	194270-71540	1	1		E		Effective from YM241 -T/#20143 YM241D-T/#40134
51- 18	BOLT M10x25	26116-100252	1	1	10	E		Effective from YM241 -T/#20143 YM241D-T/#40134
51- 19	WASHER 10	22137-100000	1	1	10	E		Effective from YM241 -T/#20143 YM241D-T/#40134
51- 20	NUT M10	194990-22150	1	1	10	E		Effective from YM241 -T/#20143 YM241D-T/#40134

Fig. 52 THREE POINT HITCH

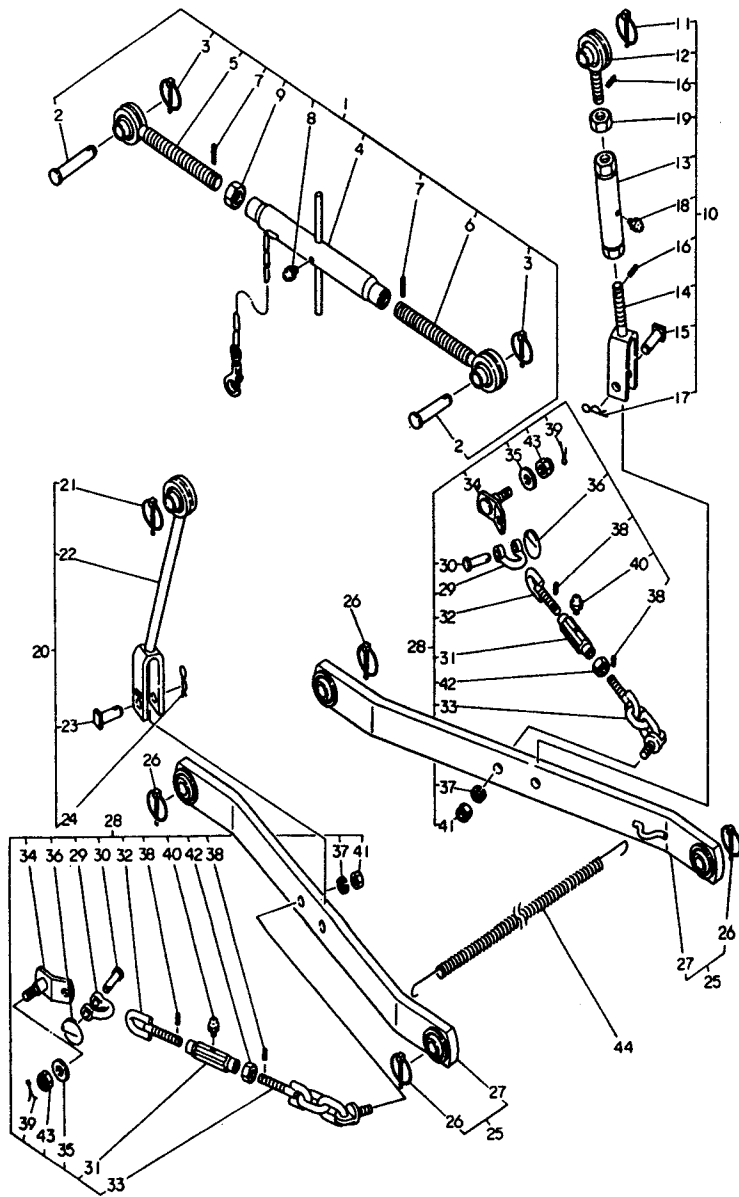

Fig. 52 THREE POINT HITCH

Refer. No.	Description	Part No.	Q'ty/Unit		Sales Unit	Interchangeability	Design/Change Mark	Remarks
			YM241	YM241D				
52- 1	LINK ASS'Y, top	X-794286-71100	1	1				
52- 2	.PIN, top link	194150-71230	2	2				
52- 3	.PIN ASS'Y, ball socket	794130-71410	2	2				
52- 4	.TURNBUCKLE, top link	X-194286-71500	1	1				
52- 5	.BOLT(R), eye	X-194322-71600	1	1				
52- 6	.BOLT(L), eye	X-194322-71700	1	1				
52- 7	.SPRING PIN 4x24	22351-040024	2	2	10			
52- 8	.GREASE NIPPLE MT6x1	24761-060000	1	1	10			
52- 9	.LOCK NUT M24	26756-240002	1	1	10			
52- 10	LINK ASS'Y(R), lift	X-794284-72100	1	1				
52- 11	.PIN ASS'Y, ball socket	794130-71410	1	1				
52- 12	.BOLT, eye	X-194170-72200	1	1				
52- 13	.TURNBUCKLE, lift link	X-194170-72230	1	1				
52- 14	.YOKE, lift link	X-194284-72450	1	1				
52- 15	.PIN, link	194145-72550	1	1				
52- 16	.SPRING PIN 4x22	22351-040022	2	2	10			
52- 17	.SNAP PIN 16	22360-160000	1	1	10			
52- 18	.GREASE NIPPLE MT6x1	24761-060000	1	1	10			
52- 19	.LOCK NUT M20	26756-200002	1	1	10			
52- 20	LINK ASS'Y(L), lift	X-794284-72210	1	1				
52- 21	.PIN ASS'Y, ball socket	794130-71410	1	1				
52- 22	.LINK(L), lift	X-194284-72400	1	1				
52- 23	.PIN, link	194145-72550	1	1				
52- 24	.SNAP PIN 16	22360-160000	1	1	10			
52- 25	.LINK ASS'Y, lower	X-794284-73110	2	2				
52- 26	.PIN ASS'Y, ball socket	794130-71410	4	4				
52- 27	.LINK, lower link	X-194284-73510	2	2				

Fig. 52 THREE POINT HITCH

Refer. No.	Description	Part No.	Qty/Unit		Sales Unit	Interchangeability	Designation	Remarks
			YM241	YM241D				
52- 28	CHAIN ASS'Y, check	X-794284-74600	2	2				
52- 29	.SHACKLE 10	194080-74621	2	2				
52- 30	.PIN 10, shackle	194080-74631	2	2	10			
52- 31	.TURNBUCKLE, check chain	194286-74680	2	2				
52- 32	.BOLT(L), eye	194286-74720	2	2				
52- 33	.CHAIN(R), check	194284-74800	2	2				
52- 34	.HINGE, check chain	194150-74910	2	2				
52- 35	.WASHER	194150-74920	2	2				
52- 36	.RING	194145-75250	2	2				
52- 37	.SPRING WASHER 14	22217-140000	2	2	10			
52- 38	.SPRING PIN 4x14	22351-040014	4	4	10			
52- 39	.COTTER PIN 3x35	22417-300350	2	2	10			
52- 40	.GREASE NIPPLE MT6x1	24761-060000	2	2	10			
52- 41	.NUT M14	26716-140002	2	2	10			
52- 42	.LOCK NUT M14	26756-140002	2	2	10			
52- 43	.CASTLE NUT M16	26817-160002	2	2	10			
52- 44	SPRING	194145-73150	1	1				

Fig. 53 REAR HITCH

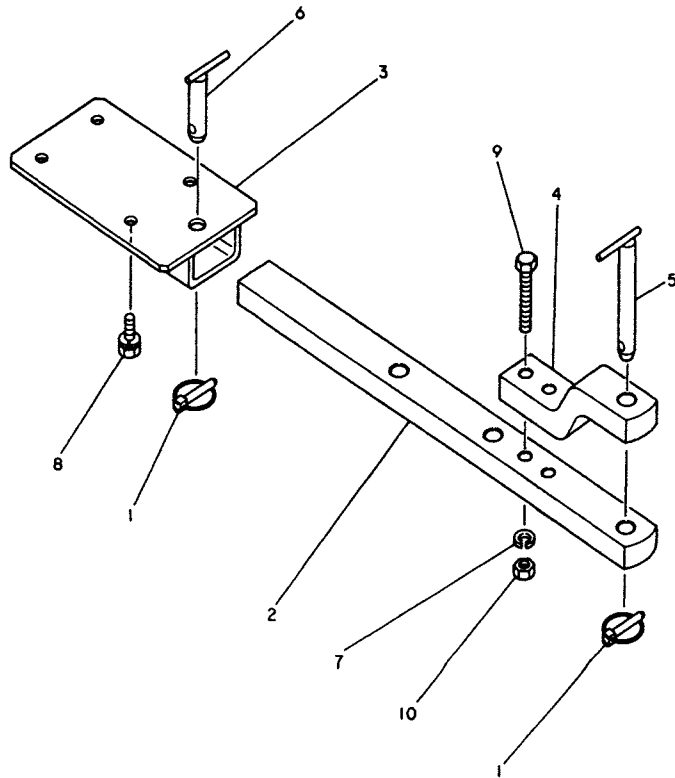

Fig. 53 REAR HITCH

Refer. No.	Description	Part No.	Qty/Unit		Sales Unit	Interchangeability	Designchange Mark	Remarks
			YM241	YM241D				
53- 1	PIN ASS'Y, ball socket	794130-71410	2	2				
53- 2	HITCH, rear	X-194242-75710	1	1				
53- 3	BRACKET, rear hitch	X-194240-75720	1	1				
53- 4	HITCH, rear (upper)	X-194242-75730	1	1				
53- 5	PIN 22x163.5, hitch	194242-75740	1	1				
53- 6	PIN 22x90, hitch	194242-75750	1	1				
53- 7	SPRING WASHER 16	22217-160000	2	2	10			
53- 8	BOLT M14x30	26013-140302	4	4	10			
53- 9	BOLT M16x90	26116-160902	2	2				
53- 10	NUT M16	26716-160002	2	2	10			



Fig. 54 TOOLS

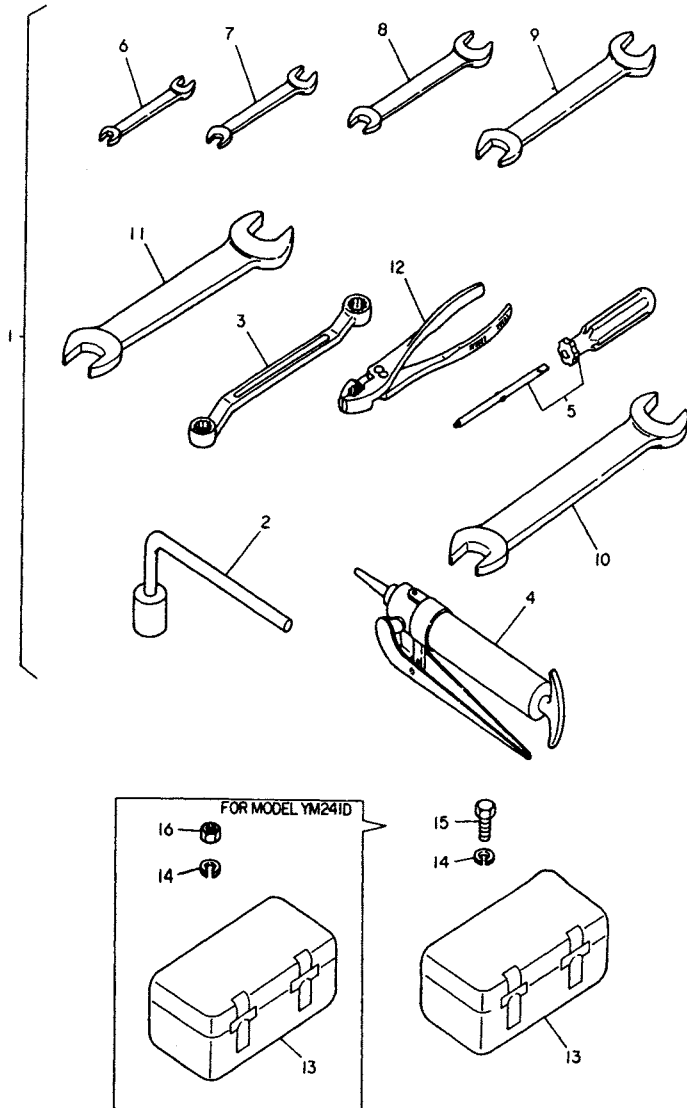

Fig. 54 TOOLS

Refer. No.	Description	Part No.	Qty/Unit		Sales Unit	Interchange-ability	Designation Part	Remarks
			YM241	YM241D				
54- 1	TOOL KIT	794150-82100	1	1				
54- 2	.BOX WRENCH 26	194740-81010	1	1				
54- 3	.BOX WRENCH 17x19	194080-82110	1	1				
54- 4	.GUN, grease	194130-82190	1	1				
54- 5	.SCREW DRIVER, reversible	104200-92350	1	1				
54- 6	.WRENCH 8x10	28110-080100	1	1				
54- 7	.WRENCH 10x13	28110-100130	1	1				
54- 8	.WRENCH 17x19	28110-170190	1	1				
54- 9	.WRENCH 22x24	28110-220240	1	1				
54- 10	.WRENCH 26x32	28110-260320	1	1				
54- 11	.WRENCH 27x30	28110-270300	1	1				
54- 12	.PLIER 150	28170-001500	1	1				
54- 13	BOX, tool	R-194112-64410	1	1				
54- 14	SPRING WASHER 10	22217-100000	2	2	10			
54- 15	BOLT M10x16	26116-100162	2		10			
54- 16	NUT M10	26716-100002		2	10			

Fig. 55 TIRES (FRONT & REAR) [FOR MODEL YM241]

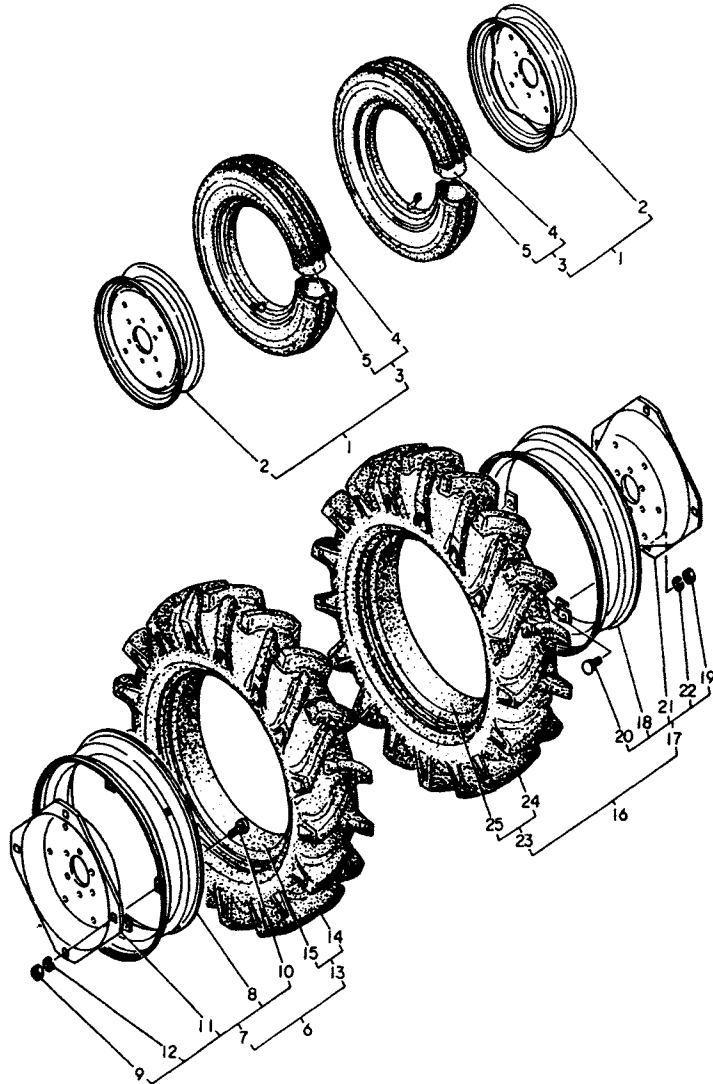

Fig. 55 TIRES (FRONT & REAR) [FOR MODEL YM241]

Refer. No.	Description	Part No.	Qty/Unit		Sales Unit	Interchangeability	Designation Mark	Remarks
			YM241	YM241D				
55- 1	TIRE ASS'Y, front wheel	P-794242-12900	2					
55- 2	.WHEEL DC3.00Dx15	P-194275-12910	2					
55- 3	.TIRE w/TUBE 4.00-15	794080-12950	2					
55- 4	..TIRE	194080-12960	2					
55- 5	..TUBE	194080-12970	2					
55- 6	TIRE ASS'Y(L), rear wheel	P-794240-35100	1					
55- 7	.WHEEL ASS'Y DCW7x24W	P-794240-34800	1					
55- 8	..WHEEL	P-194130-34821	1					
55- 9	..NUT M16	194130-34840	4		10			
55- 10	..BOLT M16x35	194130-34850	4		10			
55- 11	..DISC	P-194240-35120	1					
55- 12	..SPRING WASHER 16	22217-160000	4		10			
55- 13	.TIRE w/TUBE 9-24	794080-34930	1					
	.TIRE w/TUBE 9.5-24	194433-34900	1			A		
55- 14	..TIRE 9-24	194080-34940	1					
	..TIRE 9.5-24	194433-34910	1			A		
55- 15	..TUBE	194080-34950	1					
	..TUBE 9.5-24	194433-34920	1			A		
55- 16	TIRE ASS'Y(R), rear wheel	P-794240-35110	1					
55- 17	.WHEEL ASS'Y DCW7x24W	P-794240-34800	1					
55- 18	..WHEEL	P-194130-34821	1					
55- 19	..NUT M16	194130-34840	4		10			
55- 20	..BOLT M16x35	194130-34850	4		10			
55- 21	..DISC	P-194240-35120	1					
55- 22	..SPRING WASHER 16	22217-160000	4		10			

Fig. 55 TIRES (FRONT & REAR) [FOR MODEL YM241]

Refer. No.	Description	Part No.	Qty/Unit		Sales Unit	Interchangeability	Designchange Mark	Remarks
			YM241	YM241D				
55- 23	.TIRE w/TUBE 9-24	794080-34930	1					
	.TIRE w/TUBE 9.5-24	194433-34900	1			A		
55- 24	.TIRE 9-24	194080-34940	1					
	.TIRE 9.5-24	194433-34910	1			A		
55- 25	.TUBE	194080-34950	1					
	.TUBE 9.5-24	194433-34920	1			A		

Fig. 56 TIRES (FRONT & REAR) [FOR MODEL YM241D]

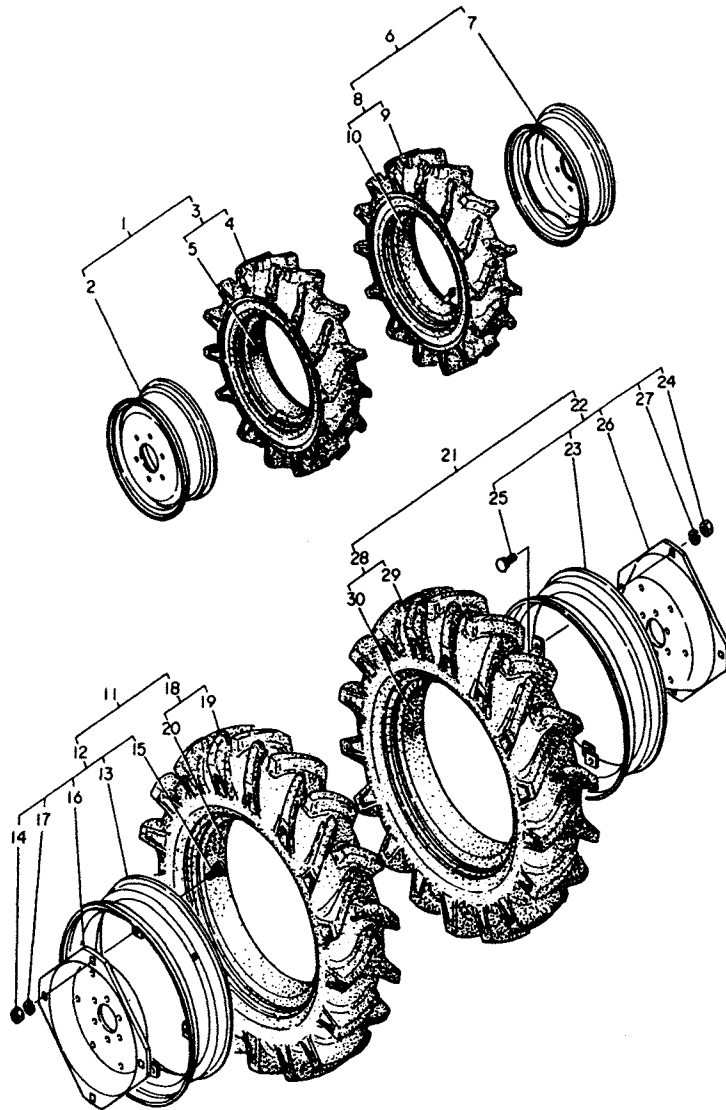

Fig. 56 TIRES (FRONT & REAR) [FOR MODEL YM241D]

Refer. No.	Description	Part No.	Q'ty/Unit		Sales Unit	Interchangeability	Designchange Mark	Remarks
			YM241	YM241D				
56- 1	TIRE ASS'Y(L), front wheel	P-794166-14700		1				
56- 2	..WHEEL DC5JAx14W	P-194311-14700		1				
56- 3	..TIRE w/TUBE 6-14	194166-14800		1				
56- 4	..TIRE 6-14	194166-14810		1				
56- 5	..TUBE	194166-14820		1				
56- 6	TIRE ASS'Y(R), front wheel	P-794166-14800		1				
56- 7	..WHEEL DC5JAx14W	P-194311-14700		1				
56- 8	..TIRE w/TUBE 6-14	194166-14800		1				
56- 9	..TIRE 6-14	194166-14810		1				
56- 10	..TUBE	194166-14820		1				
56- 11	TIRE ASS'Y(L), rear wheel	P-794240-35100		1				
56- 12	..WHEEL ASS'Y DCW7x24W	P-794240-34800		1				
56- 13	..WHEEL	P-194130-34821		1				
56- 14	..NUT M16	194130-34840		4	10			
56- 15	..BOLT M16x35	194130-34850		4	10			
56- 16	..DISC	P-194240-35120		1				
56- 17	..SPRING WASHER 16	22217-160000		4	10			
56- 18	..TIRE w/TUBE 9-24	794080-34930		1				
	..TIRE w/TUBE 9.5-24	194433-34900		1		A		
56- 19	..TIRE 9-24	194080-34940		1				
	..TIRE 9.5-24	194433-34910		1		A		
56- 20	..TUBE	194080-34950		1				
	..TUBE 9.5-24	194433-34920		1		A		

Fig. 56 TIRES (FRONT & REAR) [FOR MODEL YM241D]

Refer. No.	Description	Part No.	Q'ty/Unit		Sales Unit	Interchange-ability	Designchange Mark	Remarks
			YM241	YM241D				
56- 21	TIRE ASS'Y(R), rear wheel	P-794240-35110		1				
56- 22	..WHEEL ASS'Y DCW7x24W	P-794240-34800		1				
56- 23	..WHEEL	P-194130-34821		1				
56- 24	..NUT M16	194130-34840		4	10			
56- 25	..BOLT M16x35	194130-34850		4	10			
56- 26	..DISC	P-194240-35120		1				
56- 27	..SPRING WASHER 16	22217-160000		4	10			
56- 28	..TIRE w/TUBE 9-24	794080-34930		1				
	..TIRE 9.5-24	194433-34900		1		A		
56- 29	..TIRE 9-24	194080-34940		1				
	..TIRE 9.5-24	194433-34910		1		A		
56- 30	..TUBE	194080-34950		1				
	..TUBE 9.5-24	194433-34920		1		A		

Fig. 57 LABELS

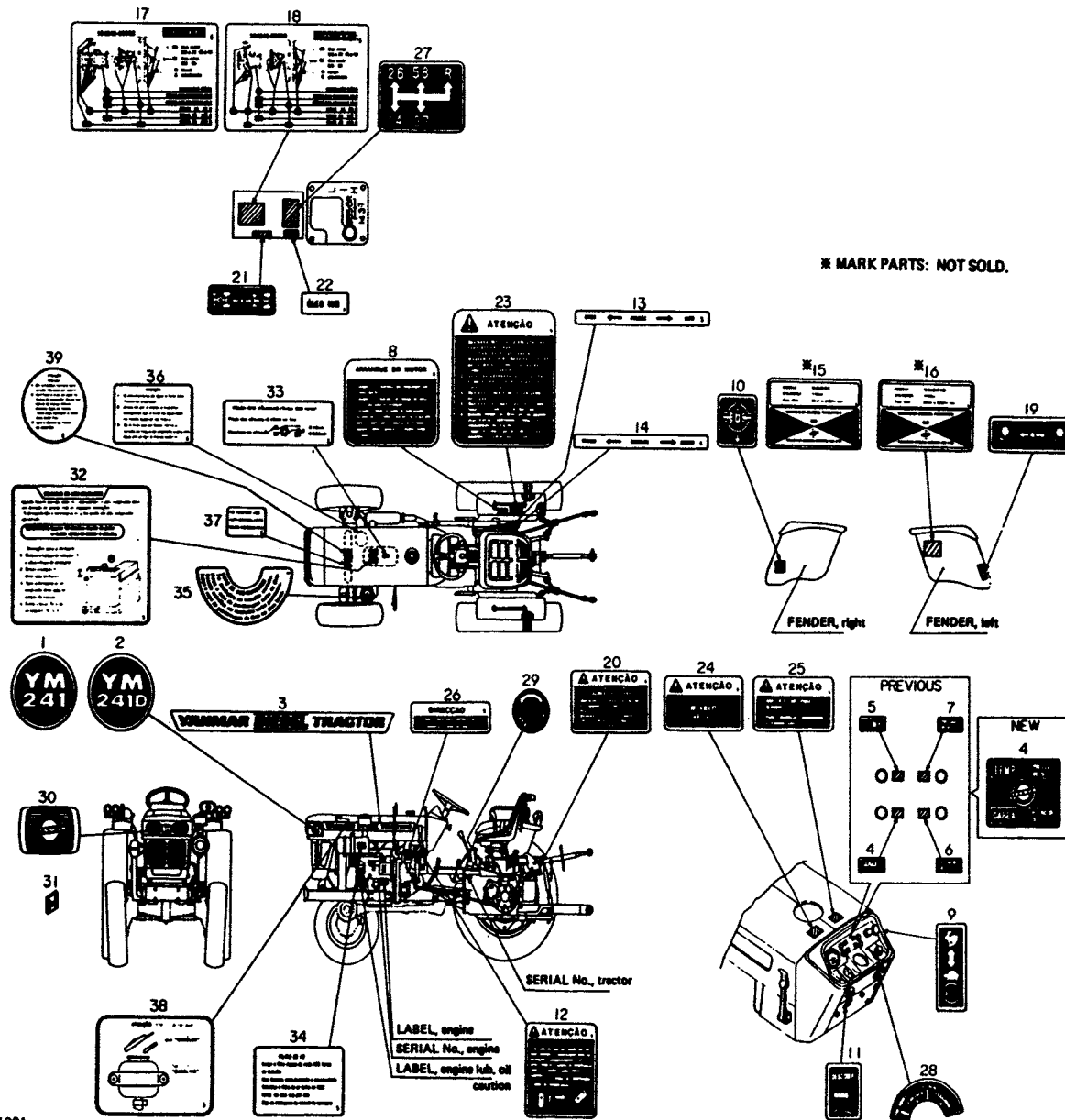

Nov., 1981

  
TO BE CONTINUED

Fig. 57 LABELS

Refer. No.	Description	Part No.	Q'ty/Unit		Sales Unit	Interchange-ability	Designation Mark	Remarks
			YM241	YM241D				
57- 1	LABEL(Model)	194242-64720	2		10			
57- 2	LABEL(Model)	194243-64720		2	10			
57- 3	LABEL(Side mark)	194240-64754	2	2	10			
57- 4	LABEL, charge lamp	194242-65310	1	1	10			Previous
	LABEL, pilot lamp	194242-65300	1	1	10	C		\$ New
57- 5	LABEL, c.w.temp. lamp	194446-65321	1	1		D		Previous
57- 6	LABEL, hyd.press. lamp	194242-65330	1	1		D		Previous
57- 7	LABEL, filter lamp	194242-65340	1	1		D		Previous
57- 8	LABEL, engine starting	194242-65350	1	1	10			
57- 9	LABEL, throttle	194240-65432	1	1	10			
57- 10	LABEL, diff.lock	194240-65441	1	1	10			
57- 11	LABEL, decompression	194242-65450	1	1	10			
57- 12	LABEL, clutch caution	194242-65460	1	1	10			
57- 13	LABEL, position indication	194242-65510	1	1	10			
57- 14	LABEL, hyd. lift	194242-65520	1	1	10			
57- 15	LABEL, tractor model	*	1		*			Not sold. (194242-65540)
57- 16	LABEL, tractor model	*		1	*			Not sold (194243-65540)
57- 17	LABEL, lubrication	194242-65550	1		10			
57- 18	LABEL, lubrication	194243-65550		1	10			
57- 19	LABEL, P.T.O.change	194273-65611	1	1	10			
57- 20	LABEL, warning	194242-65620	1	1	10			
57- 21	LABEL, 4-wheel drive	194447-65621		1	10			
Remarks:								
\$-marked parts: Labels, Ref.No.57-4(previous),5,6, & 7 which were separately provided before, are integrated into the new label, Ref.No.57-4(new). This integrated new label is to be provided hereafter.								

Nov., 1981

- 198 -

Nov., 1981

Fig. 57 LABELS

Refer. No.	Description	Part No.	Q'ty/Unit		Sales Unit	Interchange-ability	Designation Mark	Remarks
			YM241	YM241D				
57- 22	LABEL, gear oil	194242-65630	1	1	10			
57- 23	LABEL, caution	194242-65660	1	1	10			
57- 24	LABEL, fuel	194242-65670	1	1	10			
57- 25	LABEL, do not tow	194242-65680	1	1	10			
57- 26	LABEL, steering	194242-65690	1	1	10			
57- 27	LABEL, gear shift	194151-65710	1	1	10			
57- 28	LABEL, key switch	194242-65720	1	1	10			
57- 29	LABEL, slow return	194242-65750	1	1	10			
57- 30	EMBLEM, front	194200-65601	1	1	10			
57- 31	NUT 5	194200-65610	2	2	10			
57- 32	LABEL, drain caution	124742-07150	1	1	10			
57- 33	LABEL, valve adjusting	124742-07160	1	1	10			
57- 34	LABEL, aircleaner	124742-12480	1	1	10			
57- 35	LABEL, pre-cleaner	124742-12520	1	1	10			
57- 36	LABEL, sub-tank	124742-44810	1	1	10			
57- 37	LABEL, anti-freeze	124742-44920	1	1	10			
57- 38	LABEL, thermostart fuel caution	124742-77980	1	1	10			
57- 39	LABEL, radiator	124742-44800	1	1	10			

Nov., 1981

- 199 -

Nov., 1981

Fig. 58 LARGE TIRES (FRONT & REAR)

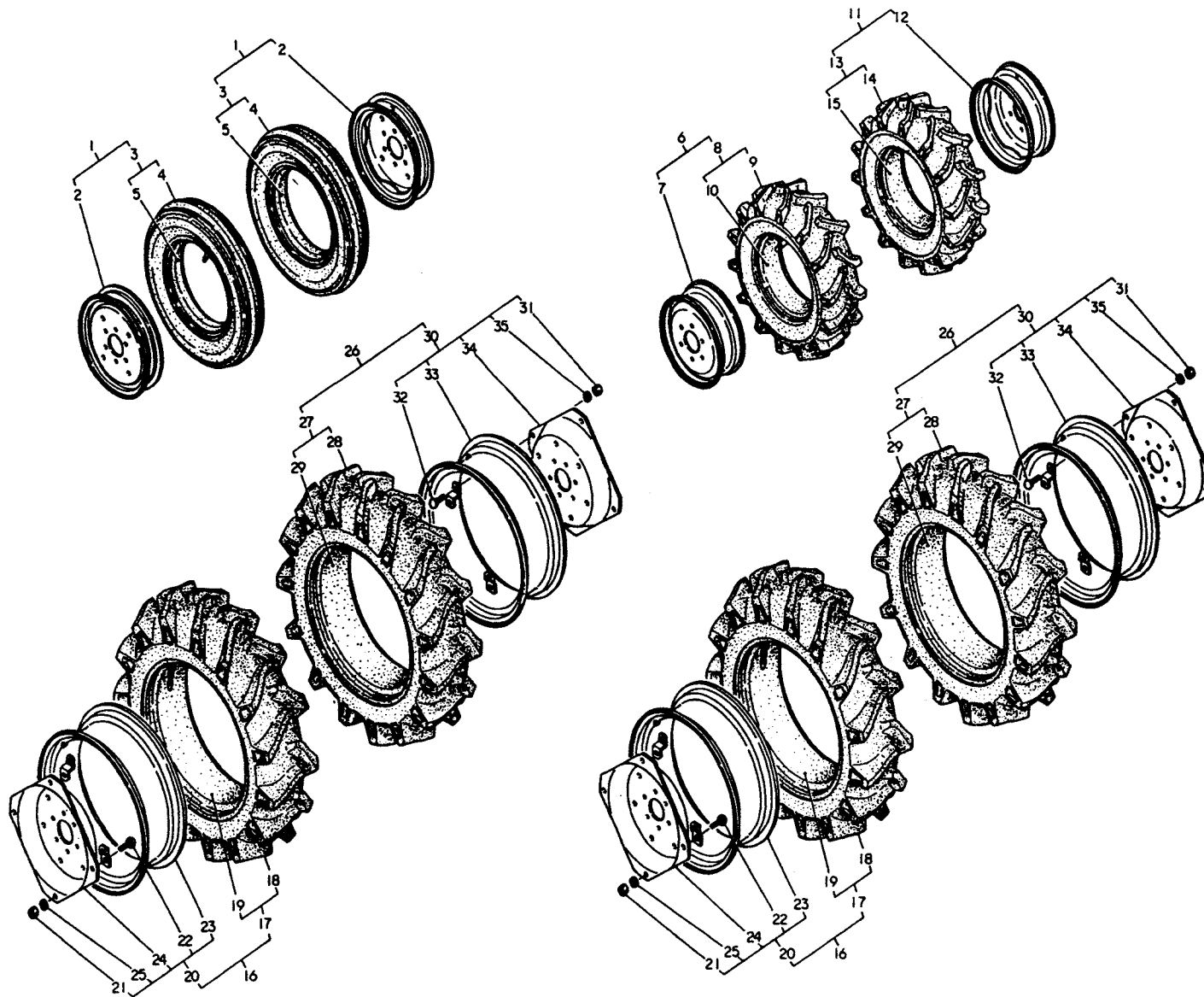



Fig. 58 LARGE TIRES (FRONT & REAR)

Refer. No.	Description	Part No.	Q'ty/Unit		Sales Unit	Interchange-ability	Designchange Mark	Remarks
			YM241	YM241D				
58- 1	TIRE ASS'Y, front wheel	P-194432-12900	2					
58- 2	.WHEEL DC3.00Dx15	P-194275-12910	2					
58- 3	.TIRE w/TUBE 5.00-15	794081-12950	2					
58- 4	..TIRE 5.00-15	194081-12960	2					
58- 5	..TUBE	194081-12970	2					
58- 6	TIRE ASS'Y(L), front wheel	P-794171-14700		1				
58- 7	.WHEEL DCSJAx14W	P-194311-14700		1				
58- 8	.TIRE w/TUBE 7-14	194171-14800		1				
58- 9	..TIRE 7-14	194171-14810		1				
58- 10	..TUBE	194171-14820		1				
58- 11	TIRE ASS'Y(R), front wheel	P-794171-14800		1				
58- 12	.WHEEL DCSJAx14W	P-194311-14700		1				
58- 13	.TIRE w/TUBE 7-14	194171-14800		1				
58- 14	..TIRE 7-14	194171-14810		1				
58- 15	..TUBE	194171-14820		1				
58- 16	TIRE ASS'Y(L), rear wheel	P-794240-35210	1	1				
58- 17	.TIRE w/TUBE 11.2-24	194432-34900	1	1				
58- 18	..TIRE 11.2-24	194432-34910	1	1				
58- 19	..TUBE	194432-34920	1	1				
58- 20	.WHEEL ASS'Y DCW9x24W	P-194240-35230	1	1				
58- 21	..NUT M16	194130-34840	4	4	10			
58- 22	..BOLT M16x35	194130-34850	4	4	10			
58- 23	..WHEEL	P-194130-34891	1	1				
58- 24	..DISC	P-194240-35120	1	1				
58- 25	..SPRING WASHER 16	22217-160000	4	4	10			

Fig. 58 LARGE TIRES (FRONT & REAR)

Refer. No.	Description	Part No.	Q'ty/Unit		Sales Unit	Interchange-ability	Designchange Mark	Remarks
			YM241	YM241D				
58- 26	TIRE ASS'Y(R), rear wheel	794240-35220	1	1				
58- 27	.TIRE w/TUBE 11.2-24	194432-34900	1	1				
58- 28	..TIRE 11.2-24	194432-34910	1	1				
58- 29	..TUBE	194432-34920	1	1				
58- 30	.WHEEL ASS'Y DCW9x24W	194240-35230	1	1				
58- 31	..NUT M16	194130-34840	4	4	10			
58- 32	..BOLT M16x35	194130-34850	4	4	10			
58- 33	..WHEEL	194130-34891	1	1				
58- 34	..DISC	194240-35120	1	1				
58- 35	..SPRING WASHER 16	22217-160000	4	4	10			

**NUMERICAL**

**PART NO. LIST**



NUMERICAL PART NO. LIST

Part No.	Description	Refer. No.	Q'ty/Unit		Remarks
			YM241	YM241D	
*	BLOCK, cylinder	1- 2	1		
*	PAN, lub. oil	1- 27			
*	LINER, cylinder	1- 43	2		
*	HOUSING, gears	2- 2	1		
*	HEAD, cylinder	3- 2	1		
*	ARM w/BUSH	3- 27	2		
*	ARM w/BUSH	3- 31	2		
*	BONNET, cyl.	3- 38	1		
*	BODY, air cleaner	4- 2	1		
*	BODY, pre-cleaner	128d 4- 10	1		
*	2nd SILENCER, exhaust	5- 3		1	
*	CAMSHAFT	34d-355L 6- 2	1		
*	CRANKSHAFT	7- 2	1		
*	HOUSING, main bearing	7- 11	1		
*	FLYWHEEL	7- 21	1		
*	PISTON	8- 2	2		
*	RING, compression(No.1)	8- 4	2		
*	RING, compression(No.2 & 3)	8- 5	4		
*	RING, oil control	8- 6	2		
*	ROD, connecting	8- 10	2		
*	BODY, f.i.pump	11- 2	1		
*	GUIDE, plunger	11- 8	2		
*	ROLLER, plunger guide(inner)	11- 10	2		
*	ROLLER, plunger guide(outer)	11- 11	2		
*	LABEL, fuel injection pump	11- 25	1		
*	LEVER, regulator	14- 25	1		
*	HANDLE, regulator	14- 26	1		
*	SHAFT, regulator handle	14- 27	1		
*	THRUST WASHER(B)	16- 4	3		
*	THRUST WASHER(C)	16- 5	1		
*	E-RING	16- 6	1		
*	STOPPER, pinion	16- 8	1		
*	CIRCLIP, pinion	16- 9	1		
*	YOKE ASS'Y	16- 10	1		
*	LEVER, shift	16- 24	1		
*	SPRING, torsion	16- 25	1		
*	COVER(A), dust	16- 30	1		
*	COVER(B), dust	16- 31	1		
*	COVER(C), dust	16- 32	1		
*	COVER(D), dust	16- 33	1		
*-marked parts: Not sold separately.					

NUMERICAL PART NO. LIST

Part No.	Description	Refer. No.	Q'ty/Unit		Remarks
			YM241	YM241D	
*	SPACER	17- 3	1		
*	HOLDER, brush	17- 9	1		
*	BRACKET(F), center pin	23- 10	1		
*	BRACKET(R), center pin	23- 14	1		
*	EXTENSION(L)	25- 3	1		
*	EXTENSION(R)	25- 10	1		
*	TIE-ROD END(RL)	25- 41	1		
*	TIE-ROD END(LR)	25- 47	1		
*	TIE-ROD END(RL)	26- 8		1	
*	TIE-ROD END(LR)	26- 14		1	
*	PINION, drive	27- 2		1	
*	GEAR, ring	27- 3		1	
*	HOUSING, differential	27- 22		1	
*	CASE, front axle	28- 2		1	
*	SPINDLE, front	29- 20		2	
*	WHEEL, steering	30- 40	1		
*	ROD, drag	30- 43	1		
*	TIE-ROD END(RL)	30- 52	1		
*	WHEEL, steering	31- 40		1	
*	ROD, drag	31- 43		1	
*	ROD, drag	31- 43		1	
*	HOUSING, clutch	32- 3	1		
*	BEARING	32- 24	1		
*	HOUSING, clutch	33- 3		1	
*	SLEEVE, bearing	33- 31		1	
*	HOUSING, transmission	34- 2	1		
*	HOUSING, transmission	35- 2		1	
*	GEAR, reduction	36- 8	1	1	
*	GEAR, reverse	36- 41	1	1	
*	COUNTERSHAFT	39- 3	1		
*	GEAR, ring	39- 4	1		
*	COUNTERSHAFT	39- 34		1	
*	GEAR, ring	39- 35		1	
*	PEDAL, differential lock	40- 20	1	1	
*	PEDAL(L), brake	41- 18			
*	COVER	42- 11	1	1	
*	GEAR, driven	42- 12	1	1	
*	GEAR, drive	42- 13	1	1	
*	BUSH	42- 14	4	4	
*	BODY	42- 15	1	1	
*-marked parts: Not sold separately.					

NUMERICAL PART NO. LIST

Part No.	Description	Refer. No.	Q'ty/Unit		Remarks
			YM241	YM241D	
*	COVER, strainer	42- 47	1	1	
*	CASE, hyd. cyl.	43- 2	1	1	
*	CASE, cyl. side	43- 8	1	1	
*	HEAD, cylinder	43- 14	1	1	
*	SHIM t=0.2	43- 65	1	1	
*	SHIM t=0.5	43- 66	1	1	
*	BODY, valve	45- 2	1	1	
*	BODY, valve	45- 2	1	1	
*	POPPET	45- 3	1	1	
*	POPPET	45- 7	1	1	
*	POPPET	45- 7	1	1	
*	POPPET	45- 13	1	1	
*	SPOOL	45- 15	1	1	
*	PLDG, spool	45- 22	1	1	
*	STUD M6x12	45- 23	1	1	
*	ARM	46- 22	1	1	
*	HINGE	47- 5	1	1	
*	BOLT	47- 11	1	1	
*	BOX, fuse	48- 33	1	1	
*	BOX, fuse	48- 33	1	1	
*	BODY, warning light	48- 44			
*	BODY, stop lamp	48- 51	2	2	
*	SOCKET	48- 65	4	4	
*	REFLECTOR	50- 20	2	2	
*	LABEL, tractor model	57- 15	1		
*	LABEL, tractor model	57- 16		1	
	*-marked parts: Not sold separately.				

NUMERICAL PART NO. LIST

Part No.	Description	Refer. No.	Q'ty/Unit		Remarks
			YM241	YM241D	
X21141360	HOLDER ASS'Y, brush	16- 16	1		
X211423001	COVER ASS'Y, rear	16- 14	1		
X21143454	PLATE, center	16- 19	1		
X21143963	COVER KIT, dust	16- 29	1		
X21144314	SPRING, brush	16- 18	4		
X211445002	PINION ASS'Y	16- 20	1		
X21144661	BUSH, gear case	16- 22	1		
X21144858	CAP	16- 34	1		
X21145312	BRUSH(+)	16- 12	2		
X21145313	BRUSH(-)	16- 17	2		
X21145352	BUSH, rear cover	16- 15	1		
X211457001	SWITCH ASS'Y, magnetic	16- 26	1		
X21145858	CAP	16- 35	1		
X21146815	THROUGH BOLT	16- 27	2		
X21147155	STOPPER SET, pinion	16- 7	1		
X21147215	SCREW, pole core	16- 13	4		
X21148110	THRUST WASHER KIT	16- 3	1		
X211482001	COIL ASS'Y, field	16- 11	1		
X211486003	CASE ASS'Y, gear	16- 21	1		
X21148652	LEVER SET, shift	16- 23	1		
X211491001	ARMATURE ASS'Y	16- 2	1		
X6201SD	BALL BEARING	17- 5	1		
X6202B	BALL BEARING	17- 22	1		
XB444001A	NUT ASS'Y, pulley	17- 4	1		
XL1151341	SPACER(E)	17- 15	1		
XL1151552	PULLEY ASS'Y	17- 24	1		
XL1152803	COVER	17- 14	1		
XL1156300	COVER ASS'Y, rear	17- 7	1		
XL1156400	COVER ASS'Y, front	17- 19	1		
XL1201403	RETAINER	17- 23	1		
XL1201404	RETAINER, bearing	17- 20	1		
XL1251801	THROUGH BOLT	17- 25	2		
XL1251802	THROUGH BOLT	17- 26	1		
XL1255310A	BOLT ASS'Y, terminal	17- 12	1		
XL1256320	CONTROL UNIT	17- 13	1		
XL135N1301	BRUSH ASS'Y	17- 8	1		
XL135N1302	N-TERMINAL	17- 10	1		
XL135N1303	COVER, bursh	17- 11	1		
XL135N2200	STATOR ASS'Y	17- 6	1		
XL1157100	ROTOR ASS'Y	17- 2	1		

NUMERICAL PART NO. LIST

Part No.	Description	Refer. No.	Q'ty/Unit		Remarks
			YM241	YM241D	
1A1020-58150	KNOB, gear shift lever	37- 21	1	1	
1A1030-12200	BALL BEARING #51106	25- 25	2		
1A1040-26320	CIRCLIP 30-H	37- 1	1	1	
1A1104-53200	WASHER	47- 18	1	1	
1E4030-27340	BALL, shifter	37- 4	1	1	
1E4060-44040	COLLAR 13.8x5	21- 27	1	1	
1E6190-54080	SLEEVE SI 25 30 13	38- 22		1	
1E6191-54330	LOCK SCREW 7x8	43- 46	1	1	
101100-55060	CHAIN	18- 1	1		
101147-12550	WING NUT	4- 15	1		
101147-59810	BOLT 8, pipe joint	13- 37	2		
101158-11230	SCREW, valve clearance	3- 28	2		
101158-11230	SCREW, valve clearance	3- 32	2		
101720-55750	PLUG M6, airvent	13- 3	2		
102103-55520	O-RING, bowl	50.7d 13- 13	1		
102103-55520	O-RING, bowl	50.7d 19- 28	1		
103338-11180	RETAINER, valve spring	3- 11	4		
103338-14200	TAPPET	6- 5	4		
103854-11490	INSULATOR, heat	3- 60	2		
103854-11490	INSULATOR, heat	19- 17	2		
103854-53100	BODY, f.i.valve	12- 4	2		
103854-53120	SPRING, valve	12- 6	2		
103854-53180	HOLDER, valve spring	12- 9	2		
104200-55321	VALVE, taper	13- 6	1		
104200-55330	SPRING, valve	13- 7	1		
104200-55341	HANDLE, fuel cock	13- 5	1		
104200-55750	LOCK SCREW, handle	13- 9	1		
104200-59170	PACKING 12	13- 30	2		
104200-59170	PACKING 12	19- 29	2		
104200-92350	SCREW DRIVER, reversible	54- 5	1	1	
104600-11100	VALVE, suction	3- 3	2		
104600-11110	VALVE, exhaust	3- 4	2		
104600-22300	PIN, piston	30d-73L 8- 7	2		
104600-22400	CIRCLIP, piston pin	32d 8- 8	4		
104700-11350	STUD, support	3- 6	2		
104900-11410	CHAMBER (REAR), pre-combus.	3- 58	2		
104900-11450	PACKING, chamber	3- 59	4		
104900-11450	PACKING, chamber	19- 16	4		
104900-53080	HOLDER, valve	12- 3	2		
110250-53150	SHIM SET	11.5d-0.5t 12- 8	2		

NUMERICAL PART NO. LIST

Part No.	Description	Refer. No.	Q'ty/Unit		Remarks
			YM241	YM241D	
110250-53150	SHIM SET	43- 64	1	1	
110250-55610	RETAINER, bowl	13- 12	1		
113200-53110	SPINDLE, inter	12- 5	2		
113200-53120	SHOE, valve spring	12- 7	2		
120220-03660	SCREW, adjusting	M5-21L 3- 44	2		
121023-77910	PLUG, thermostart	18- 7	1		
121120-12540	BAFFLE	4- 5	1		
121120-12560	BOLT, wing	4- 6	1		
121120-12570	WASHER, seal	4- 7	1		
121120-13570	PIPE, 2nd silencer	5- 4		1	
121120-13580	CLAMP	5- 5		1	
121120-66000	LEVER ASS'Y, regulator	14- 24	1		
121120-66100	FITTINGS, regulator spring	14- 21	1		
121150-49020	PIPE(B), cooling water	10- 35	1		
z- 121250-01522	FLANGE, oil feed	1- 10	1		
121250-01791	CAP w/DIPSTICK	1- 12	1		
z- 121250-01850	COVER, f.i.pump room	1- 32	1		
121250-01990	PACKING 10	1- 4	1		
121250-01990	PACKING 10	19- 2	1		
121250-02100	MAIN BEARING	7- 12	1		
121250-02100	MAIN BEARING, V-pulley side	7- 14	1		
121250-02450	RETAINER, ball bearing	6- 10	1		
121250-03783	FITTINGS	3- 52	1		
121250-14100	GEAR, camshaft	165d-21t 6- 7	1		
121250-21200	GEAR, crankshaft	85d-39t 7- 7	1		
121250-26160	CONNECTOR, hyd. oil pump	2- 32	1		
121250-26201	GEAR, pump driving	2- 26	1		
121250-26210	SPACER, ball bearing	27.2d-3t 2- 31	1		
121250-26400	SHAFT, driving gear	2- 27	1		
121250-35300	VALVE ASS'Y, control	9- 11	1		
121250-35320	SPRING, valve	9- 13	1		
121250-35330	RETAINER, spring	9- 14	1		
121250-35340	SHIM	8d 9- 15	1		
121250-42121	MOUNT, c.w.pump	10- 7	1		
121250-44901	SENDER, temperature	10- 18	1		
121250-49030	PIPE(C), cooling water	10- 36	1		
121250-49110	JOINT, c.w. pipe	1- 24	1		
121250-49160	PIPE, drain	10- 52	1		
121250-55620	SPRING	13- 14	1		
121250-59550	PIPE, fuel return	13- 35	1		

NUMERICAL PART NO. LIST

Part No.	Description	Refer. No.	Q'ty/Unit		Remarks
			YM241	YM241D	
121250-59560	PIPE, fuel return	13- 36	1		
121250-61600	SLEEVE, governor	14- 6	1		
121250-77210	COVER, generator	15- 4	1		
121252-39450	SENDER, oil pressure	9- 23	1		
121252-42200	IMPELLER	70d 10- 3	1		
121252-42240	SHAFT, impeller	10- 4	1		
121252-44510	SUB-TANK ASS'Y, radiator	10- 28	1		
Z- 121253-12110	BRACKET, air cleaner	4- 21	1		
121253-12300	CLEANER ASS'Y, air	4- 1	1		
121253-12510	ELEMENT, air cleaner	4- 3	1		
121253-12530	PAN, dust	4- 4	1		
121254-55510	BOWL, fuel strainer	13- 11	1		
121390-32200	GEAR, lub. oil pump driving	9- 2	1		
121422-59010	PIPE, fuel oil	13- 23	1		
121450-13200	GASKET	20- 2	1	1	
121450-42310	SEAL, mechanical	10- 5	1		
121450-44530	CAP, sub-tank	10- 29	1		
121454-55600	STRAINER ASS'Y, fuel	13- 1	1		
121750-44550	CLAMP, sub-tank	10- 43	1		
122117-51560	LOCK SCREW, fuel control clamp	11- 24	1		
124060-01050	PLUG PT1/8	1- 23	2		
124060-01640	PLUG M12	1- 28	1		
124060-59380	PLUG 6, air vent	13- 27	1		
124060-59391	BOLT 12, pipe joint	13- 28	1		
124060-77680	CLAMP 10	18- 2	2		
124064-12400	PRE-CLEANER ASS'Y.	115h 4- 9	1		
124064-12420	TUBE	124d 4- 11	1		
124064-12430	GASKET, tube	4- 14	2		
124064-12440	COVER (UPPER) w/GASKET	4- 13	1		
124064-12450	CLAMP, pre-cleaner	4- 17	1		
124064-12460	BOLT, clamp	4- 18	1		
124064-12470	CASE w/GASKET	4- 12	1		
124066-59100	CLAMP 8	13- 34	3		
124066-59100	CLAMP 8	22- 27	1	1	
124085-02220	OIL SEAL, crankshaft	7- 13	1		
124160-01521	BRACKET, oil feed	2- 8	(1)		
124160-01532	PACKING, cover	2- 4	1		
124160-01532	PACKING, cover	19- 9	1		
124160-01650	CLAMP, breather pipe	1- 38	1		
124160-01650	CLAMP, breather pipe	2- 13	(1)		

NUMERICAL PART NO. LIST

Part No.	Description	Refer. No.	Q'ty/Unit		Remarks
			YM241	YM241D	
124160-01751	CAP, oil feed	2- 9	(1)		
124160-01863	PACKING, f.i.pump room	1- 33	1		
124160-01863	PACKING, f.i.pump room	19- 6	1		
124160-01910	PLUG PF1/4	1- 21	1		
124160-21670	NUT M30, plated	7- 9	1		
124160-21700	DISC, oil shield	7- 24	1		
124160-34844	PACKING, flange	1- 11	1		
124160-34844	PACKING, flange	19- 3	1		
124160-39140	BOLT 10, pipe joint	9- 18	1		
124160-49480	JOINT, c.w.pipe	3- 25	1		
124160-49480	JOINT, c.w.pipe	10- 20	1		
124220-51890	RIVET 2.5x5	11- 26	2		
124240-01882	PACKING, hydraulic pump	2- 22	1		
124240-01882	PACKING, hydraulic pump	19- 11	1		
124240-51100	PLUNGER w/BARREL	11- 3	2		
124250-03621	SPRING, decompression 13d-36L	3- 41	1		
124250-03640	LOCK SCREW, shaft	3- 43	1		
124250-59260	JOINT 12, pipe	13- 24	1		
Z- 124250-91400	GEAR UNIT, tachometer	2- 34	1		
124250-91412	PACKING, gear unit	2- 35	1		
124250-91412	PACKING, gear unit	19- 12	1		
124450-01211	BOLT (A), cylinder head	1- 5	4		
124450-01220	STUD (B), cyl. head M15-80L	1- 6	1		
124450-01230	STUD (C), cyl. head M15-156L	1- 7	1		
124450-01240	WASHER 26d-4t	1- 9	2		
124450-01250	NUT, cylinder head M15-14t	1- 8	2		
124450-01511	PACKING, gear housing	2- 18	1		
124450-01511	PACKING, gear housing	19- 10	1		
124450-01610	STUD M12x25, starter	1- 47	2		
124450-01800	SEAL HTC 58 80 12, OIL	2- 23	1		
124450-01980	PACKING 14	1- 15	1		
124450-01980	PACKING 14	19- 4	1		
124450-02110	THRUST BEARING	7- 15	2		
124450-03600	SHAFT, decompression 10d-214L	3- 40	1		
124450-07300	POINTER, crankshaft V-pulley	2- 24	1		
124450-11120	SPRING, valve	3- 10	4		
124450-11161	GUIDE, suction valve	3- 8	2		
124450-11171	GUIDE, exhaust valve	3- 9	2		
124450-11250	SUPPORT w/BALL, rocker arm	3- 35	2		
124450-11290	RETAINER, rocker arm	3- 34	2		

NUMERICAL PART NO. LIST

Part No.	Description	Refer. No.	Q'ty/Unit		Remarks
			YM241	YM241D	
124450-11310	PACKING, bonnet	3- 56	1		
124450-11310	PACKING, bonnet	19- 15	1		
124450-11320	PLUG U7/8	3- 39	1		
Z- 124450-11671	COVER, side	2- 3	1		
Z- 124450-11671	COVER, side	3- 15	1		
124450-11681	PACKING, side cover	3- 16	1		
124450-11681	PACKING, side cover	19- 13	1		
124450-11800	GUIDE, suction valve	3- 8	2		
124450-11810	GUIDE, exhaust valve	3- 9	2		
124450-11900	GASKET, silencer	5- 1	2	2	
124450-11900	GASKET, silencer	19- 18	2		
124450-12571	SEAL WASHER	4- 16	1		
124450-14120	NUT, camshaft gear fitting	6- 4	1		
124450-14400	ROD, valve push 7d-196L	6- 6	4		
124450-21230	BUSH, pilot	7- 3	1		
124450-21530	NUT, end M36-27t	7- 23	1		
124450-21591	FLYWHEEL w/RING GEAR	7- 20	1		
124450-23100	BUSH, piston pin	8- 12	2		
124450-23200	BOLT, connecting rod	8- 11	2		
124450-23300	BEARING, crank pin	8- 13	2		
124450-23350	BEARING(0.25 U.S.), crank pin	8- 13	2		
124450-26410	WASHER 12, shaft 24d-4t	2- 28	1		
124450-32020	PACKING, lub. oil pump	9- 8	1		
124450-32020	PACKING, lub. oil pump	19- 20	1		
124450-35060	PIPE, lub. oil intake	9- 24	1		
124450-35070	LOCK NUT PF1/4	9- 25	1		
124450-35110	O-RING, strainer	9- 10	1		
124450-35110	O-RING, strainer	19- 21	1		
124450-35350	LOCK NUT M20	9- 16	1		
124450-39240	CLAMP	9- 22	1		
124450-44410	PACKING, pump mount.	10- 17	1		
124450-44410	PACKING, pump mount.	19- 23	1		
124450-44560	CLAMP, c.w. overflow pipe	10- 31	1		
124450-44590	CAP, radiator	10- 24	1		
124450-44610	LOCK NUT M15, radiator stay	10- 41	1		
124450-59860	CLAMP(B), fuel injection pipe	13- 20	1		
124450-61110	SUPPORT, governor weight	14- 5	1		
124450-61200	WEIGHT, governor	14- 2	2		
124450-61220	PIN, weight 6d-51L	14- 3	2		
124450-66411	SCREW, governor link connect.	14- 8	1		

NUMERICAL PART NO. LIST

Part No.	Description	Refer. No.	Q'ty/Unit		Remarks
			YM241	YM241D	
124450-66420	SPACER, governor link	14- 36	1		
124450-66430	SPACER, governor link	14- 19	1		
124450-66510	SUPPORT, governor lever	14- 38	1		
124450-66550	PIN, governor lever	14- 39	1		
124450-66822	SHAFT, injection control	14- 10	1		
124450-66850	SHOE(A), controller spring	14- 11	1		
124450-77010	STARTER(12V-1.3kW)	15- 1	1		
124450-77010	STARTER(S114-146)	16- 1	1		
124450-77250	BRACKET, generator	15- 6	1		
124460-02150	PACKING, main brg. housing	7- 16	1		
124460-02150	PACKING, main brg. housing	19- 19	1		
124460-02160	PACKING, main brg. housing	7- 17	1		
124460-03650	COVER	3- 45	2		
124460-03663	PACKING, adjust cover	3- 46	2		
124460-03663	PACKING, adjust cover	19- 14	2		
124460-11270	NUT M12	3- 7	2		
124460-11340	SEAL, valve stem	3- 13	4		
124460-11360	CAP, bonnet	3- 54	2		
124460-21651	V-PULLEY, P.T.O. crankshaft	7- 8	1		
124460-44600	STAY, radiator	10- 38	1		
124460-44850	STUD M8x48	10- 37	2		
124460-66440	LOCK WASHER, governor link	14- 20	1		
124460-66611	LEVER w/BALL, governor	14- 7	1		
124460-66850	WASHER(B), spring	14- 13	1		
124460-77701	PIPE	18- 3	1		
124460-77802	TANK, header	18- 4	1		
124460-77810	BRACKET, header tank	18- 5	1		
124460-77820	BRACE, header tank	18- 6	1		
Z- 124465-01600	FLANGE, mounting	1- 46	1		
124465-01751	PACKING, oil pan	1- 30	1		
124465-01751	PACKING, oil pan	19- 5	1		
Z- 124465-03610	LEVER, decompression	3- 42	1		
124465-39200	PIPE, lub. oil	9- 17	1		
124465-44950	PACKING 16	10- 19	1		
124465-59500	PIPE, fuel return	13- 31	1		
124465-59800	PIPE, f.i., No.1 cylinder	13- 17	1		
124465-59810	PIPE, f.i., No.2 cylinder	13- 18	1		
124465-66400	LINK, governor	14- 35	1		
124465-77330	ADJUSTER, belt	15- 7	1		
124550-01300	PACKING, cyl. liner	1- 44	4		



NUMERICAL PART NO. LIST

Part No.	Description	Refer. No.	Q'ty/Unit		Remarks
			YMS41	YMS41D	
124550-01300	PACKING, cyl. liner	19- 7	4		
124550-01900	BUSH, regulator handle shaft	1- 19	1		
124550-21600	GEAR, ring	7- 22	1		
124550-35110	STRAINER, lub. oil 80d-120L	9- 9	1		
124550-44690	COCK w/PACKING, radiator drain	10- 46	1		
124550-51301	VALVE, delivery	11- 13	2		
124550-51320	SPRING, delivery valve	11- 14	2		
124550-51341	HOLDER, delivery valve	11- 15	2		
124550-51350	PACKING, delivery valve	11- 28	2		
124550-51350	PACKING, delivery valve	19- 26	2		
124550-51370	O-RING, holder	11- 27	2		
124550-51370	O-RING, holder	19- 25	2		
124550-51951	SHIM SET, f.i.pump t=0.3,0.2	1- 39	1		
124550-55700	ELEMENT, fuel strainer 33d-90L	13- 10	1		
124550-59030	JOINT 8, pipe	13- 32	1		
124550-59090	JOINT 8, pipe	13- 33	1		
124550-59820	BOLT 8, pipe joint	9- 19	2		
124550-66370	LOCK NUT M6, adjusting bolt	14- 32	1		
124550-66420	BOLT, adjusting	14- 31	1		
124550-77030	COVER, B-terminal	15- 12	1		
124550-77710	REGULATOR	15- 3	1		
124742-07150	LABEL, drain caution	57- 32	1	1	
124742-07150	LABEL, drain caution	10- 51	1		
124742-07160	LABEL, valve adjusting	57- 33	1	1	
124742-11310	LABEL, valve adjusting	3- 61	1		
124742-12480	LABEL, air cleaner	57- 34	1	1	
124742-12480	LABEL, air cleaner	4- 8	1		
124742-12520	LABEL, pre-cleaner	57- 35	1	1	
124742-12520	LABEL, pre-cleaner	4- 19	1		
2- 124742-13500	SILENCER, exhaust	20- 8	1	1	
124742-13530	STAY, silencer	5- 15	1		
124742-44800	LABEL, radiator	57- 39	1	1	
124742-44800	LABEL, radiator	10- 47	1		
124742-44810	LABEL, sub-tank	57- 36	1	1	
124742-44810	LABEL, sub-tank	10- 32	1		
124742-44920	LABEL, anti-freeze	57- 37	1	1	
124742-44920	LABEL, anti-freeze	10- 48	1		
124742-77980	LABEL, thermostart fuel	57- 38	1	1	
124742-77980	LABEL, thermostart fuel	18- 10	1		
124750-11401	CHAMBER (FRONT), pre-combus.	3- 57	2		

NUMERICAL PART NO. LIST

Part No.	Description	Refer. No.	Q'ty/Unit		Remarks
			YMS41	YMS41D	
124750-42051	PACKING, c.w.pump	10- 6	1		
124750-42051	PACKING, cooling water pump	19- 22	1		
124756-42290	V-BELT(A38 inch)	10- 14	1		
124756-59850	CLAMP(A), fuel injection pipe	13- 19	1		
124756-77040	CAP, A-terminal	15- 13	1		
124756-77210	GENERATOR, w/coupler	15- 2	1		
124756-77210	GENERATOR, w/coupler	17- 1	1		
124763-01330	GASKET, cyl. head	1- 45	1		
124763-01330	GASKET, cyl. head	19- 8	1		
124764-02130	MAIN BEARING(0.25 U.S.)	7- 12	2		
2- 124764-12560	BRACE(B), cleaner	4- 22	1		
124764-12570	SEAT(A), brace	4- 23	2		
124764-12580	SEAT(B), brace	4- 24	1		
124764-13510	SILENCER, exhaust	5- 12	1	1	
124764-49200	RETAINER, pipe	10- 54	1		
124766-59050	CLAMP 12	10- 53	2		
124766-59050	CLAMP 12	13- 25	1		
124766-59050	CLAMP 12	13- 26	1		
124766-59050	CLAMP 12	22- 26	2	2	
124767-12040	PIPE 64Loa-54d-78L	4- 35	1		
124767-12050	PACKING, air cleaner 98L-0.5t	4- 20	1		
2- 124767-12100	BRACKET, air cleaner	4- 33	1		
124767-44500	RADIATOR	10- 23	1		
124767-44580	SCREEN, radiator	10- 33	1		
124767-44600	BRACKET, sub-tank	10- 49	1		
124768-42011	PUMP ASS'Y, cooling water	10- 1	1		
124768-42261	FLANGE, V-pulley	10- 2	1		
124768-42351	V-PULLEY	10- 11	1		
124768-44690	PLATE, shelter	10- 42	1		
124768-44740	FAN 320d	10- 12	1		
124768-44750	WASHER, fan	10- 44	2		
124768-49010	PIPE(A), cooling water	10- 21	1		
124768-66011	SPRING, regulator	14- 23	1		
124768-66800	CONTROLLER ASS'Y, injection	14- 9	1		
124768-66810	SPRING, controller	14- 12	1		
124770-53000	VALVE w/CASE	12- 2	2		
124772-66890	LOCK NUT M8	14- 18	1		
135210-61090	LEAD, sealing	14- 33	2		
171022-49520	SPRING, protect	22- 24	1	1	
172100-53200	PACKING, holder	12- 10	2		

NUMERICAL PART NO. LIST

Part No.	Description	Refer. No.	Q'ty/Unit		Remarks
			YM241	YM241D	
172100-53200	PACKING, holder	19- 27	2		
173400-11900	FLANGE, fuel injection	3- 36	2		
174100-54120	PIN, plunger guide roller	11- 12	2		
174307-51170	RETAINER, plunger spring	11- 4	2		
174307-51181	RETAINER, plunger spring	11- 5	2		
174307-51190	SPRING, plunger	11- 6	2		
174307-51250	PIN, plunger barrel	11- 16	2		
174307-51270	PACKING, plunger barrel	11- 17	2		
174307-51270	PACKING, plunger barrel	19- 24	2		
174307-51450	STOPPER, plunger guide	11- 18	2		
174307-51460	PIN, lock screw	11- 19	2		
174307-51510	PINION(A), fuel control	11- 21	1		
174307-51550	SLEEVE, fuel control pinion(B)	11- 22	1		
174307-51700	SHIM 19d	11- 29	2		
194080-09340	SEAL TC 35 55 11, oil	36- 57	1	1	
194080-11120	BUSH 30x2x40	23- 9	1		
194080-11120	BUSH 30x2x40	23- 13	1		
194080-12960	TIRE	55- 4	2		
194080-12970	TUBE	55- 5	2		
194080-15420	SHIM, adjust screw t=1.5	30- 16	-		
194080-15420	SHIM, adjust screw t=1.5	31- 16	-		
194080-15430	SHIM, adjust screw t=1.5	30- 17	-		
194080-15430	SHIM, adjust screw t=1.5	31- 17	-		
194080-15440	SHIM, adjust screw t=1.5	30- 18	-		
194080-15440	SHIM, adjust screw t=1.5	31- 18	-		
194080-15450	SHIM, adjust screw t=1.5	30- 19	-		
194080-15450	SHIM, adjust screw t=1.5	31- 19	-		
194080-15460	SHIM, adjust screw T=1.5	30- 20	-		
194080-15460	SHIM, adjust screw T=1.5	31- 20	-		
194080-15550	WASHER 12	30- 33	1		
194080-15550	WASHER 12	31- 33	1		
194080-25581	WASHER 20, tongued	36- 17	1		
194080-25590	NUT M20	36- 18	1		
194080-27172	SPRING, gear shift lever	37- 6	1	1	
194080-27190	WASHER 13x19x2	37- 7	1	1	
194080-27252	BOOT, rubber	37- 9	1	1	
194080-34940	TIRE 9-24	55- 14	1		
194080-34940	TIRE 9-24	55- 24	1		
194080-34940	TIRE 9-24	56- 19	1		
194080-34940	TIRE 9-24	56- 29	1		

NUMERICAL PART NO. LIST

Part No.	Description	Refer. No.	Q'ty/Unit		Remarks
			YM241	YM241D	
194080-34950	TUBE	55- 15	1		
194080-34950	TUBE	55- 25	1		
194080-34950	TUBE	56- 20		1	
194080-34950	TUBE	56- 30		1	
194080-37781	PIN 8x25	41- 33	4	4	
194080-51430	RUBBER, insulating	48- 16	1	1	
194080-57202	RELAY, flasher	48- 91	1	1	
194080-58810	GROMMET 8	48- 14	1	1	
194080-58810	GROMMET 8	48- 15	2	2	
194080-61810	LOCK, hood	49- 29	2	2	
194080-61820	CATCH, hood lock	49- 30	2	2	
194080-61840	PIN, hood lock	49- 31	2	2	
194080-74621	SHACKLE 10	52- 29	2	2	
194080-74631	PIN 10, shackle	52- 30	2	2	
194080-82110	BOX WRENCH 17x19	54- 3	1	1	
194081-12960	TIRE 5.00-15	58- 4	2		
194081-12970	TUBE	58- 5	2		
194081-54110	LENS, work light	48- 70	1	1	
194081-54120	GASKET, lens	48- 71	1	1	
194081-54131	RIM	48- 72	1	1	
194081-54151	SPRING	48- 73	3	3	
194081-54210	SCREW	48- 74	1	1	
194081-54221	STAY	48- 75	1	1	
194081-54230	BOLT M6x12	48- 76	2	2	
194081-54240	SPRING WASHER 6	48- 77	2	2	
194081-55820	BULB 12V 20W	48- 48	2	2	
194081-55820	BULB 12V 20W	48- 78	1	1	
194100-41670	WASHER 8.5x18x2	42- 16	1	1	
194110-37673	PIN, lock lever	41- 28	1	1	
194110-37691	SPRING, pedal lock	41- 29	1	1	
194110-56150	SHEET	48- 81	1	1	
194110-56170	FITTINGS	48- 82	1	1	
R- 194112-64410	BOX, tool	54- 13	1	1	
194130-12321	CLAMP, tie-rod	25- 34	4		
194130-12330	BOLT M10x38	25- 35	4		
194130-12720	SEAL TCx6 40 62 19, oil	25- 57	2		
194130-15470	ADJUST SCREW	30- 22	1		
194130-15470	ADJUST SCREW	31- 22		1	
194130-22170	FELT	32- 23	2		
194130-22170	FELT	33- 30		2	

NUMERICAL PART NO. LIST

Part No.	Description	Refer. No.	Q'ty/Unit		Remarks
			YM241	YM241D	
194130-22280	BUSH 20x25x25	32- 5	2		
194130-22280	BUSH 20x25x25	33- 5		2	
194130-25922	BUSH 20x1.5x15	36- 42	2	2	
194130-27390	CAP 15x5, seal	37- 16	3	3	
P- 194130-34821	WHEEL	55- 8	1		
P- 194130-34821	WHEEL	55- 18	1		
P- 194130-34821	WHEEL	56- 13		1	
P- 194130-34821	WHEEL	56- 23		1	
194130-34840	NUT M16	55- 9	4		
194130-34840	NUT M16	55- 19	4		
194130-34840	NUT M16	56- 14		4	
194130-34840	NUT M16	56- 24		4	
194130-34840	NUT M16	58- 21	4	4	
194130-34840	NUT M16	58- 31	4	4	
194130-34850	BOLT M16x35	55- 10	4		
194130-34850	BOLT M16x35	55- 20	4		
194130-34850	BOLT M16x35	56- 15		4	
194130-34850	BOLT M16x35	56- 25		4	
194130-34850	BOLT M16x35	58- 22	4	4	
194130-34850	BOLT M16x35	58- 32	4	4	
P- 194130-34891	WHEEL	58- 23	1	1	
P- 194130-34891	WHEEL	58- 33	1	1	
194130-36730	WASHER 10.5x26x3	41- 8	2	2	
194130-37560	WASHER, shaft	41- 25	1	1	
194130-37730	TURNBUCKLE M10x70	46- 2	2	2	
194130-37740	ROD(LH screw)	41- 31	2	2	
194130-43351	RING 70-P, back-up	44- 2	1	1	
194130-44480	PIN, lift arm	44- 12	2	2	
194130-46750	PLUG M18	43- 20	1	1	
194130-48650	BOLT M18, pipe joint	42- 28	1	1	
194130-82190	GUN, grease	54- 4	1	1	
194140-63221	PIN, hinge	51- 4	1	1	
194145-01260	DISC 11x40x3, friction	21- 6	1	1	
194145-04302	CAP ASS'Y	22- 3	1	1	
194145-04311	CAP(A)	22- 4	1	1	
194145-04351	LENS	22- 5	1	1	
194145-04460	SCREW M4x12	22- 6	4	4	
194145-04521	PACKING, cap	22- 7	1	1	
194145-04720	PIPE, fuel	22- 22	1	1	
194145-04810	WASHER 10	49- 62	2	2	

NUMERICAL PART NO. LIST

Part No.	Description	Refer. No.	Q'ty/Unit		Remarks
			YM241	YM241D	
194145-11350	BOLT M6x5	25- 5	1		
194145-11350	BOLT M6x5	25- 9	1		
X- 194145-11801	SPINDLE	25- 15	2		
194145-11820	COVER, spindle upper	25- 16	2		
194145-11860	SEAL TC 38 52 9, oil	25- 17	2		
194145-11870	CASTLE NUT	25- 18	2		
194145-11910	ROLLER BEARING #30205	25- 19	2		
194145-11920	ROLLER BEARING #32007	25- 20	2		
194145-11930	SHIM, spindle	25- 21	2		
194145-11970	WASHER, front spindle	t=3 25- 22	-		
194145-11980	WASHER, front spindle	t=3 25- 23	-		
194145-11990	WASHER, front spindle	t=3 25- 24	-		
X- 194145-12611	HUB, front wheel	25- 54	2		
194145-12620	STUD M14x24	29- 19		4	
194145-12630	PACKING, hub cover	25- 55	2		
X- 194145-12640	COVER, wheel hub	25- 56	2		
194145-15651	GROMMET 42	30- 36	1		
194145-15651	GROMMET 42	31- 36		1	
194145-22430	SPACER 8x18x4	32- 32	1		
194145-22430	SPACER 8x18x4	33- 39		1	
194145-22440	LEVER, pedal lock	32- 33	1		
194145-22440	LEVER, pedal lock	33- 40		1	
194145-27450	SPRING, fork lock	37- 17	3	3	
194145-27450	SPRING, fork lock	37- 30	1	1	
194145-27450	SPRING, fork lock	37- 45	1	1	
194145-27450	SPRING, fork lock	38- 3		1	
R- 194145-37540	CONNECTOR	41- 20	1	1	
194145-48370	PLUG 20	28- 11		1	
194145-52400	BOX ASS'Y, fuse	48- 32	1	1	
194145-52820	FUSE 5A	48- 34	1	1	
194145-52830	FUSE 10A	48- 35	2	2	
194145-52840	FUSE 15A	48- 36	2	2	
194145-61560	RUBBER, cushion	49- 51	2	2	
194145-61650	NUT M5	49- 20	5	5	
194145-61650	NUT M5	49- 55	5	5	
194145-64100	MIRROR, rear-view	49- 60	1	1	
194145-72550	PIN, link	52- 15	1	1	
194145-72550	PIN, link	52- 23	1	1	
194145-73150	SPRING	52- 44	1	1	
194145-75250	RING	52- 36	2	2	

NUMERICAL PART NO. LIST

Part No.	Description	Refer. No.	Q'ty/Unit		Remarks
			YMS41	YMS41D	
X- 194146-21150	COVER, side	33- 6		1	
194146-21160	PACKING, side cover	33- 7		1	
194150-01190	KNOB, throttle lever	21- 5	1	1	
194150-01270	SPACER 10x20x4	21- 7	1	1	
194150-01370	ADJUSTER, throttle	21- 10	1	1	
194150-04750	JOINT, fuel outlet	22- 23	1	1	
194150-21910	PLUG 11	32- 6	5		
194150-21910	PLUG 11	33- 8		13	
194150-22160	BUSH 22x28x22	32- 22	2		
194150-22160	BUSH 22x28x22	33- 29		2	
194150-22240	SPRING, return	32- 26	2		
194150-22240	SPRING, return	33- 33		2	
194150-22250	PIN, spring hook	32- 4	2		
194150-22250	PIN, spring hook	33- 4		2	
194150-22310	YOKE, clutch shift	32- 27	1		
194150-22310	YOKE, clutch shift	33- 34		1	
X- 194150-22410	PEDAL, clutch	32- 31	1		
X- 194150-22410	PEDAL, clutch	33- 38		1	
194150-22460	ROD(LH screw), clutch	32- 34	1		
194150-22460	ROD(LH screw), clutch	33- 41		1	
194150-22470	ROD(RH screw), clutch	32- 35	1		
194150-22470	ROD(RH screw), clutch	33- 42		1	
194150-22480	NUT M10(LH screw)	32- 36	1		
194150-22480	NUT M10(LH screw)	33- 43		1	
194150-22480	NUT M10(LH screw)	41- 16	2	2	
194150-22480	NUT M10(LH screw)	46- 1	2	2	
194150-24160	PACKING, housing	34- 20	1		
194150-24160	PACKING, housing	35- 16		1	
X- 194150-24211	COVER, housing	34- 21	1		
X- 194150-24211	COVER, housing	35- 17		1	
194150-24220	PACKING, housing cover	34- 22	1		
194150-24220	PACKING, housing cover	35- 18		1	
194150-24290	CAP w/DIPSTICK	34- 23	1		
194150-24290	CAP w/DIPSTICK	35- 19		1	
194150-24310	RETAINER, front oil seal	34- 24	1		
194150-24320	PACKING, retainer	34- 25	1		
194150-24320	PACKING, retainer	35- 21		1	
194150-24350	COVER, countershaft	34- 27	1		
194150-24360	PACKING, cover	34- 28	1		
194150-24440	PACKING, rear cover	34- 30	1		

NUMERICAL PART NO. LIST

Part No.	Description	Refer. No.	Q'ty/Unit		Remarks
			YMS41	YMS41D	
194150-24440	PACKING, rear cover	35- 24		1	
194150-24510	SHIM t=0.3	34- 34	-	-	
194150-24510	SHIM t=0.3	35- 28		-	
194150-24520	SHIM t=0.2	34- 35	-	-	
194150-24520	SHIM t=0.2	35- 29		-	
194150-24530	SHIM t=0.5	34- 36	-	-	
194150-24530	SHIM t=0.5	35- 30		-	
194150-24560	PLUG 8	34- 37	1		
194150-24560	PLUG 8	35- 31		1	
194150-25212	SHAFT, main	36- 1	1	1	
194150-25231	WASHER 20x38x4, thrust	36- 2	1	1	
194150-25231	WASHER 20x38x4, thrust	38- 2		2	
194150-25260	WASHER, thrust	36- 3	1	1	
194150-25311	GEAR, 1st & 2nd speed sliding	36- 4	1	1	
194150-25361	GEAR, 3rd & 5th speed sliding	36- 5	1	1	
194150-25530	WASHER 20x43x2.5, thrust	36- 15	1	1	
194150-25771	SPACER 20x42x7	36- 24	1	1	
194150-25810	SLEEVE, countershaft gear	36- 26	1	1	
194150-25820	GEAR, 1st speed	36- 27	1	1	
194150-25830	GEAR, 2nd speed	36- 28	1	1	
194150-25840	GEAR, 3rd speed	36- 29	1	1	
194150-25860	SPACER	36- 31	1	1	
194150-25870	CIRCLIP 40.5	36- 32	2	2	
194150-25880	SPRING	36- 33	1	1	
194150-25890	NEEDLE BEARING #HK2526	36- 34	2	2	
194150-25950	SHAFT, reverse	36- 43	1	1	
194150-25971	SHAFT, connecting	36- 45	1	1	
X- 194150-27110	LEVER, gear shift	37- 3	1	1	
194150-27210	RETAINER, gear shift lever	37- 8	1	1	
194150-27260	GUIDE, gear shift lever	37- 10	1	1	
194150-27270	PACKING, retainer	37- 11	1	1	
194150-27310	FORK, 1st & 2nd speed shift	37- 13	1	1	
194150-27320	FORK, 3rd & 5th speed shift	37- 14	1	1	
194150-27330	FORK, reverse shift	37- 15	1	1	
194150-27460	SHAFT, 1st & 2nd speed fork	37- 18	1	1	
194150-27470	SHAFT, 3rd & 5th speed fork	37- 19	1	1	
194150-27480	SHAFT, reverse fork	37- 20	1	1	
194150-27530	ARM, range shift	37- 32	1	1	
194150-27540	RETAINER, shift lever	37- 33	1	1	
194150-27610	FORK, range shift	37- 34	1	1	

NUMERICAL PART NO. LIST

Part No.	Description	Refer. No.	Q'ty/Unit		Remarks
			YM241	YM241D	
194150-27631	FORK, range shift	37- 35	1	1	
194150-27760	RETAINER	37- 50	1	1	
194150-27810	SEAL SC 20 35 8, oil	36- 58	1		
194150-27840	O-RING 80-G	34- 42	1		
194150-27840	O-RING 80-G	35- 36		1	
194150-32330	SHIM(A) t=0.2	39- 21	-	-	
194150-32340	SHIM(B) t=0.3	39- 22	-	-	
194150-32350	SHIM(C) t=1.0	39- 23	-	-	
194150-32360	SHIM(D) t=0.1	39- 24	-	-	
194150-32680	PACKING, axle housing	40- 5	2	2	
194150-33150	SPRING, return	40- 18	1	1	
194150-36511	SHOE, brake	41- 1	4	4	
194150-36550	SPRING, return	41- 2	4	4	
194150-36571	DRUM, brake	41- 3	2	2	
194150-36630	PACKING, brake cover	41- 5	2	2	
194150-36651	JOINT, air breather	39- 31	2	2	
194150-36721	ANCHOR PIN, brake	41- 7	2	2	
194150-37510	SPRING, return	41- 23	2	2	
194150-37530	SPACER, spring	41- 19	1	1	
X- 194150-37551	SHAFT, brake pedal	41- 24	1	1	
194150-37570	WASHER, shaft	1.2t 41- 26	1	1	
X- 194150-37660	LEVER, pedal lock	41- 27	1	1	
194150-42280	PIPE, breather	43- 11	1	1	
194150-45320	SPRING, relief valve	43- 61	1	1	
194150-45340	SCREW, relief valve	43- 69	1	1	
194150-45361	HOLDER, relief valve	43- 62	1	1	
194150-47621	KNOB, lever	46- 30	1	1	
X- 194150-48220	PIPE, low pressure	42- 24	1	1	
194150-48230	PIPE, low press. rubber	42- 25	1	1	
194150-48600	BOLT M28, pipe joint	42- 27	1	1	
194150-48821	CLAMP	42- 30	2	2	
194150-48830	RETAINER, pipe clamp	42- 31	1	1	
194150-48860	CLAMP, low press. pipe	42- 33	1	1	
194150-48870	SPACER, pipe clamp	42- 34	1	1	
194150-51550	COVER, battery fluid inlet	48- 18	1	1	
194150-51620	WIRE	26- 26		4	
194150-51620	WIRE	48- 9	5	5	
194150-51620	WIRE	48- 10	1	1	
194150-52160	SWITCH, horn	48- 25	1	1	
194150-52170	CAP, horn switch	48- 26	1	1	

NUMERICAL PART NO. LIST

Part No.	Description	Refer. No.	Q'ty/Unit		Remarks
			YM241	YM241D	
194150-62210	U-BOLT M10	50- 10	2	2	
X- 194150-62512	STEP(L)	50- 33	1	1	
X- 194150-62522	STEP(R)	50- 34	1	1	
X- 194150-62532	BRACKET(FL), step	50- 35	1	1	
194150-62560	ABSORBER, step	50- 37	8	8	
194150-71230	PIN, top link	52- 2	2	2	
194150-74910	HINGE, check chain	52- 34	2	2	
194150-74920	WASHER	52- 35	2	2	
194151-04260	PACKING	22- 13	2	2	
194151-04260	PACKING	50- 1	2	2	
194151-11480	GREASE NIPPLE MT6x1	25- 6	1		
194151-11480	GREASE NIPPLE MT6x1	25- 11	1		
X- 194151-15610	ARM, pitman	30- 35	1		
X- 194151-15610	ARM, pitman	31- 35		1	
194151-24770	PLUG 14	28- 5		1	
194151-24770	PLUG 14	28- 30		2	
194151-24770	PLUG 14	34- 38	1		
194151-24770	PLUG 14	35- 32		1	
194151-24770	PLUG 14	38- 1		1	
194151-36670	PLUG PT02	32- 7	1		
194151-36670	PLUG PT02	39- 25	2	2	
194151-37730	TURNBUCKLE M10x90	32- 38	1		
194151-37730	TURNBUCKLE M10x90	33- 45		1	
194151-37730	TURNBUCKLE M10x90	41- 30	2	2	
194151-37771	ROD(RH screw)	41- 32	2	2	
194151-42831	PACKING, hinge top link	43- 12	1	1	
194151-45370	PLUG, relief valve	43- 70	1	1	
194151-46261	SEAT, relief valve	43- 63	1	1	
X- 194151-46640	KNOB	43- 52	1	1	
194151-47760	SPRING WASHER 12	46- 31	4	4	
194151-48710	CLAMP, rubber pipe	42- 29	2	2	
194151-57100	HORN	48- 87	1	1	
194151-57210	SPACER	48- 92	1	1	
P- 194151-62130	SUB-FENDER(L)	50- 8	1	1	
P- 194151-62140	SUB-FENDER(R)	50- 9	1	1	
194151-63240	CUSHION, rubber	51- 5	2	2	
194151-63250	SPACER	51- 7	2	2	
194151-63250	SPACER	48- 88	2	2	
194151-65710	LABEL, gear shift	57- 27	1	1	
194155-05210	BOLT M6x16	23- 23	2		

NUMERICAL PART NO. LIST

Part No.	Description	Refer. No.	Q'ty/Unit		Remarks
			YM341	YM341D	
194155-05210	BOLT M6x16	24- 14		2	
194155-05210	BOLT M6x16	49- 1	4	4	
194155-27810	KNOB, P.T.O. shift lever	37- 51	1	1	
194155-51151	HARNNESS(E), wire	48- 5	1	1	
194155-52110	SWITCH, main	48- 20	1	1	
194155-52190	KEY, main switch	48- 21	1	1	
194155-53100	LIGHT ASS'Y, head	48- 39	2	2	
194155-53110	LIGHT UNIT	48- 40	2	2	
194155-53120	SOCKET	48- 41	2	2	
194155-55810	BULB 12V 35/25W	48- 42	2	2	
194155-61241	BOLT, hood hinge	49- 10	2	2	
194155-61251	BUSH, hood hinge	49- 11	2	2	
194159-15720	GUIDE, column	30- 37	1		
194159-15720	GUIDE, column	31- 37		1	
194160-22110	SHAFT, main driving	32- 20	1		
194162-58830	GROMMET 20	23- 3	1		
194162-58830	GROMMET 20	24- 3		1	
194165-22490	STOPPER, clutch pedal	32- 37	1		
194165-22490	STOPPER, clutch pedal	33- 44		1	
194166-14800	TIRE w/TUBE 6-14	56- 3		1	
194166-14800	TIRE w/TUBE 6-14	56- 8		1	
194166-14810	TIRE 6-14	56- 4		1	
194166-14810	TIRE 6-14	56- 9		1	
194166-14820	TUBE	56- 5		1	
194166-14820	TUBE	56- 10		1	
194167-01500	CABLE, decompression	21- 35	1	1	
194167-48160	PACKING 28	42- 22	2	2	
194167-56900	CABLE, hour-meter	48- 85	1	1	
P- 194167-61210	GRILLE, front	49- 9	1	1	
X- 194167-61320	HINGE, hood	49- 13	1	1	
P- 194167-61500	BOX, panel	49- 48	1	1	
P- 194167-61620	COVER, panel box	49- 53	1	1	
194170-42130	BUSH 55x60x40	43- 3	2	2	
X- 194170-42200	CASE ASS'Y, cyl. side	43- 7	1	1	
194170-42220	PACKING, side case	43- 10	1	1	
X- 194170-43200	HEAD ASS'Y, cylinder	43- 13	1	1	
194170-43310	PISTON	44- 1	1	1	
194170-43410	ROD, piston	44- 4	1	1	
194170-44110	CRANK, lift	44- 5	1	1	
194170-44210	SHAFT, connecting	44- 6	1	1	

NUMERICAL PART NO. LIST

Part No.	Description	Refer. No.	Q'ty/Unit		Remarks
			YM341	YM341D	
194170-44230	WASHER 45x73x3.2	44- 7	2	2	
194170-44250	SLEEVE, lifting shaft	44- 8	2	2	
194170-44260	SEAL, spline shaft	44- 9	2	2	
X- 194170-44420	ARM(L), lift	44- 10	1	1	
X- 194170-44430	ARM(R), lift	44- 11	1	1	
X- 194170-44510	ARM, feed back	44- 13	1	1	
194170-45100	VALVE ASS'Y, control	45- 1	1	1	
194170-45220	BAR, push	45- 4	1	1	
194170-45230	SPRING, LM check	45- 5	2	2	
194170-45250	HOLDER	45- 6	1	1	
194170-45320	SPRING, unload	45- 8	1	1	
194170-45330	PLUG	45- 9	1	1	
194170-45350	SPOOL	45- 10	1	1	
194170-45360	SPRING	45- 11	1	1	
194170-45370	PLUG	45- 12	1	1	
194170-45410	PLUG, spool	45- 34	1	1	
194170-45430	RING, back-up	45- 32	1	1	
194170-45440	PLUG	45- 14	1	1	
194170-45520	SPRING, spool	45- 16	1	1	
194170-45530	STOPPER, spool	45- 17	1	1	
194170-45540	PIN	45- 18	1	1	
194170-45550	BAR	45- 19	1	1	
194170-45560	WASHER 12x40x0.6	45- 20	1	1	
194170-45570	CIRCLIP	45- 21	1	1	
194170-45600	SEAT, relief valve	43- 37	1	1	
194170-45610	SPRING, relief valve	43- 38	1	1	
194170-45620	HOLDER, relief valve	43- 39	1	1	
194170-45630	PLUG, relief valve	43- 40	1	1	
194170-45700	SHIM t=0.1	43- 41	-	-	
194170-45710	SHIM t=0.2	43- 42	-	-	
194170-45720	SHIM t=0.3	43- 43	-	-	
194170-45730	SHIM t=0.5	43- 44	-	-	
194170-45740	SHIM t=1.0	43- 45	-	-	
194170-46300	VALVE, stop	43- 49	1	1	
194170-46620	BOLT, stop	43- 50	1	1	
194170-46630	HOLDER, valve	43- 51	1	1	
194170-46651	RING, back-up	43- 53	1	1	
194170-46660	SPRING, return	43- 54	1	1	
194170-46670	CAP	43- 55	1	1	
X- 194170-47310	BRACKET	46- 3	1	1	

NUMERICAL PART NO. LIST

Part No.	Description	Refer. No.	Q'ty/Unit		Remarks
			YM241	YM341D	
X- 194170-47320	PLATE	46- 4	2	2	
X- 194170-47360	LEVER, position control	46- 5	1	1	
X- 194170-47370	LEVER, draft control	46- 6	1	1	
194170-47380	SHAFT, position control	46- 8	1	1	
194170-47390	SHAFT, draft control	46- 9	1	1	
X- 194170-47400	GUIDE, position control	46- 11	1	1	
X- 194170-47410	GUIDE, draft control	46- 12	1	1	
194170-47420	BAR, position control	46- 13	1	1	
194170-47430	BAR, draft control	46- 14	1	1	
194170-47440	PLATE, friction	46- 15	1	1	
194170-47450	SHAFT, feed back	46- 17	1	1	
194170-47460	SHAFT, feed back	46- 18	1	1	
194170-47470	ARM, feed back	46- 19	1	1	
194170-47480	ARM, feed back	46- 20	1	1	
194170-47490	ARM w/BUSH	46- 21	1	1	
X- 194170-47510	ROD(C), feed back	46- 26	1	1	
194170-47520	STUD	46- 27	1	1	
194170-47530	STUD M8x90	46- 28	2	2	
194170-47540	SPACER, guide	46- 29	2	2	
194170-47710	SPRING(A)	47- 1	1	1	
194170-47720	SPRING(B)	47- 2	1	1	
194170-47720	SPRING(B)	47- 2	1	1	
X- 194170-47730	HINGE ASS'Y, top link	47- 3	1	1	
X- 194170-47740	COVER, rear	47- 6	1	1	
194170-47770	PIN(B), hinge	47- 8	1	1	
194170-47780	STOPPER, hinge	47- 9	1	1	
X- 194170-47800	BOLT w/BUSH	47- 10	1	1	
X- 194170-72200	BOLT, eye	52- 12	1	1	
X- 194170-72230	TURNBUCKLE, lift link	52- 13	1	1	
194171-14800	TIRE w/TUBE 7-14	58- 8		1	
194171-14800	TIRE w/TUBE 7-14	58- 13		1	
194171-14810	TIRE 7-14	58- 9		1	
194171-14810	TIRE 7-14	58- 14		1	
194171-14820	TUBE	58- 10		1	
194171-14820	TUBE	58- 15		1	
194180-47490	ROD(A), feed back	46- 24	2	2	
194180-47500	ROD(B), feed back	46- 25	2	2	
194190-11520	BUSH	47- 4	2	2	
194190-15560	BOLT M10x32	30 -34	2		
194190-15560	BOLT M10x32	31- 34		2	

NUMERICAL PART NO. LIST

Part No.	Description	Refer. No.	Q'ty/Unit		Remarks
			YM241	YM341D	
194190-26180	JOINT	36- 10	1	1	
194190-26180	JOINT	36- 46	2	2	
194190-26340	SPACER 20x38x4.5	36- 36	1		
194190-26860	COVER, P.T.O. shaft	34- 39	1		
194190-26860	COVER, P.T.O. shaft	35- 33		1	
194190-27280	O-RING	37- 12	1	1	
194190-31120	SHIM(A) t=0.3	27- 32		-	
194190-31130	SHIM(B) t=0.2	27- 33		-	
194190-31490	BUSH 32x36x20	27- 4		1	
194190-31490	BUSH 32x36x20	27- 21		1	
194190-31510	GEAR, side	27- 18		2	
194190-32100	HOUSING ASS'Y, differential	27- 20		1	
194190-51420	CABLE, battery earth	48- 8	1	1	
194190-61560	RIVET 5x6	49- 52	4	4	
194190-61740	ROD, battery clamp	49- 21	2	2	
194190-61750	CLAMP, battery	49- 23	1	1	
194190-61761	RUBBER, cushion	49- 25	4	4	
194191-13232	SHIM t=0.5	24- 10		-	
194191-13240	SHIM t=0.25	24- 11		-	
194191-13270	SLEEVE	26- 19		2	
194191-13331	COUPLING(B)	26- 21		1	
194191-13340	SEAL	26- 22		1	
194191-13350	SPACER 20x30x1.6	26- 23		2	
194191-13370	BOOT, rubber	26- 25		2	
194191-13530	ROLLER BEARING #HR32006xJ	27- 8		2	
194191-13540	CASTLE NUT M28x1.5	27- 9		1	
194191-13662	COLLAR 52.4x55x6	27- 39		1	
194191-13671	COLLAR 28x40x12	27- 10		1	
194191-13681	SEAL TC 40 55 8, oil	27- 40		1	
194191-28480	KNOB	38- 16		1	
194197-01160	SPRING, lock	21- 4	1	1	
194200-41170	O-RING	42- 3	1	1	
194200-41180	RING, sealing	42- 4	2	2	
194200-41190	RING, support	42- 5	2	2	
194200-41200	O-RING	42- 6	2	2	
194200-65601	EMBLEM, front	57- 30	1	1	
194200-65601	EMBLEM, front	49- 32	1	1	
194200-65610	NUT 5	57- 31	2	2	
194200-65610	NUT 5	49- 33	2	2	
194240-13520	SHIM, center pin	23- 11	1		

NUMERICAL PART NO. LIST

Part No.	Description	Refer. No.	Q'ty/Unit		Remarks
			YM241	YM241D	
X- 194240-14110	ARM(L), knuckle	25- 29	1		
X- 194240-14210	ARM(R), knuckle	25- 30	1		
X- 194240-26910	GUARD, P.T.O. shaft	34- 41	1		
X- 194240-26910	GUARD, P.T.O. shaft	35- 35		1	
X- 194240-27510	LEVER, range shift	37- 31	1	1	
P- 194240-35120	DISC	55- 11	1		
P- 194240-35120	DISC	55- 21	1		
P- 194240-35120	DISC	56- 16		1	
P- 194240-35120	DISC	56- 26		1	
P- 194240-35120	DISC	58- 24	1	1	
P- 194240-35120	DISC	58- 34	1	1	
P- 194240-35230	WHEEL ASS'Y DCW9x24W	58- 20	1	1	
P- 194240-35230	WHEEL ASS'Y DCW9x24W	58- 30	1	1	
194240-51501	BATTERY N70Z-TP	48- 17	1	1	
194240-51701	BRACKET, socket	48- 12	1	1	
194240-52120	SWITCH, light	48- 22	1	1	
194240-52210	NUT M22	48- 28	1	1	
194240-52220	STAY, start switch	48- 29	1	1	
X- 194240-62221	SUPPORT, fender	50- 12	2	2	
194240-62230	U-BOLT M10.	50- 14	1	1	
194240-62240	U-BOLT	50- 16	1	1	
X- 194240-62541	BRACKET(R), step	50- 36	2	2	
194240-64754	LABEL(Side mark)	57- 3	2	2	
194240-65432	LABEL, throttle	57- 9	1	1	
194240-65441	LABEL, diff. lock	57- 10	1	1	
X- 194240-75720	BRACKET, rear hitch	53- 3	1	1	
X- 194241-13301	SHAFT, propeller	26- 20		1	
X- 194241-14611	COVER(F), shaft	26- 29		1	
X- 194241-14641	COVER(R), shaft	26- 30		1	
X- 194241-15100	GEAR ASS'Y, steering	30- 1	1		
X- 194241-15100	GEAR ASS'Y, steering	31- 1		1	
X- 194241-15110	BODY w/BUSH	30- 2	1		
X- 194241-15110	BODY w/BUSH	31- 2		1	
X- 194241-15200	COLUMN	30- 5	1		
X- 194241-15200	COLUMN	31- 5		1	
194241-15310	BUSH, column	30- 11	1		
194241-15310	BUSH, column	31- 11		1	
194241-15350	SEAL, oil	30- 14	1		
194241-15350	SEAL, oil	31- 14		1	
194241-15500	BALL NUT	30- 23	1		

NUMERICAL PART NO. LIST

Part No.	Description	Refer. No.	Q'ty/Unit		Remarks
			YM241	YM241D	
194241-15500	BALL NUT	31- 23		1	
X- 194241-21110	HOUSING ASS'Y, clutch	33- 1		1	
194241-22100	SHAFT, main driving	33- 23		1	
194241-22250	SEAL TC 30 55 12, oil	33- 24		1	
194241-22260	SPACER 46x54.5x1	33- 25		1	
X- 194241-22330	SHAFT, clutch release	32- 28	1		
X- 194241-22330	SHAFT, clutch release	33- 35		1	
194241-24310	RETAINER, front oil seal	35- 20		1	
194241-27540	PLATE, keep	38- 4		1	
194241-28151	SHAFT, idle gear	38- 7		1	
194241-28160	GEAR, idle	38- 8		1	
194241-28180	NEEDLE BEARING #2025	38- 9		1	
194241-28211	SHAFT, front drive	38- 10		1	
194241-28310	ARM, shift	38- 12		1	
194241-28321	FORK, shift	38- 13		1	
X- 194241-28330	LEVER, clutch	38- 14		1	
194241-28341	SHAFT, fork	38- 15		1	
194241-28510	SHAFT, clutch	38- 17		1	
194241-28540	COLLAR 25x34x53.5	38- 20		1	
X- 194241-36710	CAMSHAFT, brake	41- 6	2	2	
X- 194241-42300	STRAINER ASS'Y	34- 59	1		
X- 194241-42300	STRAINER ASS'Y	35- 56		1	
194241-42310	SCREEN	34- 60	1		
194241-42310	SCREEN	35- 57		1	
X- 194241-42330	COVER, strainer	34- 61	1		
X- 194241-42330	COVER, strainer	35- 58		1	
194241-42340	STUD, strainer	34- 62	1		
194241-42340	STUD, strainer	35- 59		1	
194242-01110	LEVER, throttle	21- 2	1	1	
194242-01140	BRACKET, throttle	21- 3	1	1	
194242-01320	ROD, throttle link	21- 8	1	1	
194242-01440	ROD(A), throttle pedal	21- 22	1	1	
194242-01450	ROD(B), throttle pedal	21- 23	1	1	
194242-01460	LINK, throttle pedal	21- 24	1	1	
Z- 194242-03420	PIPE, exhaust	20- 1	1	1	
X- 194242-04230	BRACKET(R), tank	22- 11	1	1	
X- 194242-04300	STAY, water separator	22- 14	1	1	
X- 194242-11210	AXLE, front	25- 1	1		
X- 194242-16100	ROD ASS'Y, drag	30- 42	1		
X- 194242-24100	HOUSING ASS'Y, transmission	34- 1	1		



NUMERICAL PART NO. LIST

Part No.	Description	Refer. No.	Q'ty/Unit		Remarks
			YM241	YM241D	
X- 194242-37420	PEDAL(L) ASS'Y, brake	41- 17	1	1	
X- 194242-41120	PUMP ASS'Y, hydraulic	42- 1	1	1	
X- 194242-42100	CASE ASS'Y, hyd. cyl.	43- 1	1	1	
194242-42150	PACKING, hyd. cyl. case	43- 6	1	1	
194242-47710	SPRING(A)	47- 1	1	1	
X- 194242-48110	PIPE, high pressure	42- 20	1	1	
194242-51110	HARNESS(A), wire	48- 1	1	1	
194242-51120	HARNESS(B), wire	48- 2	1	1	
194242-51130	HARNESS(C), wire	48- 3	1	1	
194242-51140	HARNESS(D), wire	48- 4	1	1	
194242-51660	CLAMP(D), binding	48- 11	4	4	
194242-51820	HARNESS, socket	48- 13	1	1	
194242-53400	LIGHT ASS'Y, warning	48- 43	2	2	
194242-53600	LAMP ASS'Y, stop	48- 50	2	2	
194242-53620	BULB 12V 21/5W	48- 52	2	2	
194242-53630	LENS(red)	48- 53	2	2	
194242-53640	LENS(clear)	48- 54	2	2	
194242-55420	LENS	48- 45	4	4	
194242-55430	SCREW	48- 46	8	8	
194242-55430	SCREW	48- 55	8	8	
194242-55440	WASHER 12, fluted	48- 47	2	2	
194242-55440	WASHER 12, fluted	48- 56	2	2	
≡- 194242-62110	FENDER(L)	50- 6	1	1	
≡- 194242-62120	FENDER(R)	50- 7	1	1	
194242-62210	U-BOLT M10	50- 11	1	1	
≡- 194242-62220	STAY(L), warning light	50- 13	1	1	
≡- 194242-62230	STAY(R), warning light	50- 15	1	1	
194242-62570	BRACKET(FR), step	50- 38	1	1	
X- 194242-63120	STAY, license plate	51- 2	1	1	
X- 194242-63210	BRACKET, seat	51- 3	1	1	
194242-64120	STAY, rear-view mirror	49- 61	1	1	
194242-64720	LABEL(Model)	57- 1	2		
194242-65300	LABEL, pilot lamp	57- 4	1	1	
194242-65310	LABEL, charge lamp	57- 4	1	1	
194242-65330	LABEL, hyd. press. lamp	57- 6	1	1	
194242-65340	LABEL, filter lamp	57- 7	1	1	
194242-65350	LABEL, engine starting	57- 8	1	1	
194242-65450	LABEL, decompression	57- 11	1	1	
194242-65460	LABEL, clutch caution	57- 12	1	1	
194242-65510	LABEL, position indication	57- 13	1	1	

NUMERICAL PART NO. LIST

Part No.	Description	Refer. No.	Q'ty/Unit		Remarks
			YM241	YM241D	
194242-65520	LABEL, hyd. lift	57- 14	1	1	
194242-65550	LABEL, lubrication	57- 17	1	1	
194242-65620	LABEL, warning	57- 20	1	1	
194242-65630	LABEL, gear oil	57- 22	1	1	
194242-65660	LABEL, caution	57- 23	1	1	
194242-65670	LABEL, fuel	57- 24	1	1	
194242-65680	LABEL, do not tow	57- 25	1	1	
194242-65690	LABEL, steering	57- 26	1	1	
194242-65720	LABEL, key switch	57- 28	1	1	
194242-65750	LABEL, slow return	57- 29	1	1	
X- 194242-75710	HITCH, rear	53- 2	1	1	
X- 194242-75730	HITCH, rear(upper)	53- 4	1	1	
194242-75740	PIN 22x163.5, hitch	53- 5	1	1	
194242-75750	PIN 22x90, hitch	53- 6	1	1	
X- 194243-24100	HOUSING ASS'Y, transmission	35- 1		1	
194243-64720	LABEL(Model)	57- 2		2	
194243-65550	LABEL, lubrication	57- 18		1	
194270-71540	CHAIN	51- 17	1	1	
194273-65611	LABEL, P.T.O. change	57- 19	1	1	
194274-13560	BOLT M12x30	40- 14	12	12	
194274-13580	SPRING WASHER 12, lock	40- 15	12	12	
P- 194275-12910	WHEEL DC3.00Dx15	55- 2	2		
P- 194275-12910	WHEEL DC3.00Dx15	58- 2	2		
194275-45340	SCREW, relief valve	43- 36	1	1	
X- 194275-63111	SEAT, operator's	51- 1	1	1	
194280-34170	SPRING WASHER 16, lock	40- 43	12	12	
194281-31490	BUSH 40x2x22.5	39- 10	2	2	
194281-31570	WASHER 41x60x1.0, thrust	39- 12	2	2	
194281-31580	LINER, differential pinion	39- 13	2	2	
194281-31820	SHAFT, differential pinion	39- 14	1	1	
194281-63240	SPRING, cushion	51- 6	2	2	
194282-24471	U-NUT M14	34- 33	3		
194282-24471	U-NUT M14	35- 27		3	
194282-24471	U-NUT M14	37- 44	1	1	
194282-25510	GEAR, range shift	36- 14	1	1	
194282-27870	WASHER 14x26x2	34- 43	3		
194282-27870	WASHER 14x26x2	35- 37		3	
194282-27870	WASHER 14x26x2	37- 52	1	1	
X- 194282-32310	CARRIER(L), differential	39- 19	1	1	
X- 194282-32320	CARRIER(R), differential	39- 20	1	1	

NUMERICAL PART NO. LIST

Part No.	Description	Refer. No.	Q'ty/Unit		Remarks
			YM341	YM341D	
194282-33120	SLIDER	40- 17	1	1	
194282-33460	SEAL TC 50 68 9, oil	40- 35	2	2	
194282-33480	WASHER 13x36x6	40- 31	2	2	
194282-34130	BALL BEARING #5209	40- 39	2	2	
194282-34160	WASHER, rear axle	40- 41	2	2	
194282-34180	BOLT M16x35	40- 44	8	8	
194282-36660	PIPE 8x380, vinyl	39- 32	2	2	
X- 194282-48150	PIPE, low pressure	42- 21	1	1	
X- 194283-28110	CASE, front drive	38- 5	1	1	
194283-28220	GEAR, front drive	38- 11		1	
194283-28580	GEAR, front drive	38- 21		1	
X- 194283-48190	PIPE, low-pressure	42- 23	1	1	
X- 194284-72400	LINK(L), lift	52- 22	1	1	
X- 194284-72450	YOKE, lift link	52- 14	1	1	
X- 194284-73510	LINK, lower	52- 27	2	2	
194284-74800	CHAIN(R), check	52- 33	2	2	
194286-01350	LEVER, throttle link	21- 9	1	1	
X- 194286-01411	PEDAL, throttle	21- 20	1	1	
194286-01450	BUSH 12x18x20	21- 21	1	1	
194286-01550	BRACKET, decomp. lever	21- 36	1	1	
194286-04110	TANK, fuel	22- 1	1	1	
194286-04140	STRAINER, fuel	22- 2	1	1	
X- 194286-04220	BRACKET(L), tank	22- 10	1	1	
194286-05110	COVER(L), belt	23- 22	1	1	
194286-05110	COVER(L), belt	24- 13		1	
X- 194286-11110	BRACKET, front axle	23- 1	1		
X- 194286-11150	BRACKET, radiator	23- 2	1		
X- 194286-11150	BRACKET, radiator	24- 2		1	
X- 194286-13500	BRACKET ASS'Y(F)	23- 8	1		
X- 194286-13530	BRACKET ASS'Y(R)	23- 12	1		
194286-24340	RETAINER, bearing	34- 26	1		
194286-24340	RETAINER, bearing	35- 22		1	
X- 194286-24430	COVER, rear	34- 29	1		
X- 194286-24430	COVER, rear	35- 23		1	
194286-24451	BRACKET, P.T.O.	34- 31	1		
194286-24451	BRACKET, P.T.O.	35- 25		1	
194286-24460	SUPPORTER, P.T.O.	34- 32	3		
194286-24460	SUPPORTER, P.T.O.	35- 26		3	
194286-25530	SLEEVE 20x25x40, bearing	36- 16	1	1	
194286-25540	SPACER 20x26x3	36- 6	1	1	

NUMERICAL PART NO. LIST

Part No.	Description	Refer. No.	Q'ty/Unit		Remarks
			YM341	YM341D	
194286-25601	BEARING ASS'Y, countershaft	36- 19	1	1	
194286-25611	ROLLER BEARING	36- 20	2	2	
194286-25621	RACE, outer	36- 21	2	2	
194286-25631	SPACER	36- 22	1	1	
194286-25641	CIRCLIP 65x4.5	36- 23	1	1	
194286-25700	GEAR ASS'Y, reduction	36- 7	1	1	
194286-25730	NEEDLE BEARING 20 28 25	36- 9	2	2	
194286-25800	GEAR ASS'Y, countershaft	36- 25	1	1	
194286-25850	GEAR, 5th speed	36- 30	1	1	
194286-26210	PINION Z=12/19, P.T.O.	36- 47	1	1	
194286-26230	GEAR, P.T.O. 1st	36- 51	1	1	
194286-26260	GEAR(Z=49), P.T.O. sliding	36- 52	1	1	
194286-26310	SHAFT, P.T.O.	36- 53	1	1	
194286-27660	FORK, P.T.O. shift	37- 46	1	1	
194286-27670	SHAFT, P.T.O. shift fork	37- 47	1	1	
194286-27680	ARM, P.T.O. shift	37- 48	1	1	
X- 194286-27710	LEVER, P.T.O. change	37- 49	1	1	
194286-31400	GEAR w/COUNTERSHAFT	39- 2	1	1	
194286-31490	WASHER 30x64x3.5	39- 5	1	1	
194286-31510	GEAR, differential side	39- 11	2	2	
X- 194286-32610	HOUSING(L), rear axle	40- 3	1	1	
X- 194286-32620	HOUSING(R), rear axle	40- 4	1	1	
194286-32810	HINGE(L), lower link	40- 6	1	1	
194286-32820	HINGE(R), lower link	40- 7	1	1	
194286-33110	FORK, shift	40- 16	1	1	
X- 194286-33140	PEDAL ASS'Y, diff. lock		1	1	
X- 194286-33150	PEDAL, differential lock	40- 19	1	1	
194286-33210	FLANGE(A), differential	40- 23	1	1	
194286-33220	FLANGE(B), differential	40- 24	1	1	
194286-33410	PINION, final reduction	40- 29	2	2	
194286-33450	SPACER 25x50x14	40- 30	2	2	
194286-33550	GEAR, final reduction	40- 36	2	2	
X- 194286-34120	SHAFT, rear axle	40- 38	2	2	
194286-34150	SPACER 57x240x5.2t	40- 40	2	2	
194286-34161	STUD M16x64	40- 42	4	4	
194286-34190	SCRAPER	40- 45	4	4	
194286-34360	SLEEVE 45x60x19, oil seal	40- 46	2	2	
194286-34390	SPACER	40- 47	2	2	
194286-34830	NUT M16	40- 48	8	8	
X- 194286-36610	COVER(L), brake	41- 4	1	1	

NUMERICAL PART NO. LIST

Part No.	Description	Refer. No.	Q'ty/Unit		Remarks
			YMS01	YMS410	
X- 194286-36620	COVER(R), brake	41- 14	1	1	
194286-36740	BUSH	41- 9	2	2	
194286-48290	BRACKET, filter	42- 26	1	1	
X- 194286-48300	COVER ASS'Y, strainer	42- 46	1	1	
194286-48320	BASE, valve	42- 48	1	1	
194286-48330	SPRING, valve	42- 49	1	1	
194286-48340	BOLT	42- 50	1	1	
194286-48350	PLUG	42- 51	1	1	
194286-48360	SEAT, insulator	42- 53	1	1	
194286-48370	WASHER, lock	42- 54	1	1	
194286-56100	HOOR-METER	48- 80	1	1	
P- 194286-61100	HOOD	49- 7	1	1	
P- 194286-61160	PANEL, hood(upper)	49- 8	1	1	
194286-61430	RUBBER(AR), sealed	49- 15	1	1	
194286-61440	RUBBER(B), sealed	49- 16	1	1	
194286-61450	RUBBER(C), sealed	49- 17	2	2	
194286-61460	RUBBER(D), sealed	49- 18	1	1	
X- 194286-61530	BRACKET, panel box	49- 49	1	1	
194286-61610	PANEL, dash-board	48- 97	1	1	
X- 194286-61740	STAY, front	49- 22	1	1	
194286-61770	SUPPORT(L), rubber	49- 27	1	1	
194286-61780	SUPPORT(R), rubber	49- 28	1	1	
X- 194286-71500	TURNBUCKLE, top link	52- 4	1	1	
194286-74680	TURNBUCKLE, check chain	52- 31	2	2	
194286-74720	BOLT(L), eye	52- 32	2	2	
X- 194287-11110	BRACKET, front axle	24- 1		1	
X- 194287-16101	ROD ASS'Y, drag	31- 42		1	
X- 194287-16102	ROD ASS'Y, drag	31- 42		1	
194287-28520	CLUTCH(A)	38- 18		1	
194287-28530	CLUTCH(B)	38- 19		1	
194287-28540	LOCK NUT M16	36- 37		1	
194287-28550	LOCK NUT M16	36- 38		1	
194287-28560	WASHER 16.5x30x6.5	36- 39		1	
194287-31400	GEAR w/COUNTERSHAFT	39- 33		1	
194287-61410	RUBBER(AL), sealed	49- 14	1	1	
X- 194287-61750	PLATE(L), side	49- 24	1	1	
X- 194287-61760	PLATE(R), side	49- 26	1	1	
194310-04250	CLAMP, fuel tank	22- 12	2	2	
X- 194310-15150	COVER w/BUSH, side	30- 3		1	
X- 194310-15150	COVER w/BUSH, side	31- 3		1	

NUMERICAL PART NO. LIST

Part No.	Description	Refer. No.	Q'ty/Unit		Remarks
			YMS01	YMS410	
194310-15170	PLUG PT01	30- 4	1		
194310-15170	PLUG PT01	31- 4		1	
194310-15181	BOLT M10x80	30- 32	2		
194310-15181	BOLT M10x80	31- 32		2	
194310-15320	PACKING, side cover	30- 12	1		
194310-15320	PACKING, side cover	31- 12		1	
194310-15411	SHAFT, sector	30- 15	1		
194310-15411	SHAFT, sector	31- 15		1	
194310-47790	PLATE, friction	46- 32	1	1	
X- 194311-11510	PIN, center	24- 8		1	
194311-11520	SPACER 30x55x18	24- 9		1	
X- 194311-12110	ARM(L), knuckle	26- 1		1	
X- 194311-12210	ARM(R), knuckle	26- 2		1	
X- 194311-12310	TIE-ROD	26- 4		1	
194311-13101	GEAR ASS'Y, ring	27- 1		1	
194311-13130	SHIM t=0.4	27- 5		-	
194311-13140	SHIM t=0.5	27- 6		-	
194311-13150	SHIM t=0.6	27- 7		-	
194311-13360	SPRING	26- 24		1	
X- 194311-13401	CASE ASS'Y	28- 1		1	
194311-13420	BUSH 30x34x25	28- 3		2	
194311-13430	SEAL KC 30 42 7, oil	28- 4		2	
194311-13450	CAP, front axle case	27- 36		1	
194311-13460	SHIM(A) t=0.3	27- 37		-	
194311-13470	SHIM(B) t=0.2	27- 38		-	
194311-13510	SHAFT, front 1st	27- 27		2	
194311-13520	PINION	27- 28		2	
194311-13530	SHIM(A) t=0.2	27- 29		-	
194311-13540	SHIM(B) t=0.3	27- 30		-	
194311-13550	SPACER	27- 31		2	
X- 194311-13611	AXLE, front	28- 8		2	
194311-13620	PACKING, front axle	28- 9		2	
194311-13631	DIPSTICK	28- 10		1	
X- 194311-13710	CASE, front gear(upper)	28- 20		2	
194311-13720	SEAL TCx6 25 40 7, oil	28- 21		2	
194311-13730	BOLT, stopper	28- 22		2	
X- 194311-13751	CASE, front gear(lower)	28- 23		2	
194311-13760	SEAL TCS 115 145 13.5, oil	28- 24		2	
X- 194311-13771	CAP, front gear case	28- 25		2	
194311-13790	SEAL TCPY 50 68 14.3, oil	28- 27		2	

NUMERICAL PART NO. LIST

Part No.	Description	Refer. No.	Q'ty/Unit		Remarks
			YM241	YM241D	
X- 194311-13810	BRACKET(L), king pin	28- 28		1	
X- 194311-13820	BRACKET(R), king pin	28- 29		1	
194311-13850	SHAFT, front 2nd	29- 1		2	
194311-13860	SHIM(A) t=1.0	29- 2		-	
194311-13870	SHIM(B) t=1.2	29- 3		-	
194311-13880	NEEDLE BEARING #K283518	29- 4		4	
194311-13890	COLLAR 28x33.5x22.5	29- 5		2	
194311-13910	WASHER 28x33.5x2, thrust	29- 6		2	
194311-13920	CIRCLIP WR28	29- 7		2	
194311-13930	SPACER 25x35x5	29- 8		2	
194311-13940	GEAR	29- 9		2	
194311-13950	PINION	29- 10		2	
194311-13960	CIRCLIP 50-S	29- 11		2	
X- 194311-14101	SPINDLE ASS'Y, front	29- 18		2	
194311-14121	GEAR, front final	29- 21		2	
194311-14130	WASHER 35	29- 22		2	
194311-14161	COLLAR 48.6x38.5	29- 23		2	
194311-14172	COLLAR 40x50x20	29- 24		2	
194311-14180	SHIM(A) t=0.2	29- 25		-	
194311-14190	SHIM(B) t=0.3	29- 26		-	
194311-14650	BOOT, shaft	26- 31		1	
P- 194311-14700	WHEEL DC5JAx14W	56- 2		1	
P- 194311-14700	WHEEL DC5JAx14W	56- 7		1	
P- 194311-14700	WHEEL DC5JAx14W	58- 7		1	
P- 194311-14700	WHEEL DC5JAx14W	58- 12		1	
194311-28120	SEAL TC 30 47 8, oil	38- 6		1	
194320-47760	PIN 22	47- 7	1	1	
194320-47860	LOCK BOLT M10	47- 13	1	1	
194321-13210	HOUSING, differential	39- 8	1	1	
194321-13230	PINION, differential	39- 9	2	2	
194321-13920	SEAL TC 60 75 9, oil	40- 1	2	2	
194321-13930	SEAL VC 60 75 6, oil	40- 2	2	2	
X- 194322-47910	BAR, lock	47- 14	2	2	
194322-47920	BOLT, fulcrum	47- 15	2	2	
X- 194322-47930	SPRING(L), lock bar	47- 16	1	1	
X- 194322-47940	SPRING(R), lock bar	47- 17	1	1	
194322-61260	PAD(C)	49- 12	1	1	
194322-63250	RETAINER(B)	51- 8	2	2	
194322-63280	RETAINER(A), spring	51- 9	2	2	
X- 194322-71600	BOLT(R), eye	52- 5	1	1	

NUMERICAL PART NO. LIST

Part No.	Description	Refer. No.	Q'ty/Unit		Remarks
			YM241	YM241D	
X- 194322-71700	BOLT(L), eye	52- 6	1	1	
194362-13780	PACKING, gear case	28- 26		2	
194370-26870	PACKING, P.T.O. cover	34- 40	1		
194370-26870	PACKING, P.T.O. cover	35- 34		1	
X- 194370-44520	RETAINER, shaft	44- 14	1	1	
194370-48350	VALVE	42- 52	1	1	
194370-48390	STRAINER	42- 58	1	1	
194420-15700	WHEEL ASS'Y, steering	30- 39	1		
194420-15700	WHEEL ASS'Y, steering	31- 39		1	
194420-31820	SHAFT, pinion	27- 19		1	
X- 194420-34310	BRACKET, oil seal	40- 8	2	2	
194420-34340	PACKING, housing	40- 9	2	2	
194420-47370	KNOB, lever	46- 7	1	1	
194420-51410	CABLE, battery	48- 7	1	1	
194420-61640	SCREW M5x16	49- 19	5	5	
194420-61640	SCREW M5x16	49- 54	5	5	
X- 194432-11300	EXTENSION ASS'Y(L)	25- 2	1		
X- 194432-11400	EXTENSION ASS'Y(R)	25- 7	1		
X- 194432-12310	TIE-ROD	25- 33	1		
X- 194432-12340	EXTENSION(L), tie-rod	25- 36	1		
X- 194432-12350	EXTENSION(R), tie-rod	25- 37	1		
P- 194432-12900	TIRE ASS'Y, front wheel	58- 1	2		
194432-34900	TIRE w/TUBE 11.2-24	58- 17	1	1	
194432-34900	TIRE w/TUBE 11.2-24	58- 27	1	1	
194432-34910	TIRE 11.2-24	58- 18	1	1	
194432-34910	TIRE 11.2-24	58- 28	1	1	
194432-34920	TUBE	58- 19	1	1	
194432-34920	TUBE	58- 29	1	1	
194432-41150	SEAL, oil	42- 2	1	1	
194432-41210	WOODRUFF KEY	42- 7	1	1	
194433-34900	TIRE w/TUBE 9.5-24	55- 13	1		
194433-34900	TIRE w/YUBE 9.5-24	55- 23	1		
194433-34900	TIRE w/TUBE 9.5-24	56- 18		1	
194433-34900	TIRE w/TUBE 9.5-24	56- 28		1	
194433-34910	TIRE 9.5-24	55- 14	1		
194433-34910	TIRE 9.5-24	55- 24	1		
194433-34910	TIRE 9.5-24	56- 19		1	
194433-34910	TIRE 9.5-24	56- 29		1	
194433-34920	TUBE 9.5-24	55- 15	1		
194433-34920	TUBE 9.5-24	55- 25	1		

NUMERICAL PART NO. LIST

Part No.	Description	Refer. No.	Qty/Unit		Remarks
			YM241	YM241D	
194433-34920	TUBE 9.5-24	56- 20		1	
194433-34920	TUBE 9.5-24	56- 30		1	
194440-15340	PLUG, rubber	30- 13	1		
194440-15340	PLUG, rubber	31- 13		1	
194440-15870	CAP, steering wheel	30- 41	1		
194440-15870	CAP, steering wheel	31- 41		1	
194440-51180	PLATE, earth	48- 6	1	1	
194440-51620	CLAMP(B)	22- 25	1	1	
194440-51620	CLAMP(B)	41- 15	1	1	
194440-52130	SWITCH, warning light	48- 23	1	1	
194440-52190	SWITCH, safety start	48- 27	1	1	
194440-52400	BOX ASS'Y, fuse	48- 32	1	1	
194440-55100	INDICATOR ASS'Y	48- 64	4	4	
194440-55820	BULB 12V 3.4W	48- 66	4	4	
194440-61550	PACKING, panel box	49- 50	2	2	
194446-65321	LABEL, c.w. temp. lamp	57- 5	1	1	
194447-65621	LABEL, 4-wheel drive	57- 21		1	
194450-47390	STOPPER	46- 10	1	1	
194450-52150	SWITCH, stop lamp	48- 24	1	1	
194450-53800	LIGHT ASS'Y, license plate	48- 58	1	1	
194450-53810	BULB 12V 10W	48- 59	1	1	
194450-53820	LENS	48- 60	1	1	
194450-53830	COVER	48- 61	1	1	
194450-53870	SCREW M5x70	48- 62	2	2	
194450-53880	SHADE	48- 63	1	1	
194464-11340	BUSH 30x34x32	25- 4	2		
194464-11340	BUSH 30x34x32	25- 8	2		
194464-15450	SEAL WASHER	30- 21	1		
194464-15450	SEAL WASHER	31- 21		1	
X- 194464-16130	TURNBUCKLE	30- 48	1		
194464-45920	PLUG 3/4-16UNF	34- 19	1		
194464-45920	PLUG 3/4-16UNF	35- 15		1	
194464-45920	PLUG 3/4-16UNF	43- 16	1	1	
194464-45920	PLUG 3/4-16UNF	43- 17	3	3	
194464-45930	O-RING 8-1	34- 18	1		
194464-45930	O-RING 8-1	35- 14		1	
194464-45930	O-RING 8-1	43- 18	1	1	
194464-45930	O-RING 8-1	43- 19	3	3	
194464-47440	BOLT, stopper	46- 16	1	1	
194464-47890	BOLT M14x28	25- 59	12		

NUMERICAL PART NO. LIST

Part No.	Description	Refer. No.	Qty/Unit		Remarks
			YM241	YM241D	
194464-48850	PROTECTOR, pipe clamp	42- 32	1	1	
194465-14220	SPRING WASHER 14	25- 58	12		
194730-57220	BOOT, tie-rod end	25- 42	1		
194730-57220	BOOT, tie-rod end	25- 48	1		
194730-57220	BOOT, tie-rod end	26- 9		1	
194730-57220	BOOT, tie-rod end	26- 15		1	
194730-57220	BOOT, tie-rod end	30- 44	1		
194730-57220	BOOT, tie-rod end	30- 53	1		
194730-57220	BOOT, tie-rod end	31- 44		2	
194730-57241	CASTLE NUT M12	25- 43	1		
194730-57241	CASTLE NUT M12	25- 49	1		
194730-57241	CASTLE NUT M12	26- 10		1	
194730-57241	CASTLE NUT M12	26- 16		1	
194730-57241	CASTLE NUT M12	30- 45	1		
194730-57241	CASTLE NUT M12	30- 54	1		
194730-57241	CASTLE NUT M12	31- 45		2	
194730-57411	GREASE NIPPLE 1/4	25- 44	1		
194730-57411	GREASE NIPPLE 1/4	25- 50	1		
194730-57411	GREASE NIPPLE 1/4	26- 11		1	
194730-57411	GREASE NIPPLE 1/4	26- 17		1	
194740-00160	WASHER 10, spring	21- 1	2	2	
194740-06080	BUSH 25x30x18, pedal	32- 2	2		
194740-06080	BUSH 25x30x18, pedal	33- 2		4	
194740-10850	PINION, differential	27- 15		2	
194740-10870	WASHER 14x30x0.8, thrust	27- 16		2	
194740-10880	WASHER 35x44x0.8, thrust	27- 17		2	
194740-20251	WASHER 13x36x4.5	21- 26	1	1	
194740-55620	SEAL, oil	30- 25	1		
194740-55620	SEAL, oil	31- 25		1	
194740-70270	BAR, assist	50- 17	2	2	
194740-76200	REFLECTOR ASS'Y	50- 18	2	2	
194740-81010	BOX WRENCH 26	54- 2	1	1	
194750-04400	SPRING, throttle	21- 25	1	1	
194750-15250	SHIM t=0.05	30- 6	-	-	
194750-15250	SHIM t=0.05	31- 6	-	-	
194750-15260	SHIM t=0.07	30- 7	-	-	
194750-15260	SHIM t=0.07	31- 7	-	-	
194750-15270	SHIM t=0.08	30- 8	-	-	
194750-15270	SHIM t=0.08	31- 8	-	-	
194750-15280	SHIM t=0.1	30- 9	-	-	

NUMERICAL PART NO. LIST

Part No.	Description	Refer. No.	Q'ty/Unit		Remarks
			YM241	YM241D	
194750-15280	SHIM t=0.1	31- 9	-	-	
194750-15290	SHIM t=0.2	30- 10	-	-	
194750-15290	SHIM t=0.2	31- 10	-	-	
194750-15520	BEARING	30- 24	2	-	
194750-15520	BEARING	31- 24	-	2	
194990-20180	NUT M8	42- 18	1	1	
194990-22030	NUT M5	48- 38	2	2	
194990-22030	NUT M5	49- 2	4	4	
194990-22030	NUT M5	50- 19	2	2	
194990-22040	NUT M6	48- 86	2	2	
194990-22040	NUT M6	48- 90	2	2	
194990-22050	NUT M8	4- 32	2	-	
194990-22050	NUT M8	20- 3	4	4	
194990-22050	NUT M8	22- 15	6	6	
194990-22050	NUT M8	48- 19	1	1	
194990-22050	NUT M8	48- 68	1	1	
194990-22120	NUT M5	48- 96	6	6	
194990-22120	NUT M5	49- 3	4	4	
194990-22120	NUT M5	49- 4	6	6	
194990-22130	NUT M6	42- 19	2	2	
194990-22130	NUT M6	49- 5	1	1	
194990-22130	NUT M6	50- 2	8	8	
194990-22130	NUT M6	50- 3	4	4	
194990-22140	NUT M8	20- 4	2	2	
194990-22140	NUT M8	49- 6	2	2	
194990-22140	NUT M8	50- 4	2	2	
194990-22140	NUT M8	50- 5	4	4	
194990-22150	NUT M10	51- 20	1	1	
194990-22830	NUT M17 (LH screw)	25- 38	1	-	
194990-22830	NUT M17 (LH screw)	26- 5	-	1	
194990-22830	NUT M17 (LH screw)	30- 49	1	-	
194990-22840	NUT M17 (RH screw)	25- 39	1	-	
194990-22840	NUT M17 (RH screw)	26- 6	-	1	
194990-22840	NUT M17 (RH screw)	30- 50	1	-	
194990-42710	BEARING, clutch	32- 25	1	-	
194990-42710	BEARING, clutch	33- 32	-	1	
194990-57740	O-RING 30x2.4	25- 26	2	-	
194990-85561	KNOB, range shift lever	37- 36	1	1	
195084-13540	BALL BEARING #NF306	39- 1	1	1	
22117-050000	WASHER 5	15- 14	1	-	

NUMERICAL PART NO. LIST

Part No.	Description	Refer. No.	Q'ty/Unit		Remarks
			YM241	YM241D	
22117-060000	WASHER 6	34- 63	1	-	
22117-060000	WASHER 6	35- 60	-	1	
22117-080000	WASHER 8	5- 18	4	-	
22117-080000	WASHER 8	10- 10	3	-	
22117-080000	WASHER 8	10- 27	4	-	
22117-080000	WASHER 8	13- 16	1	-	
22117-080000	WASHER 8	46- 33	6	6	
22117-100000	WASHER 10	5- 9	-	1	
22117-100000	WASHER 10	46- 34	12	12	
22117-200000	WASHER 20	40- 25	1	1	
22137-060000	WASHER 6	1- 35	6	-	
22137-060000	WASHER 6	10- 40	4	-	
22137-060000	WASHER 6	50- 39	8	8	
22137-080000	WASHER 8	51- 10	2	2	
22137-080000	WASHER 8	2- 16	13	-	
22137-080000	WASHER 8	3- 19	1	-	
22137-080000	WASHER 8	15- 11	1	-	
22137-080000	WASHER 8	20- 5	2	2	
22137-080000	WASHER 8	21- 11	3	3	
22137-080000	WASHER 8	21- 28	4	4	
22137-080000	WASHER 8	34- 44	2	-	
22137-080000	WASHER 8	35- 38	-	2	
22137-080000	WASHER 8	42- 35	2	2	
22137-080000	WASHER 8	42- 55	2	2	
22137-080000	WASHER 8	46- 35	1	1	
22137-080000	WASHER 8	49- 56	2	2	
22137-080000	WASHER 8	50- 21	4	4	
22137-100000	WASHER 10	21- 12	1	1	
22137-100000	WASHER 10	22- 28	1	1	
22137-100000	WASHER 10	26- 32	-	2	
22137-100000	WASHER 10	32- 39	2	-	
22137-100000	WASHER 10	33- 46	-	2	
22137-100000	WASHER 10	49- 34	2	2	
22137-100000	WASHER 10	49- 62	2	2	
22137-100000	WASHER 10	50- 40	2	2	
22137-100000	WASHER 10	51- 19	1	1	
22137-120000	WASHER 12	46- 36	2	2	
22137-160000	WASHER 16	29- 12	-	2	
22137-270000	WASHER 27	23- 15	1	-	
22157-060000	WASHER 6	49- 35	2	2	

NUMERICAL PART NO. LIST

Part No.	Description	Refer. No.	Q'ty/Unit		Remarks
			YM241	YM241D	
22157-080000	WASHER 8	21- 29	1	1	
22157-100000	WASHER 10	21- 13	1	1	
22157-100000	WASHER 10	49- 36	2	2	
22217-040000	SPRING WASHER 4	48- 83	2	2	
22217-050000	SPRING WASHER 5	15- 15	1		
22217-050000	SPRING WASHER 5	15- 18	1		
22217-060000	SPRING WASHER 6	25- 60	8		
22217-060000	SPRING WASHER 6	37- 22	4	4	
22217-060000	SPRING WASHER 6	47- 19	2	2	
22217-080000	SPRING WASHER 8	51- 11	2	2	
22217-080000	SPRING WASHER 8	1- 41	2		
22217-080000	SPRING WASHER 8	2- 17	4		
22217-080000	SPRING WASHER 8	4- 26	2		
22217-080000	SPRING WASHER 8	4- 28	2		
22217-080000	SPRING WASHER 8	4- 31	2		
22217-080000	SPRING WASHER 8	5- 11	4	4	
22217-080000	SPRING WASHER 8	9- 3	1		
22217-080000	SPRING WASHER 8	10- 26	4		
22217-080000	SPRING WASHER 8	13- 15	1		
22217-080000	SPRING WASHER 8	27- 41		4	
22217-080000	SPRING WASHER 8	30- 26	7		
22217-080000	SPRING WASHER 8	31- 26		7	
22217-080000	SPRING WASHER 8	32- 40	1		
22217-080000	SPRING WASHER 8	33- 9		2	
22217-080000	SPRING WASHER 8	33- 47		1	
22217-080000	SPRING WASHER 8	34- 3	7		
22217-080000	SPRING WASHER 8	34- 68	3		
22217-080000	SPRING WASHER 8	35- 39		7	
22217-080000	SPRING WASHER 8	35- 65		3	
22217-080000	SPRING WASHER 8	37- 37	1	1	
22217-080000	SPRING WASHER 8	37- 53	1	1	
22217-080000	SPRING WASHER 8	38- 23		1	
22217-080000	SPRING WASHER 8	41- 10	10	10	
22217-080000	SPRING WASHER 8	42- 8	6	6	
22217-080000	SPRING WASHER 8	42- 17	1	1	
22217-080000	SPRING WASHER 8	43- 21	9	9	
22217-080000	SPRING WASHER 8	46- 37	4	4	
22217-100000	SPRING WASHER 10	54- 14	2	2	
22217-100000	SPRING WASHER 10	5- 8		1	
22217-100000	SPRING WASHER 10	7 -19	5		

NUMERICAL PART NO. LIST

Part No.	Description	Refer. No.	Q'ty/Unit		Remarks
			YM241	YM241D	
22217-100000	SPRING WASHER 10	22- 29	1	1	
22217-100000	SPRING WASHER 10	23- 4	4		
22217-100000	SPRING WASHER 10	24- 4		4	
22217-100000	SPRING WASHER 10	26- 33		3	
22217-100000	SPRING WASHER 10	28- 12		20	
22217-100000	SPRING WASHER 10	28- 13		16	
22217-100000	SPRING WASHER 10	28- 31		8	
22217-100000	SPRING WASHER 10	32- 8	6		
22217-100000	SPRING WASHER 10	33- 10		6	
22217-100000	SPRING WASHER 10	34- 4	12		
22217-100000	SPRING WAHSE 10	34- 5	4		
22217-100000	SPRING WASHER 10	34- 45	4		
22217-100000	SPRING WASHER 10	35- 3		12	
22217-100000	SPRING WAHSE 10	35- 4		4	
22217-100000	SPRING WASHER 10	35- 40		4	
22217-100000	SPRING WASHER 10	38- 24		4	
22217-100000	SPRING WASHER 10	39- 26	4	4	
22217-100000	SPRING WASHER 10	40- 10	8	8	
22217-100000	SPRING WASHER 10	40- 11	2	2	
22217-100000	SPRING WASHER 10	41- 11	2	2	
22217-100000	SPRING WASHER 10	43- 22	8	8	
22217-100000	SPRING WASHER 10	47- 20	1	1	
22217-100000	SPRING WASHER 10	49- 63	2	2	
22217-100000	SPRING WASHER 10	50- 22	6	6	
22217-100000	SPRING WASHER 10	50- 23	2	2	
22217-120000	SPRING WASHER 12	21- 30	1	1	
22217-120000	SPRING WASHER 12	25- 31	2		
22217-120000	SPRING WASHER 12	28- 32		12	
22217-120000	SPRING WASHER 12	32- 9	6		
22217-120000	SPRING WASHER 12	33- 11		6	
22217-120000	SPRING WASHER 12	34- 6	2		
22217-120000	SPRING WAHSE 12	34- 46	5		
22217-120000	SPRING WASHER 12	35- 5		2	
22217-120000	SPRING WAHSE 12	35- 41		5	
22217-120000	SPRING WASHER 12	44- 15	2	2	
22217-140000	SPRING WASHER 14	52- 37	2	2	
22217-140000	SPRING WASHER 14	29- 27		4	
22217-140000	SPRING WASHER 14	34- 47	3		
22217-140000	SPRING WASHER 14	35- 42		3	
22217-140000	SPRING WASHER 14	37- 54	1	1	

NUMERICAL PART NO. LIST

Part No.	Description	Refer. No.	Q'ty/Unit		Remarks
			YM241	YM241D	
22217-140000	SPRING WASHER 14	43- 23	4	4	
22217-140000	SPRING WASHER 14	47- 21	4	4	
22217-160000	SPRING WASHER 16	53- 7	2	2	
22217-160000	SPRING WASHER 16	55- 12	4		
22217-160000	SPRING WASHER 16	55- 22	4		
22217-160000	SPRING WASHER 16	56- 17		4	
22217-160000	SPRING WASHER 16	56- 27		4	
22217-160000	SPRING WASHER 16	25- 12	4		
22217-160000	SPRING WASHER 16	29- 13		2	
22217-160000	SPRING WASHER 16	44- 16	2	2	
22217-160000	SPRING WASHER 16	58- 25	4	4	
22217-160000	SPRING WASHER 16	58- 35	4	4	
22217-200000	SPRING WASHER 20	30- 27	1		
22217-200000	SPRING WASHER 20	31- 27		1	
22242-000120	CIRCLIP 12-S	37- 23	1	1	
22242-000150	CIRCLIP 15-S	38- 25		1	
22242-000200	CIRCLIP 20-S	36- 11	1	1	
22242-000240	CIRCLIP 24-S	27- 34		4	
22242-000240	CIRCLIP 24-S	38- 26		2	
22242-000240	CIRCLIP 24-S	38- 27		1	
22242-000300	CIRCLIP 30-S	33- 26		1	
22242-000300	CIRCLIP 30-S	39- 6	1	1	
22242-000360	CIRCLIP 36-S	36- 54	1	1	
22242-000450	CIRCLIP 45-S	36- 35	1	1	
22242-000550	CIRCLIP 55-S	29- 28		2	
22252-000170	CIRCLIP 17-H	36- 12	2	2	
22252-000170	CIRCLIP 17-H	36- 48	4	4	
22252-000280	CIRCLIP 28-H	42- 9	1	1	
22252-000420	CIRCLIP 42-H	2- 33	1		
22252-000470	CIRCLIP 47-H	38- 28		1	
22252-000520	CIRCLIP 52-H	38- 29		1	
22252-000680	CIRCLIP 68-H	28- 33		4	
22252-000720	CIRCLIP 72-H	28- 34		2	
22252-001000	CIRCLIP 100-H	28- 35		2	
22272-000040	SNAP RING 4	46- 38	1	1	
22272-000060	SNAP RING 6	3- 53	1		
22272-000060	SNAP RING 6	46- 39	6	6	
22272-000090	SNAP RING 9	46- 40	1	1	
22272-000120	SNAP RING 12	47- 22	2	2	
22272-000190	SNAP RING 19	41- 34	1	1	

NUMERICAL PART NO. LIST

Part No.	Description	Refer. No.	Q'ty/Unit		Remarks
			YM241	YM241D	
22312-080160	PARALLEL PIN 8x16	1- 22	4		
22312-100180	PARALLEL PIN 10x18	28- 14		4	
22312-100180	PARALLEL PIN 10x18	38- 30		2	
22312-100180	PARALLEL PIN 10x18	43- 24	2	2	
22312-160220	PARALLEL PIN 16x22	40- 37	4	4	
22322-030140	TAPER PIN 3x14	3- 51	1		
22322-030160	TAPER PIN 3x16	14- 29	1		
22322-030180	TAPER PIN 3x18	3- 50	1		
22322-030180	TAPER PIN 3x18	14- 28	1		
22351-030012	SPRING PIN 3x12	47- 23	2	2	
22351-030020	SPRING PIN 3x20	37- 24	1	1	
22351-030020	SPRING PIN 3x20	37- 25	1	1	
22351-030020	SPRING PIN 3x20	38- 31		1	
22351-035014	SPRING PIN 3.5x14	34- 48	1		
22351-035014	SPRING PIN 3.5x14	35- 43		1	
22351-035022	SPRING PIN 3.5x22	39- 27	4	4	
22351-035032	SPRING PIN 3.5x32	32- 29	1		
22351-035032	SPRING PIN 3.5x32	33- 36		1	
22351-035032	SPRING PIN 3.5x32	39- 15	1	1	
22351-040012	SPRING PIN 4x12	9- 6	1		
22351-040012	SPRING PIN 4x12	37- 26	3	3	
22351-040014	SPRING PIN 4x14	52- 38	4	4	
22351-040014	SPRING PIN 4x14	46- 41	1	1	
22351-040016	SPRING PIN 4x16	43- 56	1	1	
22351-040016	SPRING PIN 4x16	43- 57	1	1	
22351-040018	SPRING PIN 4x18	37- 38	1	1	
22351-040022	SPRING PIN 4x22	52- 16	2	2	
22351-040022	SPRING PIN 4x22	43- 58	1	1	
22351-040024	SPRING PIN 4x24	52- 7	2	2	
22351-040025	SPRING PIN 4x25	27- 23		1	
22351-050025	SPRING PIN 5x25	46- 42	1	1	
22351-050036	SPRING PIN 5x36	47- 24	1	1	
22351-050040	SPRING PIN 5x40	37- 5	1	1	
22351-050040	SPRING PIN 5x40	40- 26	2	2	
22351-050056	SPRING PIN 5x56	44- 17	1	1	
22351-060014	SPRING PIN 6x14	3- 14	2		
22351-060014	SPRING PIN 6x14	34- 49	1		
22351-060014	SPRING PIN 6x14	35- 44		1	
22351-060016	SPRING PIN 6x16	36- 44	1	1	
22351-060016	SPRING PIN 6x16	44- 18	1	1	



NUMERICAL PART NO. LIST

Part No.	Description	Refer. No.	Q'ty/Unit		Remarks
			YM241	YM241D	
22351-060018	SPRING PIN 6x18	38- 32		1	
22351-060025	SPRING PIN 6x25	39- 28	4	4	
22351-060032	SPRING PIN 6x32	32- 30	1		
22351-060032	SPRING PIN 6x32	33- 37		1	
22351-060032	SPRING PIN 6x32	37- 55	1	1	
22351-060032	SPRING PIN 6x32	39- 16	1	1	
22351-060036	SPRING PIN 6x36	38- 33		1	
22351-060040	SPRING PIN 6x40	41- 35	1	1	
22351-080018	SPRING PIN 8x18	27- 24		2	
22351-080018	SPRING PIN 8x18	32- 10	2		
22351-080018	SPRING PIN 8x18	32- 18	3		
22351-080018	SPRING PIN 8x18	33- 12		2	
22351-080018	SPRING PIN 8x18	33- 21		3	
22351-080018	SPRING PIN 8x18	41- 21	1	1	
22351-080020	SPRING PIN 8x20	28- 15		4	
22351-080020	SPRING PIN 8x20	28- 36		4	
22351-080020	SPRING PIN 8x20	28- 37		4	
22351-080040	SPRING PIN 8x40	40- 27	2	2	
22351-100020	SPRING PIN 10x20	34- 7	8		
22351-100020	SPRING PIN 10x20	35- 6		8	
22351-100020	SPRING PIN 10x20	47- 25	2	2	
22360-060000	SNAP PIN 6	14- 37	1		
22360-080000	SNAP PIN 8	51- 12	1	1	
22360-160000	SNAP PIN 16	52- 17	1	1	
22360-160000	SNAP PIN 16	52- 24	1	1	
22417-160180	COTTER PIN 1.6x18	21- 14	4	4	
22417-160180	COTTER PIN 1.6x18	21- 31	4	4	
22417-160180	COTTER PIN 1.6x18	50- 41	8	8	
22417-200120	COTTER PIN 2x12	34- 64	1		
22417-200120	COTTER PIN 2x12	35- 61		1	
22417-200120	COTTER PIN 2x12	49- 37	2	2	
22417-200200	COTTER PIN 2x20	51- 13	1	1	
22417-200200	COTTER PIN 2x20	14- 4	4		
22417-200200	COTTER PIN 2x20	14- 40	2		
22417-200300	COTTER PIN 2x30	32- 41	2		
22417-200300	COTTER PIN 2x30	33- 48		2	
22417-200300	COTTER PIN 2x30	41- 36	4	4	
22417-250250	COTTER PIN 2.5x25	25- 52	4		
22417-250400	COTTER PIN 2.5x40	27- 11		1	
22417-300200	COTTER PIN 3x20	46- 43	10	10	

NUMERICAL PART NO. LIST

Part No.	Description	Refer. No.	Q'ty/Unit		Remarks
			YM241	YM241D	
22417-300250	COTTER PIN 3x25	25- 45	1		
22417-300250	COTTER PIN 3x25	25- 51	1		
22417-300250	COTTER PIN 3x25	26- 12		1	
22417-300250	COTTER PIN 3x25	26- 18		1	
22417-300250	COTTER PIN 3x25	30- 46	1		
22417-300250	COTTER PIN 3x25	30- 56	1		
22417-300250	COTTER PIN 3x25	31- 46		2	
22417-300280	COTTER PIN 3x28	37- 39	1	1	
22417-300280	COTTER PIN 3x28	37- 56	1	1	
22417-300350	COTTER PIN 3x35	52- 39	2	2	
22417-400400	COTTER PIN 4x40	26- 27		1	
22417-400450	COTTER PIN 4x45	25- 27	2		
22417-450600	COTTER PIN 4.5x60	23- 16	1		
22451-100000	WIRE 1.0	14- 34	2		
22512-070180	KEY 7x7x18	6- 3	1		
22512-070220	KEY 7x7x22	29- 14		2	
22512-070242	KEY 7x7x24	7- 6	1		
22512-070282	KEY 7x7x28	7- 5	1		
22512-070400	KEY 7x7x40	41- 37	1	1	
22512-100340	KEY 10x8x34	25- 28	2		
22512-100362	KEY 10x8x36	7- 4	1		
22522-030100	WOODRUFF KEY 3x10	9- 4	1		
22522-030130	WOODRUFF KEY 3x13	46- 44	3	3	
23010-038000	CLAMP 38	10- 22	6		
23010-050000	CLAMP 50	26- 34		1	
23010-055000	CLAMP 55	26- 35		1	
23061-070035	PIPE 7x35	49- 38	3	3	
23061-070035	PIPE 7x35	50- 24	5	5	
23061-070035	PIPE 7x35	50- 25	2	2	
23061-070230	PIPE 7x230	10- 30	1		
23065-090560	PIPE 9x560	1- 37	1		
23414-060000	PACKING 6	2- 38	3		
23414-060000	PACKING 6	19- 35	3		
23414-080000	PACKING 8	2- 7	5		
23414-080000	PACKING 8	9- 21	4		
23414-080000	PACKING 8	19- 36	13		
23414-080000	PACKING 8	34- 50	1		
23414-080000	PACKING 8	35- 45		1	
23414-080012	PACKING 8	13- 38	4		
23414-100000	PACKING 10	9- 20	2		

NUMERICAL PART NO. LIST

Part No.	Description	Refer. No.	Q'ty/Unit		Remarks
			YM241	YM241D	
23414-100000	PACKING 10	19- 37	2		
23414-180023	PACKING 18	42- 36	2	2	
23414-180023	PACKING 18	43- 25	1	1	
23414-200026	PACKING 20	43- 47	1	1	
23414-200026	PACKING 20	43- 71	1	1	
23418-060000	PACKING 6	13- 4	2		
23873-010000	TAPER PLUG PT1/8	28- 6		1	
23873-010000	TAPER PLUG PT1/8	28- 6		1	
23873-010000	TAPER PLUG PT1/8	38- 34		1	
23873-010000	TAPER PLUG PT1/8	43- 4	1	1	
23873-010000	TAPER PLUG PT1/8	43- 9	4	4	
23873-010000	TAPER PLUG PT1/8	43- 15	3	3	
23873-010000	TAPER PLUG PT1/8	45- 24	2	2	
23873-020000	TAPER PLUG PT1/4	3- 24	2		
23873-040000	TAPER PLUG PT1/2	3- 5	1		
23883-100002	PLUG M10	1- 3	1		
24101-060044	BALL BEARING #6004	2- 29	2		
24101-060054	BALL BEARING #6005	38- 35		1	
24101-060084	BALL BEARING #6008	29- 29		2	
24101-060094	BALL BEARING #6009	27- 12		1	
24101-060094	BALL BEARING #6009	27- 25		1	
24101-060124	BALL BEARING #6012	39- 7	1	1	
24101-060124	BALL BEARING #6012	39- 17	1	1	
24101-060134	BALL BEARING #6013	29- 15		2	
24101-062044	BALL BEARING #6204	38- 36		1	
24101-062044	BALL BEARING #6204	38- 37		1	
24101-062054	BALL BEARING #6205	29- 16		2	
24101-062054	BALL BEARING #6205	36- 49	1	1	
24101-062054	BALL BEARING #6205	36- 55	1	1	
24101-062054	BALL BEARING #6205	38- 38		1	
24101-062064	BALL BEARING #6206	6- 8	1		
24101-062074	BALL BEARING #6207	27- 35		2	
24101-062074	BALL BEARING #6207	36- 56	1	1	
24101-062094	BALL BEARING #6209	40- 49	2	2	
24101-062114	BALL BEARING #6211	29- 30		2	
24101-063044	BALL BEARING #6304	36- 13	2	2	
24101-063044	BALL BEARING #6304	36- 50	1	1	
24104-063074	BALL BEARING #6307UU	40- 32	2	2	
24121-060064	BALL BEARING #6006N	33- 27		1	
24190-080003	BALL 1/4	43- 67	1	1	

NUMERICAL PART NO. LIST

Part No.	Description	Refer. No.	Q'ty/Unit		Remarks
			YM241	YM241D	
24190-100001	BALL 5/16	9- 12	1		
24190-100001	BALL 5/16	26- 28		12	
24190-100001	BALL 5/16	37- 27	3	3	
24190-100001	BALL 5/16	37- 40	1	1	
24190-100001	BALL 5/16	37- 57	1	1	
24190-100001	BALL 5/16	38- 39		1	
24190-110001	BALL 11/32	21- 15	1	1	
24211-035002	NUT M35	29- 31		2	
24311-000050	O-RING 5-P	45- 25	1	1	
24311-000050	O-RING 5-P	45- 26	1	1	
24311-000060	O-RING 6-P	43- 59	1	1	
24311-000070	O-RING 7-P	3- 49	1		
24311-000070	O-RING 7-P	14- 30		1	
24311-000070	O-RING 7-P	19- 30		2	
24311-000090	O-RING 9-P	43- 60	1	1	
24311-000090	O-RING 9-P	46- 45	3	3	
24311-000110	O-RING 11-P	37- 28	3	3	
24311-000120	O-RING 12-P	22- 30	1	1	
24311-000120	O-RING 12-P	43- 48	1	1	
24311-000120	O-RING 12-P	43- 68	1	1	
24311-000120	O-RING 12-P	45- 27	1	1	
24311-000120	O-RING 12-P	45- 28	1	1	
24311-000140	O-RING 14-P	1- 29	1		
24311-000140	O-RING 14-P	3- 55		2	
24311-000140	O-RING 14-P	19- 31		2	
24311-000140	O-RING 14-P	34- 51		3	
24311-000140	O-RING 14-P	35- 46		3	
24311-000140	O-RING 14-P	37- 58	1	1	
24311-000150	O-RING 15-P	46- 46	3	3	
24311-000160	O-RING 16-P	28- 7		1	
24311-000160	O-RING 16-P	28- 38		2	
24311-000160	O-RING 16-P	34- 52	1		
24311-000160	O-RING 16-P	35- 47		1	
24311-000160	O-RING 16-P	37- 41	1	1	
24311-000160	O-RING 16-P	37- 59	1	1	
24311-000160	O-RING 16-P	38- 40		1	
24311-000160	O-RING 16-P	38- 41		1	
24311-000160	O-RING 16-P	40- 28	2	2	
24311-000200	O-RING 20-P	42- 37	2	2	
24311-000210	O-RING 21-P	27- 13		1	

NUMERICAL PART NO. LIST

Part No.	Description	Refer. No.	Q'ty/Unit		Remarks
			VM241	VM241D	
24311-000210	O-RING 21-P	38- 42		1	
24311-000220	O-RING 22-P	28- 16		1	
24311-000220	O-RING 22-P	28- 17		1	
24311-000290	O-RING 29-P	40- 33	2	2	
24311-000450	O-RING 45-P	22- 9	1	1	
24311-000700	O-RING 70-P	44- 3	1	1	
24311-240100	O-RING 10A-P	13- 8	1		
24315-000070	O-RING 7-P	45- 29	1	1	
24315-000110	O-RING 11-P	43- 26	2	2	
24315-000110	O-RING 11-P	45- 30	3	3	
24315-000140	O-RING 14-P	43- 27	4	4	
24321-000250	O-RING 25-G	32- 11	2		
24321-000300	O-RING 30-G	42- 38	2	2	
24321-000350	O-RING 35-G	1- 13	1		
24321-000350	O-RING 35-G	2- 10	(1)		
24321-000350	O-RING 35-G	19- 32	1		
24321-000400	O-RING 40-G	29- 32		2	
24321-000450	O-RING 45-G	40- 50	2	2	
24321-000500	O-RING 50-G	30- 28	1		
24321-000500	O-RING 50-G	31- 28		1	
24321-000500	O-RING 50-G	34- 65	1		
24321-000500	O-RING 50-G	35- 62		1	
24321-000550	O-RING 55-G	44- 19	4	4	
24321-000600	O-RING 60-G	26- 36		1	
24321-000600	O-RING 60-G	26- 37		1	
24321-000600	O-RING 60-G	34- 66	1		
24321-000600	O-RING 60-G	35- 63		1	
24321-000850	O-RING 85-G	28- 39		2	
24321-001150	O-RING 115-G	39- 29	2	2	
24321-001250	O-RING 125-G	38- 43		1	
24325-000750	O-RING 75-G	43- 28	1	1	
24341-000250	O-RING 25-S	27- 14		1	
24341-000250	O-RING 25-S	32- 12	2		
24341-000320	O-RING 32-S	34- 53	1		
24341-000320	O-RING 32-S	35- 48		1	
24341-000630	O-RING 63-S	27- 42		1	
24550-012150	BUSH 12x15	46- 23	2	2	
24550-018200	BUSH 18x20	47- 12	1	1	
24761-010000	GREASE NIPPLE M6F	21- 32	1	1	
24761-010000	GREASE NIPPLE M6F	23- 17	2		

NUMERICAL PART NO. LIST

Part No.	Description	Refer. No.	Q'ty/Unit		Remarks
			VM241	VM241D	
24761-010000	GREASE NIPPLE M6F	32- 42	1		
24761-010000	GREASE NIPPLE M6F	33- 13		2	
24761-010000	GREASE NIPPLE M6F	33- 49		1	
24761-010000	GREASE NIPPLE M6F	41- 38	1	1	
24761-060000	GREASE NIPPLE MT6x1	52- 8	1	1	
24761-060000	GREASE NIPPLE MT6x1	52- 18	1	1	
24761-060000	GREASE NIPPLE MT6x1	52- 40	2	2	
24761-060000	GREASE NIPPLE MT6x1	30- 47	1		
24761-060000	GREASE NIPPLE MT6x1	30- 55	1		
24761-060000	GREASE NIPPLE MT6x1	31- 47		2	
24764-010000	GREASE NIPPLE M6F	47- 26	1	1	
26011-060122	BOLT M6x12	49- 58	3	3	
26013-060162	BOLT M6x16	51- 14	2	2	
26013-060162	BOLT M6x16	49- 39	4	4	
26013-060352	BOLT M6x35	42- 39	4	4	
26013-060402	BOLT M6x40	42- 40	3	3	
26013-080122	BOLT M8x12	21- 37	2	2	
26013-080162	BOLT M8x16	22- 16	4	4	
26013-080162	BOLT M8x16	32- 19	6		
26013-080162	BOLT M8x16	33- 22		6	
26013-080162	BOLT M8x16	34- 54	2		
26013-080162	BOLT M8x16	35- 49		2	
26013-080202	BOLT M8x20	21- 33	1	1	
26013-080202	BOLT M8x20	42- 41	10	10	
26013-080222	BOLT M8x22	40- 51	6	6	
26013-080252	BOLT M8x25	51- 15	4	4	
26013-100162	BOLT M10x16	48- 67	4	4	
26013-100162	BOLT M10x16	49- 40	2	2	
26013-100202	BOLT M10x20	42- 42	1	1	
26013-100202	BOLT M10x20	49- 57	2	2	
26013-100202	BOLT M10x20	50- 26	8	8	
26013-100202	BOLT M10x20	50- 42	4	4	
26013-100252	BOLT M10x25	49- 41	2	2	
26013-100252	BOLT M10x25	50- 43	4	4	
26013-100282	BOLT M10x28	26- 3		6	
26013-100382	BOLT M10x38	42- 43	1	1	
26013-120302	BOLT M12x30	23- 5	14		
26013-120302	BOLT M12x30	24- 5		14	
26013-120302	BOLT M12x30	24- 12		4	
26013-120402	BOLT M12x40	23- 18	8		

NUMERICAL PART NO. LIST

Part No.	Description	Refer. No.	Q'ty/Unit		Remarks
			YM341	YM241D	
26013-120402	BOLT M12x40	42- 44	2	2	
26013-140252	BOLT M14x25	29- 33		8	
26013-140252	BOLT M14x25	34- 55	4		
26013-140252	BOLT M14x25	35- 50		4	
26013-140302	BOLT M14x30	53- 8	4	4	
26021-050122	SCREW M5x12	49- 42	6	6	
26116-050142	BOLT M5x14	15- 17	1		
26116-050142	BOLT M5x14	21- 38	1	1	
26116-060082	BOLT M6x8	47- 27	2	2	
26116-060102	BOLT M6x10	3- 47	4		
26116-060102	BOLT M6x10	13- 22	2		
26116-060122	BOLT M6x12	10- 45	3		
26116-100202	BOLT M10x20	49- 57	2	2	
26116-060122	BOLT M6x12	25- 61	8		
26116-060142	BOLT M6x14	1- 34	4		
26116-060142	BOLT M6x14	1- 36	2		
26116-060142	BOLT M6x14	45- 33	1	1	
26116-060162	BOLT M6x16	2- 36	2		
26116-060162	BOLT M6x16	37- 29	4	4	
26116-060162	BOLT M6x16	42- 45	2	2	
26116-060202	BOLT M6x20	10- 13	4		
26116-060202	BOLT M6x20	10- 39	1		
26116-060222	BOLT M6x22	9- 7	3		
26116-060322	BOLT M6x32	16- 36	2		
26116-060326	BOLT M6x32	2- 37	1		
26116-060402	BOLT M6x40	10- 8	4		
26116-080122	BOLT M8x12	2- 6	2		
26116-080122	BOLT M8x12	3- 17	3		
26116-080122	BOLT M8x12	5- 16	2		
26116-080122	BOLT M8x12	10- 50	2		
26116-080122	BOLT M8x12	18- 8	2		
26116-080142	BOLT M8x14	3- 18	1		
26116-080142	BOLT M8x14	22- 31	1	1	
26116-080162	BOLT M8x16	2- 11	(3)		
26116-080162	BOLT M8x16	5- 17	2		
26116-080162	BOLT M8x16	10- 25	4		
26116-080162	BOLT M8x16	22- 17	2	2	
26116-080162	BOLT M8x16	37- 42	1	1	
26116-080162	BOLT M8x16	37- 60	1	1	
26116-080162	BOLT M8x16	38- 44		1	

NUMERICAL PART NO. LIST

Part No.	Description	Refer. No.	Q'ty/Unit		Remarks
			YM341	YM241D	
26116-080182	BOLT M8x18	15- 9	2		
26116-080182	BOLT M8x18	46- 47	1	1	
26116-080202	BOLT M8x20	4- 25	2		
26116-080202	BOLT M8x20	33- 14		2	
26116-080202	BOLT M8x20	34- 69	3		
26116-080202	BOLT M8x20	35- 66		3	
26116-080202	BOLT M8x20	50- 27	2	2	
26116-080222	BOLT M8x22	1- 40	2		
26116-080222	BOLT M8x22	2- 12	(1)		
26116-080222	BOLT M8x22	27- 43		4	
26116-080222	BOLT M8x22	30- 29	7		
26116-080222	BOLT M8x22	31- 29		7	
26116-080222	BOLT M8x22	35- 51		3	
26116-080252	BOLT M8x25	1- 31	16		
26116-080252	BOLT M8x25	4- 27	2		
26116-080252	BOLT M8x25	4- 29	2		
26116-080252	BOLT M8x25	20- 6	2	2	
26116-080252	BOLT M8x25	22- 18	2	2	
26116-080252	BOLT M8x25	41- 12	10	10	
26116-080302	BOLT M8x30	15- 8	3		
26116-080302	BOLT M8x30	20- 7	4	4	
26116-080352	BOLT M8x35	1- 14	2		
26116-080352	BOLT M8x35	43- 29	1	1	
26116-080402	BOLT M8x40	10- 16	1		
26116-080402	BOLT M8x40	32- 43	1		
26116-080402	BOLT M8x40	33- 50		1	
26116-080452	BOLT M8x45	10- 15	1		
26116-080452	BOLT M8x45	35- 52		4	
26116-080452	BOLT M8x45	43- 30	4	4	
26116-080502	BOLT M8x50	51- 16	2	2	
26116-080502	BOLT M8x50	2- 20	2		
26116-080502	BOLT M8x50	22- 19	2	2	
26116-080602	BOLT M8x60	2- 21	2		
26116-080602	BOLT M8x60	46- 48	2	2	
26116-080702	BOLT M8x70	10- 9	2		
26116-080702	BOLT M8x70	13- 39	1		
26116-080702	BOLT M8x70	46- 28	2	2	
26116-081002	BOLT M8x100	2- 19	5		
26116-081052	BOLT M8x105	4- 30	2		
26116-100162	BOLT M10x16	54- 15	2		

NUMERICAL PART NO. LIST

Part No.	Description	Refer. No.	Q'ty/Unit		Remarks
			YM241	YM241D	
26116-100162	BOLT M10x16	28- 40		2	
26116-100202	BOLT M10x20	23- 6	4		
26116-100202	BOLT M10x20	24- 6		4	
26116-100202	BOLT M10x20	49- 57	2	2	
26116-100252	BOLT M10x25	7- 18	5		
26116-100252	BOLT M10x25	28- 18		20	
26116-100252	BOLT M10x25	51- 18	1	1	
26116-100282	BOLT M10x28	28- 19		16	
26116-100302	BOLT M10x30	28- 41		4	
26116-100302	BOLT M10x30	38- 45		4	
26116-100302	BOLT M10x30	39- 30	4	4	
26116-100302	BOLT M10x30	40- 12	2	2	
26116-100302	BOLT M10x30	40- 21	1	1	
26116-100322	BOLT M10x32	1- 49	9		
26116-100352	BOLT M10x35	40- 13	8	8	
26116-100352	BOLT M10x35	43- 31	3	3	
26116-100452	BOLT M10x45	28- 42		4	
26116-100552	BOLT M10x55	34- 56	4		
26116-100552	BOLT M10x55	35- 53		4	
26116-100652	BOLT M10x65	5- 6		1	
26116-100652	BOLT M10x65	32- 13	4		
26116-100652	BOLT M10x65	33- 15		4	
26116-100702	BOLT M10x70	39- 18	6	6	
26116-100802	BOLT M10x80	32- 14	2		
26116-100802	BOLT M10x80	33- 16		2	
26116-120282	BOLT M12x28	44- 20	2	2	
26116-120352	BOLT M12x35	28- 43		12	
26116-120352	BOLT M12x35	32- 15	6		
26116-120352	BOLT M12x35	33- 17		6	
26116-120352	BOLT M12x35	34- 57	5		
26116-120352	BOLT M12x35	35- 54		5	
26116-120452	BOLT M12x45	21- 34	1	1	
26116-120602	BOLT M12x60	25- 32	2		
26116-120652	BOLT M12x65	2- 30	1		
26116-160652	BOLT M16x65	25- 13	4		
26116-160902	BOLT M16x90	53- 9	2	2	
26117-050169	BOLT M5x16	17- 18	1		
26126-080252	BOLT M8x25	42- 10	6	6	
26126-100162	BOLT M10x16	26- 38		3	
26126-140452	BOLT M14x45	43- 32	2	2	

NUMERICAL PART NO. LIST

Part No.	Description	Refer. No.	Q'ty/Unit		Remarks
			YM241	YM241D	
26126-140452	BOLT M14x45	47- 28	2	2	
26126-140552	BOLT M14x55	47- 29	2	2	
26126-140652	BOLT M14x65	43- 33	2	2	
26216-080142	STUD M8x14	2- 5	2		
26216-080202	STUD M8x20	34- 8	3		
26216-080222	STUD M8x22	1- 16	2		
26216-080222	STUD M8x22	2- 14	4		
26216-080222	STUD M8x22	5- 10	4	4	
26216-080452	STUD M8x45	43- 5	2	2	
26216-080502	STUD M8x50	34- 9	4		
26216-080602	STUD M8x60	3- 20	4		
26216-080752	STUD M8x75	3- 22	4		
26216-100252	STUD M10x25	34- 10	8		
26216-100252	STUD M10x25	35- 7		8	
26216-100302	STUD M10x30	34- 11	4		
26216-100302	STUD M10x30	35- 8		4	
26216-100322	STUD M10x32	34- 17	5		
26216-100322	STUD M10x32	35- 13		5	
26216-100452	STUD M10x45	34- 12	4		
26216-100452	STUD M10x45	35- 9		4	
26216-120322	STUD M12x32	34- 13	2		
26216-120322	STUD M12x32	35- 10		2	
26286-100162	STUD M10x16	33- 18		2	
26346-040002	U-NUT M4	42- 57	2	2	
26346-050002	U-NUT M5	48- 93	1	1	
26346-060002	U-NUT M6	34- 67	1		
26346-060002	U-NUT M6	35- 64		1	
26346-120002	U-NUT M12	40- 34	2	2	
26356-120002	U-NUT M12	30- 38	1		
26356-120002	U-NUT M12	31- 38		1	
26450-080182	BROACHED BOLT M8x18	27- 26		6	
26450-080202	BROACHED BOLT M8x20	45- 35	3	3	
26557-030062	SCREW M3x6	22- 8	2	2	
26557-040082	SCREW M4x8	17- 17	3		
26557-040122	SCREW M4x12	16- 28	2		
26557-040202	SCREW M4x20	17- 16	2		
26557-040202	SCREW M4x20	17- 21	3		
26557-050122	SCREW M5x12	49- 43	4	4	
26557-050122	SCREW M5x12	49- 44	6	6	
26557-050122	SCREW M5x12	49- 45	4	4	

NUMERICAL PART NO. LIST

Part No.	Description	Refer. No.	Q'ty/Unit		Remarks
			VM201	VM201D	
26557-050162	SCREW M5x16	48- 94	1	1	
26557-060082	SCREW M6x8	13- 21	1		
26557-060082	SCREW M6x8	14- 22	1		
26557-060082	SCREW M6x8	18- 9	2		
26557-060102	SCREW M6x10	2- 25	2		
26557-060122	SCREW M6x12	21- 16	2	2	
26557-060122	SCREW M6x12	48- 95	2	2	
26557-060122	SCREW M6x12	50- 28	4	4	
26557-060302	SCREW M6x30	48- 89	2	2	
26577-080202	SCREW M8x20	48- 30	1	1	
26577-080252	SCREW M8x25	22- 20	2	2	
26587-060162	SCREW M6x16	49- 58	3	3	
26587-060162	SCREW M6x16	50 -29	8	8	
26587-060202	SCREW M6x20	48- 37	2	2	
26587-080122	SCREW M8x12	6- 9	1		
26587-080122	SCREW M8x12	50- 30	4	4	
26587-080162	SCREW M8x16	48- 79	1	1	
26587-080162	SCREW M8x16	49- 59	2	2	
26635-080002	WING NUT M8	46- 49	1	1	
26657-060002	CAP NUT M6	14- 41	2		
26667-080002	CAP NUT M8	14- 16	1		
26716-040002	NUT M4	42- 56	1	1	
26716-040002	NUT M4	48- 84	2	2	
26716-060002	NUT M6	21- 17	2	2	
26716-080002	NUT M8	1- 17	2		
26716-080002	NUT M8	2- 15	6		
26716-080002	NUT M8	3- 21	4		
26716-080002	NUT M8	3- 23	4		
26716-080002	NUT M8	5- 14	4	4	
26716-080002	NUT M8	9- 5	1		
26716-080002	NUT M8	15- 10	2		
26716-080002	NUT M8	21- 18	2	2	
26716-080002	NUT M8	22- 21	4	4	
26716-080002	NUT M8	34- 14	7		
26716-080002	NUT M8	43- 34	4	4	
26716-080002	NUT M8	46- 50	7	7	
26716-080002	NUT M8	46- 50	5	5	
26716-080002	NUT M8	49- 46	2	2	
26716-100002	NUT M10	54- 16	2		
26716-100002	NUT M10	5- 7	1		

NUMERICAL PART NO. LIST

Part No.	Description	Refer. No.	Q'ty/Unit		Remarks
			VM201	VM201D	
26716-100002	NUT M10	21- 19	2	2	
26716-100002	NUT M10	22- 32	1	1	
26716-100002	NUT M10	23- 7	4		
26716-100002	NUT M10	24- 7		4	
26716-100002	NUT M10	32- 44	1		
26716-100002	NUT M10	33- 51		1	
26716-100002	NUT M10	34- 15	16		
26716-100002	NUT M10	35- 11		16	
26716-100002	NUT M10	40- 22	1	1	
26716-100002	NUT M10	41- 13	2	2	
26716-100002	NUT M10	41- 39	2	2	
26716-100002	NUT M10	43- 35	5	5	
26716-100002	NUT M10	50- 31	6	6	
26716-100002	NUT M10	50- 32	2	2	
26716-120002	NUT M12	1- 48	2		
26716-120002	NUT M12	23- 19	8		
26716-120002	NUT M12	34- 16	2		
26716-120002	NUT M12	35- 12		2	
26716-120002	NUT M12	37- 43	1	1	
26716-120002	NUT M12	38- 46		1	
26716-120002	NUT M12	46- 51	2	2	
26716-120002	NUT M12	46- 51	1	1	
26716-120002	NUT M12	49- 47	2	2	
26716-140002	NUT M14	52- 41	2	2	
26716-140002	NUT M14	29- 34		4	
26716-140002	NUT M14	47- 32	1	1	
26716-160002	NUT M16	53- 10	2	2	
26716-160002	NUT M16	25- 14	4		
26716-160002	NUT M16	29- 17		2	
26726-120002	NUT M12	46- 54	1	1	
26726-140002	NUT M14	47- 30	2	2	
26726-140002	NUT M14	47- 30	1	1	
26726-140002	NUT M14	47- 31	1	1	
26736-140002	NUT M14	34- 58	3		
26736-140002	NUT M14	35- 55		3	
26736-140002	NUT M14	37- 61	1	1	
26736-160002	NUT M16	44- 21	2	2	
26736-200002	NUT M20	30- 30	1		
26736-200002	NUT M20	31- 30		1	
26756-050002	LOCK NUT M5	3- 48	2		

NUMERICAL PART NO. LIST

Part No.	Description	Refer. No.	Q'ty/Unit		Remarks
			YM241	YM241D	
26756-050002	LOCK NUT M5	14- 14	2		
26756-050002	LOCK NUT M5	14- 15	1		
26756-050002	LOCK NUT M5	15- 16	1		
26756-050002	LOCK NUT M5	21- 39	1	1	
26756-060002	LOCK NUT M6	45- 31	2	2	
26756-060002	LOCK NUT M6	45- 31	1	1	
26756-080002	LOCK NUT M8	3- 29	2		
26756-080002	LOCK NUT M8	3- 33	2		
26756-080002	LOCK NUT M8	10- 34	4		
26756-080002	LOCK NUT M8	15- 5	1		
26756-080002	LOCK NUT M8	46- 52	2	2	
26756-100002	LOCK NUT M10	46- 53	2	2	
26756-140002	LOCK NUT M14	52- 42	2	2	
26756-200002	LOCK NUT M20	52- 19	1	1	
26756-240002	LOCK NUT M24	52- 9	1	1	
26776-100002	LOCK NUT M10	30- 31	1		
26776-100002	LOCK NUT M10	31- 31		1	
26776-120002	LOCK NUT M12	48- 31	1	1	
26786-120002	LOCK NUT M12	48- 49	2	2	
26786-120002	LOCK NUT M12	48- 57	2	2	
26817-160002	CASTLE NUT M16	52- 43	2	2	
26837-100002	CASTLE NUT M10	25- 53	4		
26877-270002	CASTLE NUT M27	23- 20	1		
27233-350000	PLUG 35	5- 13	1	1	
27233-400000	PLUG 40	1- 20	1		
27233-400000	PLUG 40	1- 25	1		
27233-400000	PLUG 40	23- 21	1		
27310-080000	COTTER, valve spring	3- 12	4		
27310-080001	COTTER, valve spring	3- 12	4		
28110-080100	WRENCH 8x10	54- 6	1	1	
28110-100130	WRENCH 10x13	54- 7	1	1	
28110-170190	WRENCH 17x19	54- 8	1	1	
28110-220240	WRENCH 22x24	54- 9	1	1	
28110-260320	WRENCH 26x32	54- 10	1	1	
28110-270300	WRENCH 27x30	54- 11	1	1	
28170-001500	PLIER 150	54- 12	1	1	
43400-500390	SEAL WASHER 6	13- 29	1		
43400-500400	SEAL WASHER 6	14- 42	2		
43400-500400	SEAL WASHER 6	19- 33	2		
43400-500410	SEAL WASHER 8	1- 18	2		

NUMERICAL PART NO. LIST

Part No.	Description	Refer. No.	Q'ty/Unit		Remarks
			YM241	YM241D	
43400-500410	SEAL WASHER 8	14- 17	2		
43400-500410	SEAL WASHER 8	19- 34	4		
711100-51540	ROLLER ASS'Y, plunger guide	11- 9	2		
721257-55540	COCK ASS'Y, fuel	13- 2	1		
Z- 724160-01612	HOUSING ASS'Y, gears	2- 1	1		
724240-51530	RACK ASS'Y, fuel control	11- 20	1		
724450-11650	ARM ASS'Y, rocker	3- 26	2		
724450-11660	ARM ASS'Y, rocker	3- 30	2		
724450-23100	ROD ASS'Y, connecting	8- 9	2		
724450-61520	SUPPORT ASS'Y, governor weight	14- 1	1		
Z- 724460-11521	BONNET ASS'Y, cyl.	3- 37	1		
Z- 724465-01541	PAN ASS'Y, lub. oil	1- 26	1		
Z- 724465-01561	BLOCK ASS'Y, cylinder	1- 1	1		
724465-02500	HOUSING ASS'Y, main bearing	7- 10	1		
724465-14580	CAMSHAFT ASS'Y	6- 1	1		
724550-51520	GUIDE ASS'Y, plunger	11- 7	2		
724761-51701	PUMP ASS'Y, fuel injection	11- 1	1		
724763-01900	LINER w/PACKING, cyl.	1- 42	2		
724763-22500	RING SET, piston	8- 3	2		
Z- 724764-11700	HEAD ASS'Y, cylinder	3- 1	1		
724764-21700	CRANKSHAFT ASS'Y	7- 1	1		
724764-92600	GASKET KIT	19- 1	1		
724767-13700	2nd SILENCER ASS'Y, exhaust	5- 2		1	
724768-22721	PISTON w/RING	8- 1	2		
724770-53100	VALVE ASS'Y, fuel injection	12- 1	2		
724790-32100	PUMP ASS'Y, lub. oil	9- 1	1		
774307-51490	PINION(B), fuel control	11- 23	1		
794080-12950	TIRE w/TUBE 4.00-15	55- 3	2		
794080-34930	TIRE w/TUBE 9-24	55- 13	1		
794080-34930	TIRE w/TUBE 9-24	55- 23	1		
794080-34930	TIRE w/TUBE 9-24	56- 18		1	
794080-34930	TIRE w/TUBE 9-24	56- 28		1	
794081-12950	TIRE w/TUBE 5.00-15	58- 3	2		
794081-54101	LIGHT ASS'Y, work	48- 69	1	1	
794130-71410	PIN ASS'Y, ball socket	52- 3	2	2	
794130-71410	PIN ASS'Y, ball socket	52- 11	1	1	
794130-71410	PIN ASS'Y, ball socket	52- 21	1	1	
794130-71410	PIN ASS'Y, ball socket	52- 26	4	4	
794130-71410	PIN ASS'Y, ball socket	53- 1	2	2	
794150-21400	DISC ASS'Y, clutch	32- 16	1		

NUMERICAL PART NO. LIST

Part No.	Description	Refer. No.	Qty/Unit		Remarks
			YM241	YM241D	
794150-21400	DISC ASS'Y, clutch	33- 19		1	
794150-21700	PLATE ASS'Y, pressure	32- 17	1		
794150-21700	PLATE ASS'Y, pressure	33- 20		1	
794150-22150	SLEEVE w/BEARING ASS'Y	32- 21	1		
794150-22150	SLEEVE w/BEARING ASS'Y	33- 28		1	
794150-25900	GEAR ASS'Y, reverse	36- 40	1	1	
X- 794150-27100	LEVER ASS'Y, gear shift	37- 2	1	1	
X- 794150-37471	PEDAL(R)	41- 22	1	1	
794150-82100	TOOL KIT	54- 1	1	1	
X- 794161-21110	HOUSING ASS'Y, clutch	32- 1	1		
P- 794166-14700	TIRE ASS'Y(L), front wheel	56- 1		1	
P- 794166-14800	TIRE ASS'Y(R), front wheel	56- 6		1	
P- 794171-14700	TIRE ASS'Y(L), front wheel	58- 6		1	
P- 794171-14800	TIRE ASS'Y(R), front wheel	58- 11		1	
P- 794240-34800	WHEEL ASS'Y DCW7x24W	55- 7	1		
P- 794240-34800	WHEEL ASS'Y DCW7x24W	55- 17	1		
P- 794240-34800	WHEEL ASS'Y DCW7x24W	56- 12		1	
P- 794240-34800	WHEEL ASS'Y DCW7x24W	56- 22		1	
P- 794240-35100	TIRE ASS'Y(L), rear wheel	55- 6	1		
P- 794240-35100	TIRE ASS'Y(L), rear wheel	56- 11		1	
P- 794240-35110	TIRE ASS'Y(R), rear wheel	55- 16	1		
P- 794240-35110	TIRE ASS'Y(R), rear wheel	56- 21		1	
P- 794240-35210	TIRE ASS'Y(L), rear wheel	58- 16	1	1	
P- 794240-35220	TIRE ASS'Y(R), rear wheel	58- 26	1	1	
P- 794242-12900	TIRE ASS'Y, front wheel	55- 1	2		
X- 794284-72100	LINK ASS'Y(R), lift	52- 10	1	1	
X- 794284-72210	LINK ASS'Y(L), lift	52- 20	1	1	
X- 794284-73110	LINK ASS'Y, lower	52- 25	2	2	
X- 794284-74600	CHAIN ASS'Y, check	52- 28	2	2	
X- 794286-71100	LINK ASS'Y, top	52- 1	1	1	
X- 794730-57122	TIE-ROD END ASS'Y(RL)	25- 40	1		
X- 794730-57122	TIE-ROD END ASS'Y(RL)	26- 7		1	
X- 794730-57122	TIE-ROD END ASS'Y(RL)	30- 51	1		
X- 794730-57132	TIE-ROD END ASS'Y(LR)	25- 46	1		
X- 794730-57132	TIE-ROD END ASS'Y(LR)	26- 13		1	