

0CD10-M91800EN

PREFACE

1. This parts catalog is the 1st edition of 3TNV76-HGB2B export engine for generator Model "YEG20THS"

Pub.No. : 000Y00D9180

Published : October,2006

2. Model name

Engine model	Vehicle		Vehicle made by
	Products	Model name	
3TNV76-HGB2B	SOUNDPROOF 2P GENERATOR	YEG20THS	TOYO DENKI INDUSTRIAL CO.,LTD.

Contents

Fig. No. Fig. Name

3TNV76-HGB2B

1. CYLINDER BLOCK
2. GEAR HOUSING
3. FLYWHEEL HOUSING & OIL SUMP
4. CYLINDER HEAD & BONNET
5. AIR CLEANER
6. EXHAUST MANIFOLD & SILENCER
7. CAMSHAFT & DRIVING GEAR
8. CRANKSHAFT & PISTON
9. LUB.OIL SYSTEM
10. COOLING WATER SYSTEM
11. FUEL INJECTION PUMP
12. GOVERNOR
13. FUEL INJECTION VALVE
14. FUEL LINE
15. STARTING MOTOR
16. GENERATOR
17. GASKET SET & TOOLS

Fig. No. Fig. Name

Fig.1. CYLINDER BLOCK

(A)=3TNV76-HGB2B

(B)=

(C)=

(D)=

(E)=

(F)=

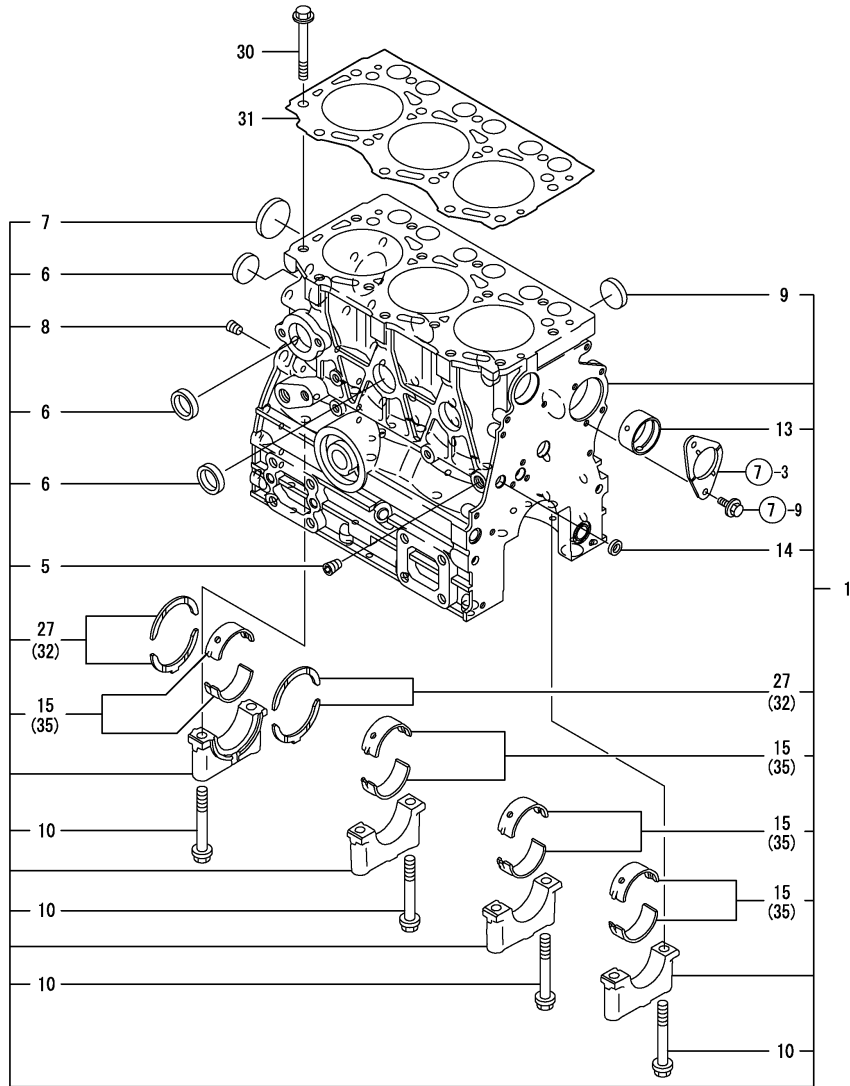

No.	Lev.	Parts No.	Description	Q'ty						I	R
				(A)	(B)	(C)	(D)	(E)	(F)		
1	1	719717-01561	BLOCK ASSY, CYLINDER	1							
5	2	124060-01050	PLUG, PT1/8	1							
6	2	105311-01090	PLUG, 30	4							
7	2	119623-01250	PLUG, 45	1							
8	2	124160-01910	PLUG, PT1/4	1							
9	2	119285-01990	PLUG, 25	3							
10	2	119620-02020	BOLT, METAL CAP	8							
13	2	119717-02411	BUSH, CAMSHAFT	1							
14	2	27241-120000	PLUG, 12	1							
15	2	719717-02901	BEARING, MAIN	4							2
27	2	119810-02931	BEARING, THRUST	1							
30	1	119810-01200	BOLT, HEAD	14							
31	1	119717-01330	GASKET, HEAD	1							
32	1	119810-02941	BEARING, THRUST 0.25	2							1
35	1	719717-02911	BEARING, 0.25 US	4							3

Remarks
 (1) OVER-SIZE(O.S=0.25)PART.
 (2) REPAIR PART.
 (3) UNDER-SIZE(U.S=0.25)PART

Fig.2. GEAR HOUSING

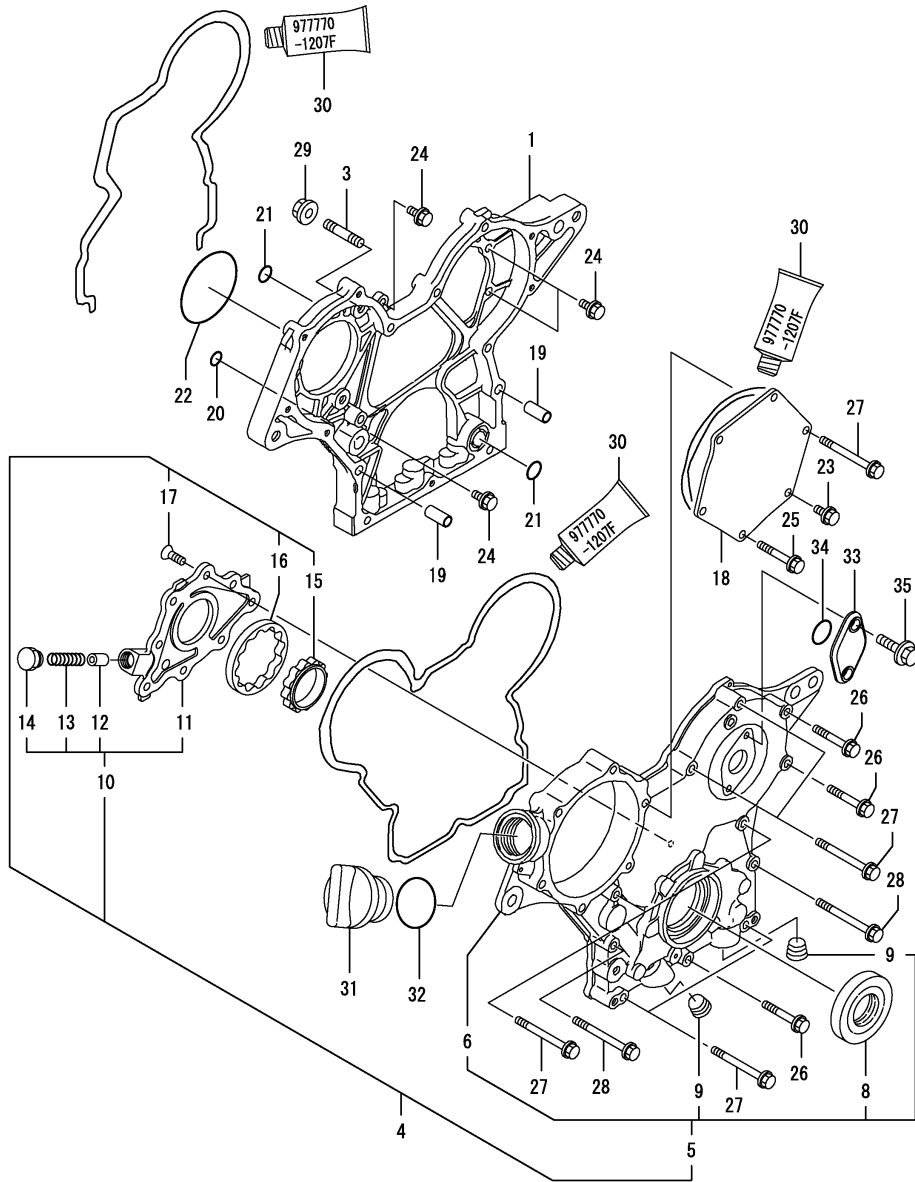

(A)=3TNV76-HGB2B

(B)=

(C)=

(D)=

(E)=

(F)=

No.	Lev.	Parts No.	Description	Q'ty						I	R
				(A)	(B)	(C)	(D)	(E)	(F)		
1	1	119717-01501	CASE, GEAR	1							
3	1	119717-01570	STUD	3							
4	1	119734-01580	CASE ASSY, GEAR	1							
5	2	719734-01510	CASE ASSY, GEAR	1							
6	3	119744-01521	COVER, GEAR CASE	1							
8	3	119717-01800	SEAL, OIL	1							
9	3	23876-030000	PLUG, R03	2							
10	2	119717-32100	COVER ASSY	1							
11	3	119717-32080	COVER	1							
12	3	129900-32130	VALVE, RELIEF	1							
13	3	129001-32320	SPRING	1							
14	3	129001-32330	PLUG	1							
15	2	119717-32110	ROTOR, INNER	1							
16	2	119717-32120	ROTOR, OUTER	1							
17	2	119802-32130	SCREW, M6X16	8							
18	1	119717-01750	COVER	1							
19	1	119660-01911	PIPE, KNOCK	4							
20	1	119624-32040	O-RING, P12.0	1							
21	1	119717-32050	O-RING, P17.0	3							
22	1	121850-51960	O-RING	1							
23	1	26106-060122	BOLT, M6X 12 PLATED	1							
24	1	26106-060162	BOLT, M6X 16 PLATED	4							
25	1	26106-060402	BOLT, M6X 40 PLATED	4							
26	1	26106-060402	BOLT, M6X 40 PLATED	3							
27	1	26106-060602	BOLT, M6X 60 PLATED	7							
28	1	26106-060652	BOLT, M6X 65 PLATED	2							
29	1	26306-080002	NUT, M8	3							
30	1	97770-1207F	GASKET.LIQUID	1							1
31	1	124160-01751	COVER, FILLER	1							
32	1	24311-000320	O-RING, 1AP32.0	1							
33	1	121023-01551	COVER	1							
34	1	24341-000240	O-RING, 1AS24.0	1							
35	1	26106-060162	BOLT, M6X 16 PLATED	2							

Remarks
(1) OPTIONAL PART.

Fig.3. FLYWHEEL HOUSING & OIL SUMP

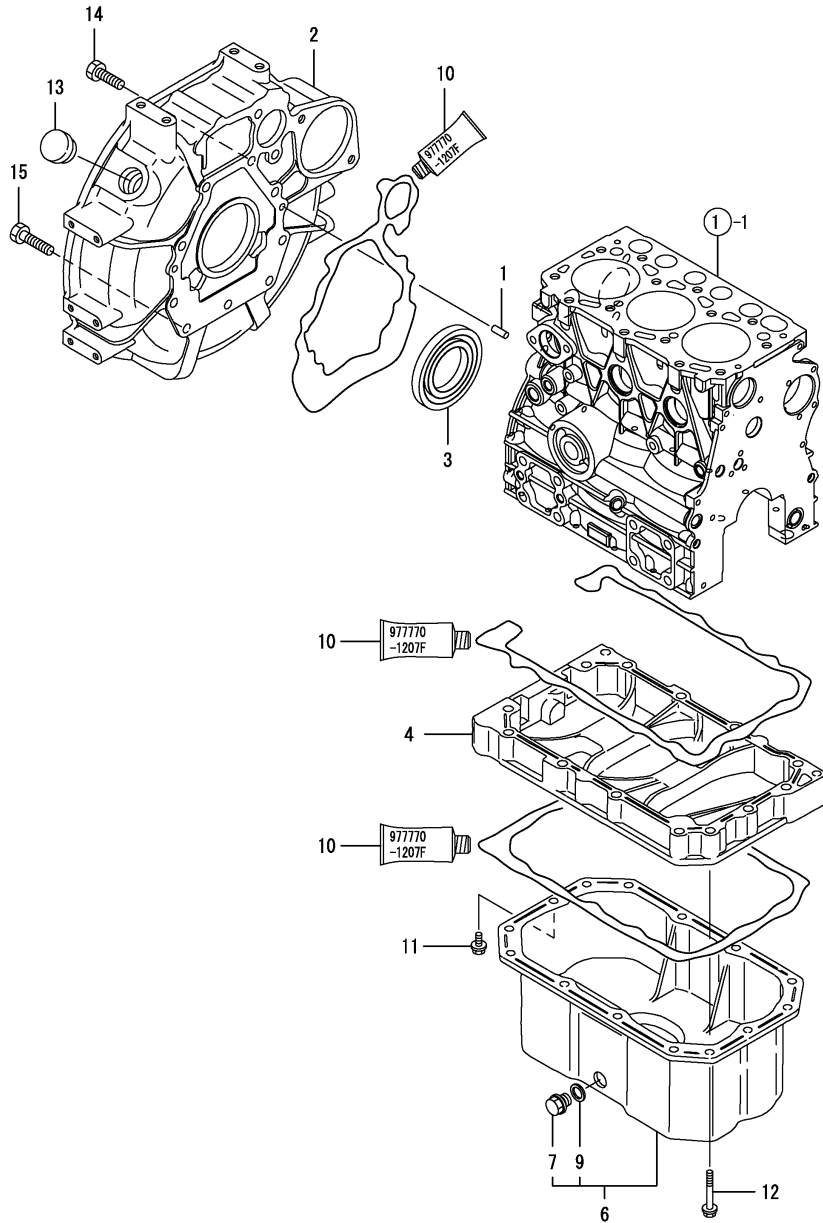

(A)=3TNV76-HGB2B

(B)=

(C)=

(D)=

(E)=

(F)=

No.	Lev.	Parts No.	Description	Q'ty						I	R
				(A)	(B)	(C)	(D)	(E)	(F)		
1	1	129100-01580	PIN, M8X16	2							
2	1	119717-01601	HOUSING, FLYWHEEL	1							
3	1	119734-02220	SEAL, OIL	1							
4	1	119717-01720	SPACER, OIL SUMP	1							
6	1	119746-01790	SUMP ASSY, OIL	1							
7	2	105425-01690	PLUG, 16	1							
9	2	22190-160002	WASHER, SEAL 16	1							
10	1	977770-1207F	GASKET.LIQUID	1							1
11	1	26106-080252	BOLT, M8X 25 PLATED	1							
12	1	26106-080602	BOLT, M8X 60 PLATED	13							
13	1	119620-01750	CAP	1							
14	1	26206-100252	BOLT, M10X 25 PLATED	8							
15	1	121120-01620	BOLT, M10X28	3							

Remarks
(1) OPTIONAL PART.

Fig.4. CYLINDER HEAD & BONNET

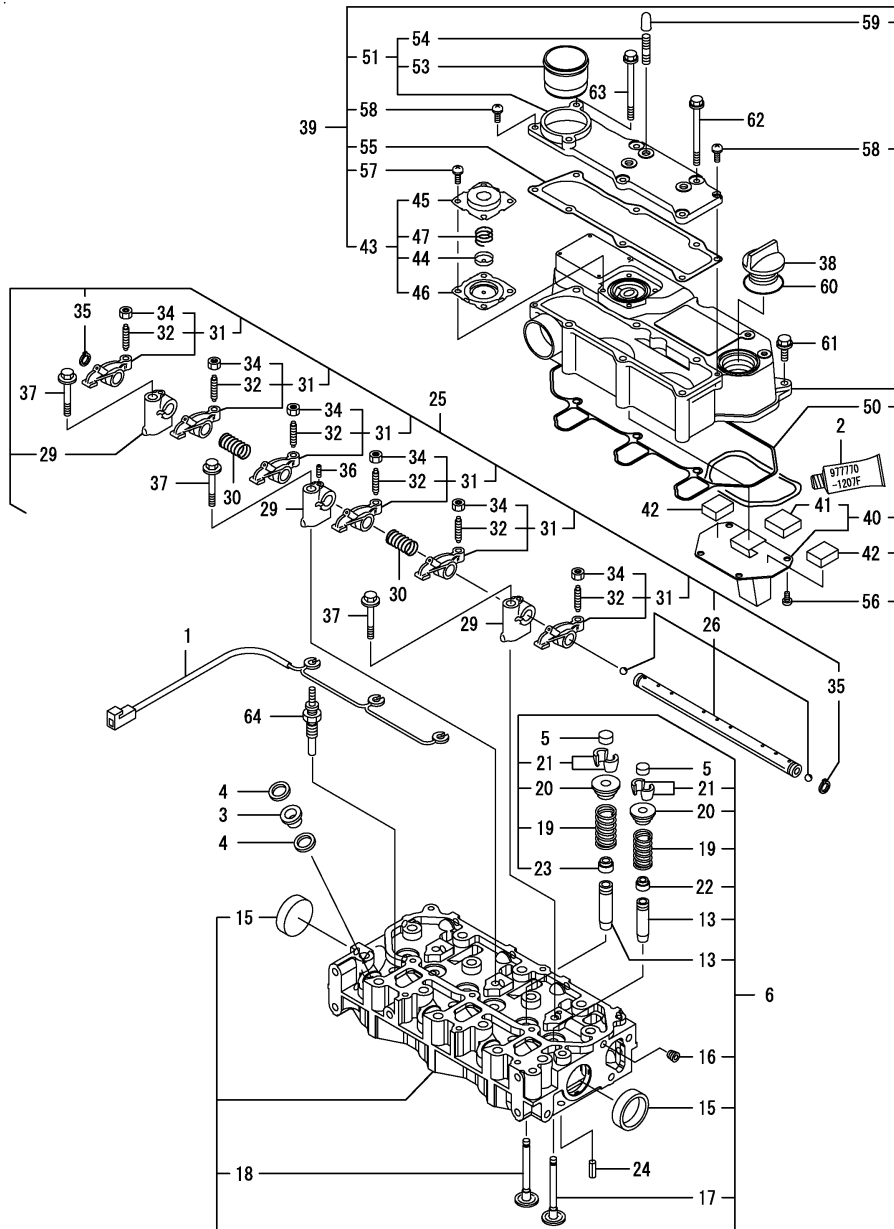

(A)=3TNV76-HGB2B

(B)=

(C)=

(D)=

(E)=

(F)=

No.	Lev.	Parts No.	Description	Q'ty						I	R
				(A)	(B)	(C)	(D)	(E)	(F)		
1	1	119717-77820	CONNECTOR, GLOW PLUG	1							
2	1	977770-1207F	GASKET, LIQUID	1							2
3	1	129901-11450	PROTECTOR, NOZZLE	3							
4	1	119600-11460	GASKET, NOZZLE	6							
5	1	105010-11490	CAP, VALVE	6							
6	1	119746-11740	HEAD ASSY, CYLINDER	1							
13	2	119717-11800	GUIDE, VALVE	6							1
15	2	119285-11990	PLUG, 35	2							
16	2	23876-005000	PLUG, R005	1							
17	2	119717-11101	VALVE, INTAKE	3							
18	2	119717-11110	VALVE, EXHAUST	3							
19	2	119717-11131	SPRING, VALVE	6							
20	2	129508-11180	RETAINER, SPRING	6							
21	2	119717-11190	COTTER	12							
22	2	119717-11340	SEAL, VALVE STEM	3							
23	2	119717-11350	SEAL, VALVE STEM	3							
24	1	22351-060012	PIN, SPRING 6.0X12	2							
25	1	119717-11200	SUPPORT ASSY, ARM	1							
26	2	119717-11240	SHAFT ASSY, ROCKER	1							
29	2	119717-11260	SUPPORT, ROCKER ARM	3							
30	2	119620-11280	SPRING	2							
31	2	119717-11650	ARM, ROCKER	6							
32	3	129150-11230	SCREW, VALVE ADJUST	6							
34	3	129150-11750	NUT, M8	6							
35	2	22242-000120	RING, 12	2							
36	2	26979-050162	SCREW, M5X16	1							
37	1	26106-080402	BOLT, M8X 40 PLATED	3							
38	1	124160-01751	COVER, FILLER	1							
39	1	119734-11380	BONNET ASSY, HEAD	1							
40	2	119717-03031	PLATE	1							
41	3	119717-03070	BAFFLE, BREATHER	1							
42	2	119717-03070	BAFFLE, BREATHER	2							
43	2	119802-03100	DIAPHRAGM ASSY	1							
44	3	119802-03110	PLATE	1							
45	3	119802-03121	COVER, DIAPHRAGM	1							
46	3	119802-03131	DIAPHRAGM	1							
47	3	119802-03141	SPRING, DIAPHRAGM	1							
50	2	119718-11310	GASKET, BONNET	1							
51	2	119734-11320	COVER ASSY, BONNET	1							
53	3	119734-11340	JOINT	1							
54	3	26216-080222	STUD, M8X 22	3							
55	2	119717-11331	GASKET	1							
56	2	22857-500100	SCREW, 5X10	4							
57	2	22857-500100	SCREW, 5X10	4							
58	2	22857-500160	SCREW, 5X16	2							
59	2	49933-000138	CAP	3							
60	1	24311-000320	O-RING, 1AP32.0	1							
61	1	26106-060202	BOLT, M6X 20 PLATED	3							
62	1	26106-060752	BOLT, M6X 75 PLATED	4							
63	1	26106-060852	BOLT, M6X 85 PLATED	2							
64	1	119717-77800	PLUG, GLOW	3							

Remarks
 (1) REPAIR PART.
 (2) OPTIONAL PART.

Fig.5. AIR CLEANER

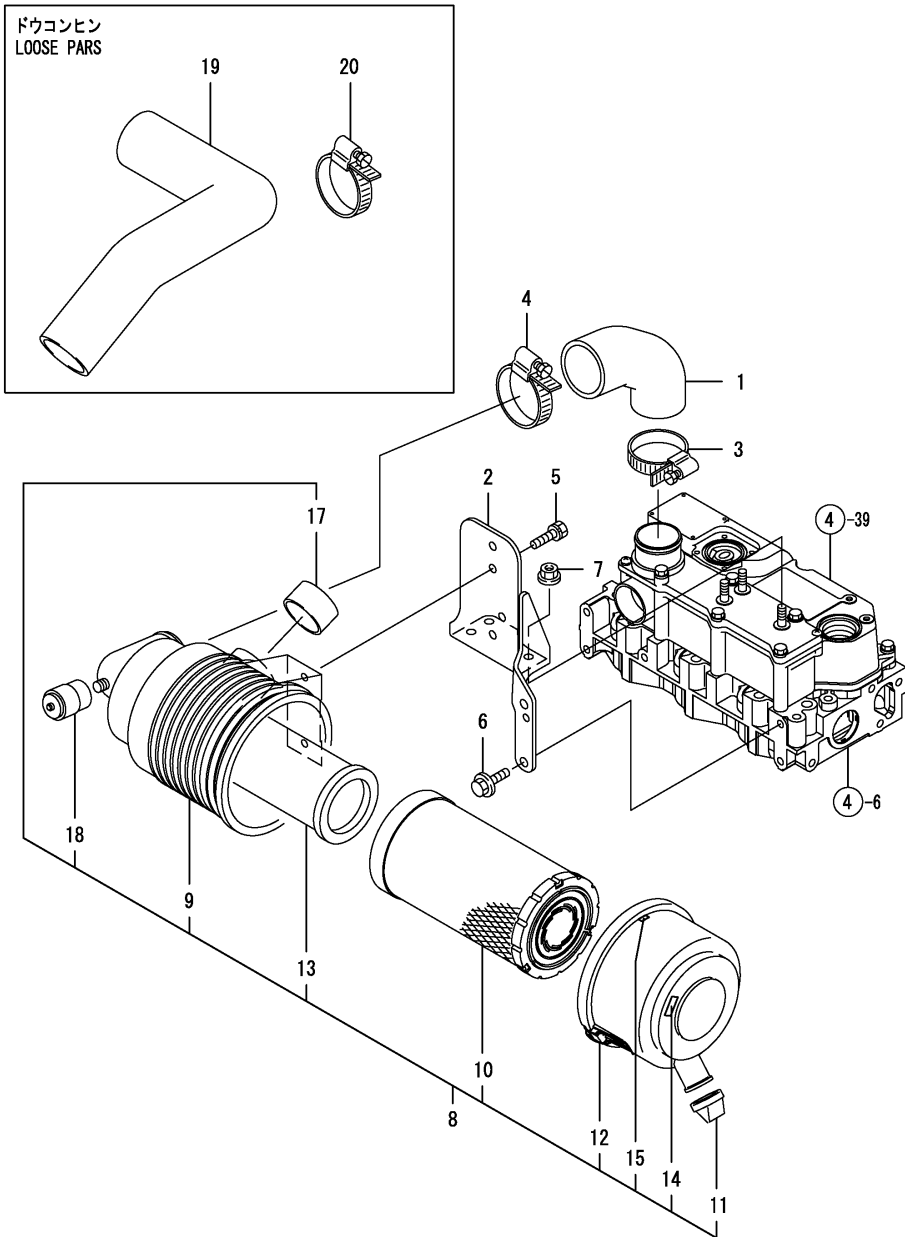

(A)=3TNV76-HGB2B

(B)=

(C)=

(D)=

(E)=

(F)=

No.	Lev.	Parts No.	Description	Qty						I	R
				(A)	(B)	(C)	(D)	(E)	(F)		
1	1	119734-12200	PIPE, AIR INTAKE	1							
2	1	119734-12601	SUPPORT, AIR CLEANER	1							
3	1	23000-054000	CLAMP, 54	1							
4	1	23000-060000	CLAMP, 60	1							
5	1	26013-080222	BOLT, M8X 22	2							
6	1	26106-080162	BOLT, M8X 16 PLATED	1							
7	1	26306-080002	NUT, M8	3							
8	1	119746-12500	CLEANER ASSY, AIR	1							
9	2	119734-12510	BODY, AIR CLEANER	1							
10	2	129004-12520	ELEMENT 5INCH	1							
11	2	119808-12540	VALVE, UNLOADER	1							
12	2	119866-12541	COVER ASSY	1							
13	2	129051-12530	ELEMENT	1							
14	2	129612-12650	MARKING,(W)	1							
15	2	129418-12530	MARK	2							
17	2	129259-12570	RING	1							
18	2	126650-12680	INDICATOR	1							
19	1	119746-12560	PIPE, AIR INTAKE	1							
20	1	23000-060000	CLAMP, 60	1							

Fig.6. EXHAUST MANIFOLD & SILENCER

(A)=3TNV76-HGB2B

(B)=

(C)=

(D)=

(E)=

(F)=

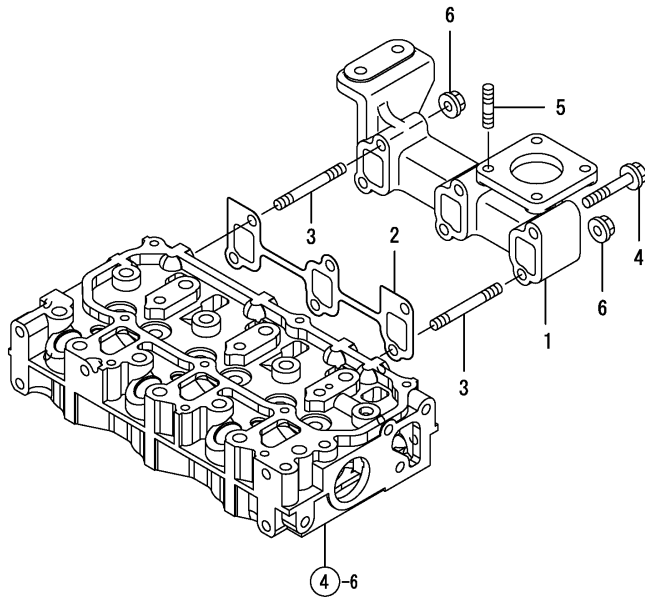
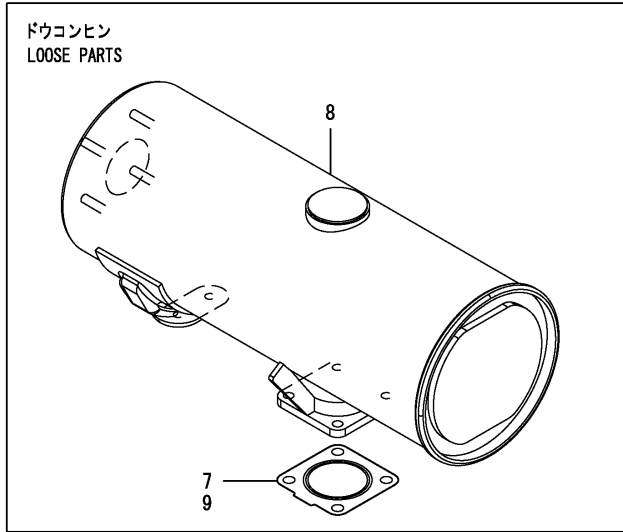

No.	Lev.	Parts No.	Description	Q'ty						I	R
				(A)	(B)	(C)	(D)	(E)	(F)		
1	1	119717-13109	MANIFOLD, EXHAUST	1							
2	1	119717-13110	GASKET	1							
3	1	119717-13600	STUD, M8X50	2							
4	1	119802-13620	BOLT, M8X50	4							
5	1	119131-18320	STUD, M8X22	4							
6	1	26306-080002	NUT, M8	2							
7	1	119515-13200	GASKET, SILENCER	1							
8	1	129601-13500	SILENCER	1							
9	1	129930-13201	GASKET, SILENCER	4							

Fig.7. CAMSHAFT & DRIVING GEAR

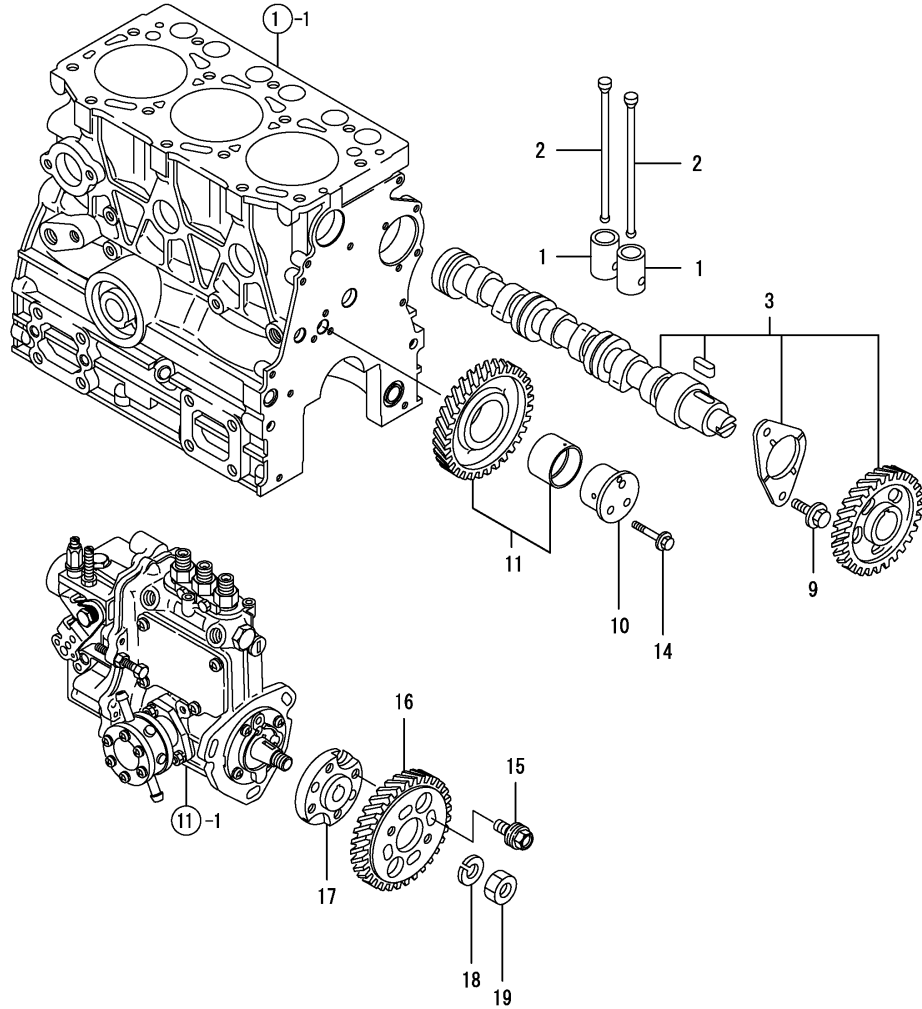

(A)=3TNV76-HGB2B

(B)=

(C)=

(D)=

(E)=

(F)=

No.	Lev.	Parts No.	Description	Q'ty						I	R
				(A)	(B)	(C)	(D)	(E)	(F)		
1	1	119620-14200	TAPPET	6							
2	1	119717-14400	ROD, PUSH	6							
3	1	119717-14581	CAMSHAFT ASSY	1							
9	1	26106-060122	BOLT, M6X 12 PLATED	2							
10	1	119717-25050	SHAFT, IDLE	1							
11	1	119717-25101	GEAR ASSY, IDLE	1							
14	1	26106-060352	BOLT, M6X 35 PLATED	3							
15	1	129150-25301	BOLT	4							
16	1	119717-25930	GEAR, PUMP	1							
17	1	119717-51150	FLANGE	1							
18	1	22217-120000	WASHER, SPRING 12	1							
19	1	26716-120002	NUT, M12	1							

Fig.8. CRANKSHAFT & PISTON

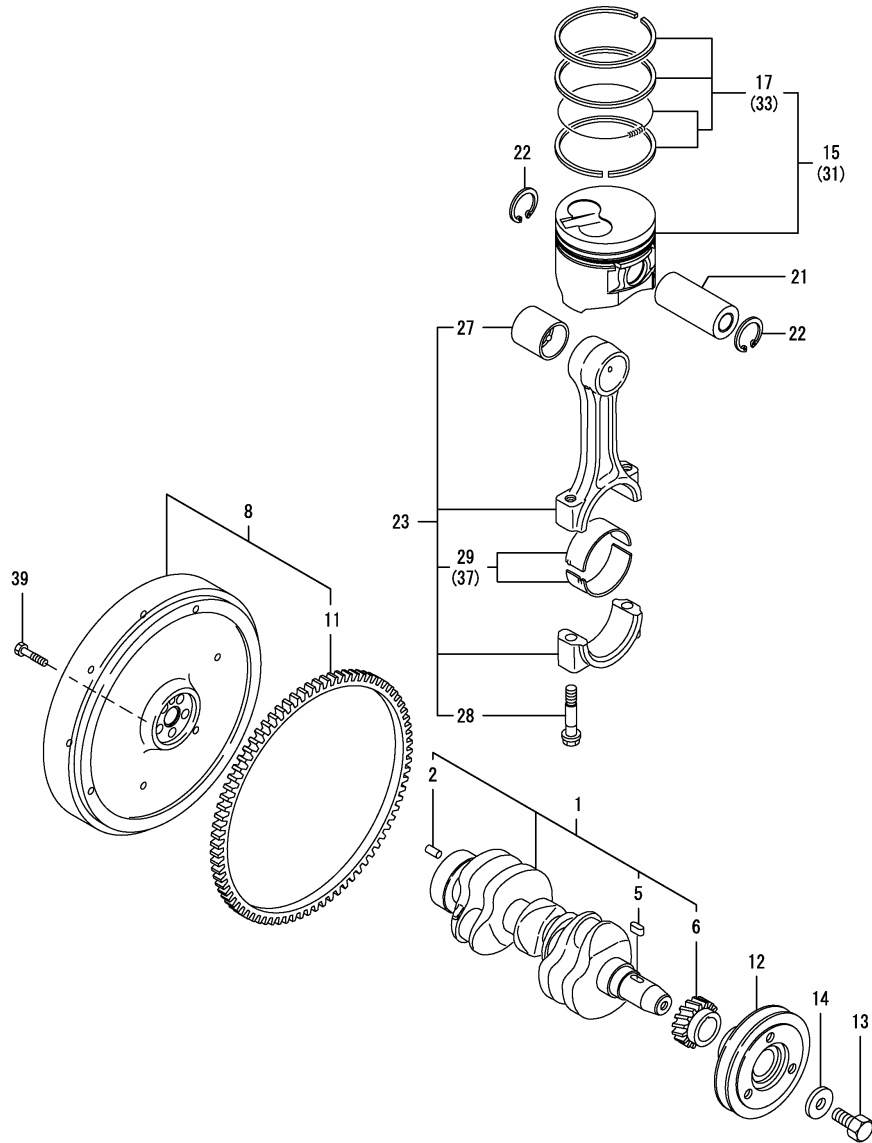

(A)=3TNV76-HGB2B

(B)=

(C)=

(D)=

(E)=

(F)=

No.	Lev.	Parts No.	Description	Q'ty						I	R
				(A)	(B)	(C)	(D)	(E)	(F)		
1	1	119717-21700	CRANKSHAFT ASSY	1							
2	2	129100-01580	PIN, M8X16	1							
5	2	22512-040120	KEY, 4X 12	1							
6	2	119717-21200	GEAR, CRANKSHAFT	1							
8	1	119636-21590	FLYWHEEL ASSY	1							
11	2	119865-21600	GEAR, RING	1							
12	1	119717-21650	V-PULLEY	1							
13	1	119621-21680	BOLT, FLANGE 12X1.25	1							
14	1	119620-21941	WASHER	1							
15	1	119717-22080	PISTON ASSY	3							
17	2	119717-22500	RING SET, PISTON	3							
21	1	119717-22300	PIN, PISTON	3							
22	1	22252-000220	RING, 22	6							
23	1	119717-23000	ROD ASSY, CONNECTING	3							
27	2	119717-23910	BEARING, PISTON PIN	3							2
28	2	119717-23200	BOLT, CONNECTING ROD	6							
29	2	119717-23601	BEARING, CRANK PIN	3							
31	1	119717-22090	PISTON ASSY, 0.25 OS	3							1
33	2	119717-22550	RING SET, 0.25 OS	3							1
37	1	119717-23611	METAL ASSY, 0.25	3							3
39	1	121111-21501	BOLT, FLYWHEEL	5							

Remarks

- (1) OVER-SIZE(O.S=0.25)PART.
- (2) REPAIR PART.
- (3) UNDER-SIZE(U.S=0.25)PART.

Fig.9. LUB.OIL SYSTEM

(A)=3TNV76-HGB2B

(B)=

(C)=

(D)=

(E)=

(F)=

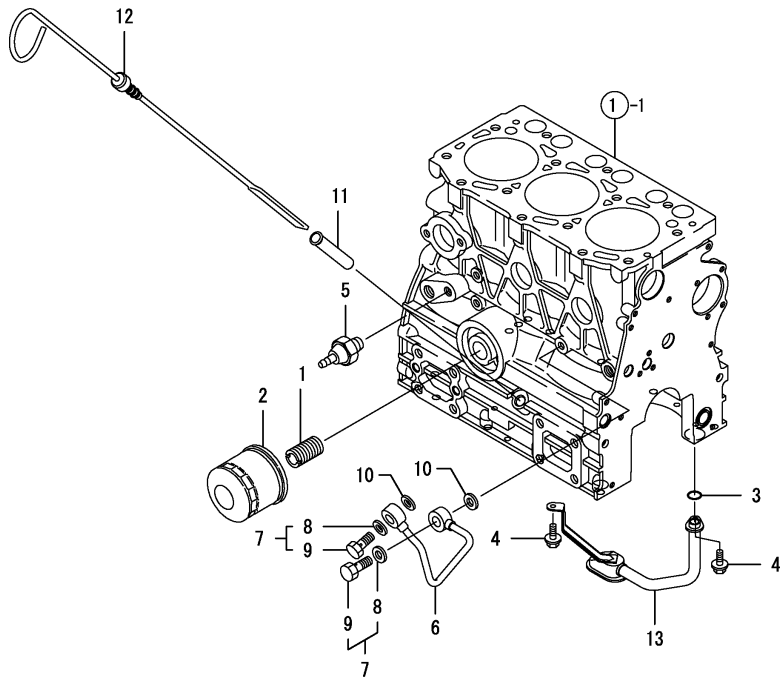

No.	Lev.	Parts No.	Description	Q'ty						I	R
				(A)	(B)	(C)	(D)	(E)	(F)		
1	1	129100-35140	STUD	1							
2	1	119305-35151	FILTER ASSY, D68XL65	1							1
3	1	119717-32060	O-RING, P15.0	1							
4	1	26106-060102	BOLT, M6X 10 PLATED	2							
5	1	114250-39450	SWITCH, 0.5KG	1							
6	1	119717-39210	PIPE, OIL	1							
7	1	129005-59830	BOLT ASSY, JOINT M8	2							
8	2	22190-080002	WASHER, SEAL 6	2							
9	2	23857-030000	BOLT, JOINT 3	2							
10	1	22190-080002	WASHER, SEAL 6	2							
11	1	121520-34810	GUIDE, DIPSTICK	1							
12	1	119746-34801	DIPSTICK, OIL	1							
13	1	119744-35080	PIPE ASSY, OIL INLET	1							

Remarks
(1) REPAIR PART.

Fig.10. COOLING WATER SYSTEM

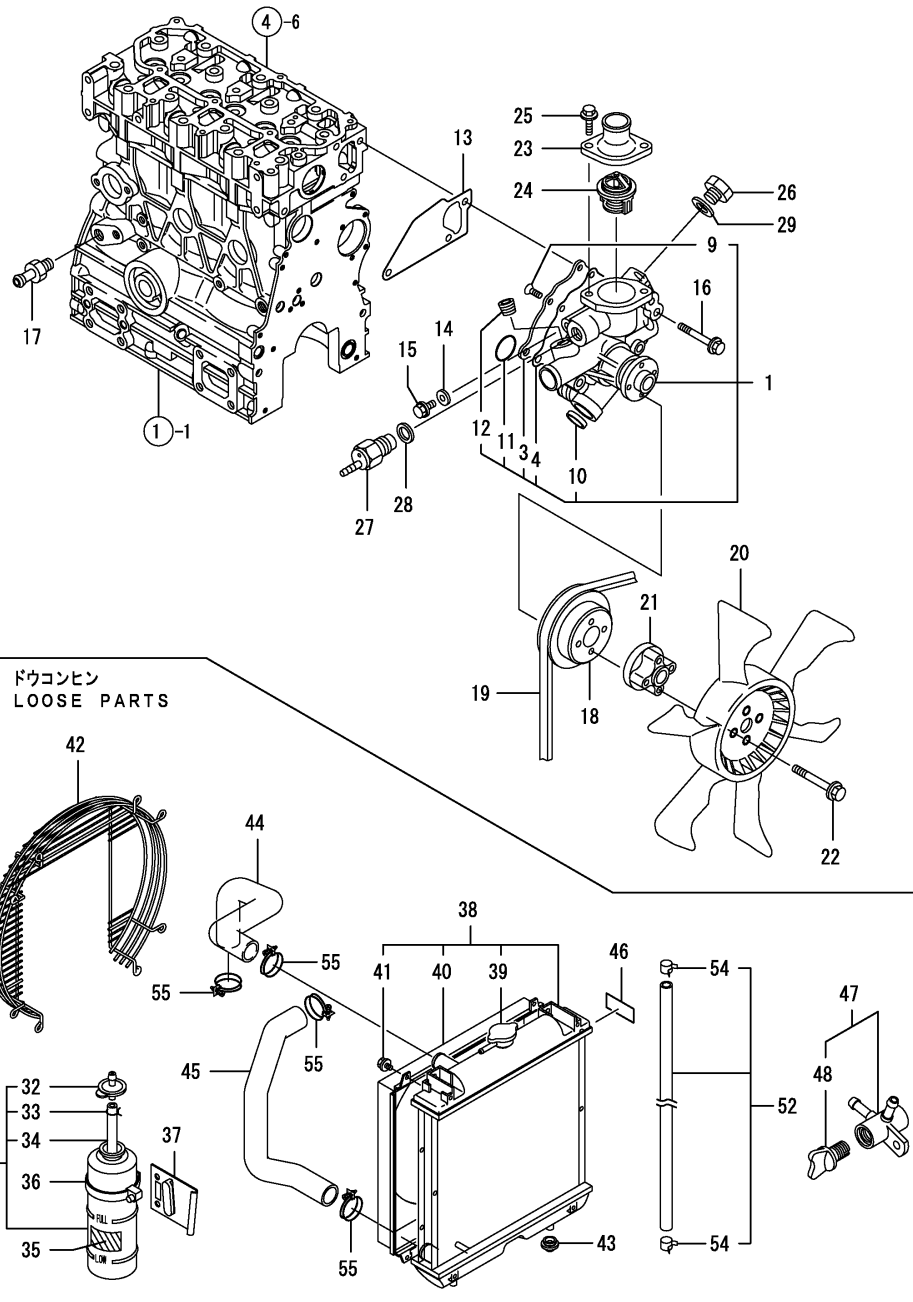

(A)=3TNV76-HGB2B

(B)=

(C)=

(D)=

(E)=

(F)=

No.	Lev.	Parts No.	Description	Q'ty						I	R
				(A)	(B)	(C)	(D)	(E)	(F)		
1	1	119717-42002	PUMP ASSY, WATER	1							
1-1	1	119E10-42000	PUMP ASSY, WATER	1							N
(A=E/ B6264)											
3	2	119717-42041	COVER	1							
4	2	119717-42031	GASKET	1							
9	2	26577-060122	SCREW, M6X12	4							
10	2	27241-250000	PLUG, 25	1							
11	2	119717-42320	O-RING, P26	1							
11-1	2	119C10-42320	O-RING, 2028	1							S
(A=E/ B6264)											
12	2	129916-49740	PLUG, R03	1							
13	1	119717-42020	GASKET, WATER PUMP	1							
14	1	23414-080000	GASKET, 8X1.0	1							
15	1	26106-080122	BOLT, M8X 12 PLATED	1							
16	1	26106-080502	BOLT, M8X 50 PLATED	3							
17	1	121550-49111	JOINT, PT1/4	1							
18	1	119515-42350	V-PULLEY, D=110	1							
19	1	129612-42310	V-BELT, A36.5	1							
20	1	171340-44740	FAN, COOLING D335XNF	1							
21	1	129457-44760	SPACER, FAN	1							
22	1	26106-060452	BOLT, M6X 45 PLATED	4							
23	1	129350-49530	COVER, THERMOSTAT	1							
24	1	119717-49800	THERMOSTAT, 71	1							
25	1	26106-080202	BOLT, M8X 20 PLATED	2							
26	1	121450-42450	PLUG, M16	1							
27	1	121250-44901	SWITCH, 110	1							
28	1	124465-44950	GASKET, 16	1							
29	1	124465-44950	GASKET, 16	1							
30	1	124450-44510	TANK ASSY, SUB	1							
32	2	124450-44530	CAP	1							
33	2	124450-44560	RETAINER	1							
34	2	23061-070230	PIPE, 7X 230	1							
35	1	124764-44810	LABEL, SUB TANK	1							
36	1	124450-44550	BAND	1							
37	1	121256-44600	BRACKET, SUB TANK	1							
38	1	129004-44500	RADIATOR ASSY	1							
39	2	129107-44590	CAP, RADIATOR	1							
40	2	119802-44600	SHROUD	1							
41	2	26014-060122	BOLT, M6X 12	4							
42	1	119802-44560	GUARD	1							
43	1	119255-44660	ABSORBER	2							
44	1	119734-49010	PIPE, WATER	1							
45	1	119740-49060	PIPE, WATER	1							
46	1	121400-44910	LABEL, RADIATOR	1							
47	1	129150-49100	COCK ASSY, 3-WAY	1							
48	2	129150-49080	COCK, DRAIN	1							
52	1	129210-49280	PIPE ASSY, DRAIN	1							
54	2	124766-59050	CLIP, HOSE 12	2							
55	1	23010-038000	CLAMP, 38	4							

Fig.11. FUEL INJECTION PUMP

(A)=3TNV76-HGB2B

(B)=

(C)=

(D)=

(E)=

(F)=

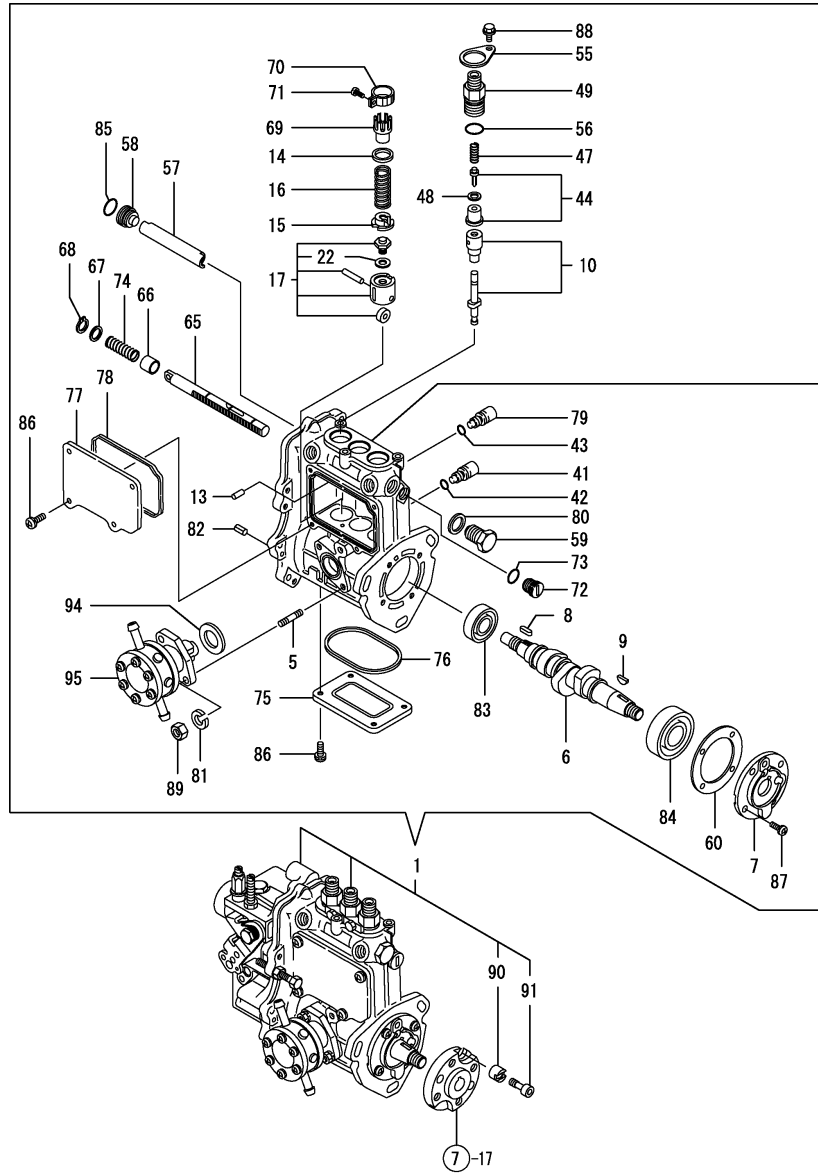

No.	Lev.	Parts No.	Description	Q'ty						I	R
				(A)	(B)	(C)	(D)	(E)	(F)		
1	1	719746-51320	PUMP ASSY, INJECTION	1							
5	2	129155-51020	STUD	2							
6	2	119717-51030	CAMSHAFT	1							
7	2	119717-51060	SUPPORT, CAMSHAFT	1							
8	2	119717-51070	KEY	1							
9	2	122710-51090	KEY	1							
10	2	119717-51100	PLUNGER ASSY	3							
13	2	129155-51140	PIN	3							
14	2	158600-51170	RETAINER, SPRING	3							
15	2	119717-51570	RETAINER, SPRING	3							
16	2	119717-51190	SPRING, PLUNGER	3							
17	2	119717-51200	TAPPET ASSY	3							
22	3	129155-51600	SHIM SET, ADJUSTING	1							
41	2	158600-51270	STOPPER, TAPPET	3							
42	2	129155-51280	O-RING, S6	3							
43	2	129155-51280	O-RING, S6	1							
44	2	119717-51300	VALVE ASSY, DELIVERY	3							
47	2	119717-51330	SPRING, DELIVERY	3							
48	2	124550-51350	GASKET, DELIVERY	3							
49	2	158600-51442	VALVE ASSY, DELIVERY	3							
55	2	118400-51370	LOCKING	3							
56	2	24316-000150	O-RING, 4DP15.0	3							
57	2	129155-51400	DEFLECTOR	1							
58	2	158600-51410	PLUG, DEFLECTOR	1							
59	2	158600-51420	PLUG, DEFLECTOR	1							
60	2	129155-51450	SHIM SET, ADJUSTING	1							
65	2	119717-51500	RACK, CONTROL	1							
66	2	129155-51521	BUSH, RACK	1							
67	2	129155-51530	SPACER	1							
68	2	129155-51540	CIRCLIP	1							
69	2	129155-51550	PINION, CONTROL	3							
70	2	129100-51560	PINION	3							
71	2	129100-51570	SCREW	3							
72	2	158600-51570	PLUG	1							
73	2	129155-51580	O-RING	1							
74	2	129155-51591	SPRING, RACK	1							
75	2	129155-51701	COVER	1							
76	2	119717-51711	GASKET	1							
77	2	119717-51750	COVER	1							
78	2	119717-51761	GASKET	1							
79	2	158600-51790	STOOPER, RACK	1							
80	2	22190-160002	WASHER, SEAL 16	1							
81	2	22217-060000	WASHER, SPRING 6	2							
82	2	22351-050010	PIN, SPRING 5.0X10	2							
83	2	24101-060034	BEARING, BALL 6003	1							
84	2	24101-063034	BEARING, BALL 6303	1							
85	2	119717-51420	O-RING	1							
86	2	26022-050122	SCREW, M5X12	8							
87	2	26022-060162	SCREW, M6X16	4							
88	2	26106-050102	BOLT, M5X 10 PLATED	3							
89	2	26716-060002	NUT, M6	2							

Remarks
 (1) GOVERNOR ASSY(FIG.12) IS
 INCORPORATED IN THIS FOP.CMP
 (REF.NO.1).

Fig.11. FUEL INJECTION PUMP

(A)=3TNV76-HGB2B

(B)=

(C)=

(D)=

(E)=

(F)=

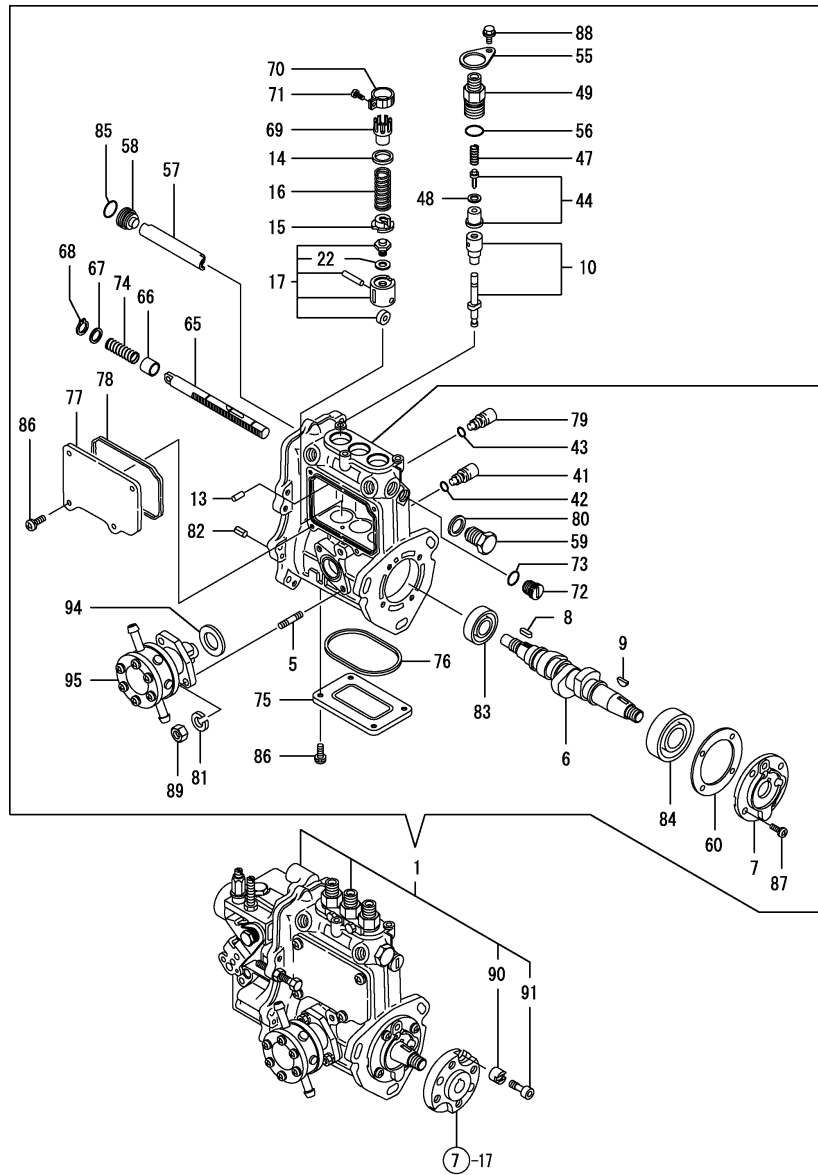

No.	Lev.	Parts No.	Description	Q'ty						I	R
				(A)	(B)	(C)	(D)	(E)	(F)		
90	2	119717-51480	COLLAR	1							
91	2	119717-51490	BOLT	1							
94	2	129155-52051	GASKET	1							
95	2	129100-52101	PUMP ASSY, FUEL FEED	1							

Remarks
 (1) GOVERNOR ASSY(FIG.12) IS
 INCORPORATED IN THIS FOP.CMP
 (REF.NO.1).

Fig.12. GOVERNOR

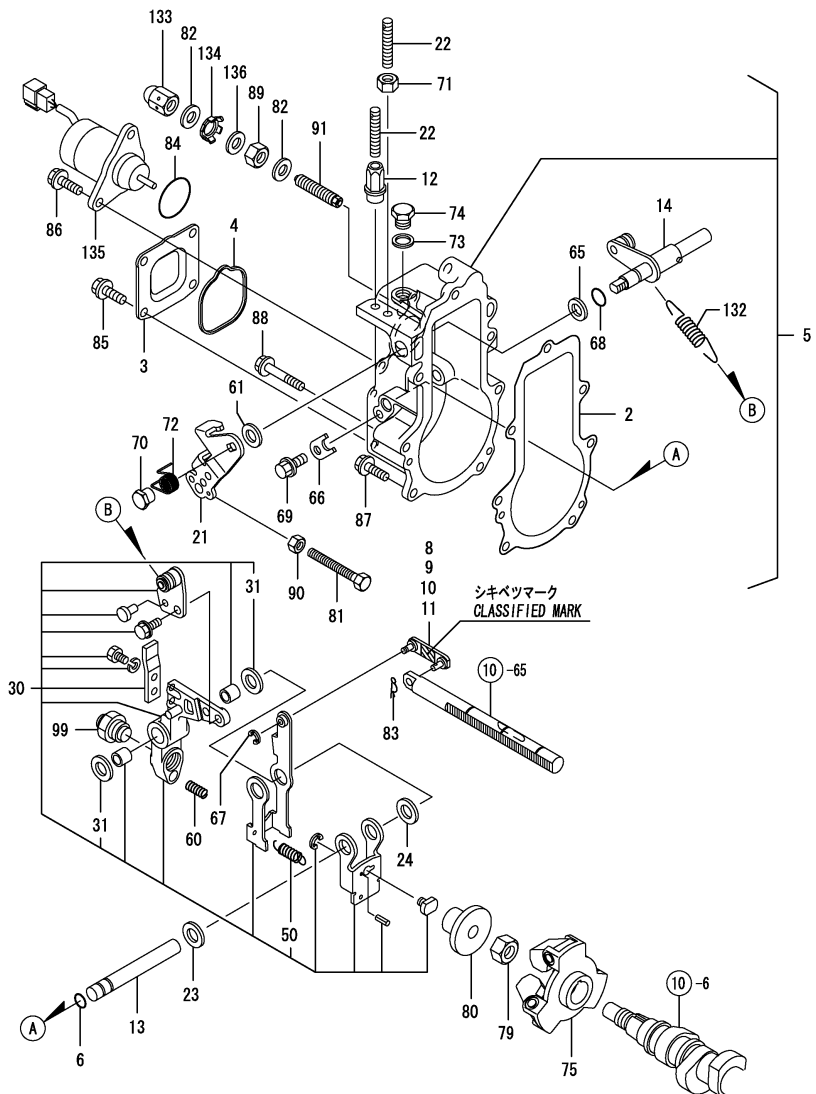

(A)=3TNV76-HGB2B
(B)=
(C)=

(D)=
(E)=
(F)=

No.	Lev.	Parts No.	Description	Q'ty						I	R
				(A)	(B)	(C)	(D)	(E)	(F)		
2	2	119717-61050	GASKET	1							
3	2	119717-61060	COVER, GOVERNOR CASE	1							
4	2	119717-61070	GASKET	1							
5	2	119746-61200	CASE ASSY, GOVERNOR	1							
6	3	129155-51280	O-RING, S6	1							
8	3	119717-61120	LINK, MARK :3	1							1
9	3	119717-61130	LINK, MARK 98	1							1
10	3	119717-61140	LINK, MARK 88	1							1
11	3	119717-61150	LINK, MARK 03	1							1
12	3	129209-61370	NUT, M6	1							
13	3	129052-61390	SHAFT	1							
14	3	119717-61400	SHAFT ASSY	1							
21	3	119415-61440	LEVER, CONTROL	1							
22	3	129155-61450	BOLT, LIMITER	2							
23	3	129156-61460	SHIM, T=0.6	1							
24	3	129155-61480	SPACER ASSY	1							
30	3	119717-61500	LEVER ASSY, GOVERNOR	1							
31	4	174307-51700	SHIM SET	2							
50	4	129486-61540	SPRING, SET	1							
60	3	129100-61650	SPRING, CONTROLLER	1							
61	3	158552-61700	SHIM SET	1							
65	3	158552-61710	SHIM, T=1.0	1							
66	3	119660-61901	RETAINER, SHAFT	1							
67	3	22272-000030	RING, E- 3	1							
68	3	24341-000070	O-RING, 1AS7.0	1							
69	3	26106-060102	BOLT, M6X 10 PLATED	1							
70	3	129255-61410	NUT, LOCK	1							
71	3	26756-060002	NUT, LOCK M6	1							
72	3	119527-61420	SPRING	1							
73	2	22190-100002	WASHER, SEAL 10	1							
74	2	23887-100002	PLUG, 10	1							
75	2	119717-61200	WEIGHT ASSY,GOVERNOR	1							
79	2	119660-61300	NUT	1							
80	2	129155-61341	SLEEVE	1							
81	2	129155-61460	BOLT, IDLE	1							
82	2	22190-120002	WASHER, SEAL 12	2							
83	2	22372-040000	PIN, SNAP 4	1							
84	2	158552-61900	O-RING	1							
85	2	26106-060102	BOLT, M6X 10 PLATED	1							
86	2	26106-060142	BOLT, M6X 14 PLATED	2							
87	2	26106-060202	BOLT, M6X 20 PLATED	4							
88	2	26106-060452	BOLT, M6X 45 PLATED	3							
89	2	26736-120002	NUT, M12	1							
90	2	26756-060002	NUT, LOCK M6	1							
91	2	158601-61700	LIMITER ASSY, FUEL	1							
99	2	119761-61560	ANGLEICH ASSY	1							
132	2	129573-61700	SPRING, GOVERNOR	1							
133	2	129209-61930	NUT, CAP	1							
134	2	129209-61970	PLATE	1							
135	2	119653-77950	SOLENOID, STOP	1							
136	2	23414-120016	GASKET, 12X1.0	1							

Remarks
(1) SELECTIVE PARTS: CERTAIN THE CLASSIFICATION MARK, THEN PLACE YOUR ORDER.(REF. TO ILLUSTRATION)
* THIS FIGURE(GOVERNOR ASSY)IS INCORPORATED IN THE FUEL INJECTION PUMP ASSY(FIG.11).

Fig.13. FUEL INJECTION VALVE

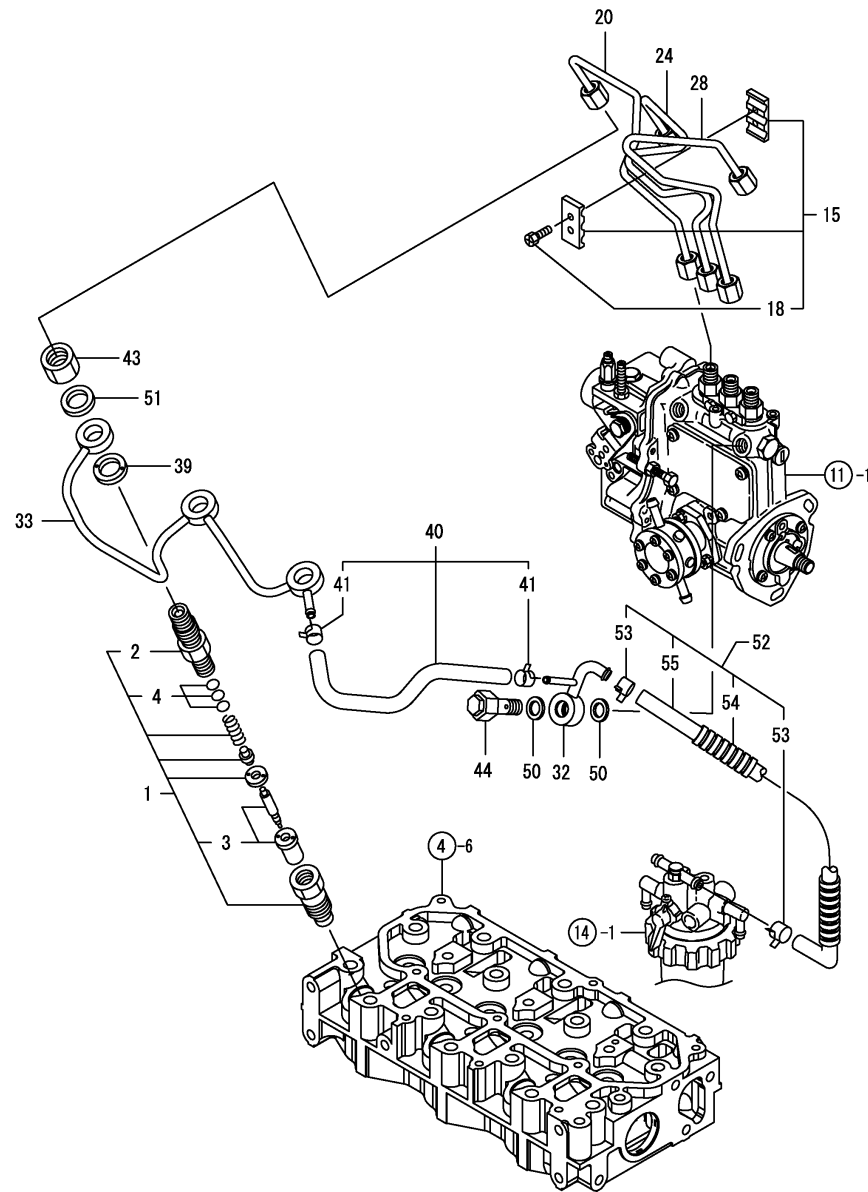

(A)=3TNV76-HGB2B

(B)=

(C)=

(D)=

(E)=

(F)=

No.	Lev.	Parts No.	Description	Q'ty						I	R
				(A)	(B)	(C)	(D)	(E)	(F)		
1	1	119515-53001	VALVE ASSY,INJECTION	3							
2	2	118200-53010	HOLDER, NOZZLE	3							
3	2	119515-53010	VALVE ASSY,INJECTION	3							
4	2	129901-53800	SHIM SET, ADJUSTING	3							1
15	1	129150-59120	RETAINER, PIPE	1							
18	2	129150-59131	BOLT, M4X14	2							
20	1	119746-59810	PIPE ASSY, INJECTION	1							
24	1	119746-59820	PIPE ASSY, INJECTION	1							
28	1	119746-59830	PIPE ASSY, INJECTION	1							
32	1	119515-59581	JOINT, OVER FLOW	1							
33	1	119717-59510	PIPE ASSY, RETURN	1							
39	1	129901-59560	GASKET	3							
40	1	119744-59560	PIPE ASSY, RETURN	1							
41	2	124066-59100	CLIP, HOSE 8	2							
43	1	119620-59700	NUT, NOZZLE	3							
44	1	119813-59950	VALVE ASSY, CHECK	1							
50	1	22190-120002	WASHER, SEAL 12	2							
51	1	22190-120002	WASHER, SEAL 12	3							
52	1	129457-59010	PIPE ASSY, FUEL	1							
53	2	124766-59050	CLIP, HOSE 12	2							
54	2	129957-59120	TUBE, CORRUGATED	1							
55	2	105025-59750	PIPE, FUEL	1							

Remarks
(1) REPAIR PART.

Fig.14. FUEL LINE

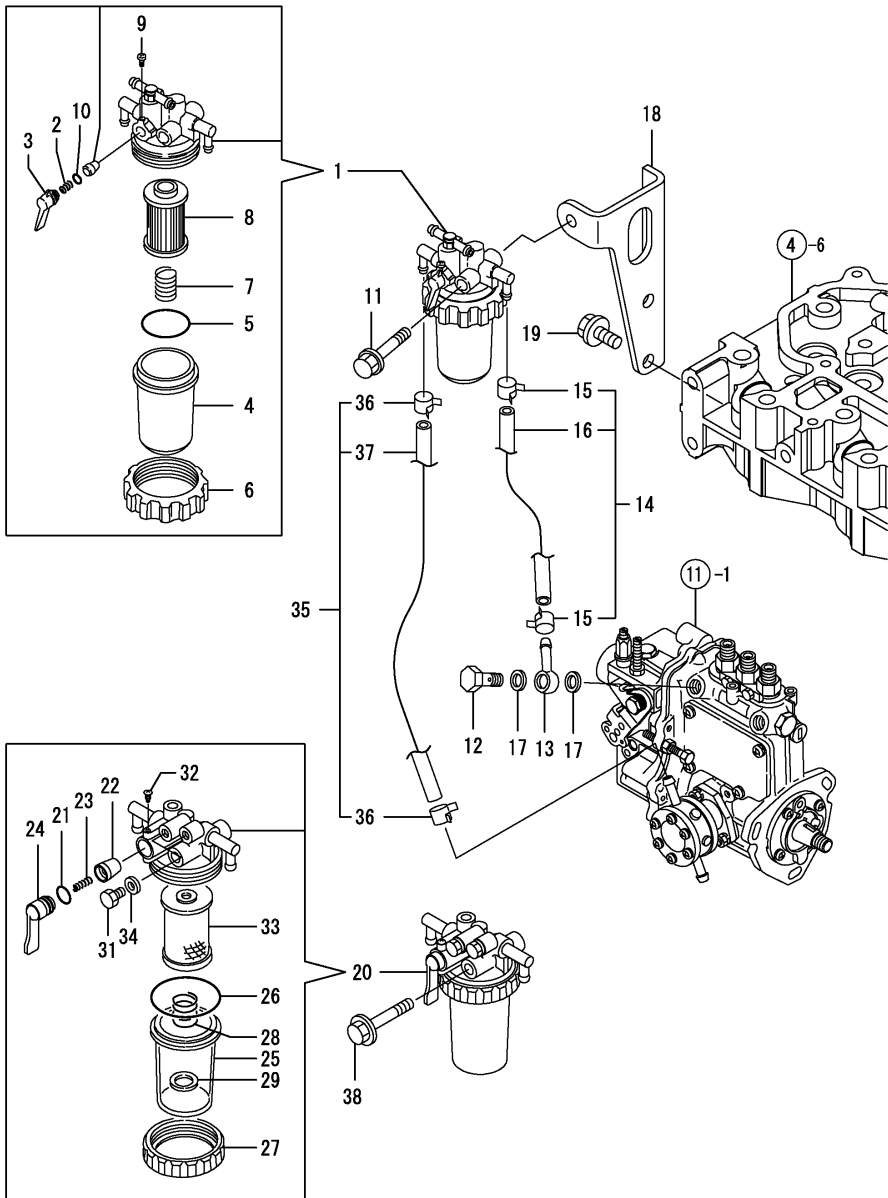

(A)=3TNV76-HGB2B

(B)=

(C)=

(D)=

(E)=

(F)=

No.	Lev.	Parts No.	Description	Qty						I	R
				(A)	(B)	(C)	(D)	(E)	(F)		
1	1	119833-55620	FILTER ASSY, FUEL	1							
2	2	104200-55330	SPRING, VALVE	1							
3	2	119810-55340	LEVER	1							
4	2	121254-55510	COVER	1							
5	2	102103-55520	O-RING	1							
6	2	110250-55610	RING, RETAINING	1							
7	2	121250-55620	SPRING	1							
8	2	119810-55650	ELEMENT	1							
9	2	104200-55750	SCREW, M4	1							
10	2	24311-240100	O-RING, 1AP10A	1							
11	1	26014-080702	BOLT, M8X 70	1							
12	1	103854-39140	BOLT, PIPE JOINT	1							
13	1	101304-59020	JOINT, PIPE 12	1							
14	1	129210-59080	PIPE ASSY, FUEL	1							
15	2	124766-59050	CLIP, HOSE 12	2							
16	2	129136-59110	PIPE, D13/7.5X270	1							
17	1	22190-120002	WASHER, SEAL 12	2							
18	1	119717-55650	BRACKET, FILTER	1							
19	1	26106-080162	BOLT, M8X 16 PLATED	2							
20	1	129335-55700	SEPARATOR ASSY,WATER	1							
21	2	24311-240100	O-RING, 1AP10A	1							
22	2	104200-55321	VALVE, TAPER	1							
23	2	104200-55330	SPRING, VALVE	1							
24	2	104200-55341	HANDLE	1							
25	2	124064-55510	COVER	1							
26	2	102103-55520	O-RING	1							
27	2	110250-55610	RING, RETAINING	1							
28	2	121257-55720	SPRING	1							
29	2	121257-55731	FLOAT	1							
31	2	101720-55750	PLUG, 6	2							
32	2	104200-55750	SCREW, M4	1							
33	2	171081-55910	SCREEN	1							
34	2	23418-060000	GASKET, 6X1.0	2							
35	1	129210-59170	PIPE ASSY, FUEL	1							
36	2	124766-59050	CLIP, HOSE 12	2							
37	2	105225-59511	PIPE, FUEL	1							
38	1	26014-080702	BOLT, M8X 70	1							

Fig.15. STARTING MOTOR

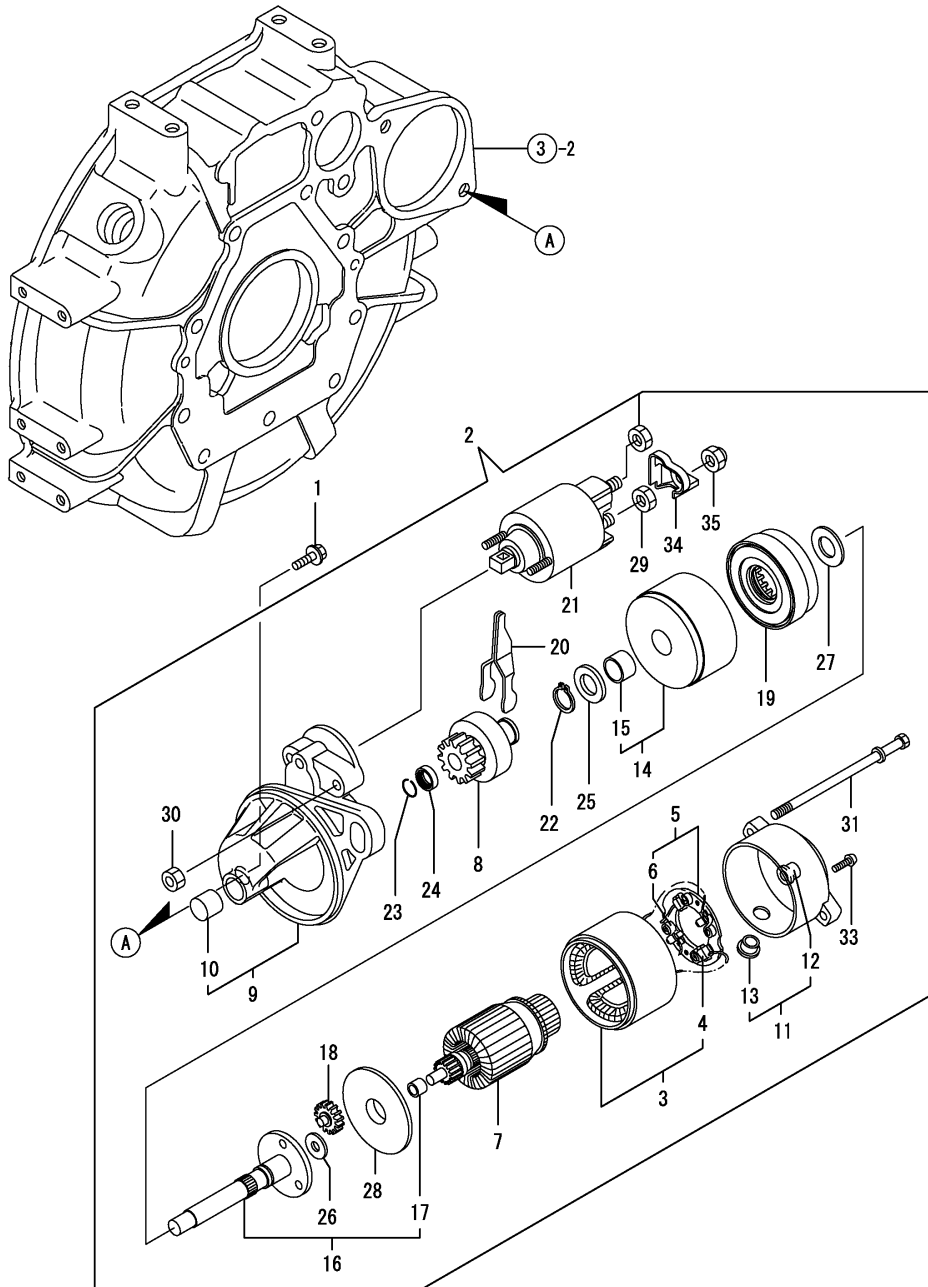

(A)=3TNV76-HGB2B

(B)=

(C)=

(D)=

(E)=

(F)=

No.	Lev.	Parts No.	Description	Q'ty						I	R
				(A)	(B)	(C)	(D)	(E)	(F)		
1	1	26106-100252	BOLT, M10X 25 PLATED	2							
2	1	119717-77010	STARTER, P1.1	1							
3	2	X0281007750	YOKE ASSY	1							
4	3	X0280996180	STARTER KIT	2							
5	2	X0285105190	HOLDER ASSY	1							
6	3	X0285205030	SPRING	4							
7	2	X0282005991	ARMATURE ASSY	1							
8	2	X0283006960	CLUTCH ASSY	1							
9	2	X4284001590	HOUSING ASSY,STARTER	1							
10	3	X9491050100	BEARING, NEEDLE	1							
11	2	X0285007030	FRAME ASSY.	1							
12	3	X9491040990	BEARING	1							
13	3	X0280626010	COVER	1							
14	2	X0284105040	BEARING ASSY	1							
15	3	X9491034330	BEARING	1							
16	2	X0286105010	SHAFT ASSY	1							
17	3	X9491034320	BEARING	1							
18	2	X0286305010	GEAR	3							
19	2	X0286355010	GEAR	1							
20	2	X0287405140	LEVER	1							
21	2	X0534007800	SWITCH ASSY	1							
22	2	X9055715000	RING	1							
23	2	X9490721360	RING	1							
24	2	X0280210331	NUT	1							
25	2	X9490138110	WASHER	1							
26	2	X9490138090	WASHER	1							
27	2	X9490138100	WASHER	1							
28	2	X0284525010	PLATE	1							
29	2	X9490562360	NUT	1							
30	2	X9490560750	NUT	2							
31	2	X9490423420	BOLT, THROUGH	2							
33	2	X9490065670	SCREW, M4X6	2							
34	2	X0280335350	COVER, TERMINAL	1							
35	2	X1289510130	NUT	1							

Fig.16. GENERATOR

(A)=3TNV76-HGB2B

(B)=

(C)=

(D)=

(E)=

(F)=

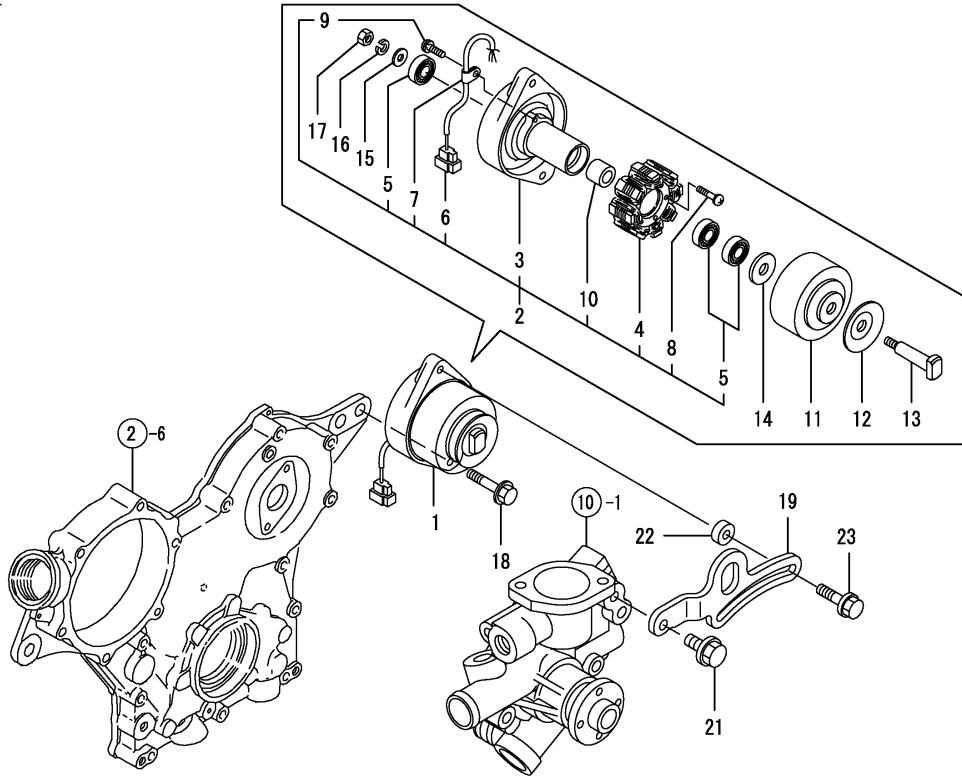

No.	Lev.	Parts No.	Description	Q'ty						I	R
				(A)	(B)	(C)	(D)	(E)	(F)		
1	1	171301-77201	DYNAMO ASSY, 15A	1							
2	2	XM08137	PLATE ASSY	1							
3	3	X2A07073KA	PLATE	1							
4	3	X4A07023KB	STATOR ASSY	1							
5	3	24104-062010	BEARING, 6201UUC3	3							
6	3	X417878	COUPLER	1							
7	3	XM069000000	CLAMP	1							
8	3	XYSPS402400	SCREW	2							
9	3	XYSPS400800	SCREW	1							
10	3	XM329830000	COLLAR	1							
11	2	X3A08877KA	FLYWHEEL	1							
12	2	XM721740000	PULLEY	1							
13	2	X4A07403K01	SHAFT	1							
14	2	XM67935	WASHER	1							
15	2	XM860250000	WASHER 10	1							
16	2	XM219230000	WASHER, SPRING	1							
17	2	XM863720000	NUT	1							
18	1	26106-100402	BOLT, M10X 40 PLATED	1							
19	1	119540-77310	ADJUSTER	1							
20	1	119233-77711	LIMITER, CURRENT	1							
21	1	26106-080202	BOLT, M8X 20 PLATED	1							
22	1	119940-77270	SPACER, GENERATOR	1							
23	1	129972-77341	BOLT, ADJUSTER L=50	1							
24	1	119650-77910	RELAY ASSY, GLOW	1							
27	1	129211-77920	TIMER	1							
28	1	119643-66900	DIODE	1							
29	1	119247-77100	RELAY, SAFETY	2							
30	1	171440-77801	RELAY, EMERGENCY	1							
31	1	119643-77900	CONNECTOR, STARTER	1							
32	1	129115-91250	SWITCH ASSY	1							
34	2	129115-91270	KEY ASSY	1							
35	1	170038-91310	UNIT, LAMP (RED)	1							

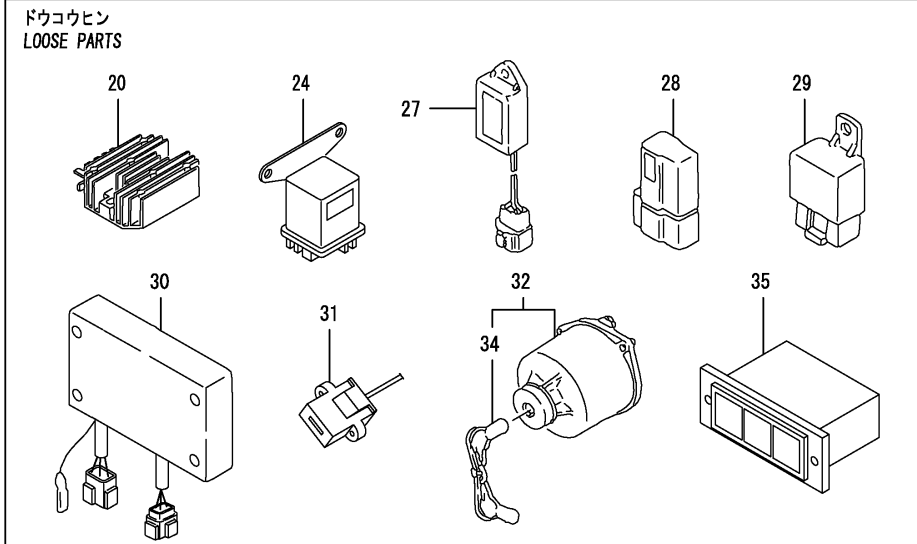

Fig.17. GASKET SET & TOOLS

(A)=3TNV76-HGB2B

(B)=

(C)=

(D)=

(E)=

(F)=

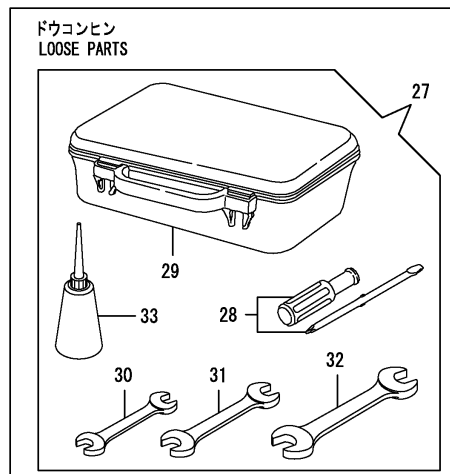
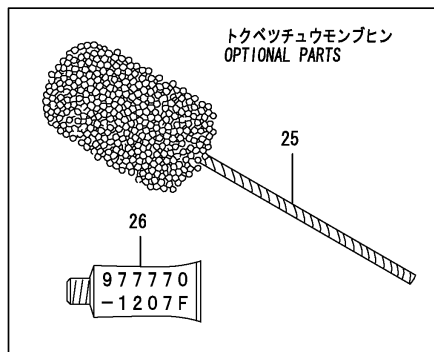
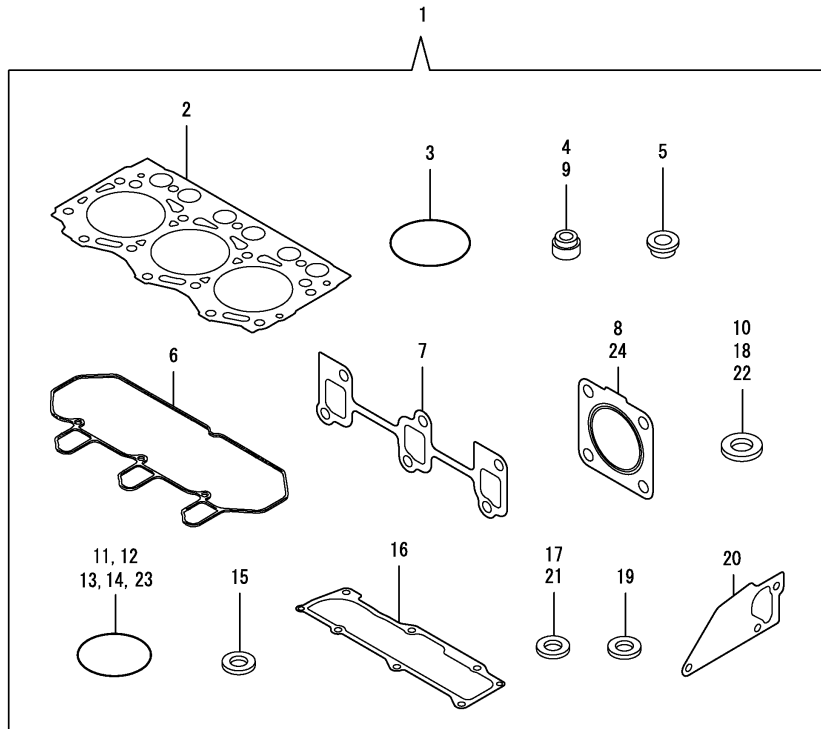

No.	Lev.	Parts No.	Description	Q'ty						I	R
				(A)	(B)	(C)	(D)	(E)	(F)		
1	1	719717-92800	GASKET SET	1							1
2	2	119717-01330	GASKET, HEAD	1							
3	2	121850-51960	O-RING	1							
4	2	119717-11340	SEAL, VALVE STEM	3							
5	2	129901-11450	PROTECTOR, NOZZLE	3							
6	2	119718-11310	GASKET, BONNET	1							
7	2	119717-13110	GASKET	1							
8	2	119515-13200	GASKET, SILENCER	1							
9	2	119717-11350	SEAL, VALVE STEM	3							
10	2	22190-080002	WASHER, SEAL 6	4							
11	2	24311-000320	O-RING, 1AP32.0	2							
12	2	119717-32060	O-RING, P15.0	1							
13	2	119624-32040	O-RING, P12.0	1							
14	2	119717-32050	O-RING, P17.0	3							
15	2	119600-11460	GASKET, NOZZLE	6							
16	2	119717-11331	GASKET	1							
17	2	124465-44950	GASKET, 16	2							
18	2	22190-120002	WASHER, SEAL 12	7							
19	2	129901-59560	GASKET	3							
20	2	119717-42020	GASKET, WATER PUMP	1							
21	2	23414-080000	GASKET, 8X1.0	1							
22	2	22190-160002	WASHER, SEAL 16	1							
23	2	24341-000240	O-RING, 1AS24.0	1							
24	2	129930-13201	GASKET, SILENCER	4							
25	1	129400-92420	FLEX HORN	1							1
26	1	977770-1207F	GASKET, LIQUID	1							1
27	1	721400-92102	BOX ASSY, TOOL	1							
28	2	104200-92350	DRIVER, SCREW	1							
29	2	104200-92600	BOX, TOOL	1							
30	2	28110-100120	SPANNER, 10X12	1							
31	2	28110-140170	SPANNER, 14X17	1							
32	2	28110-190220	SPANNER, 19X22	1							
33	2	28210-000140	OILER	1							

Remarks
(1) OPTIONAL PARTS.

Parts No. Index

Parts No.	Fig. No.	Ref. No.
101304-59020	14	13
101720-55750	14	31
102103-55520	14	5
		26
103854-39140	14	12
104200-55321	14	22
104200-55330	14	2
		23
104200-55341	14	24
104200-55750	14	9
		32
104200-92350	17	28
104200-92600	17	29
105010-11490	4	5
105025-59750	13	55
105225-59511	14	37
105311-01090	1	6
105425-01690	3	7
110250-55610	14	6
		27
114250-39450	9	5
118200-53010	13	2
118400-51370	11	55
119131-18320	6	5
119233-77711	16	20
119247-77100	16	29
119255-44660	10	43
119285-01990	1	9
119285-11990	4	15
119305-35151	9	2
119415-61440	12	21
119515-13200	6	7
	17	8
119515-42350	10	18
119515-53001	13	1
119515-53010	13	3
119515-59581	13	32
119527-61420	12	72
119540-77310	16	19
119600-11460	4	4
	17	15
119620-01750	3	13
119620-02020	1	10
119620-11280	4	30
119620-14200	7	1
119620-21941	8	14
119620-59700	13	43
119621-21680	8	13
119623-01250	1	7
119624-32040	2	20

Parts No.	Fig. No.	Ref. No.
119624-32040	17	13
119636-21590	8	8
119643-66900	16	28
119643-77900	16	31
119650-77910	16	24
119653-77950	12	135
119660-01911	2	19
119660-61300	12	79
119660-61901	12	66
119717-01330	1	31
	17	2
119717-01501	2	1
119717-01570	2	3
119717-01601	3	2
119717-01720	3	4
119717-01750	2	18
119717-01800	2	8
119717-02411	1	13
119717-03031	4	40
119717-03070	4	41
		42
119717-11101	4	17
119717-11110	4	18
119717-11131	4	19
119717-11190	4	21
119717-11200	4	25
119717-11240	4	26
119717-11260	4	29
119717-11331	4	55
	17	16
119717-11340	4	22
	17	4
119717-11350	4	23
	17	9
119717-11650	4	31
119717-11800	4	13
119717-13109	6	1
119717-13110	6	2
	17	7
119717-13600	6	3
119717-14400	7	2
119717-14581	7	3
119717-21200	8	6
119717-21650	8	12
119717-21700	8	1
119717-22080	8	15
119717-22090	8	31
119717-22300	8	21
119717-22500	8	17
119717-22550	8	33

Parts No.	Fig. No.	Ref. No.
119717-23000	8	23
119717-23200	8	28
119717-23601	8	29
119717-23611	8	37
119717-23910	8	27
119717-25050	7	10
119717-25101	7	11
119717-25930	7	16
119717-32050	2	21
	17	14
119717-32060	9	3
	17	12
119717-32080	2	11
119717-32100	2	10
119717-32110	2	15
119717-32120	2	16
119717-39210	9	6
119717-42002	10	1
119717-42020	10	13
	17	20
119717-42031	10	4
119717-42041	10	3
119717-42320	10	11
119717-49800	10	24
119717-51030	11	6
119717-51060	11	7
119717-51070	11	8
119717-51100	11	10
119717-51150	7	17
119717-51190	11	16
119717-51200	11	17
119717-51300	11	44
119717-51330	11	47
119717-51420	11	85
119717-51480	11	90
119717-51490	11	91
119717-51500	11	65
119717-51570	11	15
119717-51711	11	76
119717-51750	11	77
119717-51761	11	78
119717-55650	14	18
119717-59510	13	33
119717-61050	12	2
119717-61060	12	3
119717-61070	12	4
119717-61120	12	8
119717-61130	12	9
119717-61140	12	10
119717-61150	12	11

Parts No.	Fig. No.	Ref. No.
119717-61200	12	75
119717-61400	12	14
119717-61500	12	30
119717-77010	15	2
119717-77800	4	64
119717-77820	4	1
119718-11310	4	50
	17	6
119734-01580	2	4
119734-02220	3	3
119734-11320	4	51
119734-11340	4	53
119734-11380	4	39
119734-12200	5	1
119734-12510	5	9
119734-12601	5	2
119734-49010	10	44
119740-49060	10	45
119744-01521	2	6
119744-35080	9	13
119744-59560	13	40
119746-01790	3	6
119746-11740	4	6
119746-12500	5	8
119746-12560	5	19
119746-34801	9	12
119746-59810	13	20
119746-59820	13	24
119746-59830	13	28
119746-61200	12	5
119761-61560	12	99
119802-03100	4	43
119802-03110	4	44
119802-03121	4	45
119802-03131	4	46
119802-03141	4	47
119802-13620	6	4
119802-32130	2	17
119802-44560	10	42
119802-44600	10	40
119808-12540	5	11
119810-01200	1	30
119810-02931	1	27
119810-02941	1	32
119810-55340	14	3
119810-55650	14	8
119813-59950	13	44
119833-55620	14	1
119865-21600	8	11
119866-12541	5	12

Parts No. Index

Parts No.	Fig. No.	Ref. No.
119940-77270	16	22
119C10-42320	10	11 -1
119E10-42000	10	1 -1
121023-01551	2	33
121111-21501	8	39
121120-01620	3	15
121250-44901	10	27
121250-55620	14	7
121254-55510	14	4
121256-44600	10	37
121257-55720	14	28
121257-55731	14	29
121400-44910	10	46
121450-42450	10	26
121520-34810	9	11
121550-49111	10	17
121850-51960	2	22
	17	3
122710-51090	11	9
124060-01050	1	5
124064-55510	14	25
124066-59100	13	41
124160-01751	2	31
	4	38
124160-01910	1	8
124450-44510	10	30
124450-44530	10	32
124450-44550	10	36
124450-44560	10	33
124465-44950	10	28
	29	
	17	17
124550-51350	11	48
124764-44810	10	35
124766-59050	10	54
	13	53
	14	15
		36
126650-12680	5	18
129001-32320	2	13
129001-32330	2	14
129004-12520	5	10
129004-44500	10	38
129005-59830	9	7
129051-12530	5	13
129052-61390	12	13
129100-01580	3	1
	8	2
129100-35140	9	1
129100-51560	11	70

Parts No.	Fig. No.	Ref. No.
129100-51570	11	71
129100-52101	11	95
129100-61650	12	60
129107-44590	10	39
129115-91250	16	32
129115-91270	16	34
129136-59110	14	16
129150-11230	4	32
129150-11750	4	34
129150-25301	7	15
129150-49080	10	48
129150-49100	10	47
129150-59120	13	15
129150-59131	13	18
129155-51020	11	5
129155-51140	11	13
129155-51280	11	42
		43
	12	6
129155-51400	11	57
129155-51450	11	60
129155-51521	11	66
129155-51530	11	67
129155-51540	11	68
129155-51550	11	69
129155-51580	11	73
129155-51591	11	74
129155-51600	11	22
129155-51701	11	75
129155-52051	11	94
129155-61341	12	80
129155-61450	12	22
129155-61460	12	81
129155-61480	12	24
129156-61460	12	23
129209-61370	12	12
129209-61930	12	133
129209-61970	12	134
129210-49280	10	52
129210-59080	14	14
129210-59170	14	35
129211-77920	16	27
129255-61410	12	70
129259-12570	5	17
129335-55700	14	20
129350-49530	10	23
129400-92420	17	25
129418-12530	5	15
129457-44760	10	21
129457-59010	13	52

Parts No.	Fig. No.	Ref. No.
129486-61540	12	50
129508-11180	4	20
129573-61700	12	132
129601-13500	6	8
129612-12650	5	14
129612-42310	10	19
129900-32130	2	12
129901-11450	4	3
	17	5
129901-53800	13	4
129901-59560	13	39
	17	19
129916-49740	10	12
129930-13201	6	9
	17	24
129957-59120	13	54
129972-77341	16	23
158552-61700	12	61
158552-61710	12	65
158552-61900	12	84
158600-51170	11	14
158600-51270	11	41
158600-51410	11	58
158600-51420	11	59
158600-51442	11	49
158600-51570	11	72
158600-51790	11	79
158601-61700	12	91
170038-91310	16	35
171081-55910	14	33
171301-77201	16	1
171340-44740	10	20
171440-77801	16	30
174307-51700	12	31
22190-080002	9	8
		10
	17	10
22190-100002	12	73
22190-120002	12	82
	13	50
		51
	14	17
	17	18
22190-160002	3	9
	11	80
	17	22
22217-060000	11	81
22217-120000	7	18
22242-000120	4	35
22252-000220	8	22

Parts No.	Fig. No.	Ref. No.
22272-000030	12	67
22351-050010	11	82
22351-060012	4	24
22372-040000	12	83
22512-040120	8	5
22857-500100	4	56
		57
22857-500160	4	58
23000-054000	5	3
23000-060000	5	4
		20
23010-038000	10	55
23061-070230	10	34
23414-080000	10	14
	17	21
23414-120016	12	136
23418-060000	14	34
23857-030000	9	9
23876-005000	4	16
23876-030000	2	9
23887-100002	12	74
24101-060034	11	83
24101-063034	11	84
24104-062010	16	5
24311-000320	2	32
	4	60
	17	11
24311-240100	14	10
		21
24316-000150	11	56
24341-000070	12	68
24341-000240	2	34
	17	23
26013-080222	5	5
26014-060122	10	41
26014-080702	14	11
		38
26022-050122	11	86
26022-060162	11	87
26106-050102	11	88
26106-060102	9	4
	12	69
		85
26106-060122	2	23
	7	9
26106-060142	12	86
26106-060162	2	24
		35
26106-060202	4	61
	12	87

Parts No. Index

Parts No.	Fig. No.	Ref. No.
26106-060352	7	14
26106-060402	2	25
		26
26106-060452	10	22
	12	88
26106-060602	2	27
26106-060652	2	28
26106-060752	4	62
26106-060852	4	63
26106-080122	10	15
26106-080162	5	6
	14	19
26106-080202	10	25
	16	21
26106-080252	3	11
26106-080402	4	37
26106-080502	10	16
26106-080602	3	12
26106-100252	15	1
26106-100402	16	18
26206-100252	3	14
26216-080222	4	54
26306-080002	2	29
	5	7
	6	6
26577-060122	10	9
26716-060002	11	89
26716-120002	7	19
26736-120002	12	89
26756-060002	12	71
		90
26979-050162	4	36
27241-120000	1	14
27241-250000	10	10
28110-100120	17	30
28110-140170	17	31
28110-190220	17	32
28210-000140	17	33
49933-000138	4	59
719717-01561	1	1
719717-02901	1	15
719717-02911	1	35
719717-92800	17	1
719734-01510	2	5
719746-51320	11	1
721400-92102	17	27
977770-1207F	2	30
	3	10
	4	2
	17	26

Parts No.	Fig. No.	Ref. No.
X0280210331	15	24
X0280335350	15	34
X0280626010	15	13
X0280996180	15	4
X0281007750	15	3
X0282005991	15	7
X0283006960	15	8
X0284105040	15	14
X0284525010	15	28
X0285007030	15	11
X0285105190	15	5
X0285205030	15	6
X0286105010	15	16
X0286305010	15	18
X0286355010	15	19
X0287405140	15	20
X0534007800	15	21
X1289510130	15	35
X2A07073KA	16	3
X3A08877KA	16	11
X417878	16	6
X4284001590	15	9
X4A07023KB	16	4
X4A07403K01	16	13
X9055715000	15	22
X9490065670	15	33
X9490138090	15	26
X9490138100	15	27
X9490138110	15	25
X9490423420	15	31
X9490560750	15	30
X9490562360	15	29
X9490721360	15	23
X9491034320	15	17
X9491034330	15	15
X9491040990	15	12
X9491050100	15	10
XM069000000	16	7
XM08137	16	2
XM219230000	16	16
XM329830000	16	10
XM67935	16	14
XM721740000	16	12
XM860250000	16	15
XM863720000	16	17
XYSPTS400800	16	9
XYSPTS402400	16	8

Parts No.	Fig. No.	Ref. No.
-----------	----------	----------

Parts No.	Fig. No.	Ref. No.
-----------	----------	----------