

OCD10-M90900EN

PREFACE

1. This parts catalog is the first edition of 3TNV88-QTBC for Takeuchi Mfg. Co., Ltd.

Pub. No.: 000Y00D9090

Published: Jun.,2006

2. Model name

Engine model	Vehicle		Vehicle Made by
	Products	Model name	
3TNV88-QTBC	EXCAVATOR	A7C (Chinese spec.)	Takeuchi Mfg. Co., Ltd.

Directions for the Parts Catalog.

1. This Parts Catalog shows both standard and optional parts.
2. Parts may change without prior notice.
3. The following is an example of the Parts Catalog format.

REF.	LEV.	PARTS NO.	DESCRIPTION	Q'TY						I	R
				(A)	(B)	(C)	(D)	(E)	(F)		
1	1	729595-51390	FUEL INJECTION PUMP	1	1	1	1	1			1
1-1	1	729595-51391	FUEL INJECTION PUMP	1	1	1	1	1		N	1
		(A=E00185) (B=E00200)									
3	2	26022-060162	SCREW M 6X 16	9	9	9	9	9			
3-1	2	26022-060162	SCREW M 6X 16	4	4	4	4	4		K	
		(A=E00156) (B=E00156) (C=E00156) (D=E00156) (E=E00156)									
4	2	129470-51040	CAMSHAFT	1	1	1	1	1			
5	2	122710-51050	BEARING, ROLLER	2	2	2	2	2			
6	2	129470-51060	RETAINER	1	1	1	1	1			

Remarks
(1) BOOST COMPEMSATOR TYPE. OPTIONAL PART, TO E00155,(4JH-DT, 4JH-DTZ

① Ref. No.

The Ref. No. listed may not be in accordance with the illustration Ref. No.

(Ex.) Illustration No.

List Ref No.

1

1

(Before change)

1-1

(After change)

For interchangeable symbols N, R and K, illustrations for new parts may be abbreviated.

② Lev. (Level)

Level indication

The numbers below indicate the level of relativity towards the main part.

1 ----- Main parts (Assembly parts)

2 ----- Sub component included in " 1 ".

3 ----- Sub component included in " 2 ".

Note) Parts that are not for sale are partially illustrated but not listed.

③ Interchangeability Symbol

When a part change takes place, one of the following interchangeability symbols is indicated beside the part.

Symbol	Interchangeability	Contents note
N	Old $\begin{matrix} \leftarrow \text{Yes} \\ \text{No} \rightarrow \end{matrix}$ New	New Part is interchangeable for Old Part but Old Part is not interchangeable for New Part.
Q	Old $\begin{matrix} \leftarrow \text{No} \\ \text{Yes} \rightarrow \end{matrix}$ New	New Part is not interchangeable for Old Part but Old Part is interchangeable for New Part.
R	Old $\begin{matrix} \leftarrow \text{Yes} \\ \text{Yes} \rightarrow \end{matrix}$ New	New/ Old Parts are both interchangeable.
S	Old $\begin{matrix} \leftarrow \text{No} \\ \text{No} \rightarrow \end{matrix}$ New	New/ Old Parts are both not interchangeable.
W		Part newly added.
Z		Part discontinued.
F		Not interchangeable by a single part but interchangeable together with related parts.
K		Changes only for used parts quantities.

④ Effective Machine No.

When a part changes, the effective Machine No. will be indicated in the (A)-(F) column.

Product Symbol	Product No.	Product Symbol	Product No.
C	Clutch No. Compressor No.	F	Machine No. (Agricultural Equip.)
D	Drive No.	M	Machine No.
E	Engine No.		

Note 1) A date may follow the symbol. (Ex.) 1996.01

Note 2) "XXXXX" and "ZZZZZ" are for parts that could not be predicted or for engine models that could not be identified.

Note 3) (A=E00185) is the E (Engine Serial Number) for the column (A) model (in this case 4JH-DT) after the parts design change.

⑤ Remarks

Figures or alphabets (symbols) are entered in the remarks column.

The comments (remarks) on parts that are indicated at the bottom of the illustration are the same symbols as those stated above.

Contents

Fig. No. Fig. Name

3TNV88-QTBC

1. CYLINDER BLOCK
2. GEAR HOUSING
3. FLYWHEEL HOUSING & OIL SUMP
4. CYLINDER HEAD & BONNET
5. SUCTION MANIFOLD & AIR CLEANER
6. EXHAUST MANIFOLD & SILENCER
7. CAMSHAFT & DRIVING GEAR
8. CRANKSHAFT & PISTON
9. LUB.OIL SYSTEM
10. COOLING WATER SYSTEM
11. FUEL INJECTION PUMP
12. GOVERNOR
13. FUEL INJECTION VALVE
14. FUEL LINE
15. STARTING MOTOR
16. GENERATOR
17. TOOLS & GASKET SET

Fig. No. Fig. Name

Fig.1. CYLINDER BLOCK

(A)=3TNV88-QTBC

(B)=

(C)=

(D)=

(E)=

(F)=

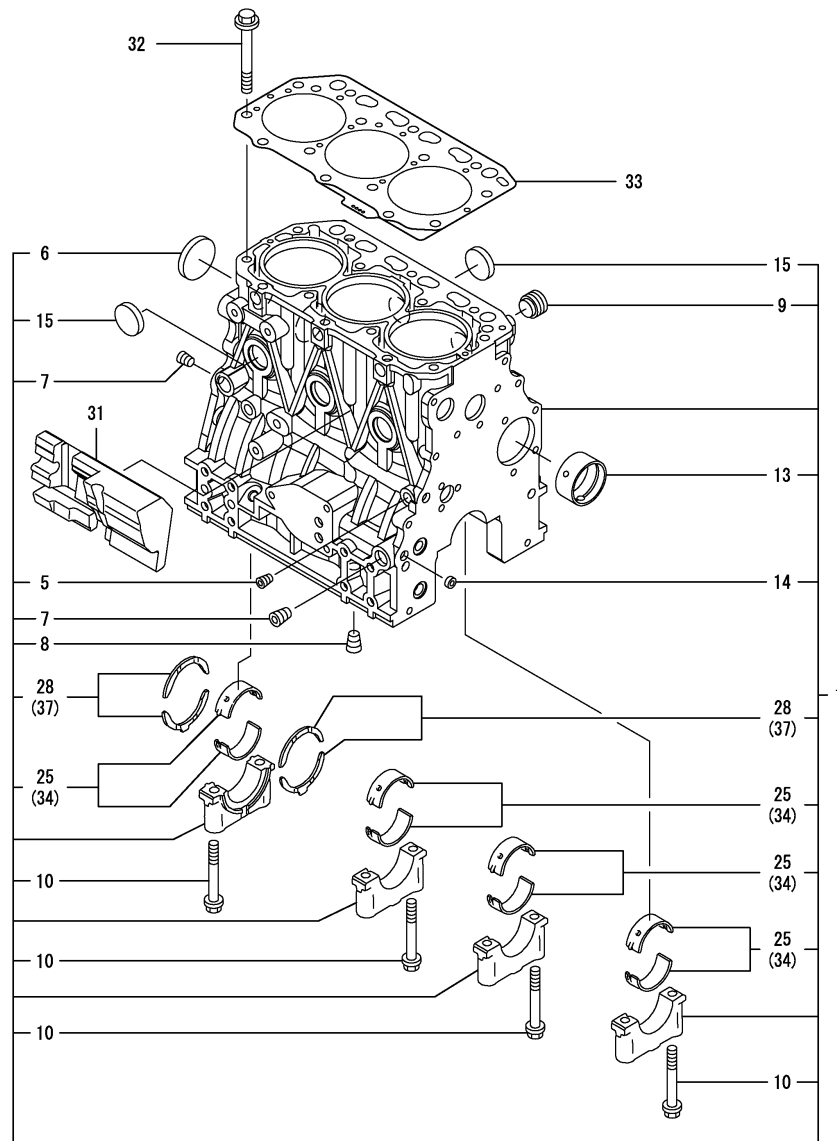

No.	Lev.	Parts No.	Description	Q'ty						I	R
				(A)	(B)	(C)	(D)	(E)	(F)		
1	1	729005-01562	BLOCK ASSY, CYLINDER	1							
5	2	124060-01050	PLUG, PT1/8	1							
6	2	129001-01250	PLUG, 50	1							
7	2	124160-01910	PLUG, PT1/4	2							
8	2	124160-01910	PLUG, PT1/4	1							
9	2	171051-01921	PLUG, NPTF1	1							
10	2	129150-02020	BOLT, METAL CAP	8							
13	2	129795-02412	BUSH, CAMSHAFT	1							
14	2	27241-120000	PLUG, 12	2							
15	2	27241-300000	PLUG 30	6							
25	2	129001-02931	BEARING, MAIN	4							3
28	2	129150-02931	BEARING, THRUST	2							
31	1	129004-01190	SPACER	1							
32	1	129150-01200	BOLT, HEAD	14							
33	1	129001-01340	GASKET, HEAD	1							
34	1	129150-02871	BEARING, 0.25 US	4							1
37	1	129150-02941	BEARING, THRUST 0.25	1							2

Remarks

- (1) UNDER-SIZE(U.S=0.25)PART.
- (2) OVER-SIZE(O.S=0.25)PART.
- (3) REPAIR PART.

Fig.2. GEAR HOUSING

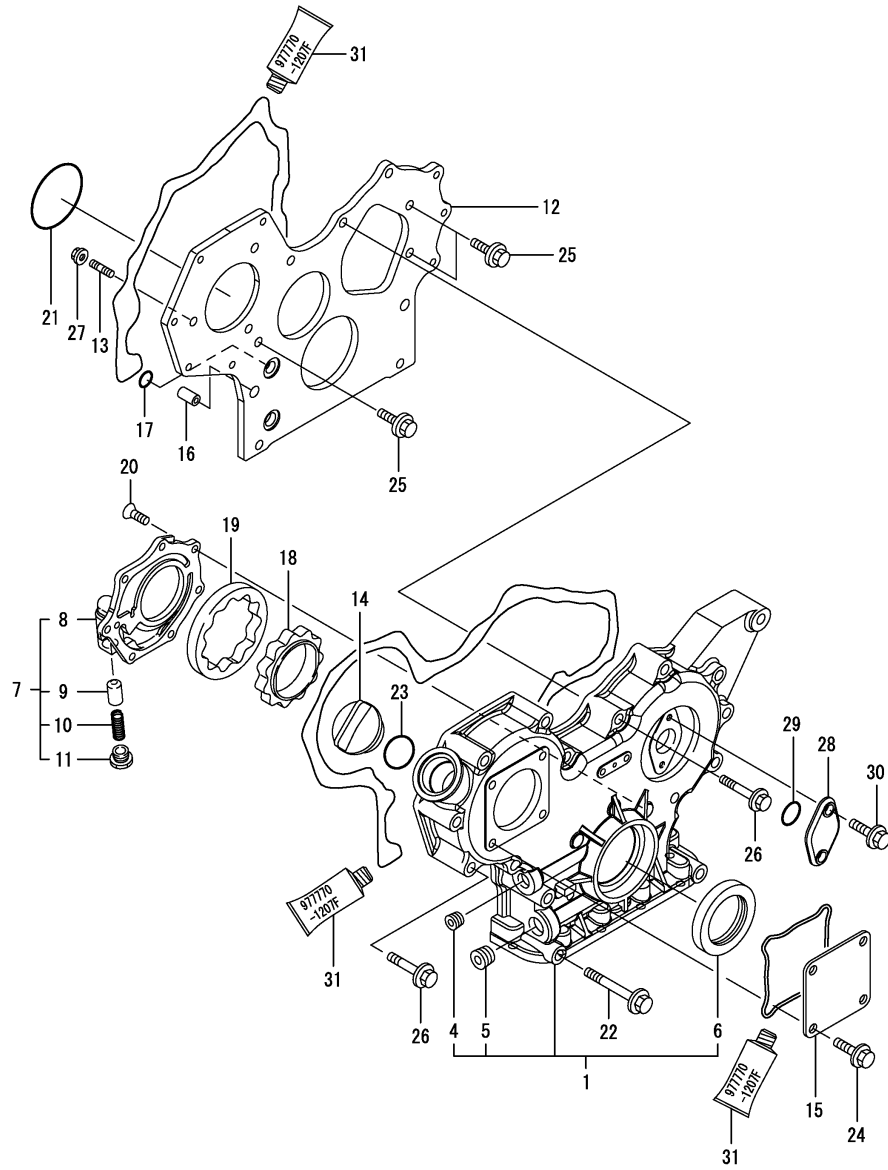

(A)=3TNV88-QTBC

(B)=

(C)=

(D)=

(E)=

(F)=

No.	Lev.	Parts No.	Description	Q'ty						I	R
				(A)	(B)	(C)	(D)	(E)	(F)		
1	1	729240-01500	CASE ASSY, GEAR	1							
4	2	23876-030000	PLUG, R03	1							
5	2	23876-040000	PLUG, R04	1							
6	2	119934-01800	SEAL, OIL	1							
7	1	119802-32100	COVER ASSY	1							
8	2	119802-32070	COVER	1							
9	2	129900-32130	VALVE, RELIEF	1							
10	2	129418-32320	SPRING	1							
11	2	129001-32330	PLUG	1							
12	1	119802-01520	FLANGE, GEAR CASE	1							
13	1	119802-01561	STUD, M8X25	3							
14	1	124160-01751	COVER, FILLER	1							
15	1	124240-01871	COVER	1							
16	1	129795-01950	PIPE, KNOCK L=18	2							
17	1	119609-32040	O-RING, P16	4							
18	1	119802-32111	ROTOR, INNER	1							
19	1	119802-32120	ROTOR, OUTER	1							
20	1	119802-32130	SCREW, M6X16	7							
21	1	121850-51960	O-RING	1							
22	1	129001-91841	BOLT, M8X85	3							
23	1	24311-000320	O-RING, 1AP32.0	1							
24	1	26106-080162	BOLT, M8X 16 PLATED	4							
25	1	26106-080162	BOLT, M8X 16 PLATED	3							
26	1	26106-080552	BOLT, M8X 55 PLATED	12							
27	1	26306-080002	NUT, M8	3							
28	1	121023-01551	COVER	1							
29	1	24341-000240	O-RING, 1AS24.0	1							
30	1	26106-060162	BOLT, M6X 16 PLATED	2							
31	1	977770-1207F	GASKET.LIQUID	1							1

Remarks
(1) OPTIONAL PART.

Fig.3. FLYWHEEL HOUSING & OIL SUMP

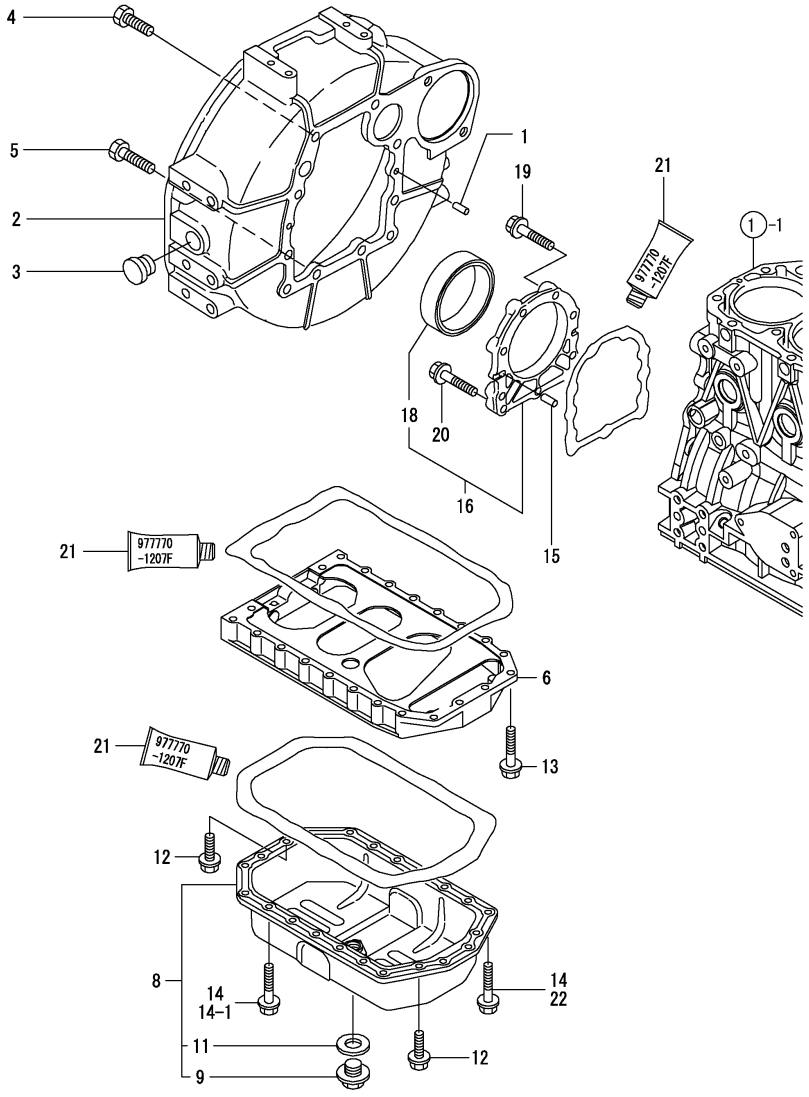

(A)=3TNV88-QTBC

(B)=

(C)=

(D)=

(E)=

(F)=

No.	Lev.	Parts No.	Description	Q'ty						I	R
				(A)	(B)	(C)	(D)	(E)	(F)		
1	1	129100-01580	PIN, M8X16	2							
2	1	129612-01600	HOUSING, FLYWHEEL	1							
3	1	119620-01750	CAP	1							
4	1	26206-100252	BOLT, M10X 25 PLATED	6							
5	1	26206-100302	BOLT, M10X 30 PLATED	4							
6	1	129100-01730	SPACER, OIL SUMP	1							
8	1	729102-01540	SUMP ASSY, OIL	1							
9	2	119640-01640	PLUG, DRAIN M22	1							
11	2	22190-220002	WASHER, SEAL 22	1							
12	1	26106-080162	BOLT, M8X 16 PLATED	4							
13	1	26106-080252	BOLT, M8X 25 PLATED	2							
14	1	26106-080452	BOLT, M8X 45 PLATED	20							
14-1	1	26106-080452	BOLT, M8X 45 PLATED	16							K
(A=FROM 1ST)											
15	1	129100-01580	PIN, M8X16	2							
16	1	129100-01640	CASE ASSY, OIL SEAL	1							
18	2	129795-01780	SEAL, OIL	1							
19	1	129486-01670	BOLT, M8X30	6							
20	1	26106-080352	BOLT, M8X 35 PLATED	3							
21	1	977770-1207F	GASKET.LIQUID	1							1
22	1	26106-080502	BOLT, M8X 50 PLATED	4							W
(A=FROM 1ST)											

Remarks
(1) OPTIONAL PART.

Fig.4. CYLINDER HEAD & BONNET

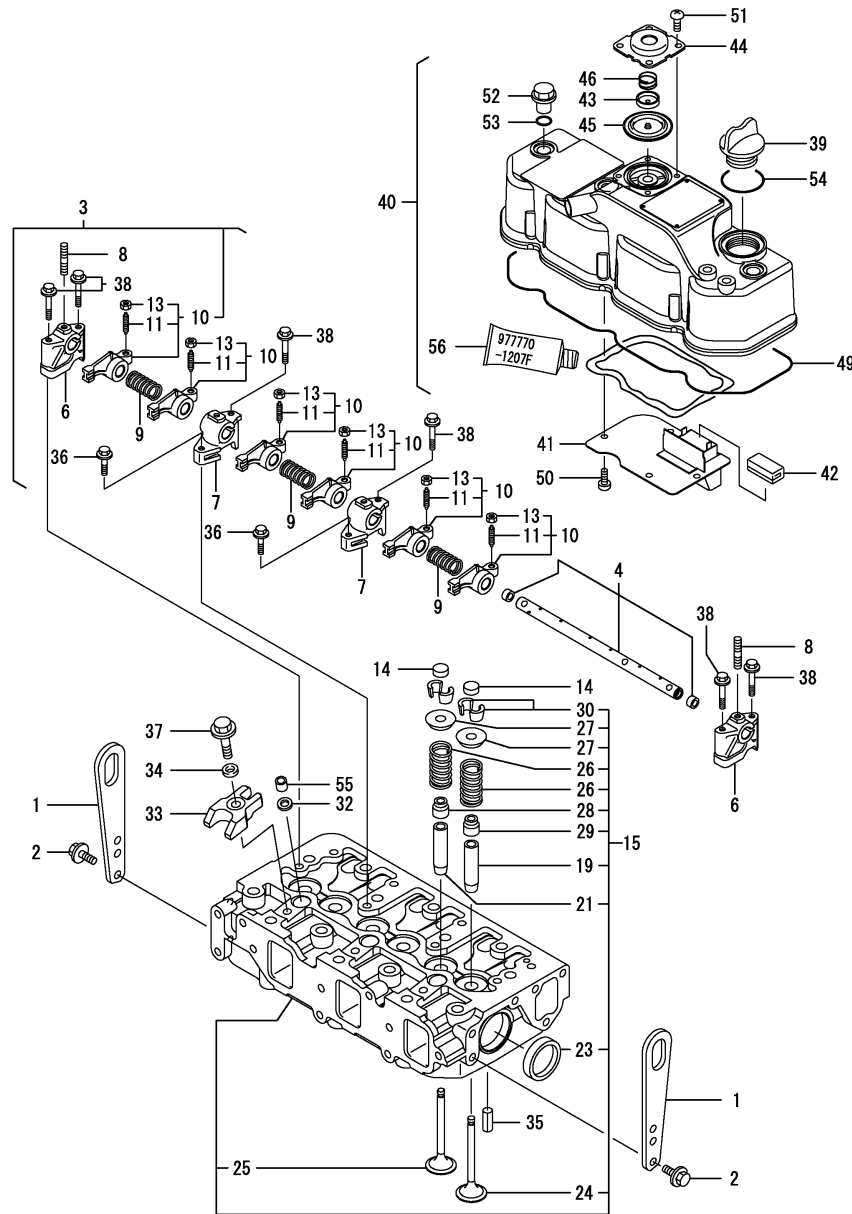

(A)=3TNV88-QTBC

(B)=

(C)=

(D)=

(E)=

(F)=

No.	Lev.	Parts No.	Description	Q'ty						I	R
				(A)	(B)	(C)	(D)	(E)	(F)		
1	1	129900-07900	LIFTER	2							
2	1	26106-080162	BOLT, M8X 16 PLATED	4							
3	1	129004-11241	SHAFT ASSY, ROCKER	1							
4	2	129004-11251	SHAFT, ROCKER ARM	1							
6	2	119802-11260	SUPPORT, ROCKER ARM	2							
7	2	119802-11270	SUPPORT, ROCKER ARM	2							
8	2	119802-11280	STUD	3							
9	2	129150-11280	SPRING	3							
10	2	129004-11650	ARM, ROCKER	6							
11	3	129150-11230	SCREW, VALVE ADJUST	6							
13	3	129150-11750	NUT, M8	6							
14	1	129150-11370	CAP, VALVE	6							
15	1	129004-11700	HEAD ASSY, CYLINDER	1							
19	2	120130-11860	GUIDE, VALVE	3							1
21	2	129150-11810	GUIDE, VALVE	3							1
23	2	27241-400000	PLUG, 40	2							
24	2	129004-11130	VALVE, INTAKE	3							
25	2	129100-11112	VALVE, EXHAUST	3							
26	2	129795-11120	SPRING, VALVE	6							
27	2	129795-11180	RETAINER, SPRING	6							
28	2	121400-11340	SEAL, VALVE STEM	3							
29	2	124460-11340	SEAL, VALVE STEM	3							
30	2	27310-080001	COTTER, 8	6							
32	1	119625-11880	SEAT, NOZZLE	3							
33	1	129004-11900	RETAINER, NOZZLE	3							
34	1	120270-54410	WASHER, INJECTOR	3							
35	1	22351-060012	PIN, SPRING 6.0X12	2							
36	1	26106-080252	BOLT, M8X 25 PLATED	2							
37	1	26106-080352	BOLT, M8X 35 PLATED	3							
38	1	26106-080502	BOLT, M8X 50 PLATED	6							
39	1	124160-01751	COVER, FILLER	1							
40	1	129004-11350	BONNET ASSY, HEAD	1							
41	2	129004-03010	PLATE	1							
42	2	129150-03070	BAFFLE, BREATHER	1							
43	2	119802-03110	PLATE	1							
44	2	119802-03121	COVER, DIAPHRAGM	1							
45	2	119802-03130	DIAPHRAGM	1							
46	2	119802-03141	SPRING, DIAPHRAGM	1							
49	2	129004-11310	GASKET, BONNET	1							
50	2	22857-500100	SCREW, 5X10	4							
51	2	22857-500100	SCREW, 5X10	4							
52	1	124160-11360	KNOB	3							
53	1	24311-000120	O-RING, 1AP12.0	3							
54	1	24311-000320	O-RING, 1AP32.0	1							
55	1	119802-11870	PROTECTOR, NOZZLE	3							
56	1	977770-1207F	GASKET, LIQUID	1							2

Remarks

- (1) REPAIR PARTS.
- (2) OPTIONAL PART.

Fig.5. SUCTION MANIFOLD & AIR CLEANER

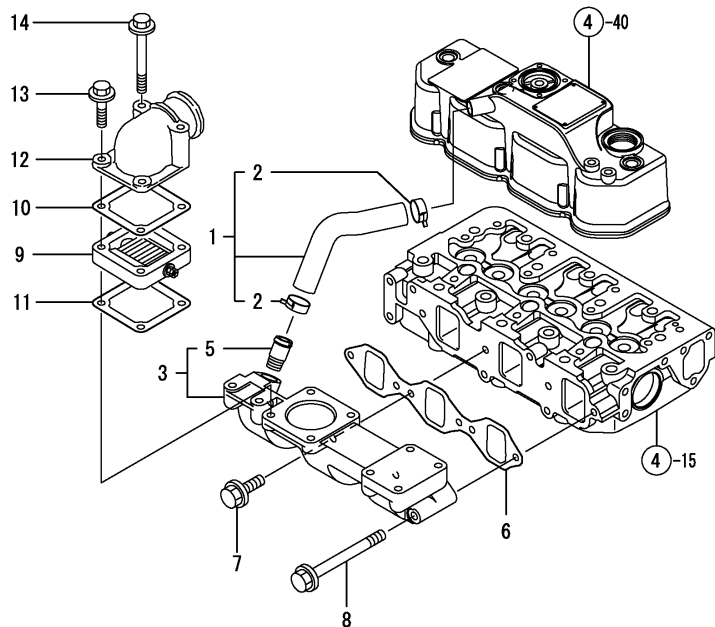
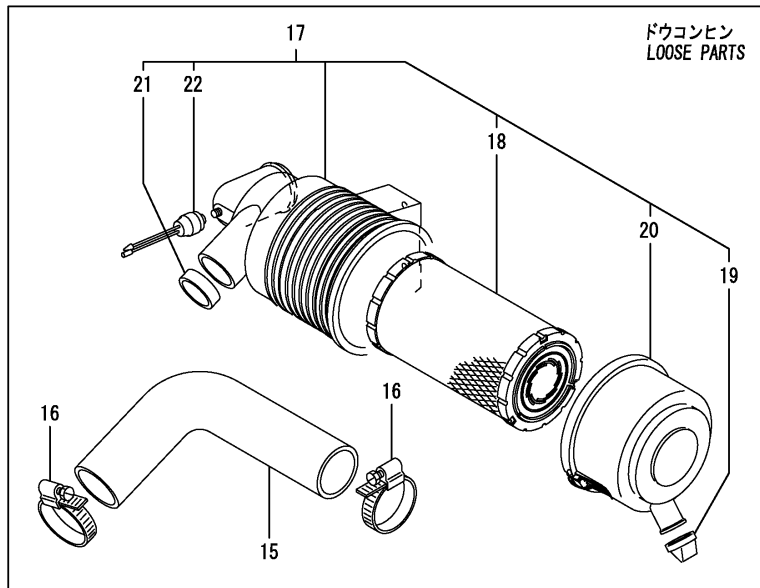

(A)=3TNV88-QTBC

(B)=

(C)=

(D)=

(E)=

(F)=

No.	Lev.	Parts No.	Description	Q'ty						I	R
				(A)	(B)	(C)	(D)	(E)	(F)		
1	1	129263-03080	PIPE ASSY, BREATHER	1							
2	2	129410-03990	CLAMP 22	2							
3	1	129263-12100	MANIFOLD, AIR INTAKE	1							
5	2	129263-12210	JOINT, BREATHER	1							
6	1	129150-12111	GASKET, MANIFOLD	1							
7	1	26106-080252	BOLT, M8X 25 PLATED	3							
8	1	26106-080702	BOLT, M8X 70 PLATED	1							
9	1	129100-77500	HEATER, AIR 12V	1							
10	1	129100-77510	GASKET, AIR HEATER	1							
11	1	129150-77511	GASKET	1							
12	1	171340-77520	BEND	1							
13	1	26106-080402	BOLT, M8X 40 PLATED	2							
14	1	26106-080802	BOLT, M8X 80 PLATED	2							
15	1	129030-12201	PIPE, AIR INTAKE	1							
16	1	23000-060000	CLAMP, 60	4							
17	1	129242-12500	CLEANER ASSY, AIR	1							
18	2	129904-12520	ELEMENT	1							
19	2	119808-12540	VALVE, UNLOADER	1							
20	2	119866-12541	COVER ASSY	1							
21	2	129259-12570	RING	1							
22	2	119140-12680	INDICATOR	1							

Fig.6. EXHAUST MANIFOLD & SILENCER

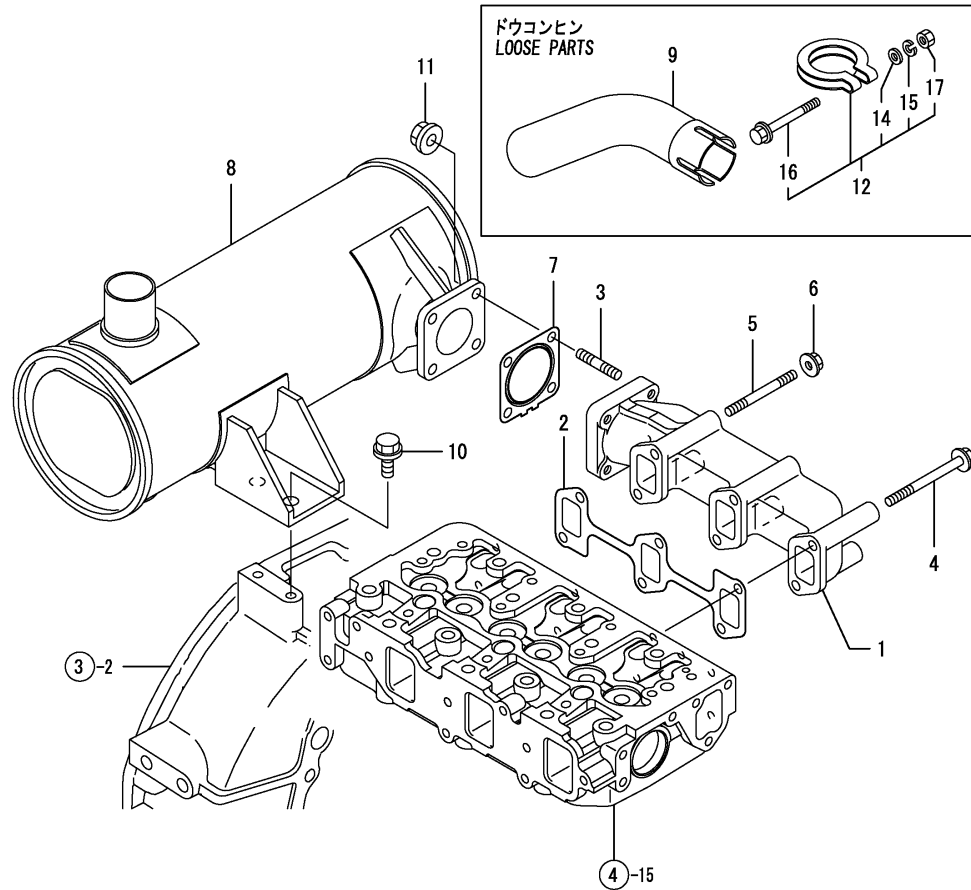

(A)=3TNV88-QTBC

(B)=

(C)=

(D)=

(E)=

(F)=

No.	Lev.	Parts No.	Description	Q'ty						I	R
				(A)	(B)	(C)	(D)	(E)	(F)		
1	1	129004-13129	MANIFOLD, EXHAUST	1							
2	1	129150-13110	GASKET	1							
3	1	119131-18320	STUD, M8X22	4							
4	1	123900-13630	BOLT, M8X80	4							
5	1	123900-13610	STUD, M8X80	2							
6	1	26306-080002	NUT, M8	2							
7	1	129004-13200	GASKET, SILENCER	1							
8	1	129242-13510	SILENCER	1							
9	1	129242-13650	PIPE	1							
10	1	26106-100202	BOLT, M10X 20 PLATED	2							
11	1	26306-080002	NUT, M8	4							
12	1	121120-13590	CLAMP	1							
14	2	22117-100000	WASHER, 10	1							
15	2	22217-100000	WASHER, SPRING 10	1							
16	2	26106-100652	BOLT, M10X 65 PLATED	1							
17	2	26706-100002	NUT, M10	1							

Fig.7. CAMSHAFT & DRIVING GEAR

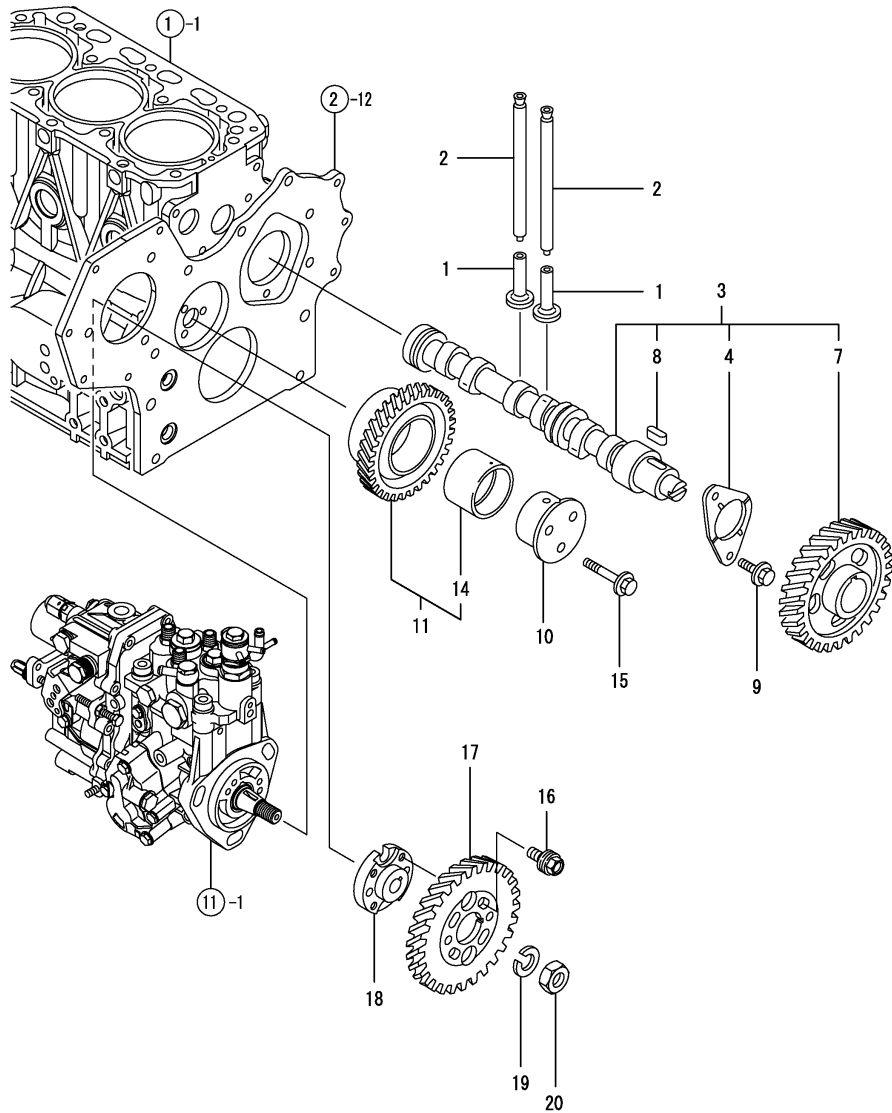

(A)=3TNV88-QTBC

(B)=

(C)=

(D)=

(E)=

(F)=

No.	Lev.	Parts No.	Description	Q'ty						I	R
				(A)	(B)	(C)	(D)	(E)	(F)		
1	1	129150-14200	TAPPET	6							
2	1	129150-14400	ROD, PUSH L=178	6							
3	1	129129-14580	CAMSHAFT ASSY	1							
4	2	129150-02450	BEARING, THRUST	1							
7	2	129150-14101	GEAR, CAMSHAFT	1							
8	2	22512-070140	KEY, 7X 14	1							
9	1	26106-080142	BOLT, M8X 14 PLATED	2							
10	1	119802-25051	SHAFT, IDLE	1							
11	1	119802-25101	GEAR ASSY, IDLE	1							
14	2	119802-25071	BUSH, IDLE GEAR	1							1
15	1	26106-080402	BOLT, M8X 40 PLATED	3							
16	1	129150-25301	BOLT	4							
17	1	119802-25901	GEAR, PUMP	1							
18	1	158552-51151	FLANGE	1							
19	1	22217-140000	WASHER, SPRING 14	1							
20	1	26776-140002	NUT, LOCK M14	1							

Remarks

(1) REPAIR PART.

Fig.8. CRANKSHAFT & PISTON

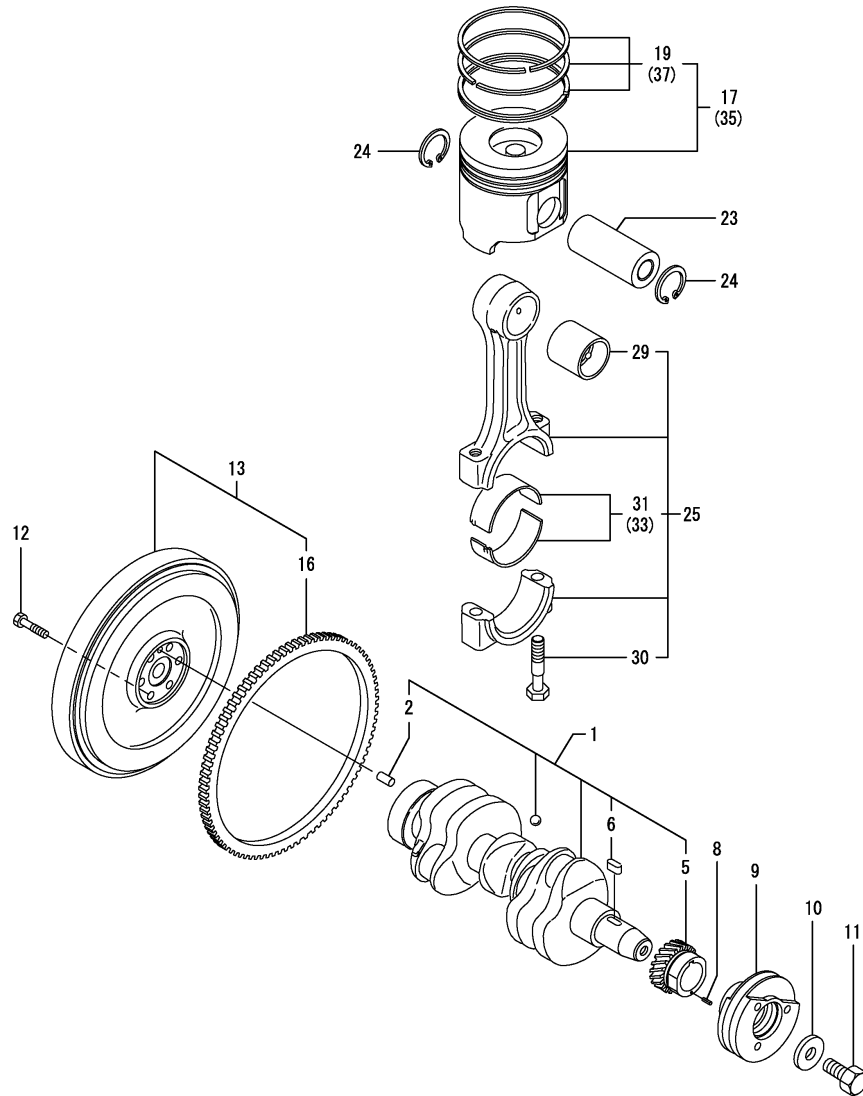

(A)=3TNV88-QTBC

(B)=

(C)=

(D)=

(E)=

(F)=

No.	Lev.	Parts No.	Description	Q'ty						I	R
				(A)	(B)	(C)	(D)	(E)	(F)		
1	1	129004-21002	CRANKSHAFT ASSY	1							
2	2	129100-01580	PIN, M8X16	1							
5	2	119802-21202	GEAR, CRANKSHAFT	1							
6	2	22512-070140	KEY, 7X 14	1							
8	1	22351-030010	PIN, SPRING 3.0X10	1							
9	1	129004-21650	V-PULLEY, 110	1							
10	1	129795-21661	WASHER	1							
11	1	121850-21680	BOLT	1							
12	1	121111-21501	BOLT, FLYWHEEL	6							
13	1	129002-21590	FLYWHEEL ASSY	1							
16	2	119865-21600	GEAR, RING	1							
17	1	129005-22080	PISTON ASSY	3							
19	2	129005-22500	RING SET, PISTON	3							
23	1	129202-22300	PIN, PISTON D26 L70	3							
24	1	22252-000260	RING, 26	6							
25	1	729402-23100	ROD ASSY, CONNECTING	3							
29	2	129100-23910	BEARING, PISTON PIN	3							1
30	2	121550-23200	BOLT, CONNECTING ROD	6							
31	2	129150-23601	BEARING, CRANK PIN	3							
33	1	129150-23611	BEARING, 0.25 US	3							2
35	1	129005-22900	PISTON ASSY, 0.25 OS	3							3
37	2	129005-22950	RING SET, 0.25 OS	3							3

Remarks

- (1) REPAIR PART.
- (2) UNDER-SIZE(U.S=0.25)PART.
- (3) OVER-SIZE(O.S=0.25)PART.

Fig.9. LUB.OIL SYSTEM

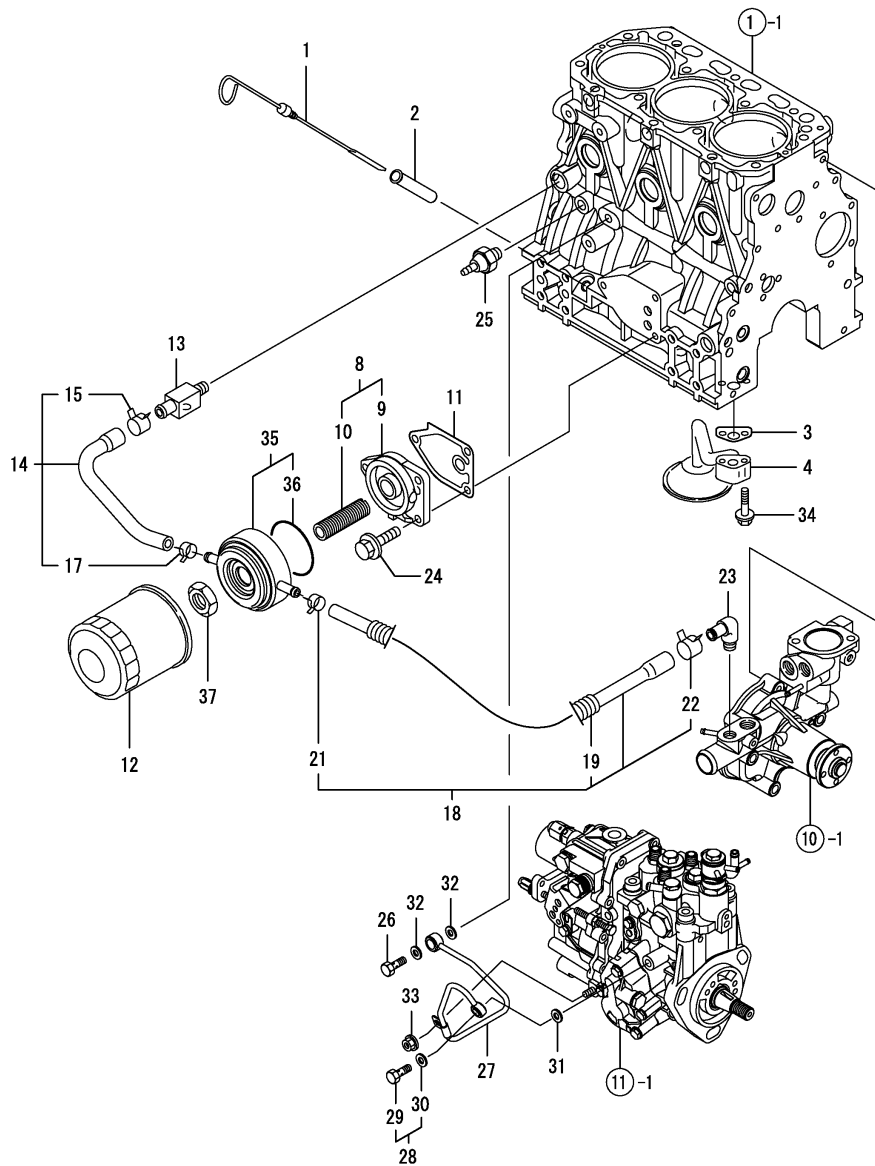

(A)=3TNV88-QTBC

(B)=

(C)=

(D)=

(E)=

(F)=

No.	Lev.	Parts No.	Description	Q'ty						I	R
				(A)	(B)	(C)	(D)	(E)	(F)		
1	1	129005-34802	DIPSTICK, OIL	1							
2	1	121520-34810	GUIDE, DIPSTICK	1							
3	1	129150-35042	GASKET	1							
4	1	129150-35091	PIPE ASSY, OIL INLET	1							
8	1	129006-35100	BRACKET ASSY, FILTER	1							
9	2	119802-35110	BRACKET, FILTER	1							
10	2	129417-35150	STUD, L=67	1							
11	1	129150-35111	GASKET	1							
12	1	119005-35151	FILTER, D80X100L	1							1
13	1	129006-44480	JOINT	1							
14	1	129508-49030	PIPE ASSY, WATER	1							
15	2	171008-03990	CLIP, HOSE 18.5	1							
17	2	23080-015000	CLAMP, 15	1							
18	1	129006-49040	PIPE ASSY, WATER	1							
19	2	129642-49180	TUBE, CORRUGATED	1							
21	2	23080-015000	CLAMP, 15	1							
22	2	23080-018000	CLAMP, 18	1							
23	1	129103-49301	ELBOW, PT1/4	1							
24	1	26106-080202	BOLT, M8X 20 PLATED	3							
25	1	114250-39450	SWITCH, 0.5KG	1							
26	1	124160-39140	BOLT, PIPE JOINT M10	1							
27	1	119802-39450	PIPE ASSY, OIL	1							
28	1	129005-59830	BOLT ASSY, JOINT M8	1							
29	2	23857-030000	BOLT, JOINT 3	1							
30	2	22190-080002	WASHER, SEAL 6	1							
31	1	22190-080002	WASHER, SEAL 6	1							
32	1	22190-100002	WASHER, SEAL 10	2							
33	1	26366-060002	NUT, M6	1							
34	1	26106-080352	BOLT, M8X 35 PLATED	2							
35	1	129508-33010	COOLER ASSY, OIL	1							
36	2	129508-33050	O-RING	1							
37	1	129417-33110	NUT	1							

Remarks

(1) REPAIR PART.

Fig.10. COOLING WATER SYSTEM

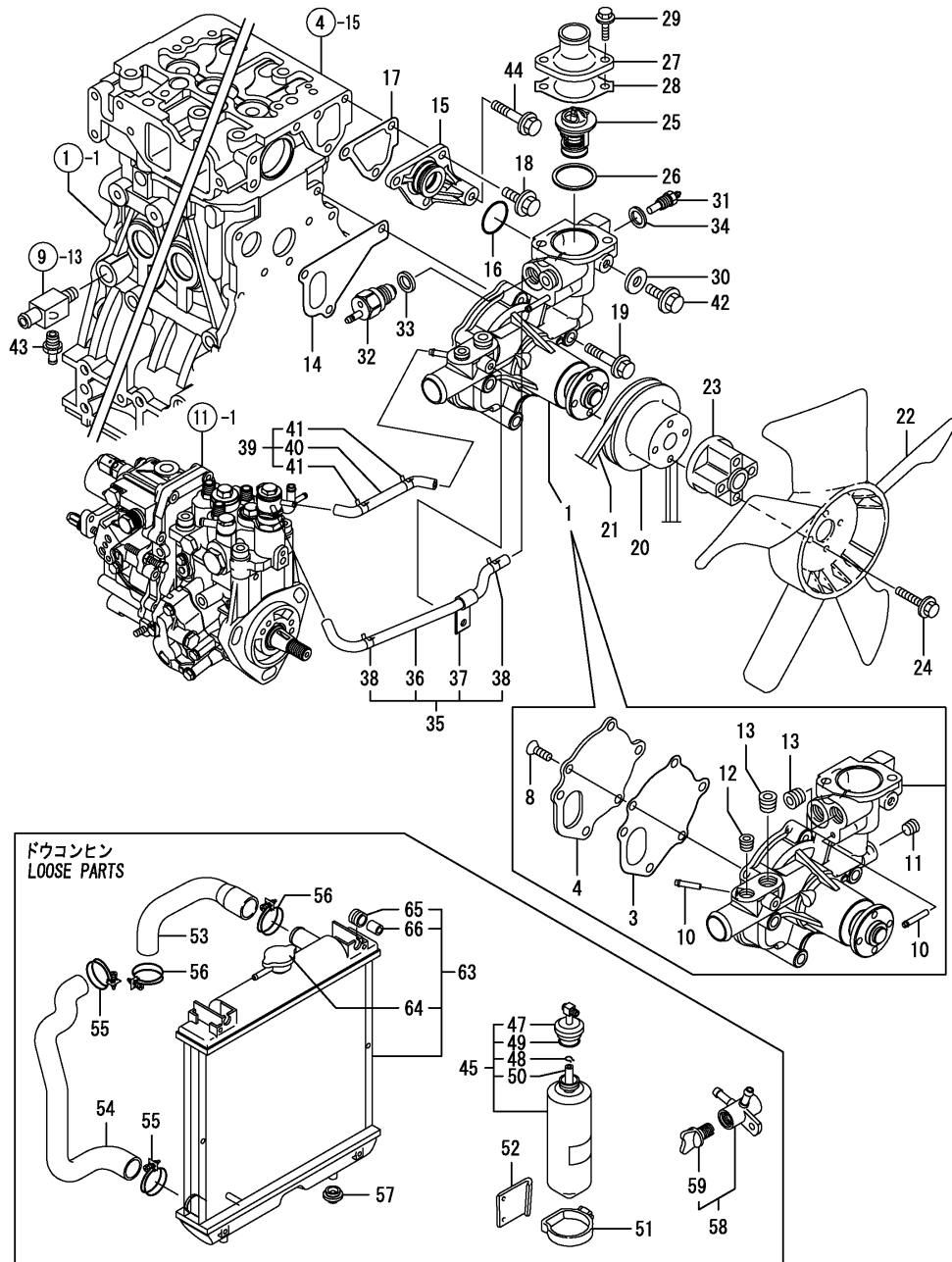

(A)=3TNV88-QTBC

(B)=

(C)=

(D)=

(E)=

(F)=

No.	Lev.	Parts No.	Description	Q'ty						I	R
				(A)	(B)	(C)	(D)	(E)	(F)		
1	1	129004-42001	PUMP ASSY, WATER	1							
3	2	129100-42051	GASKET, WATER PUMP	1							
4	2	129100-42121	PLATE	1							
8	2	121850-42410	SCREW	3							
10	2	119802-49113	JOINT, PIPE	2							
11	2	23876-010000	PLUG, R01	1							
12	2	23876-020000	PLUG, R02	1							
13	2	129916-49740	PLUG, R03	2							
14	1	129486-42021	GASKET, WATER PUMP	1							
15	1	129004-42040	JOINT	1							
16	1	129486-42140	O-RING, G30	1							
17	1	124395-49840	GASKET	1							
18	1	26106-080162	BOLT, M8X 16 PLATED	3							
19	1	26106-080602	BOLT, M8X 60 PLATED	3							
20	1	129155-42350	V-PULLEY	1							
21	1	129612-42290	V-BELT, A37.5	1							
22	1	129335-44740	FAN, COOLING D335	1							
23	1	129030-44760	SPACER, FAN L38.5	1							
24	1	26106-060502	BOLT, M6X 50 PLATED	4							
25	1	129457-49801	THERMOSTAT, 82	1							
26	1	129150-49811	GASKET, THERMOSTAT	1							
27	1	129350-49530	COVER, THERMOSTAT	1							
28	1	129795-49551	GASKET	1							
29	1	26106-080222	BOLT, M8X 22 PLATED	2							
30	1	23414-080000	GASKET, 8X1.0	1							
31	1	119266-49350	SWITCH	1							
32	1	121250-44901	SWITCH, 110	1							
33	1	124465-44950	GASKET, 16	1							
34	1	129150-49360	GASKET	1							
35	1	129004-49610	PIPE ASSY, WATER	1							
36	2	129004-49711	PIPE ASSY, WATER	1							
37	2	119802-49730	RETAINER, PIPE	1							
38	2	124722-59050	CLIP, HOSE 9	2							
39	1	129004-49620	PIPE ASSY, WATER	1							
40	2	129004-49721	PIPE ASSY, WATER	1							
41	2	124722-59050	CLIP, HOSE 9	2							
42	1	26106-080122	BOLT, M8X 12 PLATED	1							
43	1	121550-49111	JOINT, PT1/4	1							
44	1	26106-080452	BOLT, M8X 45 PLATED	1							
45	1	171064-44510	TANK ASSY, SUB	1							
47	2	121450-44531	CAP	1							
48	2	124450-44560	RETAINER	1							
49	2	121470-44581	GASKET	1							
50	2	23065-070225	HOSE 7X 225	1							
51	1	124450-44550	BAND	1							
52	1	121256-44600	BRACKET, SUB TANK	1							
53	1	129242-49010	PIPE, WATER	1							
54	1	129612-49040	PIPE, WATER	1							
55	1	23010-038000	CLAMP, 38	2							
56	1	23010-044000	CLAMP, 44	2							
57	1	119255-44660	ABSORBER	2							

Fig.10. COOLING WATER SYSTEM

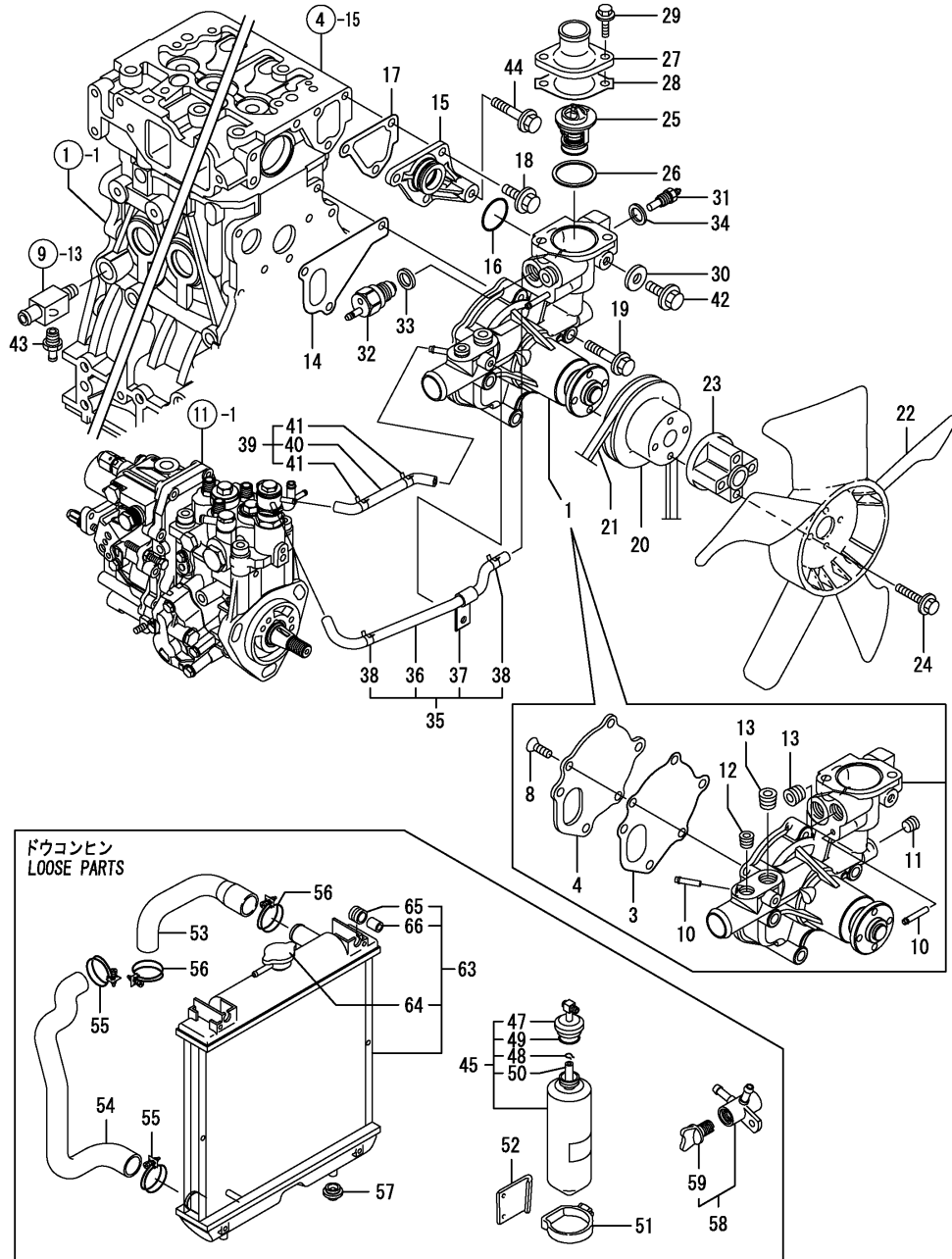

(A)=3TNV88-QTBC

(B)=

(C)=

(D)=

(E)=

(F)=

No.	Lev.	Parts No.	Description	Q'ty						I	R
				(A)	(B)	(C)	(D)	(E)	(F)		
58	1	129150-49100	COCK ASSY, 3-WAY	1							
59	2	129150-49080	COCK, DRAIN	1							
63	1	129642-44520	RADIATOR ASSY	1							
64	2	129107-44590	CAP, RADIATOR	1							
65	2	129467-44580	MOUNT, RUBBER	2							
66	2	129467-44590	COLLAR	2							

Fig.11. FUEL INJECTION PUMP

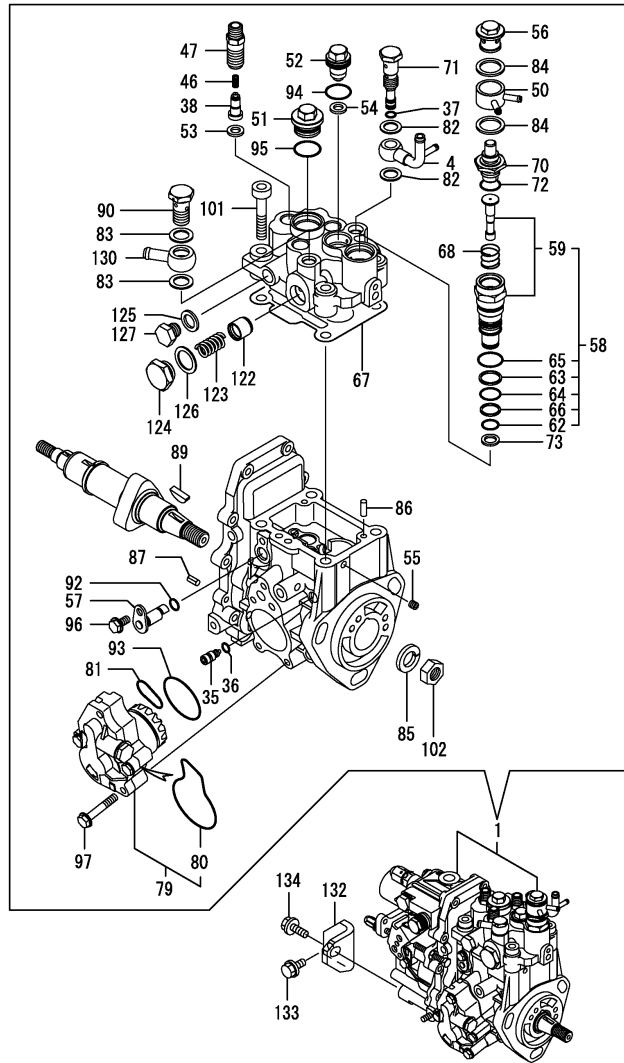

No.	Lev.	Parts No.	Description	Q'ty						I	R
				(A)	(B)	(C)	(D)	(E)	(F)		
1	1	729242-51400	PUMP ASSY, INJECTION	1							1
4	2	158552-51670	JOINT, OVER FLOW	1							
35	2	158600-51270	STOPPER, TAPPET	1							
36	2	158563-51281	O-RING, 4D S6	1							
37	2	158563-51281	O-RING, 4D S6	1							
38	2	158560-51300	VALVE ASSY, DELIVERY	3							
46	2	158563-51330	SPRING, DELIVERY	3							
47	2	158601-51340	HOLDER, DELIVERY	3							
50	2	158553-51551	JOINT	1							
51	2	158601-51550	PLUG	1							
52	2	119802-51560	PLUG, BARREL	1							
53	2	158552-51570	GASKET	3							
54	2	158552-51570	GASKET	1							
55	2	158557-51570	PLUG	1							
56	2	158601-51570	PLUG	1							
57	2	158552-51580	LIFTER	1							
58	2	119802-51590	TIMER SET	1							
59	3	119802-51600	TIMER ASSY	1							
62	3	158553-51670	O-RING, 1011	1							
63	3	119802-51680	RING, BACK UP	1							
64	3	119802-51690	O-RING	1							
65	3	24356-010200	O-RING, 4D1020	1							
66	3	24372-000150	RING, BACK UP T2P15	1							
67	2	158552-51600	GASKET	1							
68	2	158553-51630	SPRING, TIMER	1							
70	2	158553-51640	ELEMENT	1							
71	2	158601-51650	JOINT, OVER FLOW	1							
72	2	158553-51660	O-RING, P14	1							
73	2	158553-51680	GASKET	1							
79	2	158552-52100	PUMP ASSY, FUEL FEED	1							
80	3	158552-52500	O-RING	1							
81	2	158552-52310	O-RING	1							
82	2	22190-120002	WASHER, SEAL 12	2							
83	2	22190-120002	WASHER, SEAL 12	2							
84	2	22190-180002	WASHER, SEAL 18	2							
85	2	22217-140000	WASHER, SPRING 14	1							
86	2	22312-050140	PIN, PARALLEL M5X14	2							
87	2	22351-050010	PIN, SPRING 5.0X10	2							
89	2	119802-51090	KEY, 4X16	1							
90	2	23857-060000	BOLT, JOINT 6	1							
92	2	24311-000070	O-RING, 1AP7.0	1							
93	2	158552-52400	O-RING, 4E S42	1							
94	2	24356-010180	O-RING, 4D1018	1							
95	2	24356-010200	O-RING, 4D1020	1							
96	2	26106-060102	BOLT, M6X 10 PLATED	1							
97	2	158553-51770	BOLT	4							
101	2	26450-080452	BOLT, M8X 45	4							
102	2	26776-140002	NUT, LOCK M14	1							
122	2	158601-51770	PISTON	1							
123	2	158552-51780	SPRING	1							
124	2	158601-51790	PLUG	1							

Remarks
 (1) GOVERNOR ASSY(FIG.12) IS
 INCORPORATED IN THIS FOP.CMP
 (REF.NO.1).

Fig.11. FUEL INJECTION PUMP

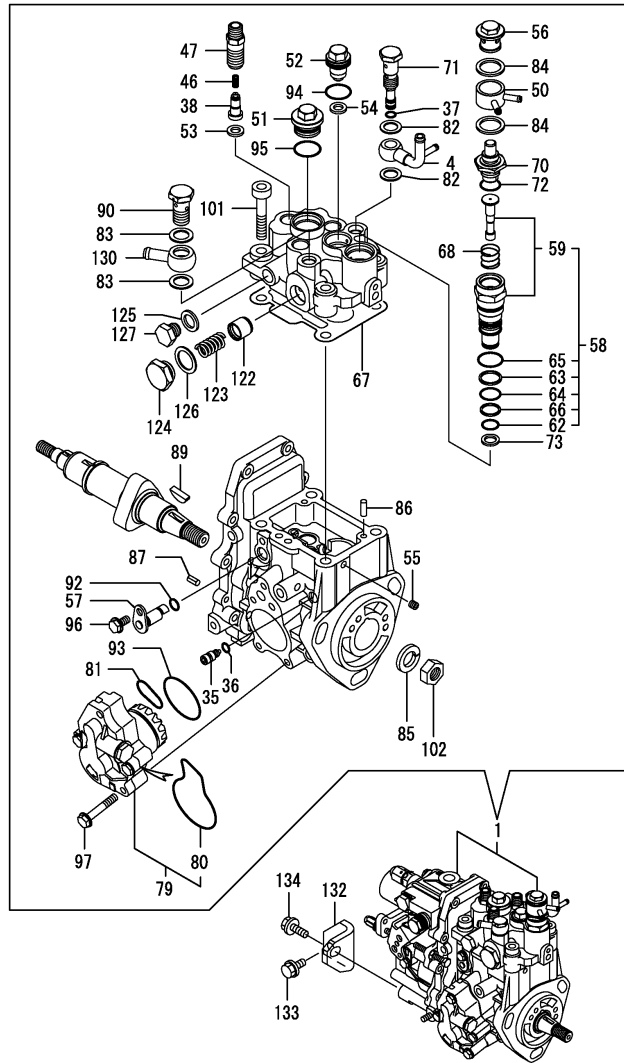

(A)=3TNV88-QTBC

(B)=

(C)=

(D)=

(E)=

(F)=

No.	Lev.	Parts No.	Description	Q'ty						I	R
				(A)	(B)	(C)	(D)	(E)	(F)		
125	2	22190-120002	WASHER, SEAL 12	1							
126	2	22190-180002	WASHER, SEAL 18	1							
127	2	23887-120002	PLUG, 12	1							
130	2	129916-59020	JOINT, PIPE 12	1							
132	1	119802-51250	RETAINER, PUMP	1							
133	1	26106-080162	BOLT, M8X 16 PLATED	1							
134	1	26106-080202	BOLT, M8X 20 PLATED	1							

Remarks

(1) GOVERNOR ASSY(FIG.12) IS INCORPORATED IN THIS FOP.CMP (REF.NO.1).

Fig.12. GOVERNOR

(A)=3TNV88-QTBC

(B)=

(C)=

(D)=

(E)=

(F)=

Q'ty

No.	Lev.	Parts No.	Description	Q'ty						I	R
				(A)	(B)	(C)	(D)	(E)	(F)		
2	2	158553-61050	GASKET	1							
3	2	158553-61070	GASKET	1							
5	2	129155-51280	O-RING, S6	1							
21	2	129255-61410	NUT, LOCK	1							
22	2	119807-61420	SPRING, RETURN	1							
23	2	158552-61441	LEVER, REGULATOR	1							
24	2	129155-61460	BOLT, IDLE	1							
53	2	26106-060102	BOLT, M6X 10 PLATED	1							
59	2	119660-61901	RETAINER, SHAFT	1							
63	2	22190-120000	WASHER, SEAL 12	1							
65	2	23887-120002	PLUG, 12	1							
67	2	26106-060102	BOLT, M6X 10 PLATED	1							
68	2	26756-060002	NUT, LOCK M6	1							
82	2	158552-61900	O-RING	1							
83	2	26106-060142	BOLT, M6X 14 PLATED	2							
84	2	26106-060142	BOLT, M6X 14 PLATED	4							
85	2	26106-060202	BOLT, M6X 20 PLATED	10							
96	2	119233-77932	SOLENOID, STOP	1							
97	2	129642-61060	COVER, GOVERNOR CASE	1							

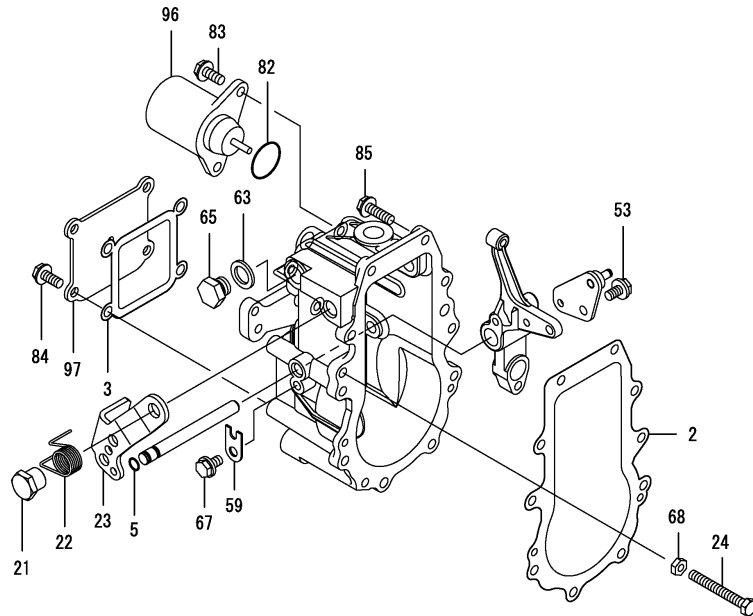

Remarks

* THIS FIGURE(GOVERNOR ASSY)IS INCORPORATED IN THE FUEL INJECTION PUMP ASSY(FIG.11).

Fig.13. FUEL INJECTION VALVE

(A)=3TNV88-QTBC

(B)=

(C)=

(D)=

(E)=

(F)=

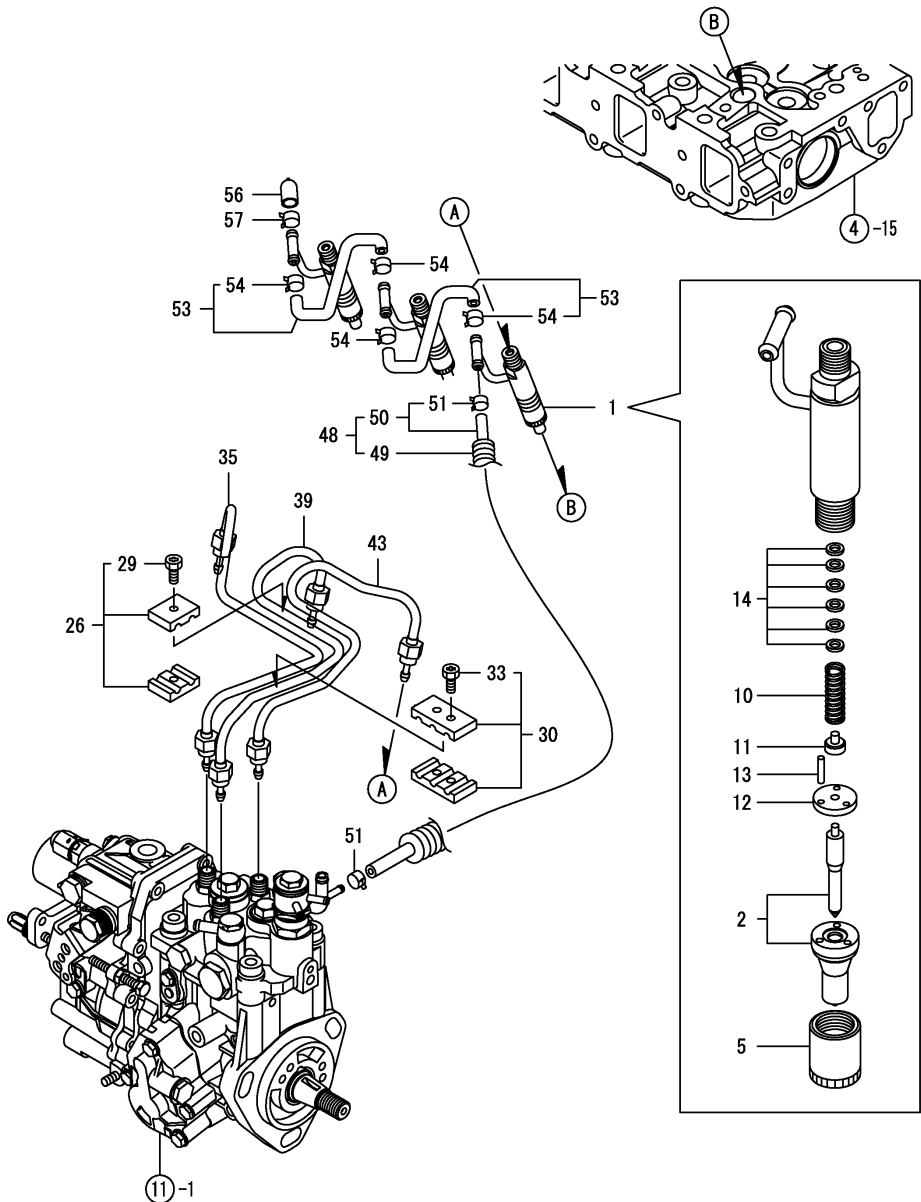

No.	Lev.	Parts No.	Description	Q'ty						I	R
				(A)	(B)	(C)	(D)	(E)	(F)		
1	1	729245-53100	VALVE ASSY,INJECTION	3							
2	2	129004-53001	VALVE ASSY,INJECTION	3							
5	2	114250-53080	NUT, NOZZLE D16.95	3							
10	2	114250-53120	SPRING, NOZZLE	3							
11	2	114250-53130	SEAT, SPRING	3							
12	2	114250-53140	PLATE	3							
13	2	114250-53210	PIN	6							
14	2	114250-53400	SHIM SET	3							
26	1	119305-59120	RETAINER, PIPE	1							
29	2	129150-59131	BOLT, M4X14	1							
30	1	129150-59120	RETAINER, PIPE	1							
33	2	129150-59131	BOLT, M4X14	2							
35	1	129263-59810	PIPE ASSY, INJECTION	1							
39	1	129263-59820	PIPE ASSY, INJECTION	1							
43	1	129263-59830	PIPE ASSY, INJECTION	1							
48	1	129263-59550	PIPE ASSY, RETURN	1							
49	2	129486-59320	TUBE, CORRUGATED	1							
50	2	119802-59550	PIPE ASSY, RETURN	1							
51	3	124722-59050	CLIP, HOSE 9	2							
53	1	129486-59551	PIPE ASSY, RETURN	2							
54	2	124722-59050	CLIP, HOSE 9	4							
56	1	119593-59581	CAP	1							
57	1	124060-77680	CLIP, HOSE 10	1							

Fig.14. FUEL LINE

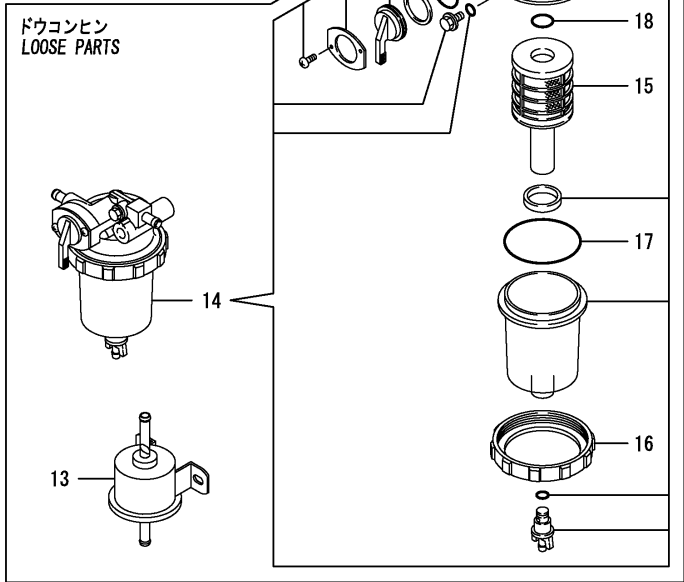
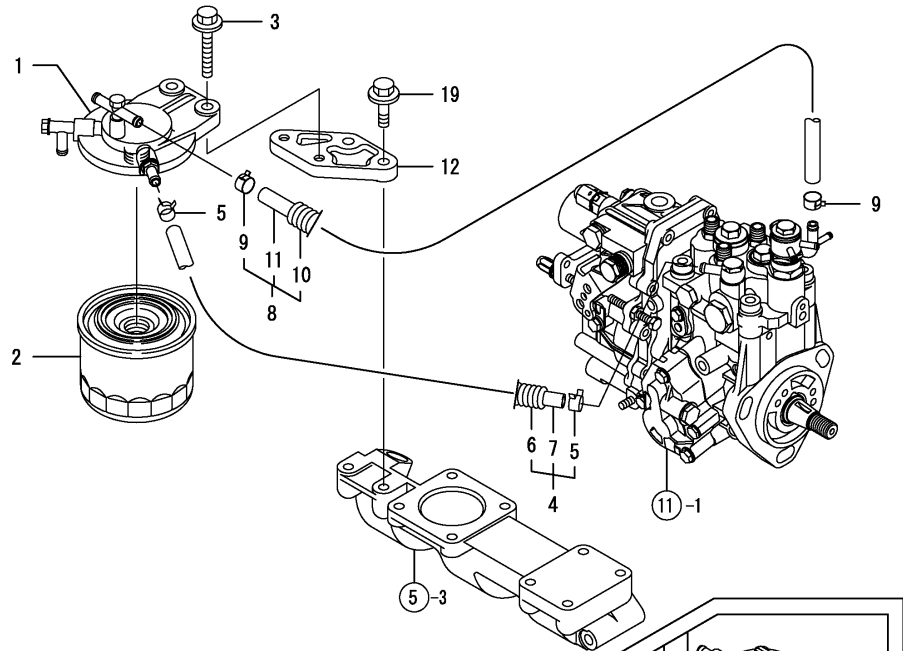

(A)=3TNV88-QTBC

(B)=

(C)=

(D)=

(E)=

(F)=

No.	Lev.	Parts No.	Description	Q'ty						I	R
				(A)	(B)	(C)	(D)	(E)	(F)		
1	1	129004-55612	BRACKET, FILTER	1							
2	1	129907-55801	FILTER, FUEL	1							
3	1	26106-080302	BOLT, M8X 30 PLATED	2							
4	1	129044-59010	PIPE, D13/7.5X220	1							
5	2	124766-59050	CLIP, HOSE 12	2							
6	2	129044-59100	TUBE, CORRUGATED	1							
7	2	129044-59510	PIPE, FUEL 220	1							
8	1	129950-59311	PIPE, FUEL	1							
9	2	124766-59050	CLIP, HOSE 12	2							
10	2	129961-59110	TUBE, CORRUGATED	1							
11	2	105025-59580	PIPE, FUEL	1							
12	1	119940-55690	SPACER	1							
13	1	129612-52100	PUMP ASSY, FUEL FEED	1							
14	1	129906-55700	SEPARATOR ASSY	1							
15	2	119802-55710	ELEMENT	1							
16	2	129100-55690	RING, RETAINING	1							
17	2	24321-000650	O-RING, 1AG65.0	1							
18	2	24311-000160	O-RING, 1AP16.0	1							
19	1	26106-080252	BOLT, M8X 25 PLATED	2							

Fig.15. STARTING MOTOR

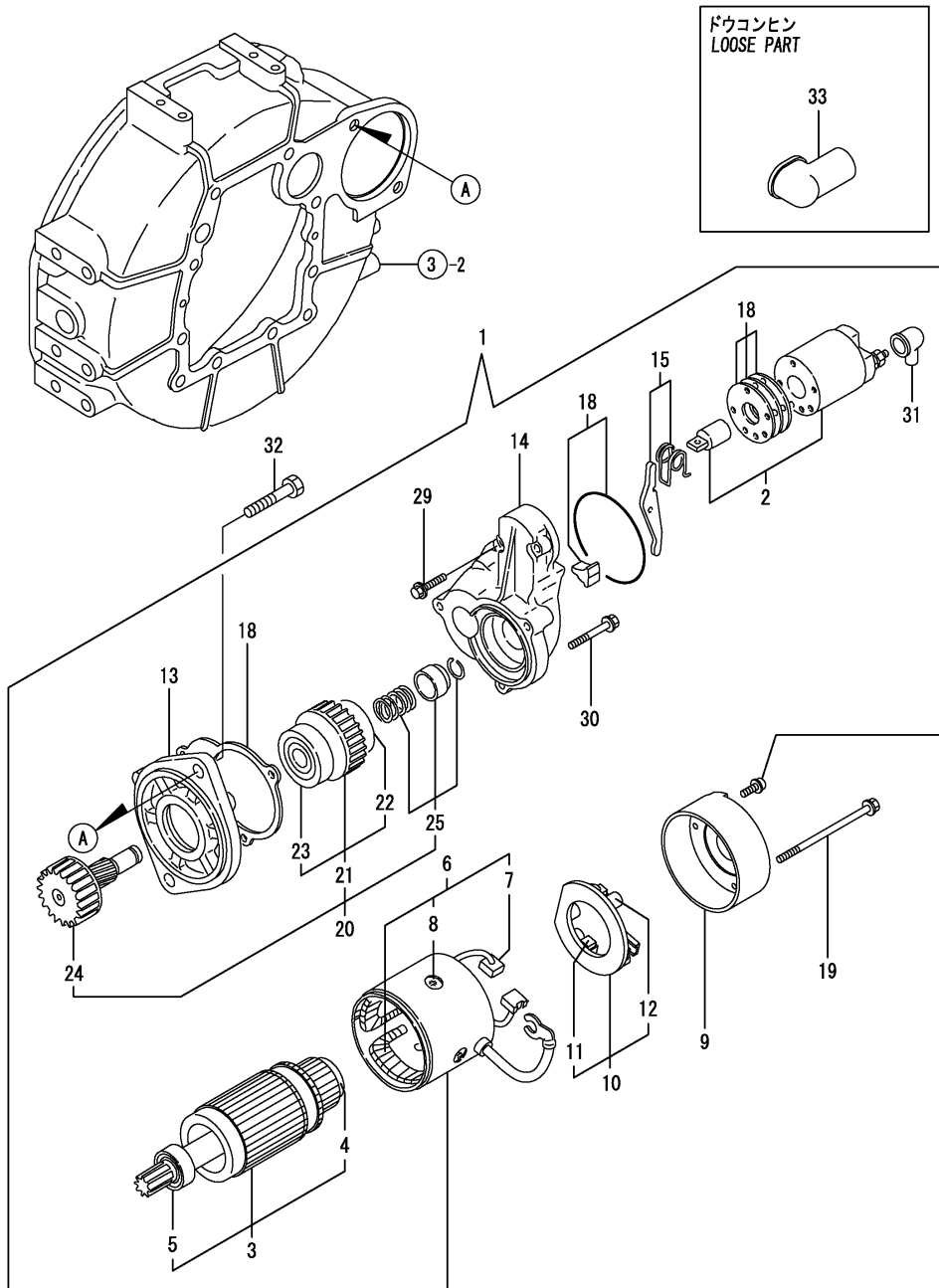

(A)=3TNV88-QTBC

(B)=

(C)=

(D)=

(E)=

(F)=

No.	Lev.	Parts No.	Description	Q'ty						I	R
				(A)	(B)	(C)	(D)	(E)	(F)		
1	1	129136-77011	STARTER	1							
2	2	129136-77310	SWITCH ASSY	1							
3	2	129900-77400	ARMATURE ASSY	1							
4	3	X2130350900	BALL BEARING	1							
5	3	X2114255110	BEARING, BALL	1							
6	2	129900-77440	COIL ASSY, FIELD	1							
7	3	129900-77450	BRUSH (+)	2							
8	3	171008-77450	SCREW	4							
9	2	129900-77460	COVER, REAR	1							
10	2	129900-77480	HOLDER ASSY, BRASH	1							
11	3	129900-77450	BRUSH (+)	2							
12	3	129400-77490	SPRING, BRUSH	4							
13	2	171008-77510	HOUSING ASSY, GEAR	1							
14	2	129136-77520	CENTER HOUSING	1							
15	2	171008-77540	LEVER SET, SHIFT	1							
18	2	129400-77571	DUST COVER,(NON-ASB.	1							
19	2	129900-77640	BOLT, THROUGH	2							
20	2	171008-77650	PINION ASSY	1							
21	3	X2114555500	CLUTCH ASSY	1							
22	4	X2114955020	BALL BEARING	1							
23	4	X2240410100	BEARING, BALL	1							
24	3	171008-77660	SHAFT, PINION	1							
25	3	171008-77670	STOPPER SET, PINION	1							
29	2	26106-060322	BOLT, M6X 32 PLATED	2							
30	2	26106-060402	BOLT, M6X 40 PLATED	3							
31	2	171008-77750	COVER, M TERMINAL	1							
32	1	26116-120252	BOLT, M12X 25 PLATED	2							
33	1	124550-77030	COVER, TERMINAL	1							

Fig.16. GENERATOR

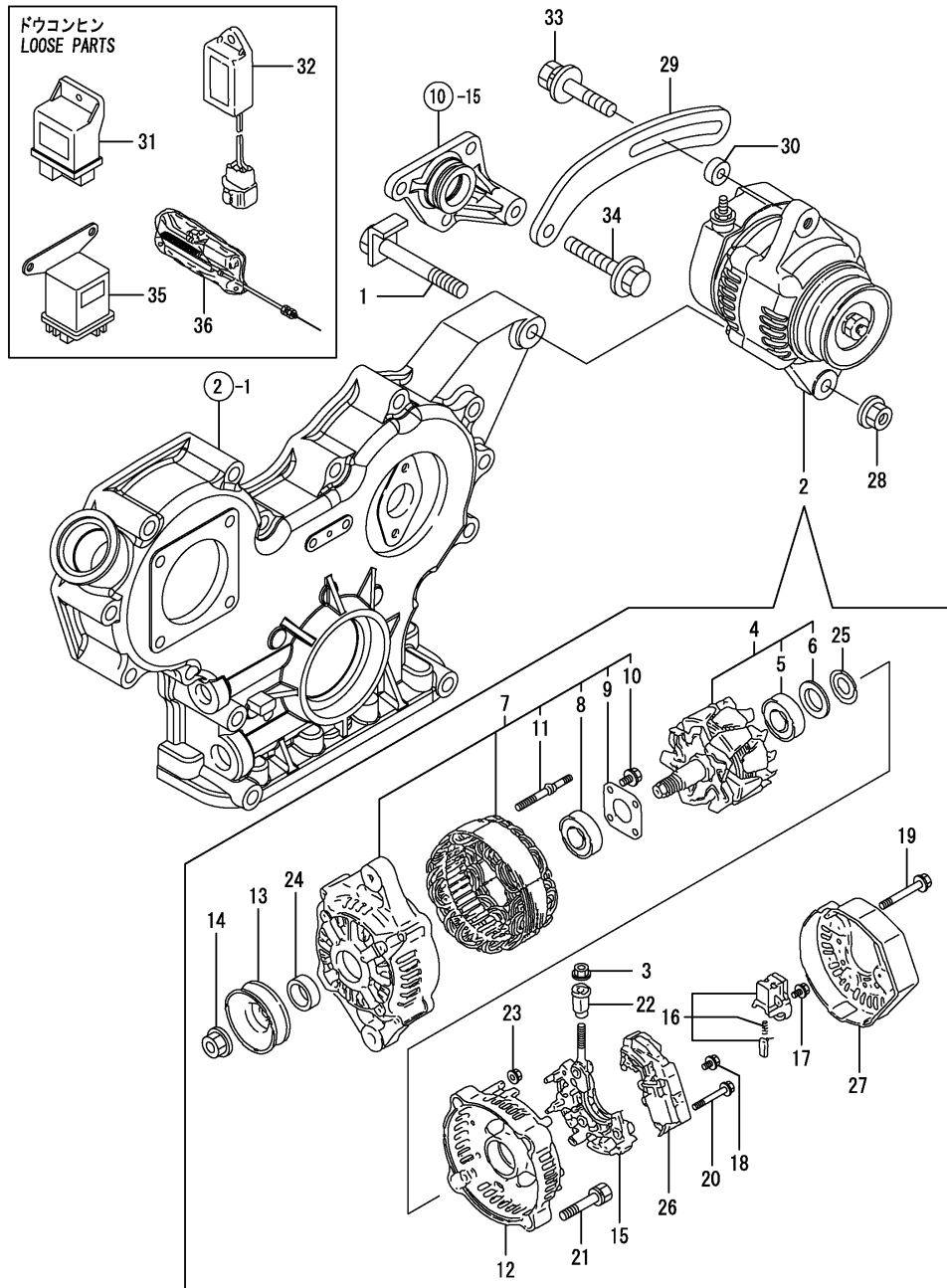

(A)=3TNV88-QTBC

(B)=

(C)=

(D)=

(E)=

(F)=

No.	Lev.	Parts No.	Description	Q'ty						I	R
				(A)	(B)	(C)	(D)	(E)	(F)		
1	1	119740-77250	BOLT, M10X76	1							
2	1	129240-77200	ALTERNATOR	1							
3	2	129240-79310	NUT	1							
4	2	119620-77380	ROTOR ASSY	1							
5	3	126501-79240	BALL BEARING	1							
6	3	119620-79250	COVER, BEARING	1							
7	2	119620-77421	FRAME ASSY, DRIVE	1							
8	3	119620-79200	BALL BEARING	1							
9	3	119620-79210	PLATE	1							
10	3	119620-79220	SCREW	4							
11	3	119620-79230	BOLT, STUD	2							
12	2	119620-77440	FLAME ASSY, REAR	1							
13	2	119620-77461	PULLEY	1							
14	2	119620-77471	NUT	1							
15	2	119620-79260	HOLDER	1							
16	2	129052-79270	HOLDER, BRUSH	1							
17	2	119620-79290	SCREW	6							
18	2	119620-79300	SCREW	1							
19	2	119620-79310	BOLT	3							
20	2	119620-79320	SCREW W/WASHER	2							
21	2	119620-79330	BOLT	2							
22	2	119620-79340	INSULATION BUSH	1							
23	2	119620-79350	NUT	2							
24	2	119620-77490	COLLAR	1							
25	2	119620-79360	WASHER, THRUST	1							
26	2	129240-77710	REGULATOR ASSY	1							
27	2	129240-79300	COVER	1							
28	1	26306-100002	NUT, M10	1							
29	1	119802-77330	ADJUSTER	1							
30	1	119940-77270	SPACER, GENERATOR	1							
31	1	119802-77200	RELAY, SAFETY	1							
32	1	129211-77920	TIMER	1							
33	1	129972-77341	BOLT, ADJUSTER L=50	1							
34	1	26106-080452	BOLT, M8X 45 PLATED	1							
35	1	119646-77900	RELAY, POWER	3							
36	1	119032-77910	MOTOR ASSY	1							

Fig.17. TOOLS & GASKET SET

(A)=3TNV88-QTBC

(B)=

(C)=

(D)=

(E)=

(F)=

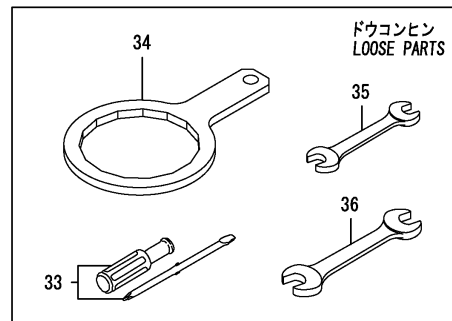
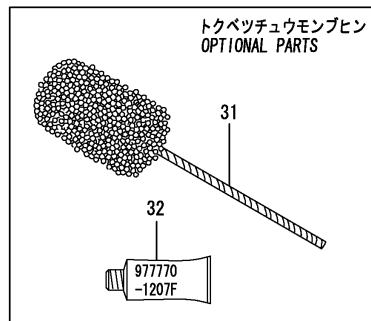
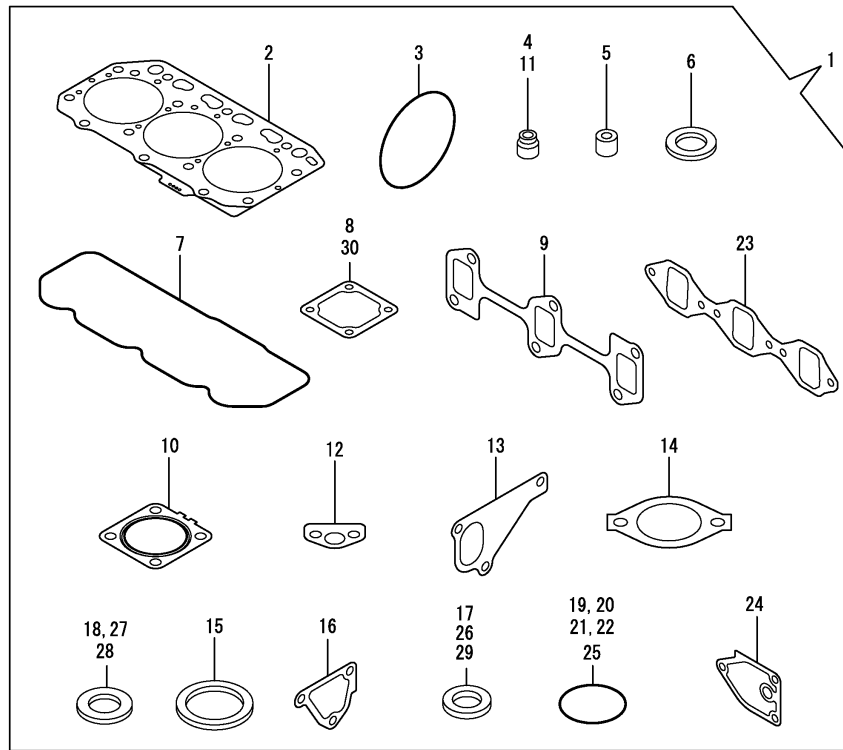

No.	Lev.	Parts No.	Description	Q'ty						I	R
				(A)	(B)	(C)	(D)	(E)	(F)		
1	1	729001-92990	GASKET SET	1							1
2	2	129001-01340	GASKET, HEAD	1							
3	2	121850-51960	O-RING	1							
4	2	124460-11340	SEAL, VALVE STEM	3							
5	2	119802-11870	PROTECTOR, NOZZLE	3							
6	2	119625-11880	SEAT, NOZZLE	3							
7	2	129004-11310	GASKET, BONNET	1							
8	2	129150-77511	GASKET	1							
9	2	129150-13110	GASKET	1							
10	2	129004-13200	GASKET, SILENCER	1							
11	2	121400-11340	SEAL, VALVE STEM	3							
12	2	129150-35042	GASKET	1							
13	2	129486-42021	GASKET, WATER PUMP	1							
14	2	129795-49551	GASKET	1							
15	2	129150-49811	GASKET, THERMOSTAT	1							
16	2	124395-49840	GASKET	1							
17	2	22190-080002	WASHER, SEAL 6	2							
18	2	124465-44950	GASKET, 16	1							
19	2	24311-000120	O-RING, 1AP12.0	3							
20	2	24311-000320	O-RING, 1AP32.0	2							
21	2	24341-000240	O-RING, 1AS24.0	1							
22	2	129486-42140	O-RING, G30	1							
23	2	129150-12111	GASKET, MANIFOLD	1							
24	2	129150-35111	GASKET	1							
25	2	119609-32040	O-RING, P16	4							
26	2	22190-100002	WASHER, SEAL 10	2							
27	2	23414-080000	GASKET, 8X1.0	1							
28	2	129150-49360	GASKET	1							
29	2	22190-220002	WASHER, SEAL 22	1							
30	2	129100-77510	GASKET, AIR HEATER	1							
31	1	129400-92430	HONE	1							1
32	1	977770-1207F	GASKET, LIQUID	1							1
33	1	104200-92350	DRIVER, SCREW	1							
34	1	119640-92750	WRENCH, FILTER 80	1							
35	1	28110-100120	SPANNER, 10X12	1							
36	1	28110-140170	SPANNER, 14X17	1							

Remarks

(1) OPTIONAL PARTS.

Parts No. Index

Parts No.	Fig. No.	Ref. No.
104200-92350	17	33
105025-59580	14	11
114250-39450	9	25
114250-53080	13	5
114250-53120	13	10
114250-53130	13	11
114250-53140	13	12
114250-53210	13	13
114250-53400	13	14
119005-35151	9	12
119032-77910	16	36
119131-18320	6	3
119140-12680	5	22
119233-77932	12	96
119255-44660	10	57
119266-49350	10	31
119305-59120	13	26
119593-59581	13	56
119609-32040	2	17
	17	25
119620-01750	3	3
119620-77380	16	4
119620-77421	16	7
119620-77440	16	12
119620-77461	16	13
119620-77471	16	14
119620-77490	16	24
119620-79200	16	8
119620-79210	16	9
119620-79220	16	10
119620-79230	16	11
119620-79250	16	6
119620-79260	16	15
119620-79290	16	17
119620-79300	16	18
119620-79310	16	19
119620-79320	16	20
119620-79330	16	21
119620-79340	16	22
119620-79350	16	23
119620-79360	16	25
119625-11880	4	32
	17	6
119640-01640	3	9
119640-92750	17	34
119646-77900	16	35
119660-61901	12	59
119740-77250	16	1
119802-01520	2	12
119802-01561	2	13

Parts No.	Fig. No.	Ref. No.
119802-03110	4	43
119802-03121	4	44
119802-03130	4	45
119802-03141	4	46
119802-11260	4	6
119802-11270	4	7
119802-11280	4	8
119802-11870	4	55
	17	5
119802-21202	8	5
119802-25051	7	10
119802-25071	7	14
119802-25101	7	11
119802-25901	7	17
119802-32070	2	8
119802-32100	2	7
119802-32111	2	18
119802-32120	2	19
119802-32130	2	20
119802-35110	9	9
119802-39450	9	27
119802-49113	10	10
119802-49730	10	37
119802-51090	11	89
119802-51250	11	132
119802-51560	11	52
119802-51590	11	58
119802-51600	11	59
119802-51680	11	63
119802-51690	11	64
119802-55710	14	15
119802-59550	13	50
119802-77200	16	31
119802-77330	16	29
119807-61420	12	22
119808-12540	5	19
119865-21600	8	16
119866-12541	5	20
119934-01800	2	6
119940-55690	14	12
119940-77270	16	30
120130-11860	4	19
120270-54410	4	34
121023-01551	2	28
121111-21501	8	12
121120-13590	6	12
121250-44901	10	32
121256-44600	10	52
121400-11340	4	28
	17	11

Parts No.	Fig. No.	Ref. No.
121450-44531	10	47
121470-44581	10	49
121520-34810	9	2
121550-23200	8	30
121550-49111	10	43
121850-21680	8	11
121850-42410	10	8
121850-51960	2	21
	17	3
123900-13610	6	5
123900-13630	6	4
124060-01050	1	5
124060-77680	13	57
124160-01751	2	14
	4	39
124160-01910	1	7
		8
124160-11360	4	52
124160-39140	9	26
124240-01871	2	15
124395-49840	10	17
	17	16
124450-44550	10	51
124450-44560	10	48
124460-11340	4	29
	17	4
124465-44950	10	33
	17	18
124550-77030	15	33
124722-59050	10	38
		41
	13	51
		54
124766-59050	14	5
		9
126501-79240	16	5
129001-01250	1	6
129001-01340	1	33
	17	2
129001-02931	1	25
129001-32330	2	11
129001-91841	2	22
129002-21590	8	13
129004-01190	1	31
129004-03010	4	41
129004-11130	4	24
129004-11241	4	3
129004-11251	4	4
129004-11310	4	49
	17	7

Parts No.	Fig. No.	Ref. No.
129004-11350	4	40
129004-11650	4	10
129004-11700	4	15
129004-11900	4	33
129004-13129	6	1
129004-13200	6	7
	17	10
129004-21002	8	1
129004-21650	8	9
129004-42001	10	1
129004-42040	10	15
129004-49610	10	35
129004-49620	10	39
129004-49711	10	36
129004-49721	10	40
129004-53001	13	2
129004-55612	14	1
129005-22080	8	17
129005-22500	8	19
129005-22900	8	35
129005-22950	8	37
129005-34802	9	1
129005-59830	9	28
129006-35100	9	8
129006-44480	9	13
129006-49040	9	18
129030-12201	5	15
129030-44760	10	23
129044-59010	14	4
129044-59100	14	6
129044-59510	14	7
129052-79270	16	16
129100-01580	3	1
		15
	8	2
129100-01640	3	16
129100-01730	3	6
129100-11112	4	25
129100-23910	8	29
129100-42051	10	3
129100-42121	10	4
129100-55690	14	16
129100-77500	5	9
129100-77510	5	10
	17	30
129103-49301	9	23
129107-44590	10	64
129129-14580	7	3
129136-77011	15	1
129136-77310	15	2

Parts No. Index

Parts No.	Fig. No.	Ref. No.
129136-77520	15	14
129150-01200	1	32
129150-02020	1	10
129150-02450	7	4
129150-02871	1	34
129150-02931	1	28
129150-02941	1	37
129150-03070	4	42
129150-11230	4	11
129150-11280	4	9
129150-11370	4	14
129150-11750	4	13
129150-11810	4	21
129150-12111	5	6
	17	23
129150-13110	6	2
	17	9
129150-14101	7	7
129150-14200	7	1
129150-14400	7	2
129150-23601	8	31
129150-23611	8	33
129150-25301	7	16
129150-35042	9	3
	17	12
129150-35091	9	4
129150-35111	9	11
	17	24
129150-49080	10	59
129150-49100	10	58
129150-49360	10	34
	17	28
129150-49811	10	26
	17	15
129150-59120	13	30
129150-59131	13	29
		33
129150-77511	5	11
	17	8
129155-42350	10	20
129155-51280	12	5
129155-61460	12	24
129202-22300	8	23
129211-77920	16	32
129240-77200	16	2
129240-77710	16	26
129240-79300	16	27
129240-79310	16	3
129242-12500	5	17
129242-13510	6	8

Parts No.	Fig. No.	Ref. No.
129242-13650	6	9
129242-49010	10	53
129255-61410	12	21
129259-12570	5	21
129263-03080	5	1
129263-12100	5	3
129263-12210	5	5
129263-59550	13	48
129263-59810	13	35
129263-59820	13	39
129263-59830	13	43
129335-44740	10	22
129350-49530	10	27
129400-77490	15	12
129400-77571	15	18
129400-92430	17	31
129410-03990	5	2
129417-33110	9	37
129417-35150	9	10
129418-32320	2	10
129457-49801	10	25
129467-44580	10	65
129467-44590	10	66
129486-01670	3	19
129486-42021	10	14
	17	13
129486-42140	10	16
	17	22
129486-59320	13	49
129486-59551	13	53
129508-33010	9	35
129508-33050	9	36
129508-49030	9	14
129612-01600	3	2
129612-42290	10	21
129612-49040	10	54
129612-52100	14	13
129642-44520	10	63
129642-49180	9	19
129642-61060	12	97
129795-01780	3	18
129795-01950	2	16
129795-02412	1	13
129795-11120	4	26
129795-11180	4	27
129795-21661	8	10
129795-49551	10	28
	17	14
129900-07900	4	1
129900-32130	2	9

Parts No.	Fig. No.	Ref. No.
129900-77400	15	3
129900-77440	15	6
129900-77450	15	7
		11
129900-77460	15	9
129900-77480	15	10
129900-77640	15	19
129904-12520	5	18
129906-55700	14	14
129907-55801	14	2
129916-49740	10	13
129916-59020	11	130
129950-59311	14	8
129961-59110	14	10
129972-77341	16	33
158552-51151	7	18
158552-51570	11	53
		54
158552-51580	11	57
158552-51600	11	67
158552-51670	11	4
158552-51780	11	123
158552-52100	11	79
158552-52310	11	81
158552-52400	11	93
158552-52500	11	80
158552-61441	12	23
158552-61900	12	82
158553-51551	11	50
158553-51630	11	68
158553-51640	11	70
158553-51660	11	72
158553-51670	11	62
158553-51680	11	73
158553-51770	11	97
158553-61050	12	2
158553-61070	12	3
158557-51570	11	55
158560-51300	11	38
158563-51281	11	36
		37
158563-51330	11	46
158600-51270	11	35
158601-51340	11	47
158601-51550	11	51
158601-51570	11	56
158601-51650	11	71
158601-51770	11	122
158601-51790	11	124
171008-03990	9	15

Parts No.	Fig. No.	Ref. No.
171008-77450	15	8
171008-77510	15	13
171008-77540	15	15
171008-77650	15	20
171008-77660	15	24
171008-77670	15	25
171008-77750	15	31
171051-01921	1	9
171064-44510	10	45
171340-77520	5	12
22117-100000	6	14
22190-080002	9	30
		31
	17	17
22190-100002	9	32
	17	26
22190-120000	12	63
22190-120002	11	82
		83
		125
22190-180002	11	84
		126
22190-220002	3	11
	17	29
22217-100000	6	15
22217-140000	7	19
	11	85
22252-000260	8	24
22312-050140	11	86
22351-030010	8	8
22351-050010	11	87
22351-060012	4	35
22512-070140	7	8
	8	6
22857-500100	4	50
		51
23000-060000	5	16
23010-038000	10	55
23010-044000	10	56
23065-070225	10	50
23080-015000	9	17
		21
23080-018000	9	22
23414-080000	10	30
	17	27
23857-030000	9	29
23857-060000	11	90
23876-010000	10	11
23876-020000	10	12
23876-030000	2	4

Parts No. Index

Parts No.	Fig. No.	Ref. No.
23876-040000	2	5
23887-120002	11	127
	12	65
24311-000070	11	92
24311-000120	4	53
	17	19
24311-000160	14	18
24311-000320	2	23
	4	54
	17	20
24321-000650	14	17
24341-000240	2	29
	17	21
24356-010180	11	94
24356-010200	11	65
		95
24372-000150	11	66
26106-060102	11	96
	12	53
		67
26106-060142	12	83
		84
26106-060162	2	30
26106-060202	12	85
26106-060322	15	29
26106-060402	15	30
26106-060502	10	24
26106-080122	10	42
26106-080142	7	9
26106-080162	2	24
		25
	3	12
	4	2
	10	18
	11	133
26106-080202	9	24
	11	134
26106-080222	10	29
26106-080252	3	13
	4	36
	5	7
	14	19
26106-080302	14	3
26106-080352	3	20
	4	37
	9	34
26106-080402	5	13
	7	15
26106-080452	3	14
	14	-1

Parts No.	Fig. No.	Ref. No.
26106-080452	10	44
	16	34
26106-080502	3	22
	4	38
26106-080552	2	26
26106-080602	10	19
26106-080702	5	8
26106-080802	5	14
26106-100202	6	10
26106-100652	6	16
26116-120252	15	32
26206-100252	3	4
26206-100302	3	5
26306-080002	2	27
	6	6
		11
26306-100002	16	28
26366-060002	9	33
26450-080452	11	101
26706-100002	6	17
26756-060002	12	68
26776-140002	7	20
	11	102
27241-120000	1	14
27241-300000	1	15
27241-400000	4	23
27310-080001	4	30
28110-100120	17	35
28110-140170	17	36
729001-92990	17	1
729005-01562	1	1
729102-01540	3	8
729240-01500	2	1
729242-51400	11	1
729245-53100	13	1
729402-23100	8	25
977770-1207F	2	31
	3	21
	4	56
	17	32
X2114255110	15	5
X2114555500	15	21
X2114955020	15	22
X2130350900	15	4
X2240410100	15	23

Parts No.	Fig. No.	Ref. No.
-----------	----------	----------

Parts No.	Fig. No.	Ref. No.
-----------	----------	----------