

OCD10-M85401EN

PREFACE

1. This parts catalog is the 2nd edition of 3TNV70-QIK for IHI Construction Machinery Limited.

Pub.No. : 000Y00D8541

Published : November,2006

2.Model name

Engine model	Vehicle		Vehicle made by
	Products	Model name	
3TNV70-QIK	Excavator	15NX2	IHI Construction Machinery Ltd.

Contents

Fig. No. Fig. Name

3TNV70-QIK

1. CYLINDER BLOCK
2. GEAR HOUSING
3. FLYWHEEL HOUSING & OIL SUMP
4. CYLINDER HEAD & BONNET
5. AIR CLEANER
6. EXHAUST MANIFOLD & SILENCER
7. CAMSHAFT & DRIVING GEAR
8. CRANKSHAFT & PISTON
9. LUB.OIL SYSTEM
10. COOLING WATER SYSTEM
11. FUEL INJECTION PUMP
12. GOVERNOR
13. FUEL INJECTION VALVE
14. FUEL LINE
18. (14A)FUEL LINE
15. STARTING MOTOR
16. GENERATOR
17. GASKET SET

Fig. No. Fig. Name

Fig.1. CYLINDER BLOCK

(A)=3TNV70-QIK

(B)=

(C)=

(D)=

(E)=

(F)=

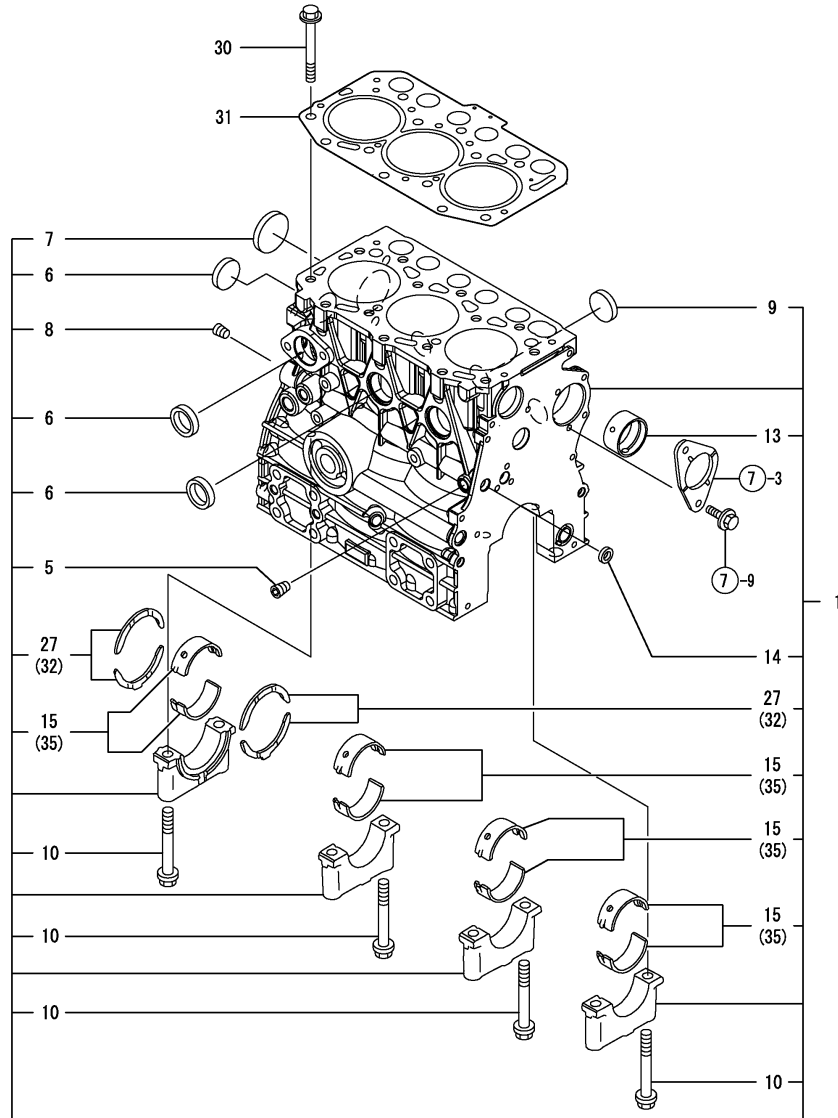

No.	Lev.	Parts No.	Description	Q'ty						I	R
				(A)	(B)	(C)	(D)	(E)	(F)		
1	1	719515-01560	BLOCK ASSY, CYLINDER	1							
5	2	124060-01050	PLUG, PT1/8	1							
6	2	105311-01090	PLUG, 30	4							
7	2	119623-01250	PLUG, 45	1							
8	2	124160-01910	PLUG, PT1/4	1							
9	2	119285-01990	PLUG, 25	3							
10	2	119620-02020	BOLT, METAL CAP	8							
13	2	119717-02410	BUSH, CAMSHAFT	1							
13-1	2	119717-02411	BUSH, CAMSHAFT	1							N
(A=E09945)											
14	2	27241-120000	PLUG, 12	1							
15	2	719717-02900	BEARING, MAIN	4							2
15-1	2	719717-02901	BEARING, MAIN	4							N 2
(A=E09945)											
27	2	119717-02930	BEARING, THRUST	2							
30	1	119515-01200	BOLT, HEAD	14							
31	1	119515-01330	GASKET, HEAD	1							
32	1	119810-02940	BEARING, THRUST 0.25	2							1
32-1	1	119810-02941	BEARING, THRUST 0.25	2							N 1
(A=E09945)											
35	1	719717-02910	BEARING, 0.25 US	4							3
35-1	1	719717-02911	BEARING, 0.25 US	4							N 3
(A=E09945)											

Remarks
 (1) OVER-SIZE(O.S=0.25)PART.
 (2) REPAIR PART.
 (3) UNDER-SIZE(U.S=0.25)PART.

Fig.2. GEAR HOUSING

(A)=3TNV70-QIK

(B)=

(C)=

(D)=

(E)=

(F)=

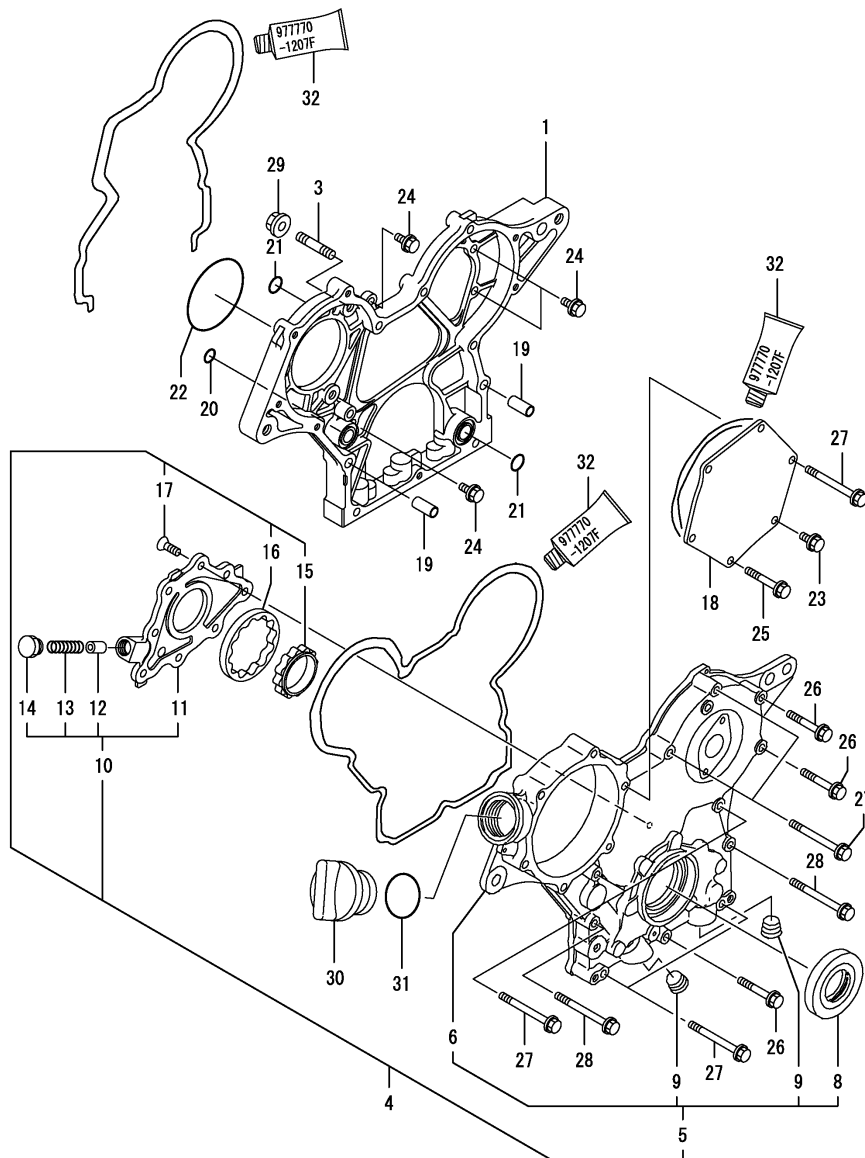

No.	Lev.	Parts No.	Description	Q'ty						I	R
				(A)	(B)	(C)	(D)	(E)	(F)		
1	1	119717-01501	CASE, GEAR	1							
3	1	119717-01570	STUD	3							
4	1	119717-01590	COVER ASSY,GEAR CASE	1							
5	2	719717-01500	COVER ASSY,GEAR CASE	1							
6	3	119717-01521	COVER, GEAR CASE	1							
8	3	119620-01800	SEAL, OIL	1							
9	3	23876-030000	PLUG, R03	2							
10	2	119717-32100	COVER ASSY	1							
11	3	119717-32080	COVER	1							
12	3	129900-32130	VALVE, RELIEF	1							
13	3	129001-32320	SPRING	1							
14	3	129001-32330	PLUG	1							
15	2	119717-32110	ROTOR, INNER	1							
16	2	119717-32120	ROTOR, OUTER	1							
17	2	119802-32130	SCREW, M6X16	8							
18	1	119717-01750	COVER	1							
19	1	119660-01911	PIPE, KNOCK	4							
20	1	119624-32040	O-RING, P12.0	1							
21	1	119717-32050	O-RING, P17.0	3							
22	1	121850-51960	O-RING	1							
23	1	26106-060122	BOLT, M6X 12 PLATED	1							
24	1	26106-060162	BOLT, M6X 16 PLATED	4							
25	1	26106-060402	BOLT, M6X 40 PLATED	4							
26	1	26106-060402	BOLT, M6X 40 PLATED	3							
27	1	26106-060602	BOLT, M6X 60 PLATED	7							
28	1	26106-060652	BOLT, M6X 65 PLATED	2							
29	1	26306-080002	NUT, M8	3							
30	1	124160-01751	COVER, FILLER	1							
31	1	24311-000320	O-RING, 1AP32.0	1							
32	1	977770-1207F	GASKET.LIQUID	1							1

Remarks
(1) OPTIONAL PART.

Fig.3. FLYWHEEL HOUSING & OIL SUMP

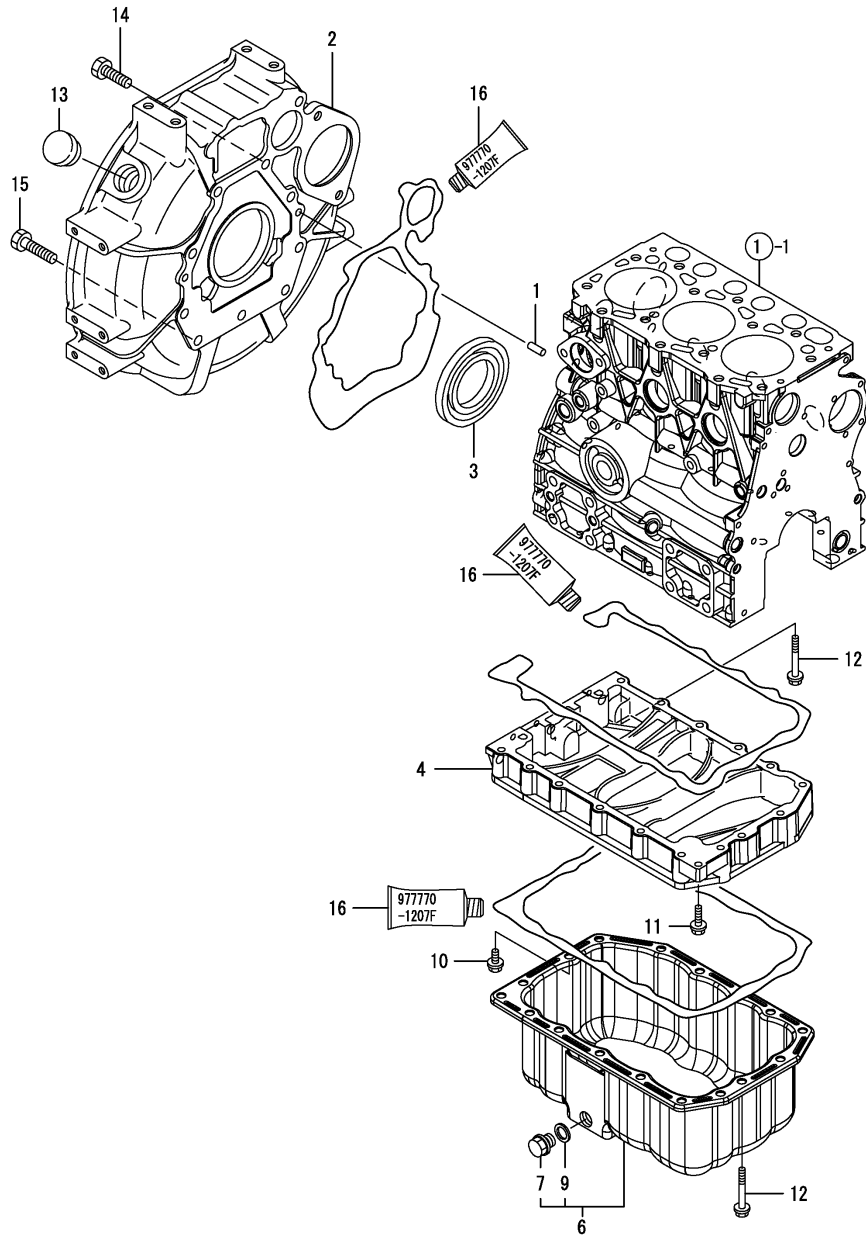

(A)=3TNV70-QIK

(B)=

(C)=

(D)=

(E)=

(F)=

No.	Lev.	Parts No.	Description	Q'ty						I	R
				(A)	(B)	(C)	(D)	(E)	(F)		
1	1	129100-01580	PIN, M8X16	2							
2	1	119515-01601	HOUSING, FLYWHEEL	1							
3	1	124085-02220	SEAL, OIL	1							
4	1	119515-01720	SPACER, OIL SUMP	1							
6	1	119546-01770	SUMP ASSY, OIL	1							
7	2	105425-01690	PLUG, 16	1							
9	2	22190-160002	WASHER, SEAL 16	1							
10	1	26106-060122	BOLT, M6X 12 PLATED	1							
11	1	26106-060252	BOLT, M6X 25 PLATED	1							
12	1	26106-060452	BOLT, M6X 45 PLATED	17							
13	1	119620-01750	CAP	1							
14	1	26206-100252	BOLT, M10X 25 PLATED	7							
15	1	121120-01620	BOLT, M10X28	3							
16	1	977770-1207F	GASKET.LIQUID	1							1

Remarks
(1) OPTIONAL PART.

Fig.4. CYLINDER HEAD & BONNET

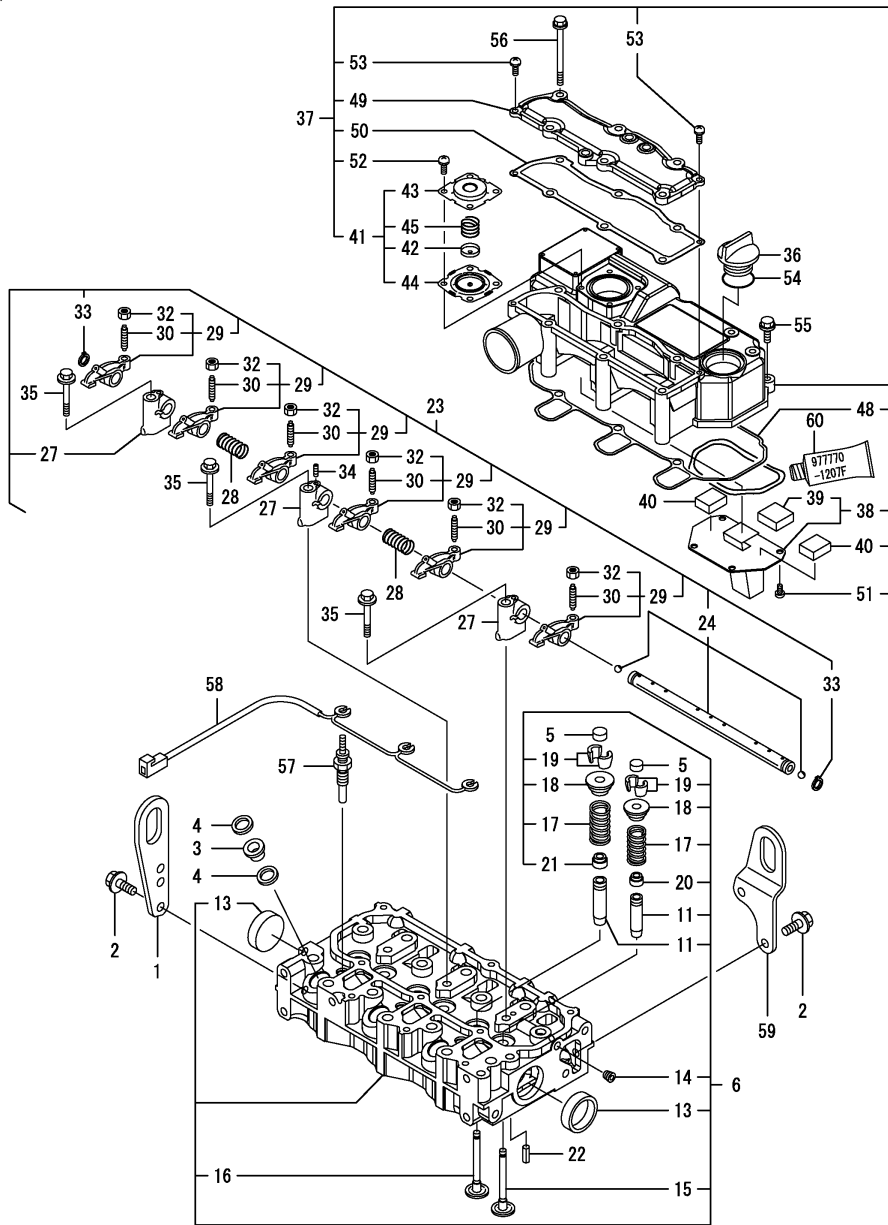

Remarks
 (1) REPAIR PART.
 (2) OPTIONAL PART.

(A)=3TNV70-QIK

(B)=

(C)=

(D)=

(E)=

(F)=

No.	Lev.	Parts No.	Description	Q'ty						I	R
				(A)	(B)	(C)	(D)	(E)	(F)		
1	1	119226-07900	LIFTER	1							
2	1	26106-080162	BOLT, M8X 16 PLATED	4							
3	1	129901-11450	PROTECTOR, NOZZLE	3							
4	1	119600-11460	GASKET, NOZZLE	6							
5	1	105010-11490	CAP, VALVE	6							
6	1	119515-11740	HEAD ASSY, CYLINDER	1							
11	2	119515-11800	GUIDE, VALVE	6							1
13	2	119285-11990	PLUG, 35	2							
14	2	23876-005000	PLUG, R005	1							
15	2	119515-11100	VALVE, INTAKE	3							
15-1	2	119515-11101	VALVE, INTAKE	3							R
(A=E114618)											
16	2	119515-11110	VALVE, EXHAUST	3							
17	2	119717-11131	SPRING, VALVE	6							
18	2	129508-11180	RETAINER, SPRING	6							
19	2	119717-11190	COTTER	12							
20	2	119717-11340	SEAL, VALVE STEM	3							
21	2	119717-11350	SEAL, VALVE STEM	3							
22	1	22351-060012	PIN, SPRING 6.0X12	2							
23	1	119515-11200	SUPPORT ASSY, ARM	1							
24	2	119515-11240	SHAFT ASSY, ROCKER	1							
27	2	119717-11260	SUPPORT, ROCKER ARM	3							
28	2	119515-11280	SPRING	2							
29	2	119717-11650	ARM, ROCKER	6							
30	3	129150-11230	SCREW, VALVE ADJUST	6							
32	3	129150-11750	NUT, M8	6							
33	2	22242-000120	RING, 12	2							
34	2	26979-050162	SCREW, M5X16	1							
35	1	26106-080402	BOLT, M8X 40 PLATED	3							
36	1	124160-01751	COVER, FILLER	1							
37	1	119515-11380	BONNET ASSY, HEAD	1							
38	2	119717-03031	PLATE	1							
39	3	119717-03070	BAFFLE, BREATHER	1							
40	2	119717-03070	BAFFLE, BREATHER	2							
41	2	119802-03100	DIAPHRAGM ASSY	1							
42	3	119802-03110	PLATE	1							
43	3	119802-03121	COVER, DIAPHRAGM	1							
44	3	119802-03131	DIAPHRAGM	1							
45	3	119802-03141	SPRING, DIAPHRAGM	1							
48	2	119515-11310	GASKET, BONNET	1							
49	2	119515-11320	COVER, BONNET	1							
50	2	119515-11330	GASKET	1							
51	2	22857-500100	SCREW, 5X10	4							
52	2	22857-500100	SCREW, 5X10	4							
53	2	22857-500160	SCREW, 5X16	2							
54	1	24311-000320	O-RING, 1AP32.0	1							
55	1	26106-060202	BOLT, M6X 20 PLATED	3							
56	1	26106-060752	BOLT, M6X 75 PLATED	6							
57	1	119717-77800	PLUG, GLOW	3							
58	1	119717-77820	CONNECTOR, GLOW PLUG	1							
59	1	119540-07910	LIFTER	1							

Fig.4. CYLINDER HEAD & BONNET

(A)=3TNV70-QIK

(B)=

(C)=

(D)=

(E)=

(F)=

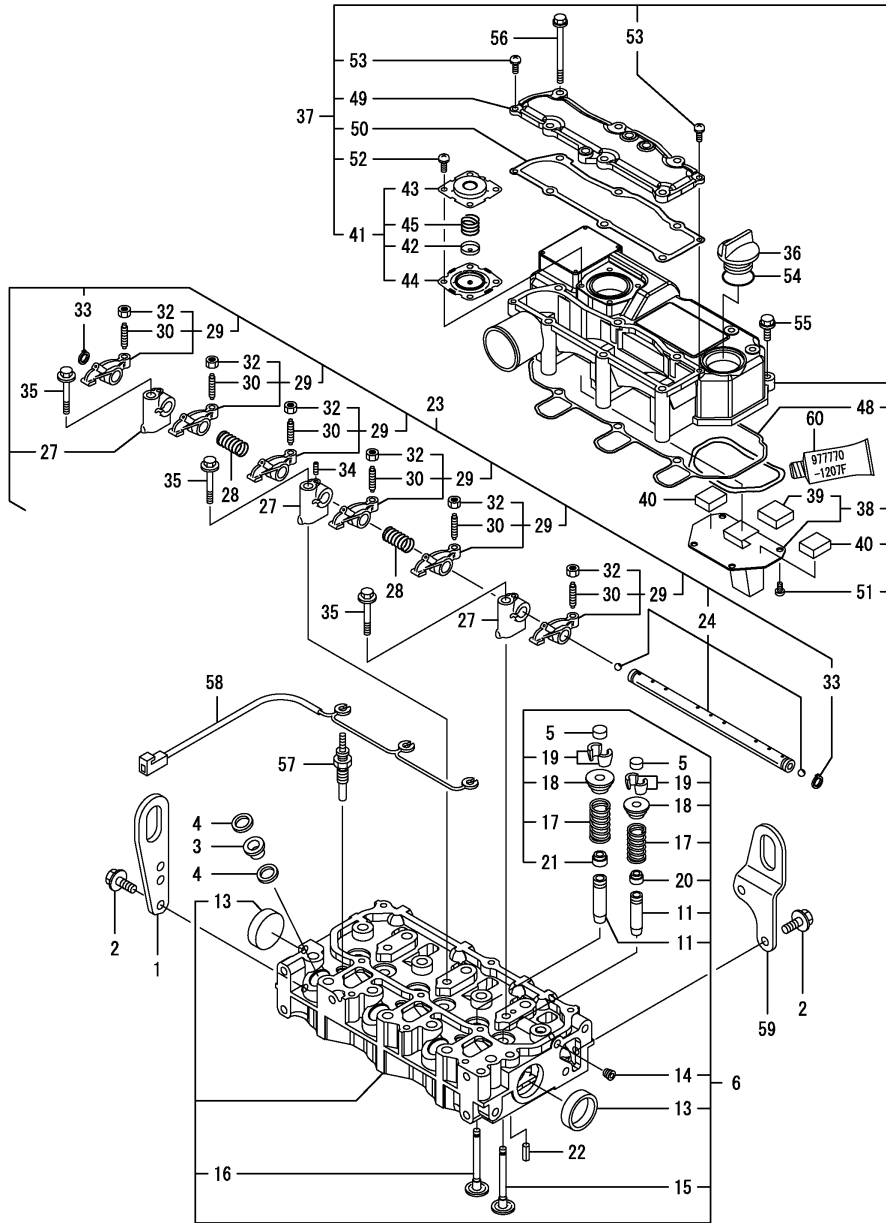

No.	Lev.	Parts No.	Description	Q'ty						I	R
				(A)	(B)	(C)	(D)	(E)	(F)		
60	1	97770-1207F	GASKET.LIQUID	1							2

Remarks
 (1) REPAIR PART.
 (2) OPTIONAL PART.

Fig.5. AIR CLEANER

(A)=3TNV70-QIK
 (B)=
 (C)=

(D)=
 (E)=
 (F)=

No.	Lev.	Parts No.	Description	Qty						I	R
				(A)	(B)	(C)	(D)	(E)	(F)		
1	1	119515-12610	CLEANER ASSY, AIR	1							
2	2	119515-12520	ELEMENT	1							
3	2	119808-12540	VALVE, UNLOADER	1							
4	2	119655-12570	COVER ASSY	1							
5	2	105027-12580	RING	1							
6	2	129612-12650	LABEL, MARKING	1							
7	2	126650-12680	INDICATOR	1							
8	2	119233-12700	ELEMENT	1							

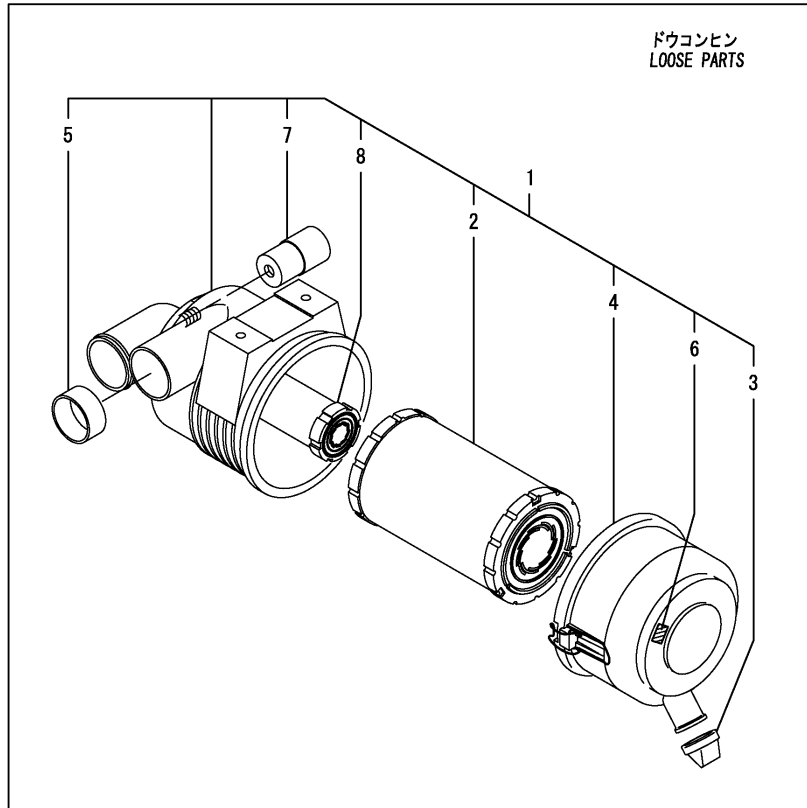

Fig.6. EXHAUST MANIFOLD & SILENCER

(A)=3TNV70-QIK

(B)=

(C)=

(D)=

(E)=

(F)=

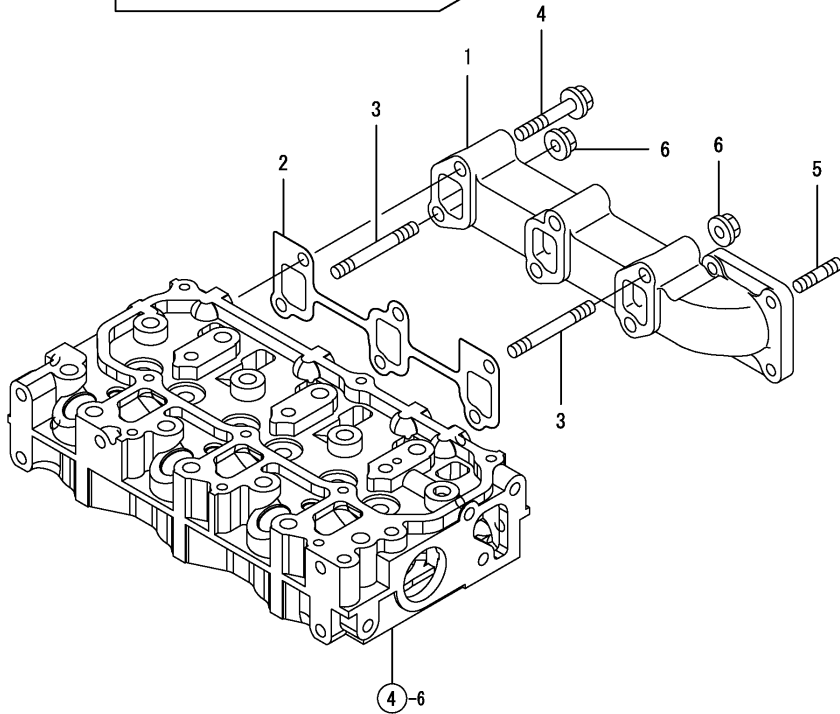
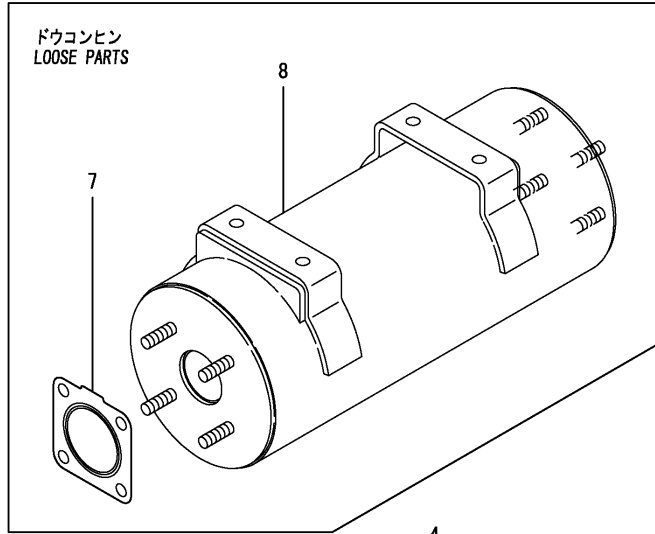

No.	Lev.	Parts No.	Description	Q'ty						I	R
				(A)	(B)	(C)	(D)	(E)	(F)		
1	1	119540-13100	MANIFOLD, EXHAUST	1							
2	1	119717-13110	GASKET	1							
3	1	119717-13600	STUD, M8X50	2							
4	1	119802-13620	BOLT, M8X50	4							
5	1	119131-18320	STUD, M8X22	4							
6	1	26306-080002	NUT, M8	2							
7	1	119515-13200	GASKET, SILENCER	3							
8	1	119515-13530	SILENCER	1							

Fig.7. CAMSHAFT & DRIVING GEAR

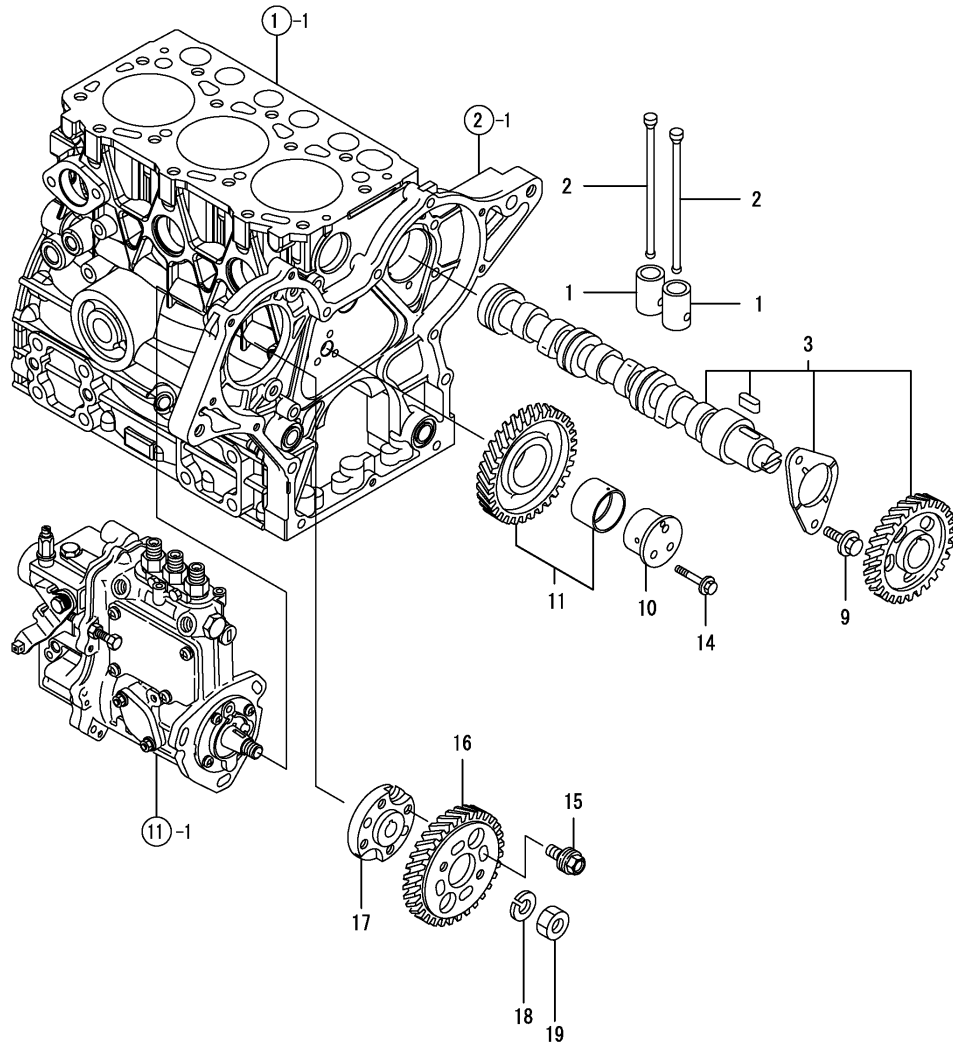

(A)=3TNV70-QIK

(B)=

(C)=

(D)=

(E)=

(F)=

No.	Lev.	Parts No.	Description	Q'ty						I	R
				(A)	(B)	(C)	(D)	(E)	(F)		
1	1	119620-14200	TAPPET	6							
2	1	119515-14400	ROD, PUSH	6							
3	1	119515-14580	CAMSHAFT ASSY	1							
3-1	1	119515-14581 (A=E09275)	CAMSHAFT ASSY	1							R
9	1	26106-060122	BOLT, M6X 12 PLATED	2							
10	1	119717-25050	SHAFT, IDLE	1							
11	1	119717-25100	GEAR ASSY, IDLE	1							
11-1	1	119717-25101 (A=E09945)	GEAR ASSY, IDLE	1							N
14	1	26106-060352	BOLT, M6X 35 PLATED	3							
15	1	129150-25301	BOLT	4							
16	1	119717-25930	GEAR, PUMP	1							
17	1	119717-51150	FLANGE	1							
18	1	22217-120000	WASHER, SPRING 12	1							
19	1	26716-120002	NUT, M12	1							

Fig.8. CRANKSHAFT & PISTON

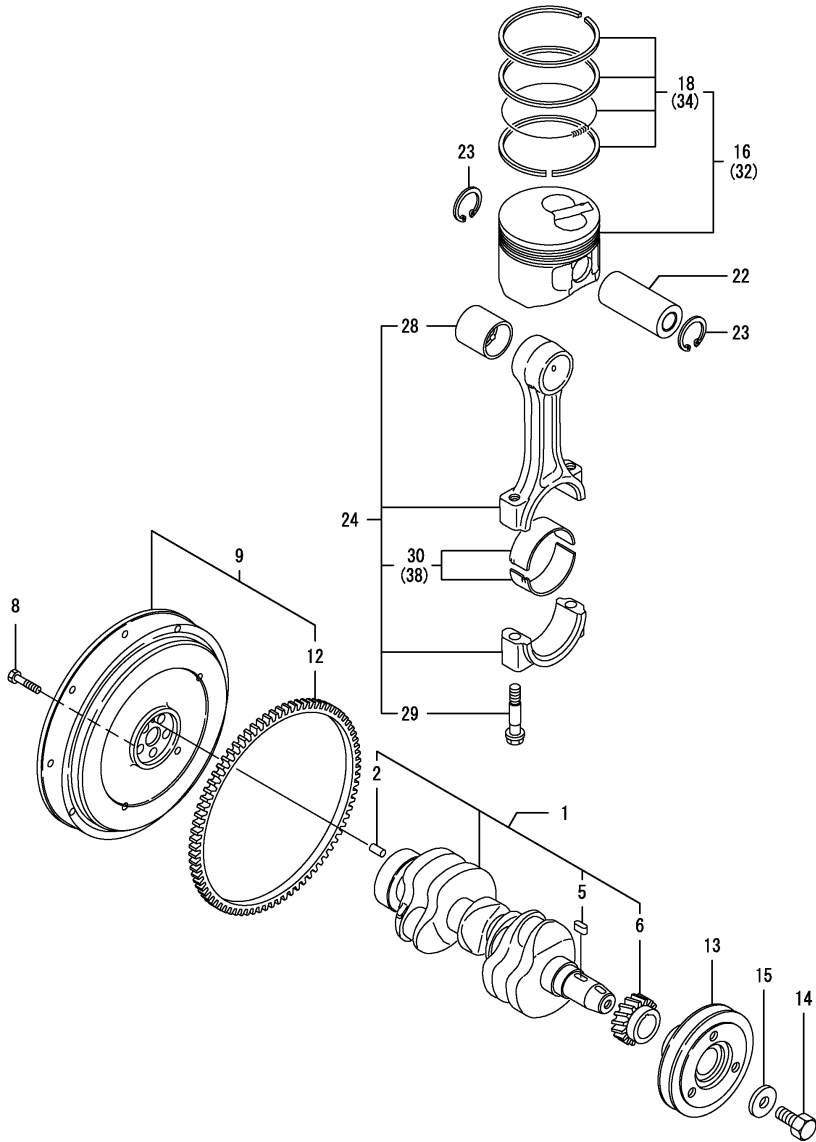

(A)=3TNV70-QIK

(B)=

(C)=

(D)=

(E)=

(F)=

No.	Lev.	Parts No.	Description	Q'ty						I	R
				(A)	(B)	(C)	(D)	(E)	(F)		
1	1	119515-21700	CRANKSHAFT ASSY	1							
2	2	129100-01580	PIN, M8X16	1							
5	2	22512-040120	KEY, 4X 12	1							
6	2	119717-21200	GEAR, CRANKSHAFT	1							
8	1	119620-21500	BOLT, FLYWHEEL	5							
9	1	119515-21580	FLYWHEEL ASSY	1							
12	2	124950-21600	GEAR, RING	1							
13	1	119717-21650	V-PULLEY	1							
14	1	119621-21680	BOLT, FLANGE 12X1.25	1							
15	1	119620-21941	WASHER	1							
16	1	119515-22080	PISTON ASSY	3							
18	2	119515-22500	RING SET, PISTON	3							
22	1	119515-22300	PIN, PISTON	3							
23	1	22252-000220	RING, 22	6							
24	1	119515-23000	ROD ASSY, CONNECTING	3							
28	2	119717-23910	BEARING, PISTON PIN	3							2
29	2	119717-23200	BOLT, CONNECTING ROD	6							
30	2	119515-23600	BEARING, CRANK PIN	3							
30-1	2	119515-23601	BEARING, CRANK PIN	3							N
		(A=E09945)									
31-1	3	119515-23301	BEARING, CRANK PIN	6							N
		(A=E09945)									
32	1	119515-22900	PISTON ASSY, 0.25 OS	3							1
34	2	119515-22550	RING SET, 0.25 OS	3							1
38	1	119515-23610	METAL ASSY, 0.25	3							3
38-1	1	119515-23611	METAL ASSY, 0.25	3							N 3
		(A=E09945)									

Remarks

- (1) OVER-SIZE(O.S=0.25)PART.
- (2) REPAIR PART.
- (3) UNDER-SIZE(U.S=0.25)PART.

Fig.9. LUB.OIL SYSTEM

(A)=3TNV70-QIK

(B)=

(C)=

(D)=

(E)=

(F)=

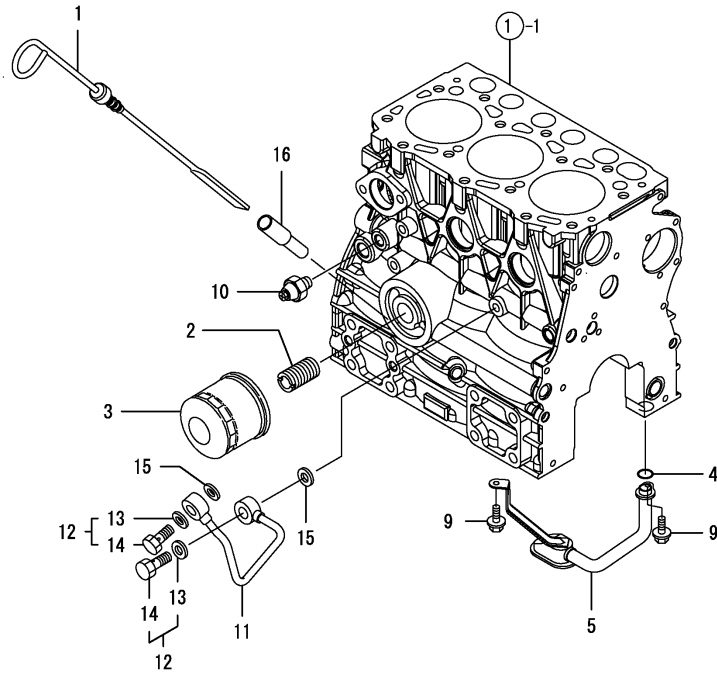

No.	Lev.	Parts No.	Description	Q'ty						I	R
				(A)	(B)	(C)	(D)	(E)	(F)		
1	1	119546-34801	DIPSTICK, OIL	1							
2	1	129100-35140	STUD	1							
3	1	119305-35151	FILTER ASSY, D68XL65	1							1
4	1	119717-32060	O-RING, P15.0	1							
5	1	119546-35080	PIPE ASSY, OIL INLET	1							
9	1	26106-060102	BOLT, M6X 10 PLATED	2							
10	1	121252-39450	SWITCH, 0.5KG	1							
11	1	119717-39210	PIPE, OIL	1							
12	1	129005-59830	BOLT ASSY, JOINT M8	2							
13	2	22190-080002	WASHER, SEAL 6	2							
14	2	23857-030000	BOLT, JOINT 3	2							
15	1	22190-080002	WASHER, SEAL 6	2							
16	1	121520-34810	GUIDE, DIPSTICK	1							

Remarks
(1) REPAIR PART.

Fig.10. COOLING WATER SYSTEM

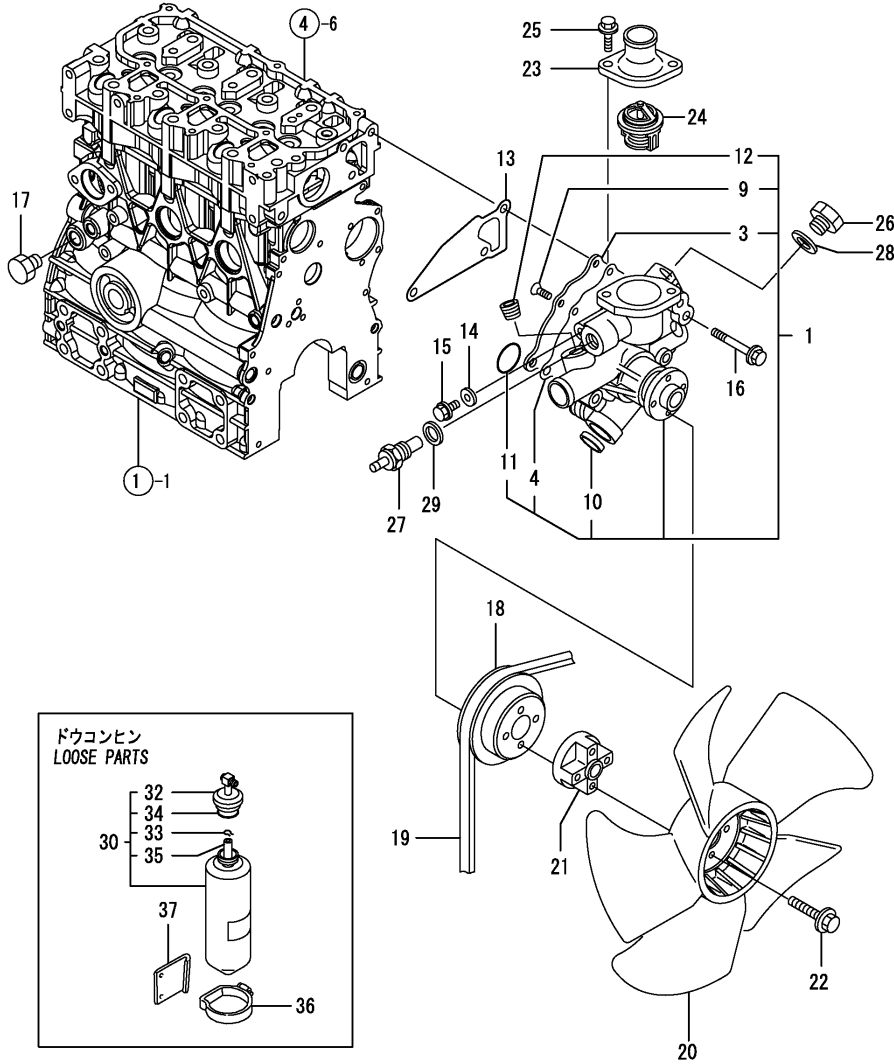

No.	Lev.	Parts No.	Description	Q'ty						I	R
				(A)	(B)	(C)	(D)	(E)	(F)		
1	1	119540-42000	PUMP ASSY, WATER	1							
1-1	1	119C10-42000	PUMP ASSY, WATER	1							N
(A=E/ 85890)											
3	2	119515-42041	COVER	1							
4	2	119717-42031	GASKET	1							
9	2	26577-060122	SCREW, M6X12	4							
10	2	27241-250000	PLUG, 25	1							
11	2	119717-42320	O-RING, P26	1							
11-1	2	119C10-42320	O-RING, 2028	1							S
(A=E/ 85890)											
12	2	129916-49740	PLUG, R03	1							
13	1	119515-42020	GASKET, WATER PUMP	1							
14	1	23414-080000	GASKET, 8X1.0	1							
15	1	26106-080122	BOLT, M8X 12 PLATED	1							
16	1	26106-080502	BOLT, M8X 50 PLATED	3							
17	1	171056-49120	PLUG, DRAIN	1							
18	1	119740-42350	V-PULLEY, D=90	1							
19	1	121522-42290	V-BELT, A34.5	1							
20	1	119233-44740	FAN, D=290XUH	1							
21	1	121267-44760	SPACER	1							
22	1	26106-060302	BOLT, M6X 30 PLATED	4							
23	1	129350-49530	COVER, THERMOSTAT	1							
24	1	119717-49800	THERMOSTAT, 71	1							
25	1	26106-080202	BOLT, M8X 20 PLATED	2							
26	1	121450-42450	PLUG, M16	1							
27	1	171056-49351	SENSOR	1							
28	1	124465-44950	GASKET, 16	1							
29	1	129150-49360	GASKET	1							
30	1	171064-44510	TANK ASSY, SUB	1							
32	2	121450-44531	CAP	1							
33	2	124450-44560	RETAINER	1							
34	2	121470-44581	GASKET	1							
35	2	23065-070225	HOSE 7X 225	1							
36	1	124450-44550	BAND	1							
37	1	121256-44600	BRACKET, SUB TANK	1							

Fig.11. FUEL INJECTION PUMP

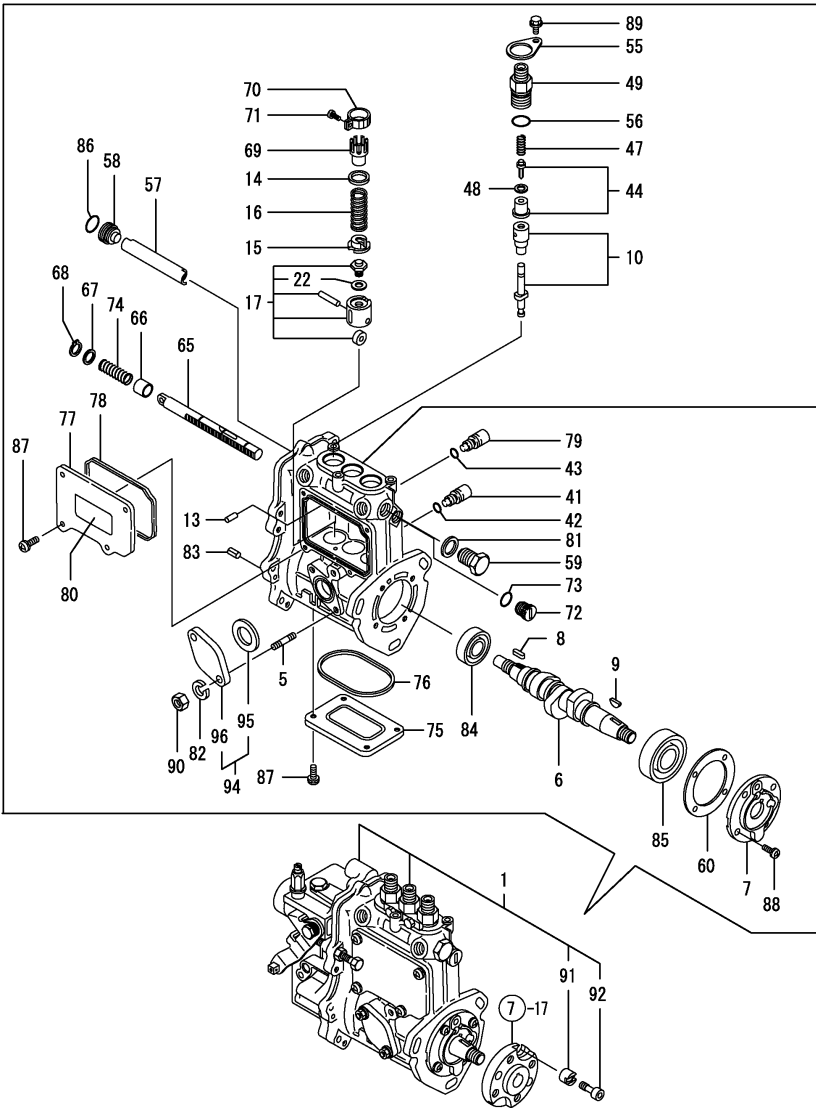

(A)=3TNV70-QIK

(B)=

(C)=

(D)=

(E)=

(F)=

No.	Lev.	Parts No.	Description	Q'ty						I	R
				(A)	(B)	(C)	(D)	(E)	(F)		
1	1	719540-51370	PUMP ASSY, INJECTION	1							1
5	2	129155-51020	STUD	2							
6	2	119717-51030	CAMSHAFT	1							
7	2	119717-51060	SUPPORT, CAMSHAFT	1							
8	2	119717-51070	KEY	1							
9	2	122710-51090	KEY	1							
10	2	119515-51100	PLUNGER ASSY	3							
13	2	129155-51140	PIN	3							
14	2	158600-51170	RETAINER, SPRING	3							
15	2	119717-51180	RETAINER, SPRING	3							
15-1	2	119717-51570	RETAINER, SPRING	3							R
(A=E06342)											
16	2	119717-51190	SPRING, PLUNGER	3							
17	2	119717-51200	TAPPET ASSY	3							
22	3	129155-51600	SHIM SET, ADJUSTING	3							
41	2	158600-51270	STOPPER, TAPPET	3							
42	2	129155-51280	O-RING, S6	3							
43	2	129155-51280	O-RING, S6	1							
44	2	119717-51300	VALVE ASSY, DELIVERY	3							
47	2	119717-51330	SPRING, DELIVERY	3							
48	2	124550-51350	GASKET, DELIVERY	3							
49	2	158600-51441	VALVE ASSY, DELIVERY	3							
49-1	2	158600-51442	VALVE ASSY, DELIVERY	3							N
(A=E04698)											
55	2	118400-51370	LOCKING	3							
56	2	24316-000150	O-RING, 4DP15.0	3							
57	2	129155-51400	DEFLECTOR	1							
58	2	158600-51410	PLUG, DEFLECTOR	1							
59	2	158600-51420	PLUG, DEFLECTOR	1							
60	2	129155-51450	SHIM SET, ADJUSTING	1							
65	2	119717-51500	RACK, CONTROL	1							
66	2	129155-51521	BUSH, RACK	1							
67	2	129155-51530	SPACER	1							
68	2	129155-51540	CIRCLIP	1							
69	2	129155-51550	PINION, CONTROL	3							
70	2	129100-51560	PINION	3							
71	2	129100-51570	SCREW	3							
72	2	158600-51570	PLUG	1							
73	2	129155-51580	O-RING	1							
74	2	129155-51591	SPRING, RACK	1							
75	2	129155-51701	COVER	1							
76	2	119717-51710	GASKET	1							
76-1	2	119717-51711	GASKET	1							N
(A=E09275)											
77	2	119717-51750	COVER	1							
78	2	119717-51760	GASKET	1							
78-1	2	119717-51761	GASKET	1							N
(A=E09275)											
79	2	158600-51790	STOOPER, RACK	1							
80	2	129156-51910	LABEL, CAUTION	1							Z
(A=E09275)											

Remarks
 (1) GOVERNOR ASSY(FIG.12) IS
 INCORPORATED IN THIS FOP.CMP
 (REF.NO.1).

Fig.11. FUEL INJECTION PUMP

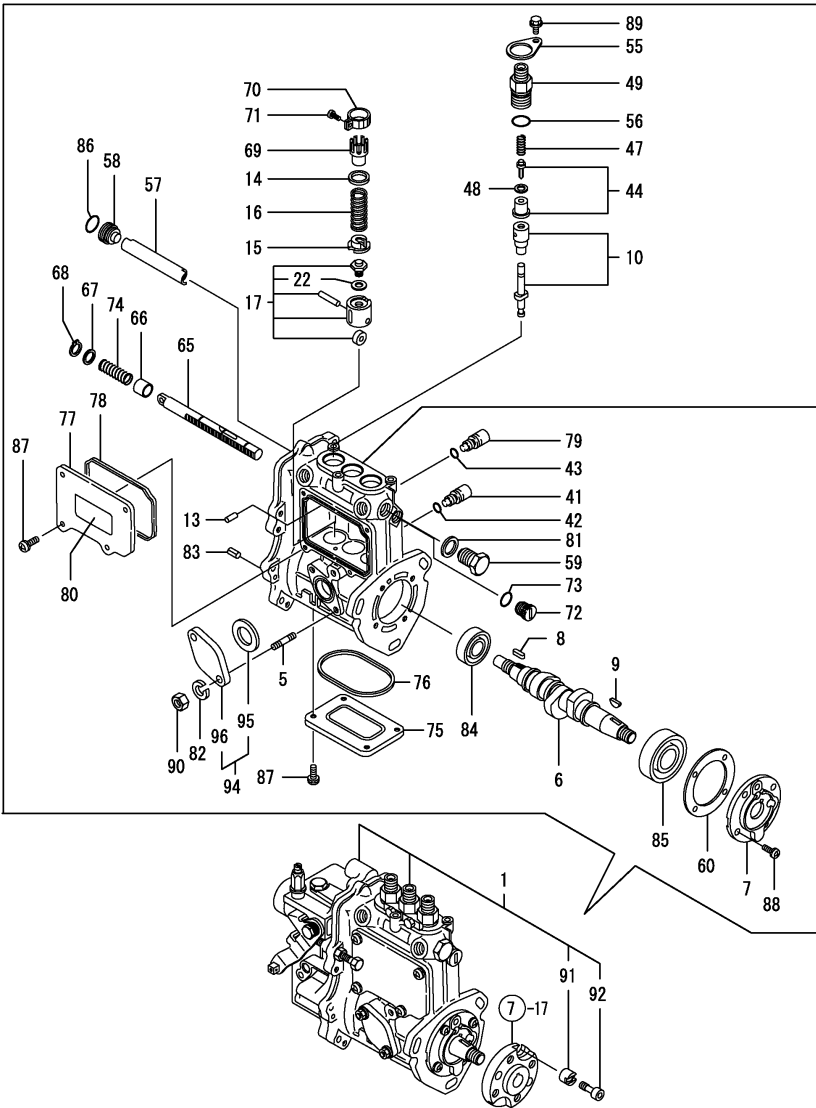

(A)=3TNV70-QIK
(B)=
(C)=

(D)=
(E)=
(F)=

No.	Lev.	Parts No.	Description	Q'ty						I	R
				(A)	(B)	(C)	(D)	(E)	(F)		
81	2	22190-160002	WASHER, SEAL 16	1							
82	2	22217-060000	WASHER, SPRING 6	2							
83	2	22351-050010	PIN, SPRING 5.0X10	2							
84	2	24101-060034	BEARING, BALL 6003	1							
85	2	24101-063034	BEARING, BALL 6303	1							
86	2	119717-51420	O-RING	1							
87	2	26022-050122	SCREW, M5X12	8							
88	2	26022-060162	SCREW, M6X16	4							
89	2	26106-050102	BOLT, M5X 10 PLATED	3							
90	2	26716-060002	NUT, M6	2							
91	2	119717-51480	COLLAR	1							
92	2	119717-51490	BOLT	1							
94	2	129255-52000	COVER ASSY	1							
95	3	129155-52051	GASKET	1							
96	3	129100-52200	COVER	1							

Remarks
(1) GOVERNOR ASSY(FIG.12) IS
INCORPORATED IN THIS FOP.CMP
(REF.NO.1).

Fig.12. GOVERNOR

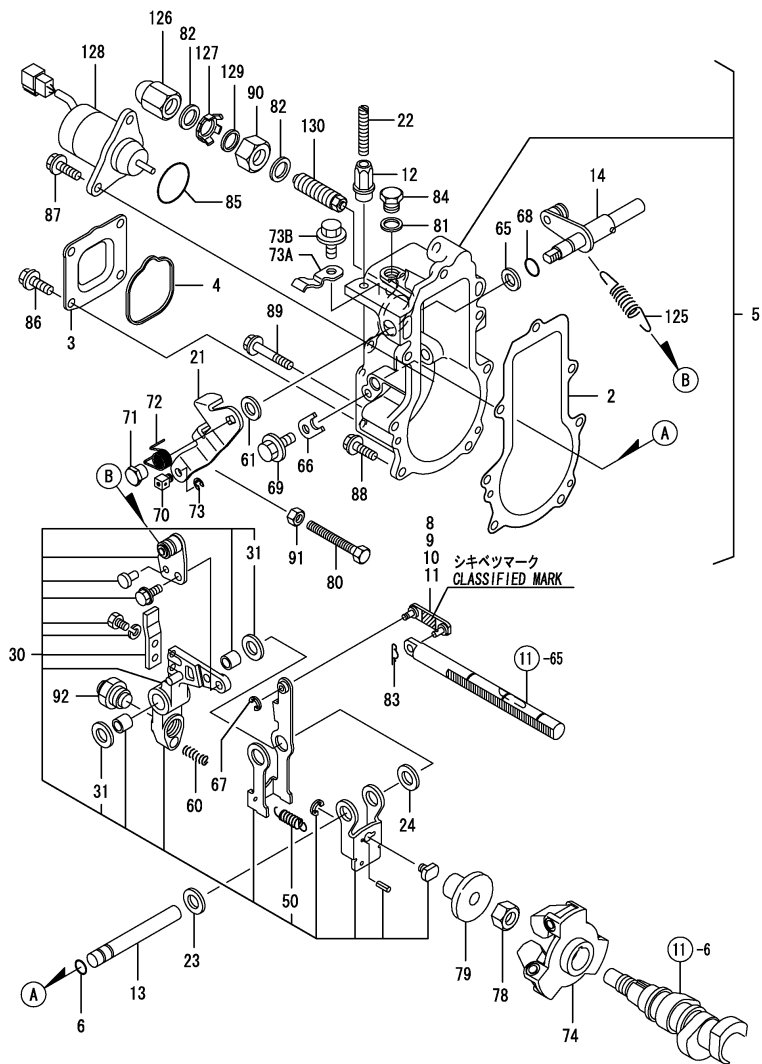

Remarks
 (1) SELECTIVE PARTS: CERTAIN THE CLASSIFICATION MARK, THEN PLACE YOUR ORDER. (REF. TO ILLUSTRATION).
 * THIS FIGURE (GOVERNOR ASSY) IS INCORPORATED IN THE FUEL INJECTION PUMP ASSY (FIG. 11).

(A)=3TNV70-QIK
 (B)=
 (C)=

(D)=
 (E)=
 (F)=

No.	Lev.	Parts No.	Description	Q'ty						I	R
				(A)	(B)	(C)	(D)	(E)	(F)		
2	2	119717-61050	GASKET	1							
3	2	119717-61060	COVER, GOVERNOR CASE	1							
4	2	119717-61070	GASKET	1							
5	2	119540-61200	CASE ASSY, GOVERNOR	1							
6	3	129155-51280	O-RING, S6	1							
8	3	119717-61120	LINK, MARK :3	1							1
9	3	119717-61130	LINK, MARK 98	1							1
10	3	119717-61140	LINK, MARK 88	1							1
11	3	119717-61150	LINK, MARK 03	1							1
12	3	129209-61370	NUT, M6	1							
13	3	129052-61390	SHAFT	1							
14	3	119717-61400	SHAFT ASSY	1							
21	3	119740-61440	LEVER, CONTROL	1							
22	3	129155-61450	BOLT, LIMITER	1							
23	3	129156-61460	SHIM, T=0.6	1							
24	3	129155-61480	SPACER ASSY	1							
30	3	119717-61500	LEVER ASSY, GOVERNOR	1							
31	4	174307-51700	SHIM SET	2							
50	4	129486-61540	SPRING, SET	1							
60	3	129100-61650	SPRING, CONTROLLER	1							
61	3	158552-61700	SHIM SET	1							
65	3	158552-61710	SHIM, T=1.0	1							
66	3	119660-61901	RETAINER, SHAFT	1							
67	3	22272-000030	RING, E- 3	1							
68	3	24341-000070	O-RING, 1AS7.0	1							
69	3	26106-060102	BOLT, M6X 10 PLATED	1							
70	3	124066-03770	RETAINER	1							
71	3	129255-61410	NUT, LOCK	1							
72	3	129255-61420	SPRING, RETURN	1							
72-1	3	119534-61420	SPRING	1							N
(A=E06342)											
73	3	22272-000050	RING, E- 5	1							
73A	3	119534-61430	RETAINER	1							W
(A=E06342)											
73B	3	26106-060102	BOLT, M6X 10 PLATED	1							W
(A=E06342)											
74	2	119717-61200	WEIGHT ASSY, GOVERNOR	1							
78	2	119660-61300	NUT	1							
79	2	129155-61341	SLEEVE	1							
80	2	129155-61460	BOLT, IDLE	1							
81	2	22190-100002	WASHER, SEAL 10	1							
82	2	22190-120002	WASHER, SEAL 12	2							
83	2	22372-040000	PIN, SNAP 4	1							
84	2	23887-100002	PLUG, 10	1							
85	2	24341-000280	O-RING, 1AS28.0	1							
85-1	2	158552-61900	O-RING	1							N
(A=EXXXXX)											
86	2	26106-060102	BOLT, M6X 10 PLATED	4							
87	2	26106-060142	BOLT, M6X 14 PLATED	2							
88	2	26106-060202	BOLT, M6X 20 PLATED	4							
89	2	26106-060452	BOLT, M6X 45 PLATED	3							

Fig.12. GOVERNOR

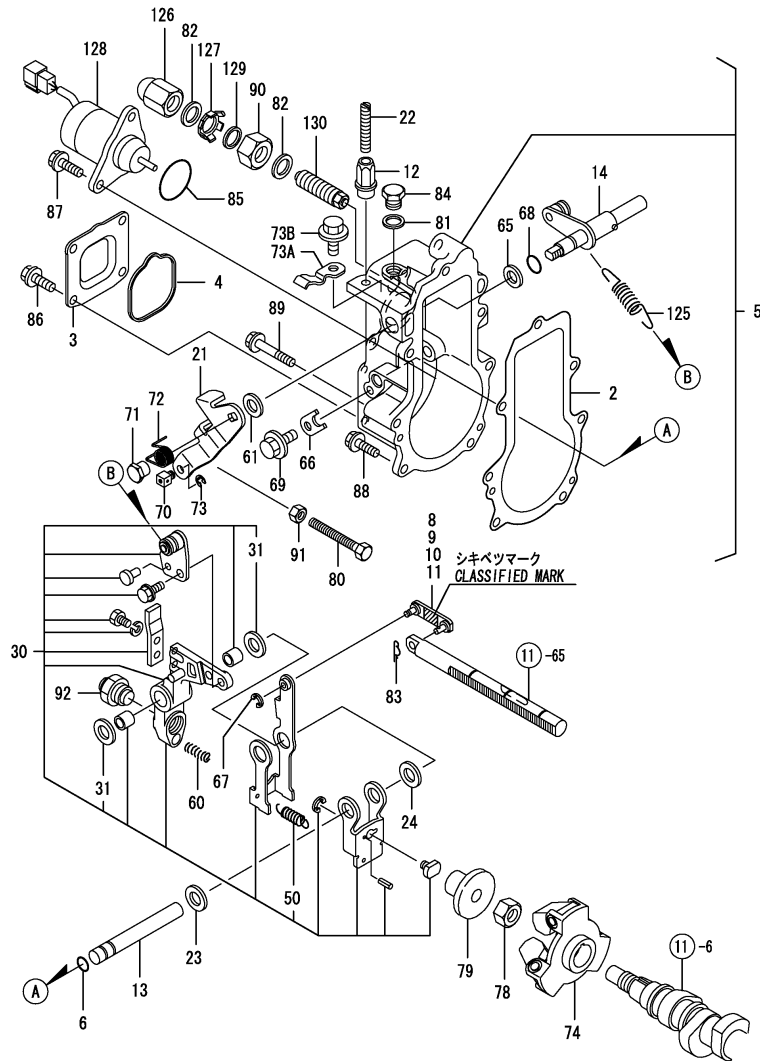

(A)=3TNV70-QIK

(B)=

(C)=

(D)=

(E)=

(F)=

No.	Lev.	Parts No.	Description	Q'ty						I	R
				(A)	(B)	(C)	(D)	(E)	(F)		
90	2	26736-120002	NUT, M12	1							
91	2	26756-060002	NUT, LOCK M6	1							
92	2	119740-61550	ANGLEICH ASSY	1							
125	2	171353-61700	SPRING, GOVERNOR	1							
126	2	129209-61930	NUT, CAP	1							
127	2	129209-61970	PLATE	1							
128	2	119233-77932	SOLENOID, STOP	1							
129	2	23414-120016	GASKET, 12X1.0	1							
130	2	158601-61790	LIMITER ASSY, FUEL	1							

Remarks

(1) SELECTIVE PARTS: CERTAIN THE CLASSIFICATION MARK, THEN PLACE YOUR ORDER. (REF. TO ILLUSTRATION).
 * THIS FIGURE (GOVERNOR ASSY) IS INCORPORATED IN THE FUEL INJECTION PUMP ASSY (FIG. 11).

Fig.13. FUEL INJECTION VALVE

(A)=3TNV70-QIK

(B)=

(C)=

(D)=

(E)=

(F)=

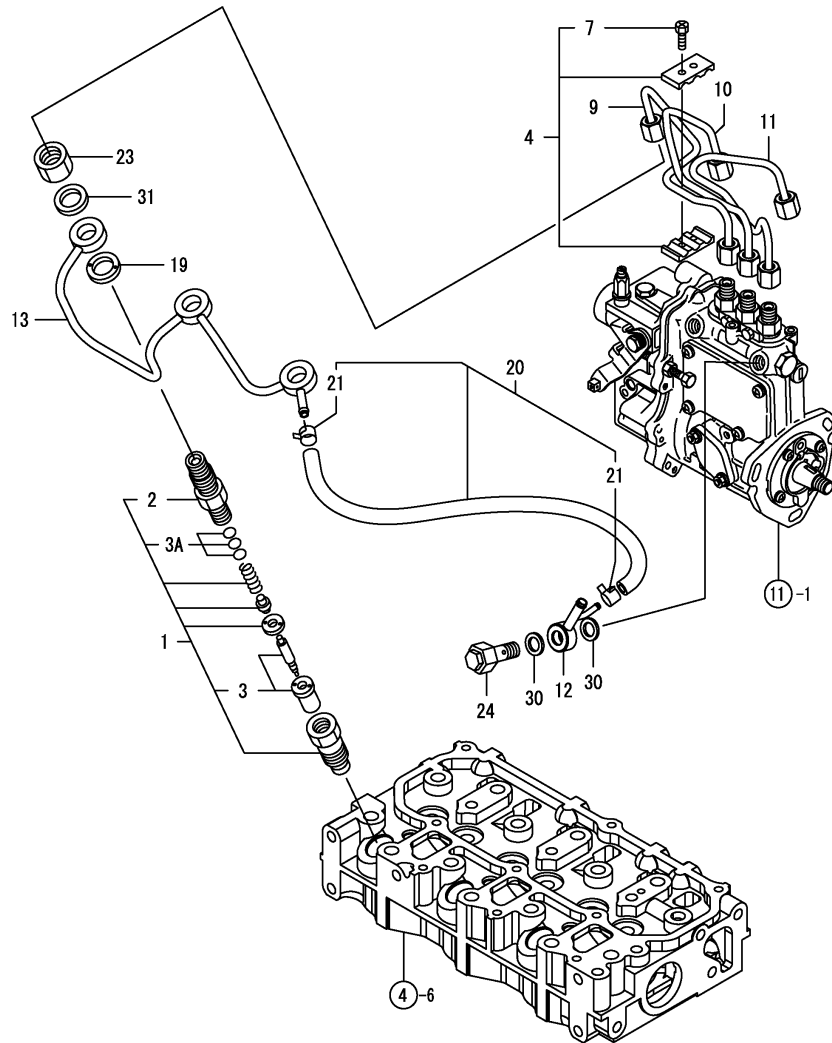

No.	Lev.	Parts No.	Description	Q'ty						I	R
				(A)	(B)	(C)	(D)	(E)	(F)		
1	1	119515-53001	VALVE ASSY,INJECTION	3							
2	2	118200-53010	HOLDER, NOZZLE	3							
3	2	119515-53010	VALVE ASSY,INJECTION	3							
3A	2	129901-53800	SHIM SET, ADJUSTING	3							W 1
(A=FROM 1ST)											
4	1	129150-59120	RETAINER, PIPE	1							
7	2	129150-59131	BOLT, M4X14	2							
9	1	119546-59810	PIPE ASSY, INJECTION	1							
10	1	119546-59820	PIPE ASSY, INJECTION	1							
11	1	119546-59830	PIPE ASSY, INJECTION	1							
12	1	119840-59570	JOINT	1							
13	1	119515-59540	PIPE ASSY, RETURN	1							
19	1	129901-59560	GASKET	3							
20	1	119540-59570	PIPE ASSY, RETURN	1							
21	2	124066-59100	CLIP, HOSE 8	2							
23	1	119620-59700	NUT, NOZZLE	3							
24	1	119813-59950	VALVE ASSY, CHECK	1							
30	1	22190-120002	WASHER, SEAL 12	2							
31	1	22190-120002	WASHER, SEAL 12	3							W
(A=FROM 1ST)											

Remarks
(1) REPAIR PART.

Fig.14. FUEL LINE

(A)=3TNV70-QIK

(B)=

(C)=

(D)=

(E)=

(F)=

Q'ty

I R

No.	Lev.	Parts No.	Description	(A)	(B)	(C)	(D)	(E)	(F)	I	R
1	1	119833-55620	FILTER ASSY, FUEL	1							
2	2	104200-55330	SPRING, VALVE	1							
3	2	119810-55340	LEVER	1							
4	2	121254-55510	COVER	1							
5	2	102103-55520	O-RING	1							
6	2	110250-55610	RING, RETAINING	1							
7	2	121250-55620	SPRING	1							
8	2	119810-55650	ELEMENT	1							
9	2	104200-55750	SCREW, M4	1							
10	2	24311-240100	O-RING, 1AP10A	1							
11	1	119225-52102	PUMP ASSY, FUEL FEED	1							
12	1	103854-39140	BOLT, PIPE JOINT	1							
13	1	101304-59020	JOINT, PIPE 12	1							
14	1	22190-120002	WASHER, SEAL 12	2							
15	1	129335-55700	SEPARATOR ASSY,WATER	1							
16	2	24311-240100	O-RING, 1AP10A	1							
17	2	104200-55321	VALVE, TAPER	1							
18	2	104200-55330	SPRING, VALVE	1							
19	2	104200-55341	HANDLE	1							
20	2	124064-55510	COVER	1							
21	2	102103-55520	O-RING	1							
22	2	110250-55610	RING, RETAINING	1							
23	2	121257-55720	SPRING	1							
24	2	121257-55731	FLOAT	1							
26	2	101720-55750	PLUG, 6	2							
27	2	104200-55750	SCREW, M4	1							
28	2	171081-55910	SCREEN	1							
29	2	23418-060000	GASKET, 6X1.0	2							

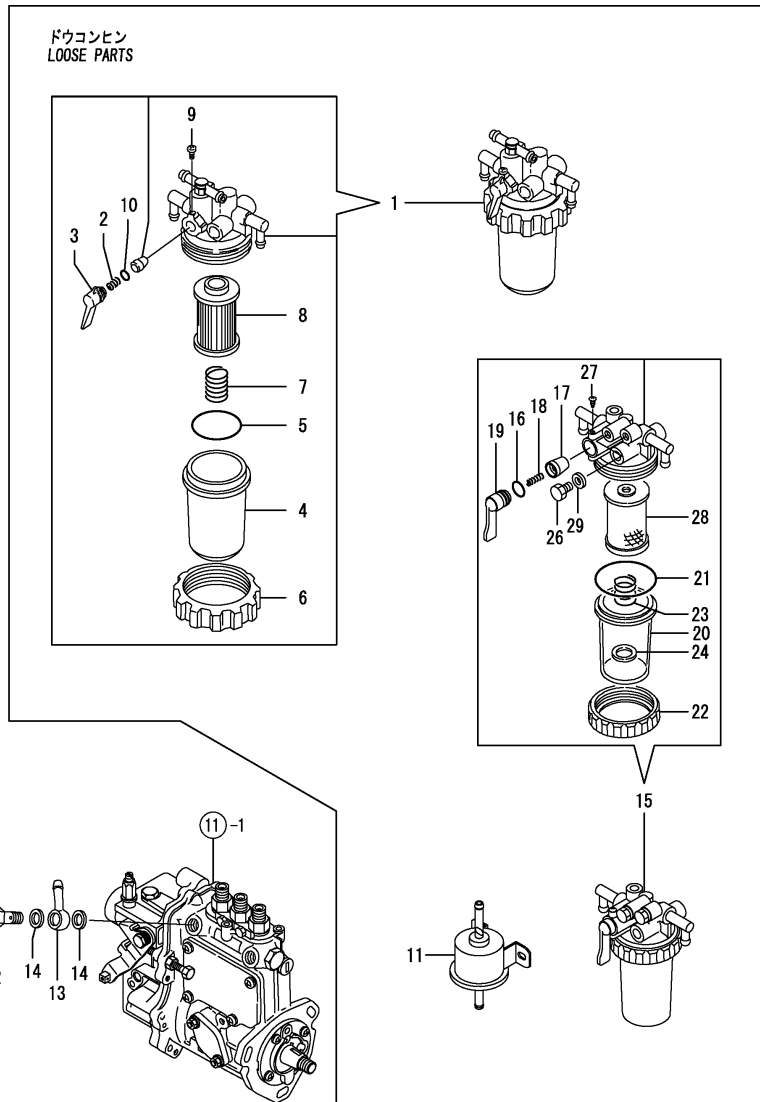

Remarks

*This item is applicable to [(A)=EXXXXX-1] or previous machines. Refer to Fig.19.

Fig.18. (14A)FUEL LINE

(A)=3TNV70-QIK

(B)=

(C)=

(D)=

(E)=

(F)=

Qty

No.	Lev.	Parts No.	Description	Qty						I	R
				(A)	(B)	(C)	(D)	(E)	(F)		
1	1	119833-55620	FILTER ASSY, FUEL	1							
2	2	104200-55330	SPRING, VALVE	1							
3	2	119810-55340	LEVER	1							
4	2	121254-55510	COVER	1							
5	2	102103-55520	O-RING	1							
6	2	110250-55610	RING, RETAINING	1							
7	2	121250-55620	SPRING	1							
8	2	119810-55650	ELEMENT	1							
9	2	104200-55750	SCREW, M4	1							
10	2	24311-240100	O-RING, 1AP10A	1							
11	1	119225-52102	PUMP ASSY, FUEL FEED	1							
12	1	103854-39140	BOLT, PIPE JOINT	1							
13	1	101304-59020	JOINT, PIPE 12	1							
14	1	22190-120002	WASHER, SEAL 12	2							
15	1	129335-55750	SEPARATOR ASSY,WATER	1							
16	2	129053-55640	FLOAT	1							
17	2	129053-55650	SPRING, SCREEN	1							
18	2	119833-55660	RING, RETAINING	1							
19	2	129335-55740	CUP	1							
20	2	129335-55770	BODY ASSY	1							
21	3	129242-55750	VALVE, AIR VENT	2							
22	3	129242-55760	GASKET	2							
23	3	24311-000110	O-RING, 1AP11.0	1							
24	2	129335-55780	ELEMENT ASSY	1							
25	2	24311-000440	O-RING, 1AP44.0	1							

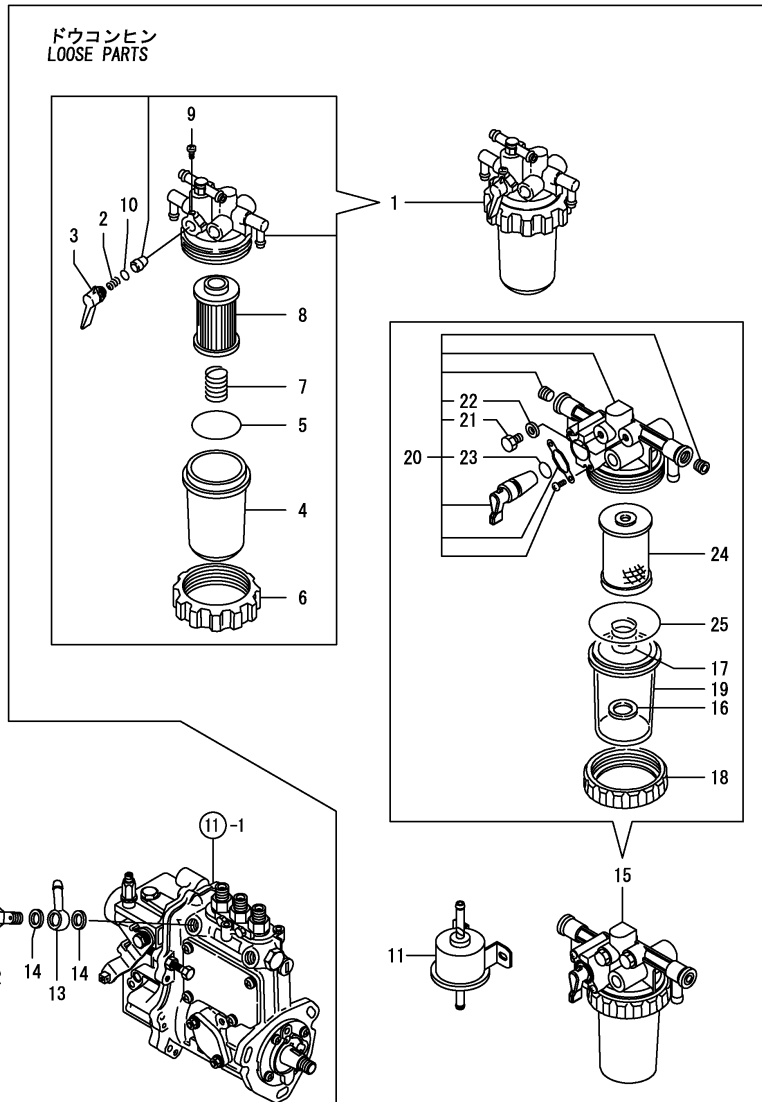

Remarks

*This item is applicable to [(A)=EXXXXX] or following machines. Refer to Fig.14.

Fig.15. STARTING MOTOR

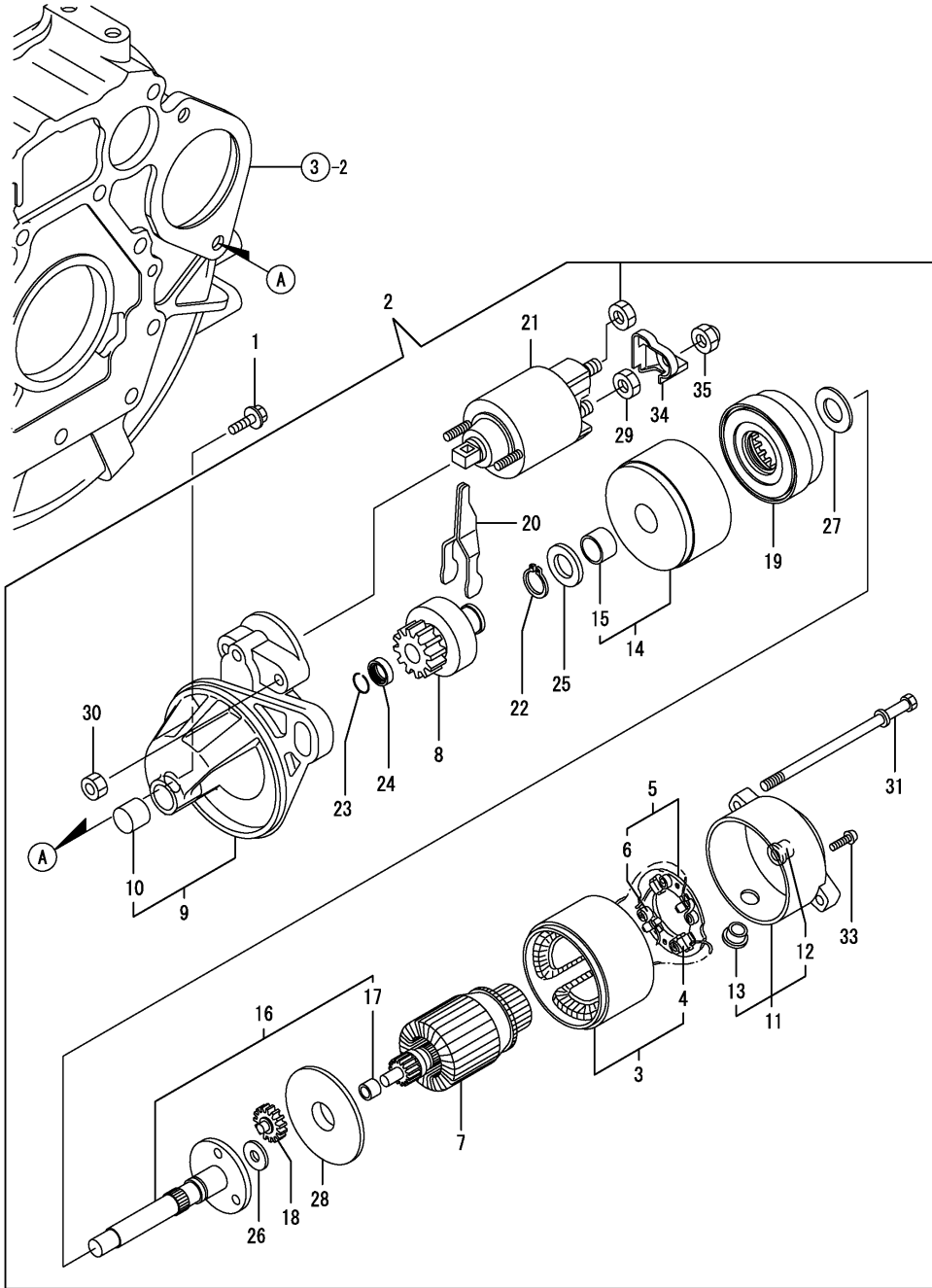

(A)=3TNV70-QIK

(B)=

(C)=

(D)=

(E)=

(F)=

No.	Lev.	Parts No.	Description	Q'ty						I	R
				(A)	(B)	(C)	(D)	(E)	(F)		
1	1	26106-100252	BOLT, M10X 25 PLATED	2							
2	1	119717-77010	STARTER, P1.1	1							
3	2	X0281007750	YOKE ASSY	1							
4	3	X0280996180	STARTER KIT	2							
5	2	X0285105190	HOLDER ASSY	1							
6	3	X0285205030	SPRING	4							
7	2	X0282005991	ARMATURE ASSY	1							
8	2	X0283006960	CLUTCH ASSY	1							
9	2	X4284001590	HOUSING ASSY	1							
10	3	X9491050100	BEARING, NEEDLE	1							
11	2	X0285007030	FRAME ASSY	1							
12	3	X9491040990	BEARING	1							
13	3	X0280626010	COVER	1							
14	2	X0284105040	BEARING ASSY	1							
15	3	X9491034330	BEARING	1							
16	2	X0286105010	SHAFT ASSY	1							
17	3	X9491034320	BEARING	1							
18	2	X0286305010	GEAR	3							
19	2	X0286355010	GEAR	1							
20	2	X0287405140	LEVER	1							
21	2	X0534007800	SWITCH ASSY	1							
22	2	X9055715000	RING	1							
23	2	X9490721360	RING	1							
24	2	X0280210331	NUT	1							
25	2	X9490138110	WASHER	1							
26	2	X9490138090	WASHER	1							
27	2	X9490138100	WASHER	1							
28	2	X0284525010	PLATE	1							
29	2	X9490562360	NUT	1							
30	2	X9490560750	NUT	2							
31	2	X9490423420	BOLT, THROUGH	2							
33	2	X9490065670	SCREW, M4X6	2							
34	2	X0280335350	COVER, TERMINAL	1							
35	2	X1289510130	NUT	1							

Fig.16. GENERATOR

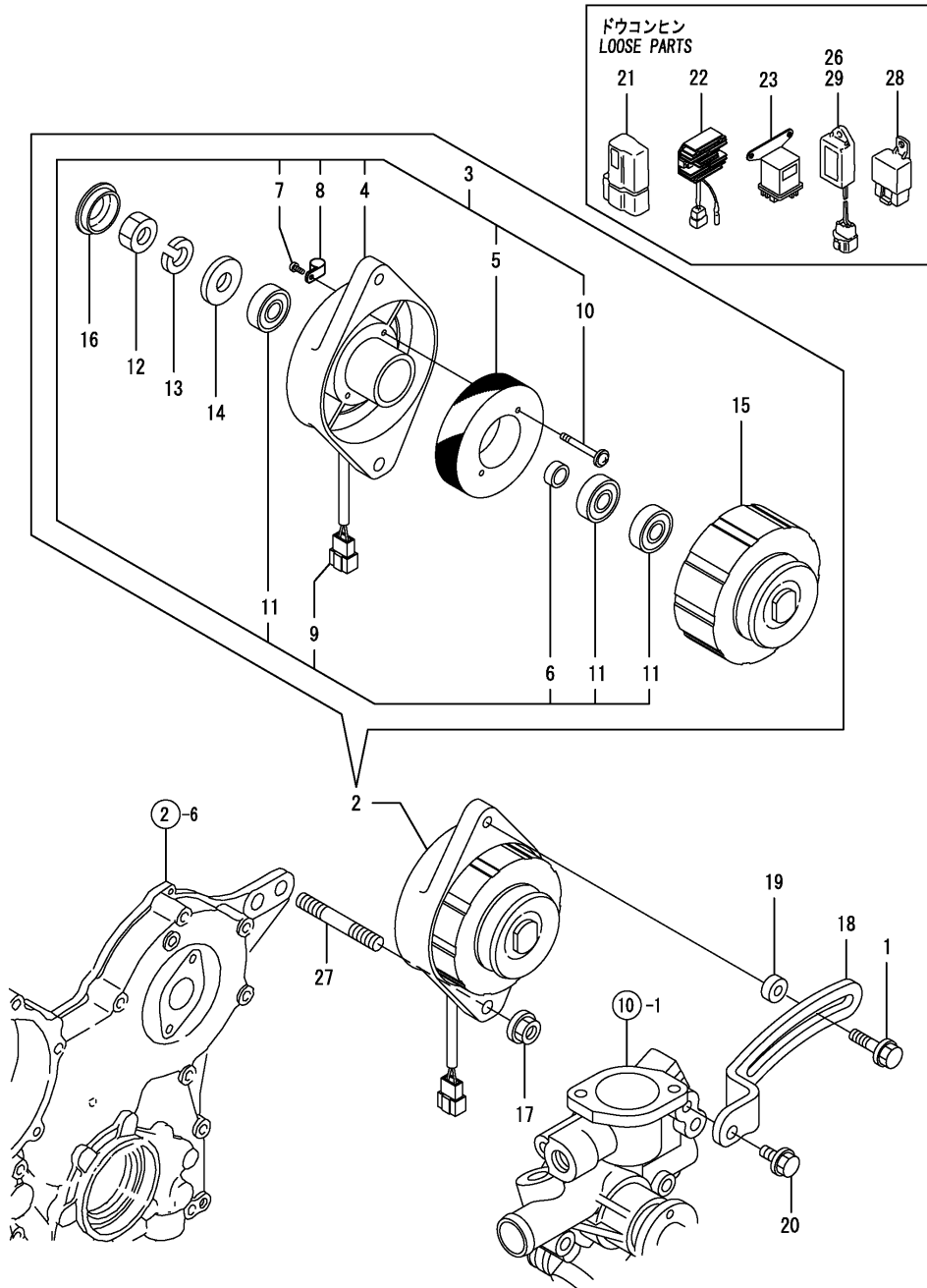

(A)=3TNV70-QIK

(B)=

(C)=

(D)=

(E)=

(F)=

No.	Lev.	Parts No.	Description	Q'ty						I	R
				(A)	(B)	(C)	(D)	(E)	(F)		
1	1	129972-77341	BOLT, ADJUSTER L=50	1							
2	1	119910-77200	DYNAMO ASSY	1							
3	2	X2A10592KA	PLATE ASSY	1							
4	3	X2A07075KB	PLATE, COIL	1							
5	3	X3A02982KC	STATOR ASSY	1							
6	3	X4A10092KA	COLLAR	1							
7	3	XYSPS400800	SCREW	1							
8	3	XM069000000	CLAMP	1							
9	3	XM771860000	COUPLER	1							
10	3	119259-77250	SCREW	2							
11	3	24104-062010	BEARING, 6201UUC3	3							
12	2	XM863720000	NUT	1							
13	2	XM219230000	WASHER	1							
14	2	XM860250000	WASHER	1							
15	2	X3A08863KA	FLYWHEEL ASSY	1							
16	2	XM771870000	CAP	1							
17	1	26306-100002	NUT, M10	1							Z
(A=E09275)											
18	1	119734-77330	ADJUSTER	1							
19	1	119940-77270	SPACER, GENERATOR	1							
20	1	26106-080202	BOLT, M8X 20 PLATED	1							
21	1	119643-66900	DIODE	1							
22	1	119653-77710	LIMITER, CURRENT	1							
23	1	119650-77910	RELAY ASSY, GLOW	1							
26	1	129211-77920	TIMER	1							
27	1	129795-01900	STUD	1							
27-1	1	26106-100452	BOLT, M10X 45 PLATED	1							N
(A=E04151)											
28	1	119247-77100	RELAY, SAFETY	3							
29	1	129155-77925	TIMER	1							

Fig.17. GASKET SET

(A)=3TNV70-QIK

(B)=

(C)=

(D)=

(E)=

(F)=

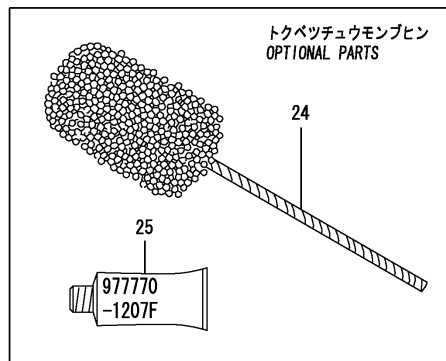
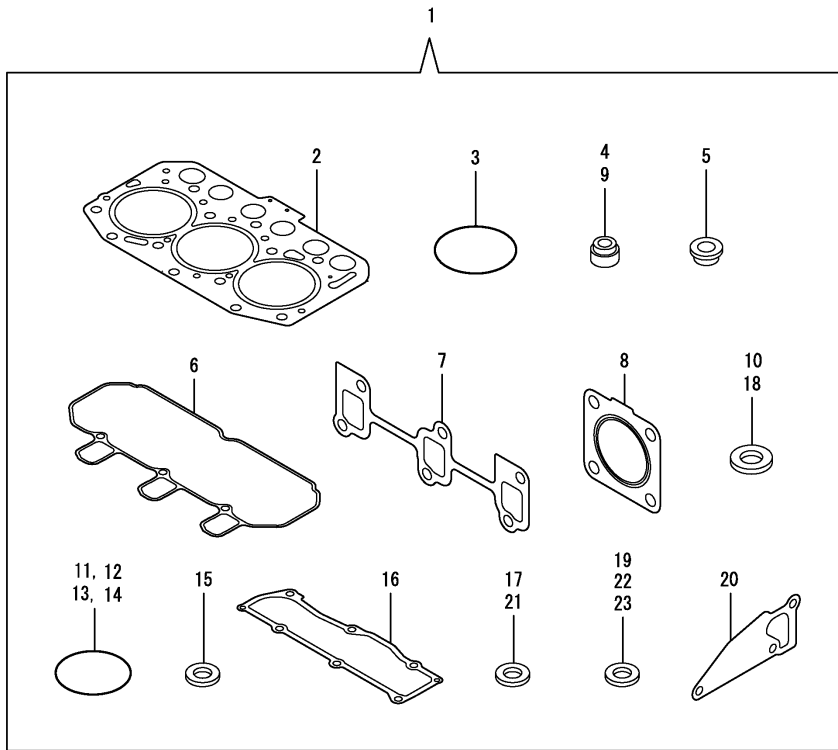

No.	Lev.	Parts No.	Description	Q'ty						I	R
				(A)	(B)	(C)	(D)	(E)	(F)		
1	1	719515-92640	GASKET SET	1							1
2	2	119515-01330	GASKET, HEAD	1							
3	2	121850-51960	O-RING	1							
4	2	119717-11340	SEAL, VALVE STEM	3							
5	2	129901-11450	PROTECTOR, NOZZLE	3							
6	2	119515-11310	GASKET, BONNET	1							
7	2	119717-13110	GASKET	1							
8	2	119515-13200	GASKET, SILENCER	3							
9	2	119717-11350	SEAL, VALVE STEM	3							
10	2	22190-080002	WASHER, SEAL 6	4							
11	2	24311-000320	O-RING, 1AP32.0	2							
12	2	119717-32060	O-RING, P15.0	1							
13	2	119624-32040	O-RING, P12.0	1							
14	2	119717-32050	O-RING, P17.0	3							
15	2	119600-11460	GASKET, NOZZLE	6							
16	2	119515-11330	GASKET	1							
17	2	22190-160002	WASHER, SEAL 16	1							
18	2	22190-120002	WASHER, SEAL 12	7							
19	2	129901-59560	GASKET	3							
20	2	119515-42020	GASKET, WATER PUMP	1							
21	2	23414-080000	GASKET, 8X1.0	1							
22	2	124465-44950	GASKET, 16	1							
23	2	129150-49360	GASKET	1							
24	1	129400-92410	HONE	1							1
25	1	977770-1207F	GASKET.LIQUID	1							1

Remarks
(1) OPTIONAL PART.

Parts No. Index

Parts No.	Fig. No.	Ref. No.
101304-59020	14	13
	18	13
101720-55750	14	26
102103-55520	14	5
		21
	18	5
103854-39140	14	12
	18	12
104200-55321	14	17
104200-55330	14	2
		18
	18	2
104200-55341	14	19
104200-55750	14	9
		27
	18	9
105010-11490	4	5
105027-12580	5	5
105311-01090	1	6
105425-01690	3	7
110250-55610	14	6
		22
	18	6
118200-53010	13	2
118400-51370	11	55
119131-18320	6	5
119225-52102	14	11
	18	11
119226-07900	4	1
119233-12700	5	8
119233-44740	10	20
119233-77932	12	128
119247-77100	16	28
119259-77250	16	10
119285-01990	1	9
119285-11990	4	13
119305-35151	9	3
119515-01200	1	30
119515-01330	1	31
	17	2
119515-01601	3	2
119515-01720	3	4
119515-11100	4	15
119515-11101	4	15 -1
119515-11110	4	16
119515-11200	4	23
119515-11240	4	24
119515-11280	4	28
119515-11310	4	48
	17	6

Parts No.	Fig. No.	Ref. No.
119515-11320	4	49
119515-11330	4	50
	17	16
119515-11380	4	37
119515-11740	4	6
119515-11800	4	11
119515-12520	5	2
119515-12610	5	1
119515-13200	6	7
	17	8
119515-13530	6	8
119515-14400	7	2
119515-14580	7	3
119515-14581	7	3 -1
119515-21580	8	9
119515-21700	8	1
119515-22080	8	16
119515-22300	8	22
119515-22500	8	18
119515-22550	8	34
119515-22900	8	32
119515-23000	8	24
119515-23301	8	31 -1
119515-23600	8	30
119515-23601	8	30 -1
119515-23610	8	38
119515-23611	8	38 -1
119515-42020	10	13
	17	20
119515-42041	10	3
119515-51100	11	10
119515-53001	13	1
119515-53010	13	3
119515-59540	13	13
119534-61420	12	72 -1
119534-61430	12	73 A
119540-07910	4	59
119540-13100	6	1
119540-42000	10	1
119540-59570	13	20
119540-61200	12	5
119546-01770	3	6
119546-34801	9	1
119546-35080	9	5
119546-59810	13	9
119546-59820	13	10
119546-59830	13	11
119600-11460	4	4
	17	15
119620-01750	3	13

Parts No.	Fig. No.	Ref. No.
119620-01800	2	8
119620-02020	1	10
119620-14200	7	1
119620-21500	8	8
119620-21941	8	15
119620-59700	13	23
119621-21680	8	14
119623-01250	1	7
119624-32040	2	20
	17	13
119643-66900	16	21
119650-77910	16	23
119653-77710	16	22
119655-12570	5	4
119660-01911	2	19
119660-61300	12	78
119660-61901	12	66
119717-01501	2	1
119717-01521	2	6
119717-01570	2	3
119717-01590	2	4
119717-01750	2	18
119717-02410	1	13
119717-02411	1	13 -1
119717-02930	1	27
119717-03031	4	38
119717-03070	4	39
		40
119717-11131	4	17
119717-11190	4	19
119717-11260	4	27
119717-11340	4	20
	17	4
119717-11350	4	21
	17	9
119717-11650	4	29
119717-13110	6	2
	17	7
119717-13600	6	3
119717-21200	8	6
119717-21650	8	13
119717-23200	8	29
119717-23910	8	28
119717-25050	7	10
119717-25100	7	11
119717-25101	7	11 -1
119717-25930	7	16
119717-32050	2	21
	17	14
119717-32060	9	4

Parts No.	Fig. No.	Ref. No.
119717-32060	17	12
119717-32080	2	11
119717-32100	2	10
119717-32110	2	15
119717-32120	2	16
119717-39210	9	11
119717-42031	10	4
119717-42320	10	11
119717-49800	10	24
119717-51030	11	6
119717-51060	11	7
119717-51070	11	8
119717-51150	7	17
119717-51180	11	15
119717-51190	11	16
119717-51200	11	17
119717-51300	11	44
119717-51330	11	47
119717-51420	11	86
119717-51480	11	91
119717-51490	11	92
119717-51500	11	65
119717-51570	11	15 -1
119717-51710	11	76
119717-51711	11	76 -1
119717-51750	11	77
119717-51760	11	78
119717-51761	11	78 -1
119717-61050	12	2
119717-61060	12	3
119717-61070	12	4
119717-61120	12	8
119717-61130	12	9
119717-61140	12	10
119717-61150	12	11
119717-61200	12	74
119717-61400	12	14
119717-61500	12	30
119717-77010	15	2
119717-77800	4	57
119717-77820	4	58
119734-77330	16	18
119740-42350	10	18
119740-61440	12	21
119740-61550	12	92
119802-03100	4	41
119802-03110	4	42
119802-03121	4	43
119802-03131	4	44
119802-03141	4	45

Parts No. Index

Parts No.	Fig. No.	Ref. No.
119802-13620	6	4
119802-32130	2	17
119808-12540	5	3
119810-02940	1	32
119810-02941	1	32 -1
119810-55340	14	3
	18	3
119810-55650	14	8
	18	8
119813-59950	13	24
119833-55620	14	1
	18	1
119833-55660	18	18
119840-59570	13	12
119910-77200	16	2
119940-77270	16	19
119C10-42000	10	1 -1
119C10-42320	10	11 -1
121120-01620	3	15
121250-55620	14	7
	18	7
121252-39450	9	10
121254-55510	14	4
	18	4
121256-44600	10	37
121257-55720	14	23
121257-55731	14	24
121267-44760	10	21
121450-42450	10	26
121450-44531	10	32
121470-44581	10	34
121520-34810	9	16
121522-42290	10	19
121850-51960	2	22
	17	3
122710-51090	11	9
124060-01050	1	5
124064-55510	14	20
124066-03770	12	70
124066-59100	13	21
124085-02220	3	3
124160-01751	2	30
	4	36
124160-01910	1	8
124450-44550	10	36
124450-44560	10	33
124465-44950	10	28
	17	22
124550-51350	11	48
124950-21600	8	12

Parts No.	Fig. No.	Ref. No.
126650-12680	5	7
129001-32320	2	13
129001-32330	2	14
129005-59830	9	12
129052-61390	12	13
129053-55640	18	16
129053-55650	18	17
129100-01580	3	1
	8	2
129100-35140	9	2
129100-51560	11	70
129100-51570	11	71
129100-52200	11	96
129100-61650	12	60
129150-11230	4	30
129150-11750	4	32
129150-25301	7	15
129150-49360	10	29
	17	23
129150-59120	13	4
129150-59131	13	7
129155-51020	11	5
129155-51140	11	13
129155-51280	11	42
		43
	12	6
129155-51400	11	57
129155-51450	11	60
129155-51521	11	66
129155-51530	11	67
129155-51540	11	68
129155-51550	11	69
129155-51580	11	73
129155-51591	11	74
129155-51600	11	22
129155-51701	11	75
129155-52051	11	95
129155-61341	12	79
129155-61450	12	22
129155-61460	12	80
129155-61480	12	24
129155-77925	16	29
129156-51910	11	80
129156-61460	12	23
129209-61370	12	12
129209-61930	12	126
129209-61970	12	127
129211-77920	16	26
129242-55750	18	21
129242-55760	18	22

Parts No.	Fig. No.	Ref. No.
129255-52000	11	94
129255-61410	12	71
129255-61420	12	72
129335-55700	14	15
129335-55740	18	19
129335-55750	18	15
129335-55770	18	20
129335-55780	18	24
129350-49530	10	23
129400-92410	17	24
129486-61540	12	50
129508-11180	4	18
129612-12650	5	6
129795-01900	16	27
129900-32130	2	12
129901-11450	4	3
	17	5
129901-53800	13	3 A
129901-59560	13	19
	17	19
129916-49740	10	12
129972-77341	16	1
158552-61700	12	61
158552-61710	12	65
158552-61900	12	85 -1
158600-51170	11	14
158600-51270	11	41
158600-51410	11	58
158600-51420	11	59
158600-51441	11	49
158600-51442	11	49 -1
158600-51570	11	72
158600-51790	11	79
158601-61790	12	130
171056-49120	10	17
171056-49351	10	27
171064-44510	10	30
171081-55910	14	28
171353-61700	12	125
174307-51700	12	31
22190-080002	9	13
		15
	17	10
	12	81
22190-100002	12	82
22190-120002	13	30
		31
	14	14
	17	18
	18	14

Parts No.	Fig. No.	Ref. No.
22190-160002	3	9
	11	81
	17	17
22217-060000	11	82
22217-120000	7	18
22242-000120	4	33
22252-000220	8	23
22272-000030	12	67
22272-000050	12	73
22351-050010	11	83
22351-060012	4	22
22372-040000	12	83
22512-040120	8	5
22857-500100	4	51
		52
22857-500160	4	53
23065-070225	10	35
23414-080000	10	14
	17	21
23414-120016	12	129
23418-060000	14	29
23857-030000	9	14
23876-005000	4	14
23876-030000	2	9
23887-100002	12	84
24101-060034	11	84
24101-063034	11	85
24104-062010	16	11
24311-000110	18	23
24311-000320	2	31
	4	54
	17	11
24311-000440	18	25
24311-240100	14	10
		16
	18	10
24316-000150	11	56
24341-000070	12	68
24341-000280	12	85
26022-050122	11	87
26022-060162	11	88
26106-050102	11	89
26106-060102	9	9
	12	69
		73 B
		86
26106-060122	2	23
	3	10
	7	9
26106-060142	12	87

Parts No. Index

Parts No.	Fig. No.	Ref. No.
26106-060162	2	24
26106-060202	4	55
	12	88
26106-060252	3	11
26106-060302	10	22
26106-060352	7	14
26106-060402	2	25
		26
26106-060452	3	12
	12	89
26106-060602	2	27
26106-060652	2	28
26106-060752	4	56
26106-080122	10	15
26106-080162	4	2
26106-080202	10	25
	16	20
26106-080402	4	35
26106-080502	10	16
26106-100252	15	1
26106-100452	16	27 -1
26206-100252	3	14
26306-080002	2	29
	6	6
26306-100002	16	17
26577-060122	10	9
26716-060002	11	90
26716-120002	7	19
26736-120002	12	90
26756-060002	12	91
26979-050162	4	34
27241-120000	1	14
27241-250000	10	10
719515-01560	1	1
719515-92640	17	1
719540-51370	11	1
719717-01500	2	5
719717-02900	1	15
719717-02901	1	15 -1
719717-02910	1	35
719717-02911	1	35 -1
977770-1207F	2	32
	3	16
	4	60
	17	25
X0280210331	15	24
X0280335350	15	34
X0280626010	15	13
X0280996180	15	4
X0281007750	15	3

Parts No.	Fig. No.	Ref. No.
X0282005991	15	7
X0283006960	15	8
X0284105040	15	14
X0284525010	15	28
X0285007030	15	11
X0285105190	15	5
X0285205030	15	6
X0286105010	15	16
X0286305010	15	18
X0286355010	15	19
X0287405140	15	20
X0534007800	15	21
X1289510130	15	35
X2A07075KB	16	4
X2A10592KA	16	3
X3A02982KC	16	5
X3A08863KA	16	15
X4284001590	15	9
X4A10092KA	16	6
X9055715000	15	22
X9490065670	15	33
X9490138090	15	26
X9490138100	15	27
X9490138110	15	25
X9490423420	15	31
X9490560750	15	30
X9490562360	15	29
X9490721360	15	23
X9491034320	15	17
X9491034330	15	15
X9491040990	15	12
X9491050100	15	10
XM069000000	16	8
XM219230000	16	13
XM771860000	16	9
XM771870000	16	16
XM860250000	16	14
XM863720000	16	12
XYSPS400800	16	7

Parts No.	Fig. No.	Ref. No.
-----------	----------	----------

Parts No.	Fig. No.	Ref. No.
-----------	----------	----------