

OCD10-M85100EN

PREFACE

1. This Parts Catalog is the 1st edition of 3TNV70-FDW Diesel Engine for Denyo Co., Ltd.

Pub. No. : 000Y00D8510

Published : May.,2005

2. Model name

Engine model	Vehicle		Vehicle made by
	Products	Model name	
3TNV70-FDW	GENERATOR	TLG-12ESX TLG-13ESY	Denyo Co., Ltd.

Contents

Fig. No. Fig. Name

ENGINE (3TNV70-FDW)

1. CYLINDER BLOCK
2. GEAR HOUSING
3. FLYWHEEL HOUSING & OIL SUMP
4. CYLINDER HEAD & BONNET
5. EXHAUST MANIFOLD
6. CAMSHAFT & DRIVING GEAR
7. CRANKSHAFT & PISTON
8. LUB.OIL SYSTEM
9. COOLING WATER SYSTEM
10. FUEL INJECTION PUMP
11. GOVERNOR
12. FUEL INJECTION VALVE
17. (12A)FUEL INJECTION VALVE
13. STARTING MOTOR
14. GENERATOR
15. ELECTLIC PART
16. GASKET SET

Fig. No. Fig. Name

Fig.1. CYLINDER BLOCK

(A)=3TNV70-FDW

(B)=

(C)=

(D)=

(E)=

(F)=

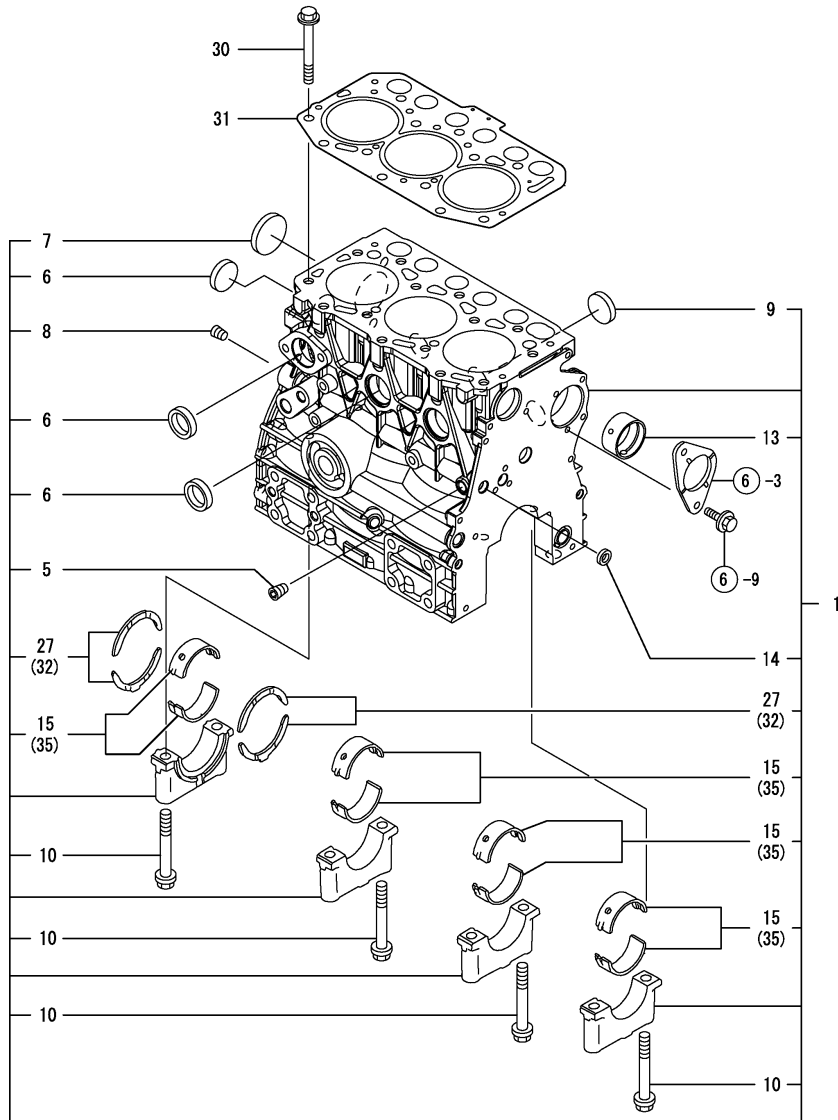

No.	Lev.	Parts No.	Description	Q'ty						I	R
				(A)	(B)	(C)	(D)	(E)	(F)		
1	1	719515-01560	BLOCK ASSY, CYLINDER	1							
5	2	124060-01050	PLUG, PT1/8	1							
6	2	105311-01090	PLUG, 30	4							
7	2	119623-01250	PLUG, 45	1							
8	2	124160-01910	PLUG, PT1/4	1							
9	2	119285-01990	PLUG, 25	3							
10	2	119620-02020	BOLT, METAL CAP	8							
13	2	119717-02410	BUSH, CAMSHAFT	1							
14	2	27241-120000	PLUG, 12	1							
15	2	719717-02900	BEARING, MAIN	4							2
27	2	119717-02930	BEARING, THRUST	2							
30	1	119515-01200	BOLT, HEAD	14							
31	1	119515-01330	GASKET, HEAD	1							
32	1	119810-02940	BEARING, THRUST 0.25	2							1
35	1	719717-02910	BEARING, 0.25 US	4							3

Remarks
 (1) OVER-SIZE(O.S=0.25)PART.
 (2) REPAIR PART.
 (3) UNDER-SIZE(U.S=0.25)PART

Fig.2. GEAR HOUSING

(A)=3TNV70-FDW

(B)=

(C)=

(D)=

(E)=

(F)=

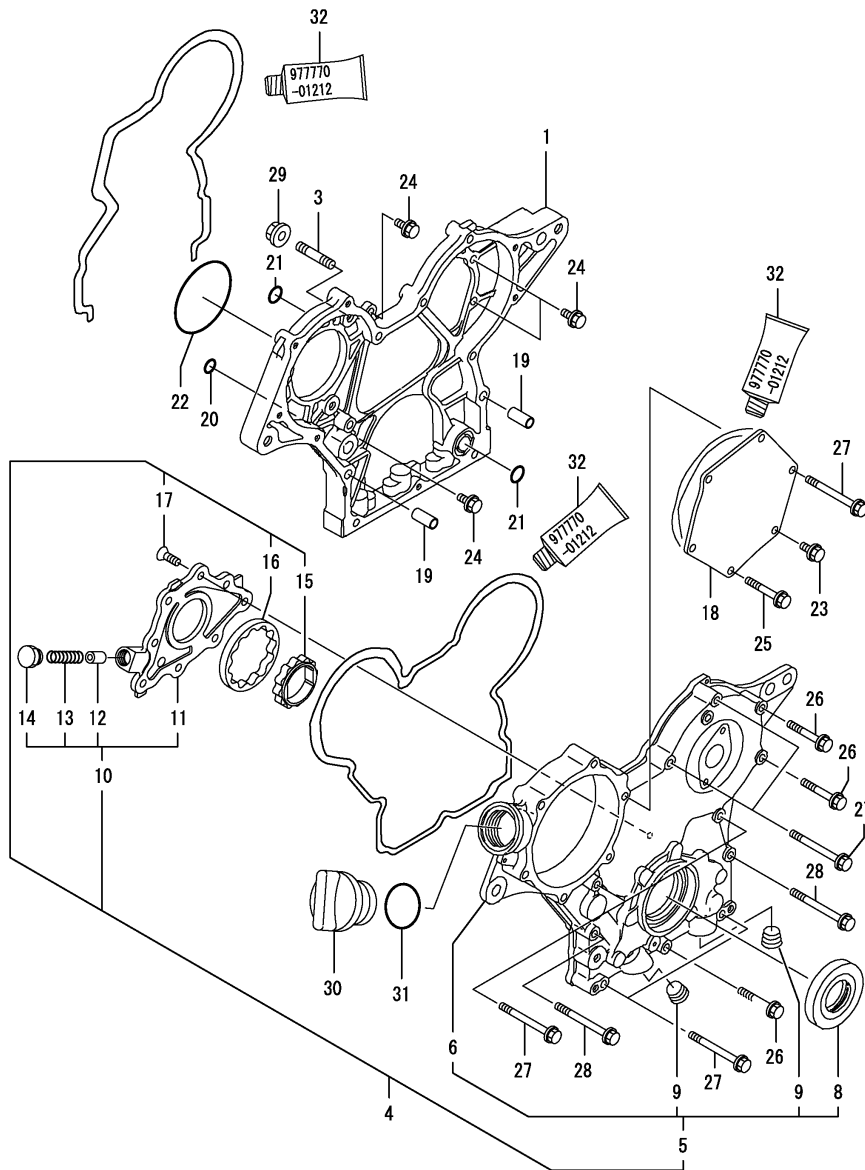

No.	Lev.	Parts No.	Description	Q'ty						I	R
				(A)	(B)	(C)	(D)	(E)	(F)		
1	1	119717-01501	CASE, GEAR	1							
3	1	119717-01570	STUD	3							
4	1	119717-01590	COVER ASSY,GEAR CASE	1							
5	2	719717-01500	COVER ASSY,GEAR CASE	1							
6	3	119717-01521	COVER, GEAR CASE	1							
8	3	119620-01800	SEAL, OIL	1							
9	3	23876-030000	PLUG, R03	2							
10	2	119717-32100	COVER ASSY	1							
11	3	119717-32080	COVER	1							
12	3	129900-32130	VALVE, RELIEF	1							
13	3	129001-32320	SPRING	1							
14	3	129001-32330	PLUG	1							
15	2	119717-32110	ROTOR, INNER	1							
16	2	119717-32120	ROTOR, OUTER	1							
17	2	119802-32130	SCREW, M6X16	8							
18	1	119717-01750	COVER	1							
19	1	119660-01911	PIPE, KNOCK	4							
20	1	119624-32040	O-RING, P12.0	1							
21	1	119717-32050	O-RING, P17.0	3							
22	1	121850-51960	O-RING	1							
23	1	26106-060122	BOLT, M6X 12 PLATED	1							
24	1	26106-060162	BOLT, M6X 16 PLATED	4							
25	1	26106-060402	BOLT, M6X 40 PLATED	4							
26	1	26106-060402	BOLT, M6X 40 PLATED	3							
27	1	26106-060602	BOLT, M6X 60 PLATED	7							
28	1	26106-060652	BOLT, M6X 65 PLATED	2							
29	1	26306-080002	NUT, M8	3							
30	1	124160-01751	COVER, FILLER	1							
31	1	24311-000320	O-RING, 1AP32.0	1							
32	1	977770-01212	GASKET, LIQUID	1							1

Remarks
(1) OPTIONAL PART.

Fig.3. FLYWHEEL HOUSING & OIL SUMP

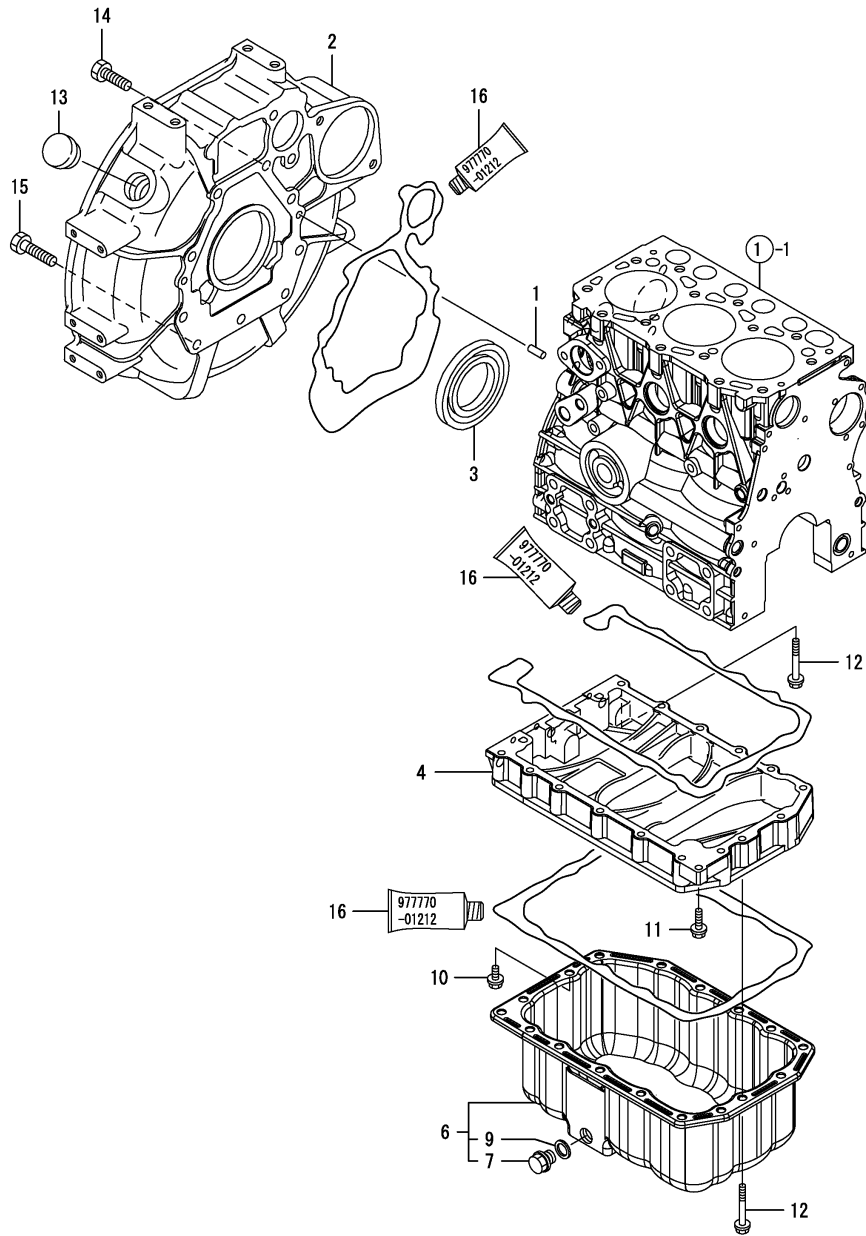

(A)=3TNV70-FDW

(B)=

(C)=

(D)=

(E)=

(F)=

No.	Lev.	Parts No.	Description	Q'ty						I	R
				(A)	(B)	(C)	(D)	(E)	(F)		
1	1	129100-01580	PIN, M8X16	2							
2	1	119717-01601	HOUSING, FLYWHEEL	1							
3	1	124085-02220	SEAL, OIL	1							
4	1	119515-01720	SPACER, OIL SUMP	1							
6	1	119546-01770	SUMP ASSY, OIL	1							
7	2	105425-01690	PLUG, 16	1							
9	2	22190-160002	WASHER, SEAL 16	1							
10	1	26106-060122	BOLT, M6X 12 PLATED	1							
11	1	26106-060252	BOLT, M6X 25 PLATED	1							
12	1	26106-060452	BOLT, M6X 45 PLATED	17							
13	1	119620-01750	CAP	1							
14	1	26206-100252	BOLT, M10X 25 PLATED	8							
15	1	121120-01620	BOLT, M10X28	3							
16	1	977770-01212	GASKET, LIQUID	1							1

Remarks
(1) OPTIONAL PART.

Fig.4. CYLINDER HEAD & BONNET

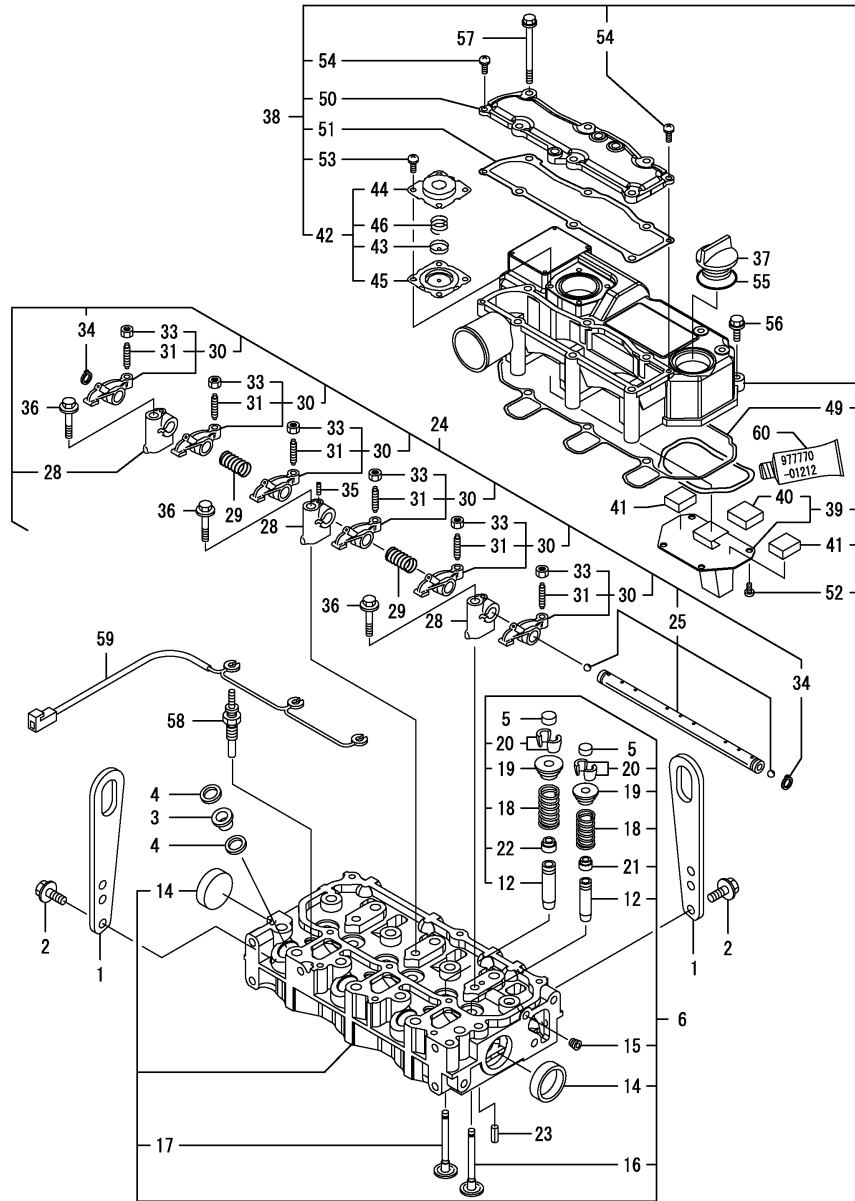

(A)=3TNV70-FDW

(B)=

(C)=

(D)=

(E)=

(F)=

No.	Lev.	Parts No.	Description	Q'ty						I	R
				(A)	(B)	(C)	(D)	(E)	(F)		
1	1	129900-07900	LIFTER	2							
2	1	26106-080162	BOLT, M8X 16 PLATED	4							
3	1	129901-11450	PROTECTOR, NOZZLE	3							
4	1	119600-11460	GASKET, NOZZLE	6							
5	1	105010-11490	CAP, VALVE	6							
6	1	119515-11750	HEAD ASSY, CYLINDER	1							
12	2	119515-11800	GUIDE, VALVE	6							1
14	2	119285-11990	PLUG, 35	2							
15	2	23876-005000	PLUG, R005	1							
16	2	119515-11100	VALVE, INTAKE	3							
17	2	119515-11110	VALVE, EXHAUST	3							
18	2	119717-11131	SPRING, VALVE	6							
19	2	129508-11180	RETAINER, SPRING	6							
20	2	119717-11190	COTTER	12							
21	2	119717-11340	SEAL, VALVE STEM	3							
22	2	119717-11350	SEAL, VALVE STEM	3							
23	1	22351-060012	PIN, SPRING 6.0X12	2							
24	1	119515-11200	SUPPORT ASSY, ARM	1							
25	2	119515-11240	SHAFT ASSY, ROCKER	1							
28	2	119717-11260	SUPPORT, ROCKER ARM	3							
29	2	119515-11280	SPRING	2							
30	2	119717-11650	ARM, ROCKER	6							
31	3	129150-11230	SCREW, VALVE ADJUST	6							
33	3	129150-11750	NUT, M8	6							
34	2	22242-000120	RING, 12	2							
35	2	26979-050162	SCREW, M5X16	1							
36	1	26106-080402	BOLT, M8X 40 PLATED	3							
37	1	124160-01751	COVER, FILLER	1							
38	1	119515-11380	BONNET ASSY, HEAD	1							
39	2	119717-03031	PLATE	1							
40	3	119717-03070	BAFFLE, BREATHER	1							
41	2	119717-03070	BAFFLE, BREATHER	2							
42	2	119802-03100	DIAPHRAGM ASSY	1							
43	3	119802-03110	PLATE	1							
44	3	119802-03121	COVER, DIAPHRAGM	1							
45	3	119802-03131	DIAPHRAGM	1							
46	3	119802-03141	SPRING, DIAPHRAGM	1							
49	2	119515-11310	GASKET, BONNET	1							
50	2	119515-11320	COVER, BONNET	1							
51	2	119515-11330	GASKET	1							
52	2	22857-500100	SCREW, 5X10	4							
53	2	22857-500100	SCREW, 5X10	4							
54	2	22857-500160	SCREW, 5X16	2							
55	1	24311-000320	O-RING, 1AP32.0	1							
56	1	26106-060202	BOLT, M6X 20 PLATED	3							
57	1	26106-060752	BOLT, M6X 75 PLATED	6							
58	1	119717-77800	PLUG, GLOW	3							
59	1	119717-77820	CONNECTOR, GLOW PLUG	1							
60	1	97770-01212	GASKET, LIQUID	1							2

Remarks
 (1) REPAIR PART.
 (2) OPTIONAL PART.

Fig.5. EXHAUST MANIFOLD

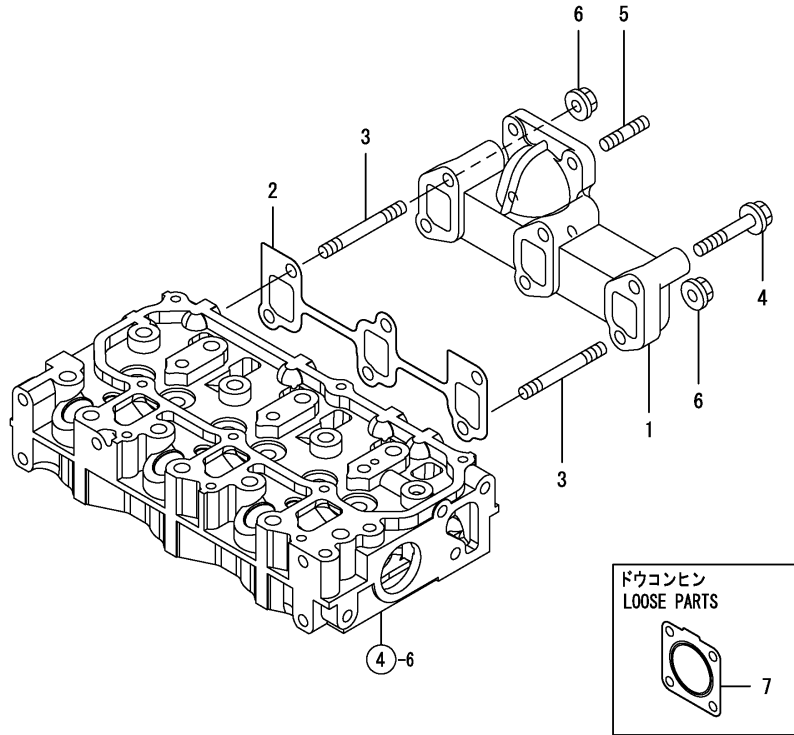

(A)=3TNV70-FDW
(B)=
(C)=

(D)=
(E)=
(F)=

No.	Lev.	Parts No.	Description	Q'ty						I	R
				(A)	(B)	(C)	(D)	(E)	(F)		
1	1	119718-13100	MANIFOLD, EXHAUST	1							
2	1	119717-13110	GASKET	1							
3	1	119717-13600	STUD, M8X50	2							
4	1	119802-13620	BOLT, M8X50	4							
5	1	119131-18320	STUD, M8X22	4							
6	1	26306-080002	NUT, M8	2							
7	1	119515-13200	GASKET, SILENCER	1							

Fig.6. CAMSHAFT & DRIVING GEAR

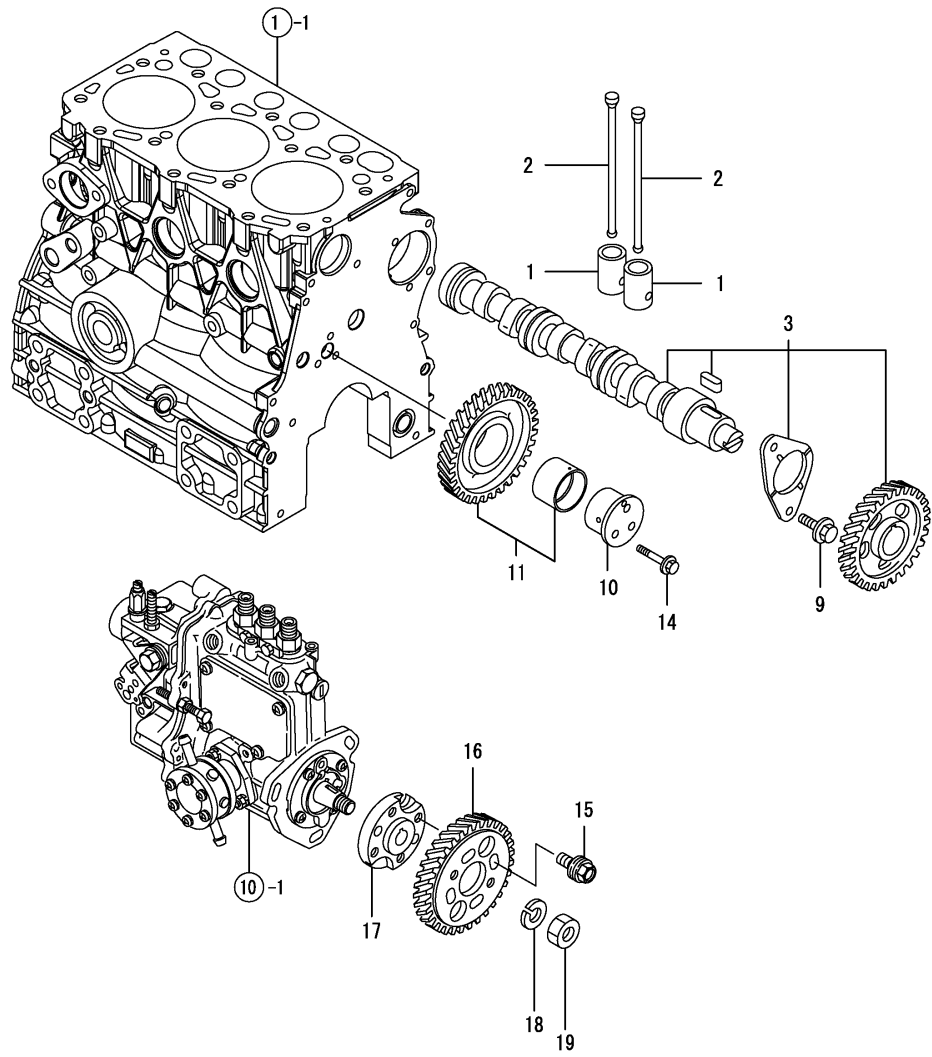

(A)=3TNV70-FDW
(B)=
(C)=

(D)=
(E)=
(F)=

No.	Lev.	Parts No.	Description	Q'ty						I	R
				(A)	(B)	(C)	(D)	(E)	(F)		
1	1	119620-14200	TAPPET	6							
2	1	119515-14400	ROD, PUSH	6							
3	1	119515-14580	CAMSHAFT ASSY	1							
9	1	26106-060122	BOLT, M6X 12 PLATED	2							
10	1	119717-25050	SHAFT, IDLE	1							
11	1	119717-25100	GEAR ASSY, IDLE	1							
14	1	26106-060352	BOLT, M6X 35 PLATED	3							
15	1	129150-25301	BOLT	4							
16	1	119717-25930	GEAR, PUMP	1							
17	1	119717-51150	FLANGE	1							
18	1	22217-120000	WASHER, SPRING 12	1							
19	1	26716-120002	NUT, M12	1							

Fig.7. CRANKSHAFT & PISTON

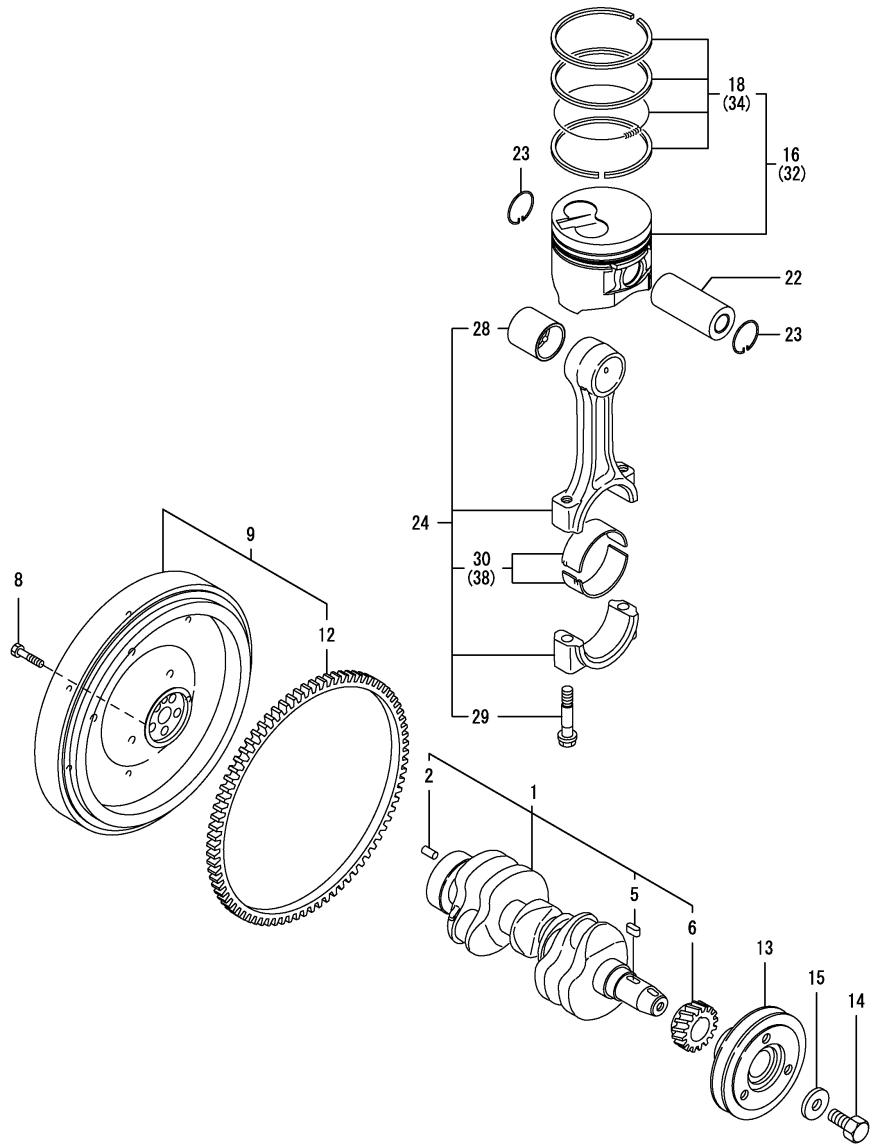

(A)=3TNV70-FDW

(B)=

(C)=

(D)=

(E)=

(F)=

No.	Lev.	Parts No.	Description	Q'ty						I	R
				(A)	(B)	(C)	(D)	(E)	(F)		
1	1	119515-21700	CRANKSHAFT ASSY	1							
2	2	129100-01580	PIN, M8X16	1							
5	2	22512-040120	KEY, 4X 12	1							
6	2	119717-21200	GEAR, CRANKSHAFT	1							
8	1	121111-21501	BOLT, FLYWHEEL	5							
9	1	119546-21590	FLYWHEEL ASSY	1							
12	2	119865-21600	GEAR, RING	1							
13	1	119717-21650	V-PULLEY	1							
14	1	119621-21680	BOLT, FLANGE 12X1.25	1							
15	1	119620-21941	WASHER	1							
16	1	119515-22080	PISTON ASSY	3							
18	2	119515-22500	RING SET, PISTON	3							
22	1	119515-22300	PIN, PISTON	3							
23	1	22252-000220	RING, 22	6							
24	1	119515-23000	ROD ASSY, CONNECTING	3							
28	2	119717-23910	BEARING, PISTON PIN	3							2
29	2	119717-23200	BOLT, CONNECTING ROD	6							
30	2	119515-23600	BEARING, CRANK PIN	3							
32	1	119515-22900	PISTON ASSY, 0.25 OS	3							1
34	2	119515-22550	RING SET, 0.25 OS	3							1
38	1	119515-23610	METAL ASSY, 0.25	3							3

Remarks

- (1) OVER-SIZE(O.S=0.25)PART.
- (2) REPAIR PART.
- (3) UNDER-SIZE(U.S=0.25)PART.

Fig.8. LUB.OIL SYSTEM

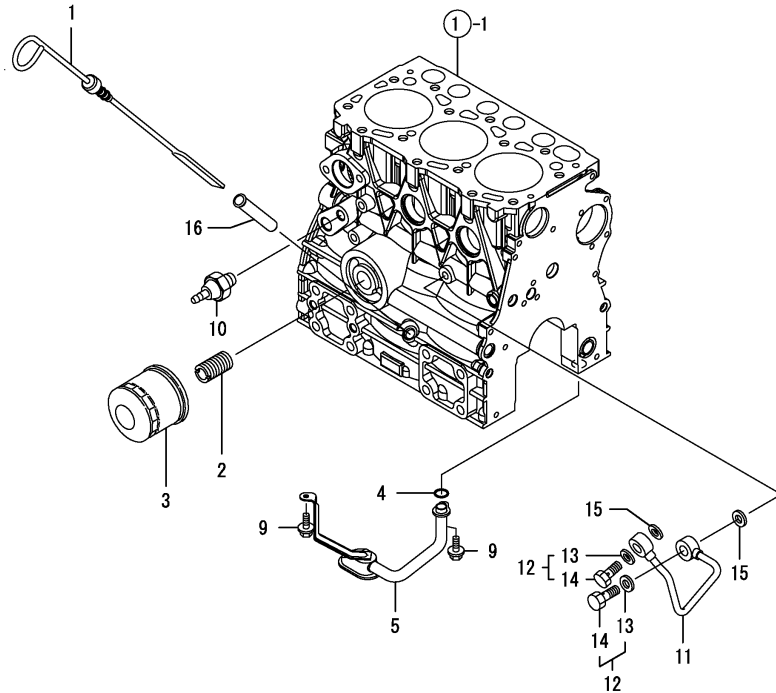

(A)=3TNV70-FDW

(B)=

(C)=

(D)=

(E)=

(F)=

No.	Lev.	Parts No.	Description	Q'ty						I	R
				(A)	(B)	(C)	(D)	(E)	(F)		
1	1	119802-34802	DIPSTICK, OIL	1							
2	1	129100-35140	STUD	1							
3	1	119305-35151	FILTER ASSY, D68XL65	1							1
4	1	119717-32060	O-RING, P15.0	1							
5	1	119546-35080	PIPE ASSY, OIL INLET	1							
9	1	26106-060102	BOLT, M6X 10 PLATED	2							
10	1	114250-39450	SWITCH, 0.5KG	1							
11	1	119717-39210	PIPE, OIL	1							
12	1	129005-59830	BOLT ASSY, JOINT M8	2							
13	2	22190-080002	WASHER, SEAL 6	2							
14	2	23857-030000	BOLT, JOINT 3	2							
15	1	22190-080002	WASHER, SEAL 6	2							
16	1	121520-34810	GUIDE, DIPSTICK	1							

Remarks
(1) REPAIR PART.

Fig.9. COOLING WATER SYSTEM

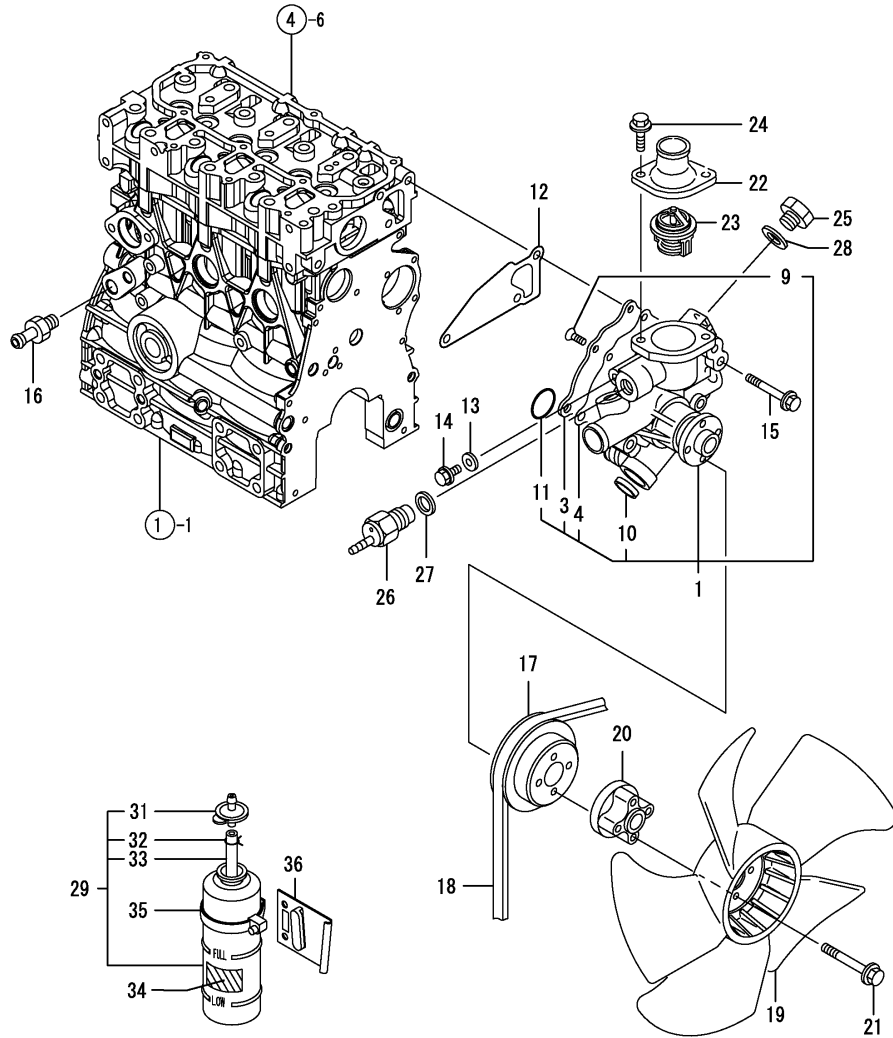

(A)=3TNV70-FDW

(B)=

(C)=

(D)=

(E)=

(F)=

No.	Lev.	Parts No.	Description	Q'ty						I	R
				(A)	(B)	(C)	(D)	(E)	(F)		
1	1	119515-42001	PUMP ASSY, WATER	1							
1-1	1	119515-42002	PUMP ASSY, CW	1							N
(A=E/ 85945)											
3	2	119515-42041	COVER	1							
4	2	119717-42031	GASKET	1							
9	2	26577-060122	SCREW, M6X12	4							
10	2	27241-250000	PLUG, 25	1							
11	2	119717-42320	O-RING, P26	1							
11-1	2	119C10-42320	O-RING, 2028	1							S
(A=E/ 85945)											
12	1	119515-42020	GASKET, WATER PUMP	1							
13	1	23414-080000	GASKET, 8X1.0	1							
14	1	26106-080122	BOLT, M8X 12 PLATED	1							
15	1	26106-080502	BOLT, M8X 50 PLATED	3							
16	1	121550-49111	JOINT, PT1/4	1							
17	1	119515-42350	V-PULLEY, D=110	1							
18	1	129612-42340	V-BELT, A36	1							
19	1	119415-44740	FAN, COOLING D=260VC	1							
20	1	129457-44760	SPACER, FAN	1							
21	1	26106-060452	BOLT, M6X 45 PLATED	4							
22	1	129350-49530	COVER, THERMOSTAT	1							
23	1	119717-49800	THERMOSTAT, 71	1							
24	1	26106-080202	BOLT, M8X 20 PLATED	2							
25	1	121450-42450	PLUG, M16	1							
26	1	121250-44901	SWITCH, 110	1							
27	1	124465-44950	GASKET, 16	1							
28	1	124465-44950	GASKET, 16	1							
29	1	124450-44510	TANK ASSY, SUB	1							
31	2	124450-44530	CAP	1							
32	2	124450-44560	RETAINER	1							
33	2	23061-070230	PIPE, 7X 230	1							
34	1	121470-44540	LABEL, SUB-TANK	1							
35	1	124450-44550	BAND	1							
36	1	121256-44600	BRACKET, SUB TANK	1							

Fig.10. FUEL INJECTION PUMP

(A)=3TNV70-FDW

(B)=

(C)=

(D)=

(E)=

(F)=

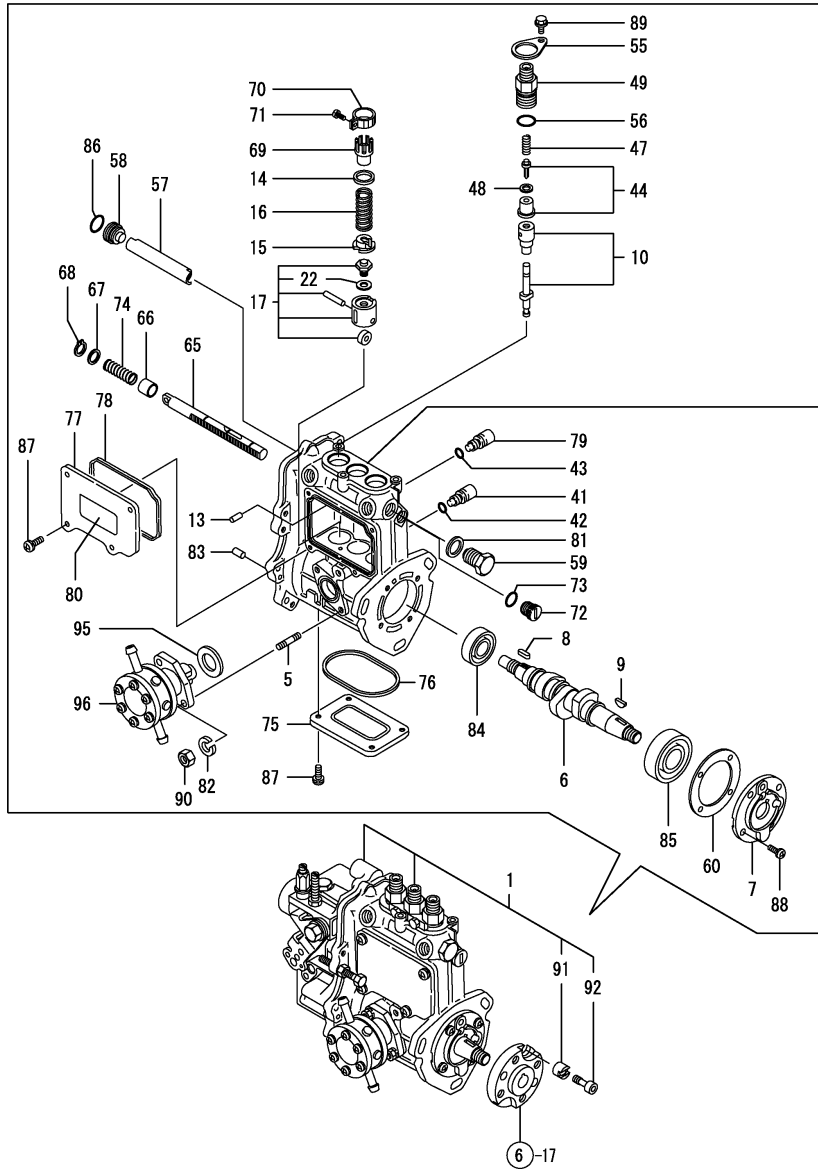

No.	Lev.	Parts No.	Description	Q'ty						I	R
				(A)	(B)	(C)	(D)	(E)	(F)		
1	1	719546-51380	PUMP ASSY, INJECTION	1							1
5	2	129155-51020	STUD	2							
6	2	119717-51030	CAMSHAFT	1							
7	2	119717-51060	SUPPORT, CAMSHAFT	1							
8	2	119717-51070	KEY	1							
9	2	122710-51090	KEY	1							
10	2	119415-51100	PLUNGER ASSY	3							
13	2	129155-51140	PIN	3							
14	2	158600-51170	RETAINER, SPRING	3							
15	2	119717-51180	RETAINER, SPRING	3							
16	2	119717-51190	SPRING, PLUNGER	3							
17	2	119717-51200	TAPPET ASSY	3							
22	3	129155-51600	SHIM SET, ADJUSTING	1							
41	2	158600-51270	STOPPER, TAPPET	3							
42	2	129155-51280	O-RING, S6	3							
43	2	129155-51280	O-RING, S6	1							
44	2	119717-51300	VALVE ASSY, DELIVERY	3							
47	2	119717-51330	SPRING, DELIVERY	3							
48	2	124550-51350	GASKET, DELIVERY	3							
49	2	158600-51441	VALVE ASSY, DELIVERY	3							
55	2	118400-51370	LOCKING	3							
56	2	24316-000150	O-RING, 4DP15.0	3							
57	2	129155-51400	DEFLECTOR	1							
58	2	158600-51410	PLUG, DEFLECTOR	1							
59	2	158600-51420	PLUG, DEFLECTOR	1							
60	2	129155-51450	SHIM SET, ADJUSTING	1							
65	2	119717-51500	RACK, CONTROL	1							
66	2	129155-51521	BUSH, RACK	1							
67	2	129155-51530	SPACER	1							
68	2	129155-51540	CIRCLIP	1							
69	2	129155-51550	PINION, CONTROL	3							
70	2	129100-51560	PINION	3							
71	2	129100-51570	SCREW	3							
72	2	158600-51570	PLUG	1							
73	2	129155-51580	O-RING	1							
74	2	129155-51591	SPRING, RACK	1							
75	2	129155-51701	COVER	1							
76	2	119717-51710	GASKET	1							
77	2	119717-51750	COVER	1							
78	2	119717-51760	GASKET	1							
79	2	158600-51790	STOOPER, RACK	1							
80	2	129156-51910	LABEL, CAUTION	1							
81	2	22190-160002	WASHER, SEAL 16	1							
82	2	22217-060000	WASHER, SPRING 6	2							
83	2	22351-050010	PIN, SPRING 5.0X10	2							
84	2	24101-060034	BEARING, BALL 6003	1							
85	2	24101-063034	BEARING, BALL 6303	1							
86	2	119717-51420	O-RING	1							
87	2	26022-050122	SCREW, M5X12	8							
88	2	26022-060162	SCREW, M6X16	4							
89	2	26106-050102	BOLT, M5X 10 PLATED	3							

Remarks
 (1) GOVERNOR ASSY(FIG.11) IS
 INCORPORATED IN THIS FOP.CMP
 (REF.NO.1).

Fig.10. FUEL INJECTION PUMP

(A)=3TNV70-FDW

(B)=

(C)=

(D)=

(E)=

(F)=

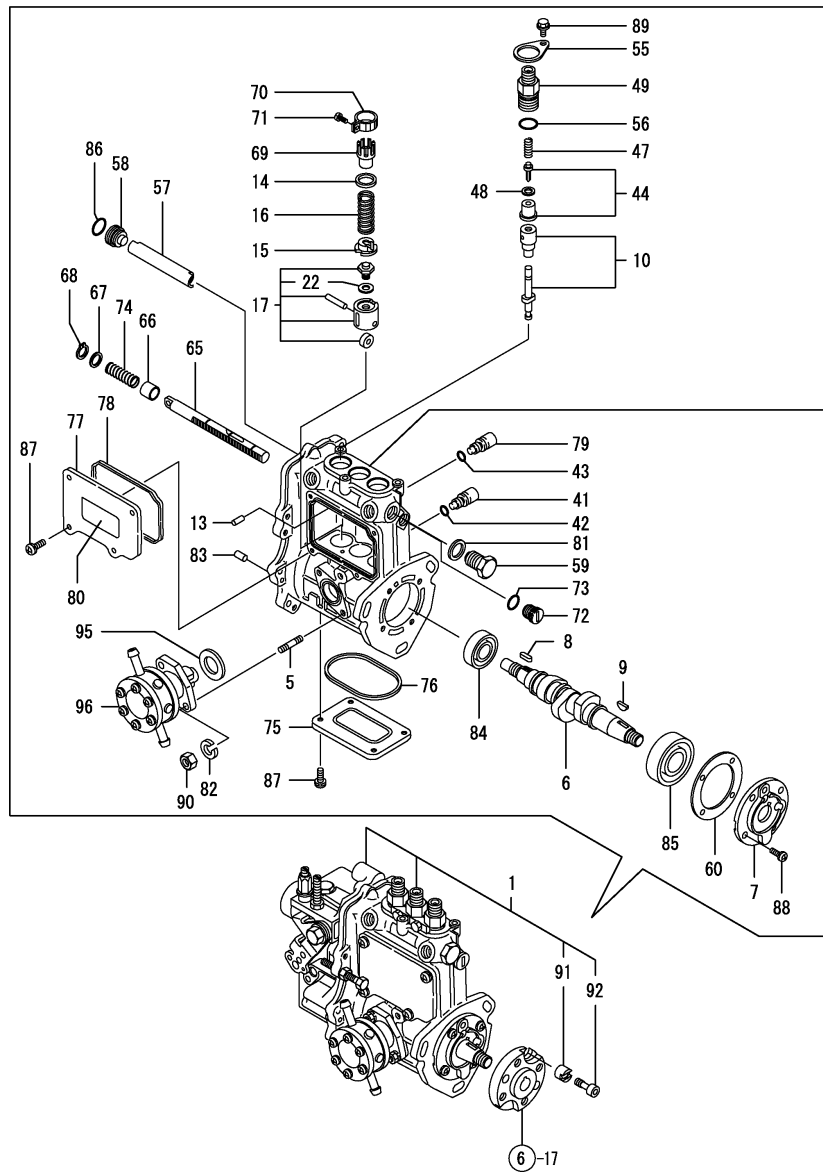

No.	Lev.	Parts No.	Description	Q'ty						I	R
				(A)	(B)	(C)	(D)	(E)	(F)		
90	2	26716-060002	NUT, M6	2							
91	2	119717-51480	COLLAR	1							
92	2	119717-51490	BOLT	1							
95	2	129155-52051	GASKET	1							
96	2	129100-52101	PUMP ASSY, FUEL FEED	1							

Remarks
 (1) GOVERNOR ASSY(FIG.11) IS
 INCORPORATED IN THIS FOP.CMP
 (REF.NO.1).

Fig.11. GOVERNOR

(A)=3TNV70-FDW

(B)=

(C)=

(D)=

(E)=

(F)=

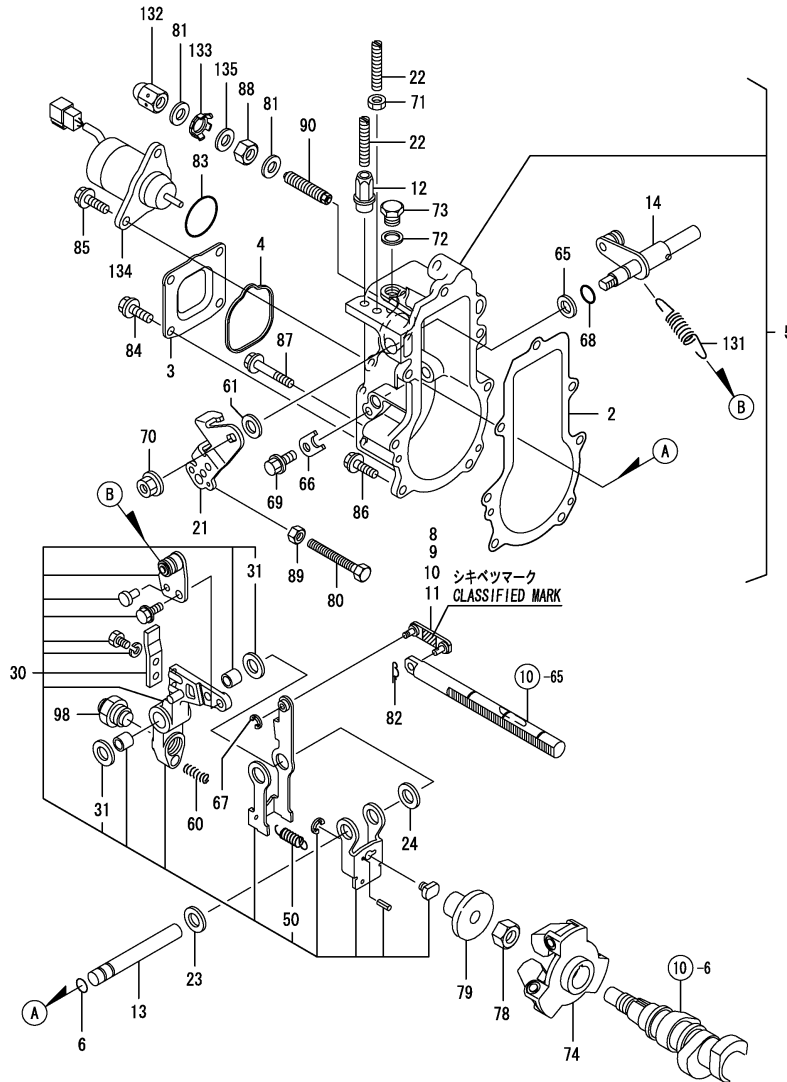

No.	Lev.	Parts No.	Description	Q'ty						I	R
				(A)	(B)	(C)	(D)	(E)	(F)		
2	2	119717-61050	GASKET	1							
3	2	119717-61060	COVER, GOVERNOR CASE	1							
4	2	119717-61070	GASKET	1							
5	2	119742-61100	CASE ASSY, GOVERNOR	1							
6	3	129155-51280	O-RING, S6	1							
8	3	119717-61120	LINK, MARK :3	1							1
9	3	119717-61130	LINK, MARK 98	1							1
10	3	119717-61140	LINK, MARK 88	1							1
11	3	119717-61150	LINK, MARK 03	1							1
12	3	129209-61370	NUT, M6	1							
13	3	129052-61390	SHAFT	1							
14	3	119717-61400	SHAFT ASSY	1							
21	3	119515-61440	LEVER, CONTROL	1							
22	3	129155-61450	BOLT, LIMITER	2							
23	3	129156-61460	SHIM, T=0.6	1							
24	3	129155-61480	SPACER ASSY	1							
30	3	119717-61500	LEVER ASSY, GOVERNOR	1							
31	4	174307-51700	SHIM SET	2							
50	4	129486-61540	SPRING, SET	1							
60	3	129100-61650	SPRING, CONTROLLER	1							
61	3	158552-61700	SHIM SET	1							
65	3	158552-61710	SHIM, T=1.0	1							
66	3	119660-61901	RETAINER, SHAFT	1							
67	3	22272-000030	RING, E- 3	1							
68	3	24341-000070	O-RING, 1AS7.0	1							
69	3	26106-060102	BOLT, M6X 10 PLATED	1							
70	3	26366-080002	NUT, M8	1							
71	3	26756-060002	NUT, LOCK M6	1							
72	2	22190-100002	WASHER, SEAL 10	1							
73	2	23887-100002	PLUG, 10	1							
74	2	119717-61200	WEIGHT ASSY,GOVERNOR	1							
78	2	119660-61300	NUT	1							
79	2	129155-61341	SLEEVE	1							
80	2	129155-61460	BOLT, IDLE	1							
81	2	22190-120002	WASHER, SEAL 12	2							
82	2	22372-040000	PIN, SNAP 4	1							
83	2	24341-000280	O-RING, 1AS28.0	1							
83-1	2	158552-61900	O-RING	1							N
(A=EXXXXX)											
84	2	26106-060102	BOLT, M6X 10 PLATED	4							
85	2	26106-060142	BOLT, M6X 14 PLATED	2							
86	2	26106-060202	BOLT, M6X 20 PLATED	4							
87	2	26106-060452	BOLT, M6X 45 PLATED	3							
88	2	26736-120002	NUT, M12	1							
89	2	26756-060002	NUT, LOCK M6	1							
90	2	158601-61700	LIMITER ASSY, FUEL	1							
98	2	119761-61560	ANGLEICH ASSY	1							
131	2	129573-61700	SPRING, GOVERNOR	1							
132	2	129209-61930	NUT, CAP	1							
133	2	129209-61970	PLATE	1							
134	2	119233-77932	SOLENOID, STOP	1							

Remarks

(1) SELECTIVE PARTS: CERTAIN THE CLASSIFICATION MARK, THEN PLACE YOUR ORDER.(REF. TO ILLUSTRATION)
 * THIS FIGURE(GOVERNOR ASSY)IS INCORPORATED IN THE FUEL INJECTION PUMP ASSY(FIG.10).

Fig.11. GOVERNOR

(A)=3TNV70-FDW

(B)=

(C)=

(D)=

(E)=

(F)=

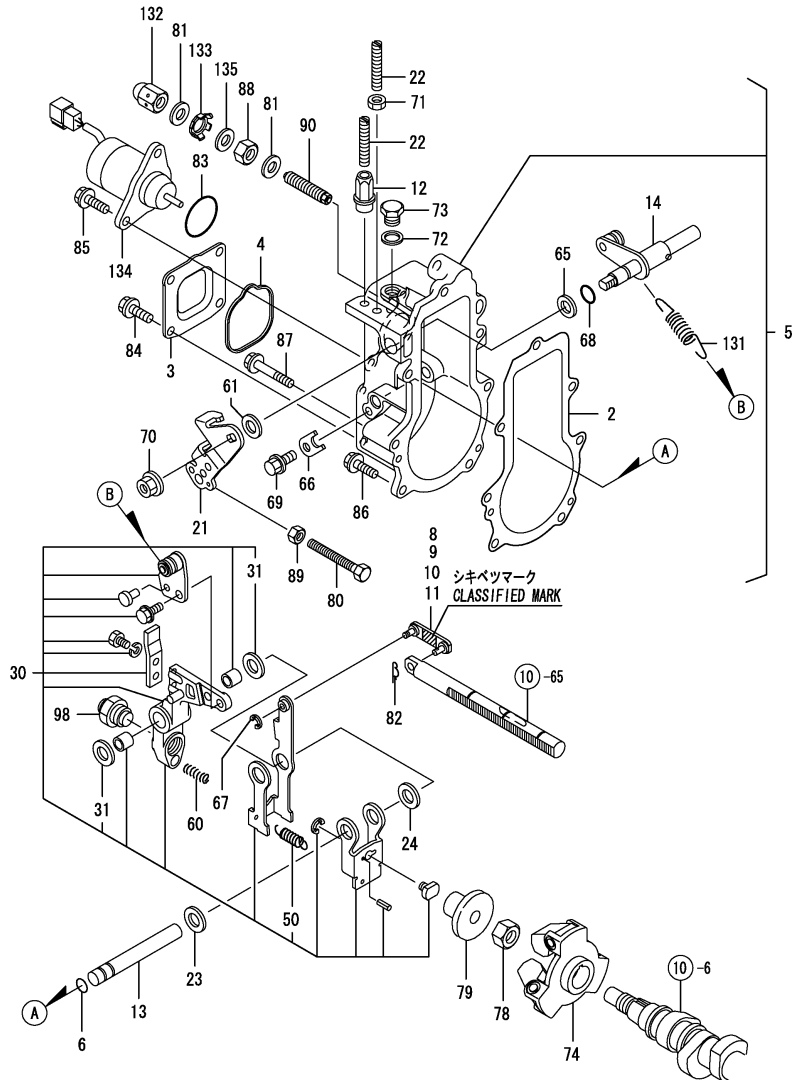

No.	Lev.	Parts No.	Description	Q'ty						I	R
				(A)	(B)	(C)	(D)	(E)	(F)		
135	2	23414-120016	GASKET, 12X1.0	1							

Remarks

(1) SELECTIVE PARTS: CERTAIN THE CLASSIFICATION MARK, THEN PLACE YOUR ORDER.(REF. TO ILLUSTRATION)
 * THIS FIGURE(GOVERNOR ASSY)IS INCORPORATED IN THE FUEL INJECTION PUMP ASSY(FIG.10).

Fig.12. FUEL INJECTION VALVE

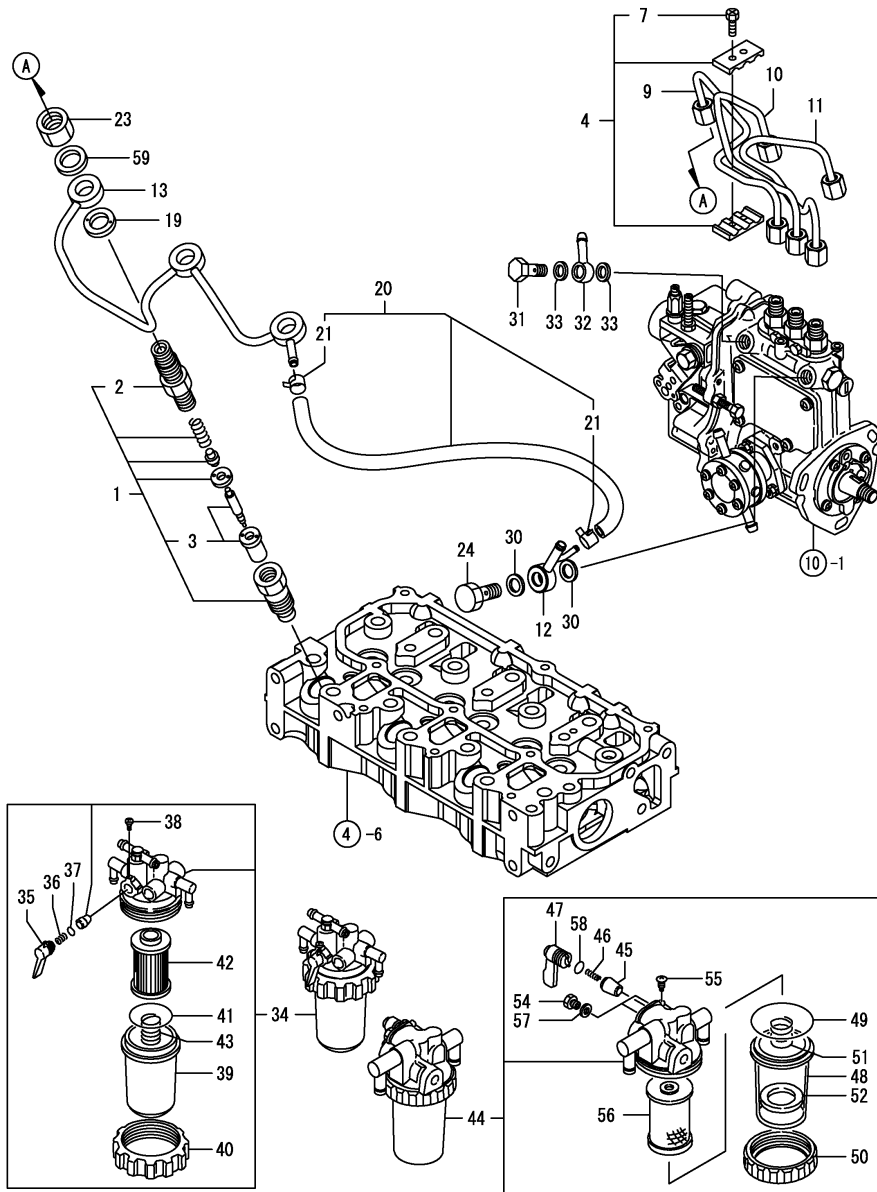

(A)=3TNV70-FDW

(B)=

(C)=

(D)=

(E)=

(F)=

No.	Lev.	Parts No.	Description	Q'ty						I	R
				(A)	(B)	(C)	(D)	(E)	(F)		
1	1	119515-53001	VALVE ASSY,INJECTION	3							
2	2	118200-53010	HOLDER, NOZZLE	3							
3	2	119515-53010	VALVE ASSY,INJECTION	3							
4	1	129150-59120	RETAINER, PIPE	1							
7	2	129150-59131	BOLT, M4X14	2							
9	1	119546-59810	PIPE ASSY, INJECTION	1							
10	1	119546-59820	PIPE ASSY, INJECTION	1							
11	1	119546-59830	PIPE ASSY, INJECTION	1							
12	1	119840-59570	JOINT	1							
13	1	119515-59540	PIPE ASSY, RETURN	1							
19	1	129901-59560	GASKET	3							
20	1	119540-59570	PIPE ASSY, RETURN	1							
21	2	124066-59100	CLIP, HOSE 8	2							
23	1	119620-59700	NUT, NOZZLE	3							
24	1	119813-59950	VALVE ASSY, CHECK	1							
30	1	22190-120002	WASHER, SEAL 12	2							
31	1	103854-39140	BOLT, PIPE JOINT	1							
32	1	101304-59020	JOINT, PIPE 12	1							
33	1	22190-120002	WASHER, SEAL 12	2							
34	1	119833-55620	FILTER ASSY, FUEL	1							
35	2	119810-55340	LEVER	1							
36	2	104200-55330	SPRING, VALVE	1							
37	2	24311-240100	O-RING, 1AP10A	1							
38	2	104200-55750	SCREW, M4	1							
39	2	121254-55510	COVER	1							
40	2	110250-55610	RING, RETAINING	1							
41	2	102103-55520	O-RING	1							
42	2	119810-55650	ELEMENT	1							
43	2	121250-55620	SPRING	1							
44	1	129335-55700	SEPARATOR ASSY,WATER	1							
45	2	104200-55321	VALVE, TAPER	1							
46	2	104200-55330	SPRING, VALVE	1							
47	2	104200-55341	HANDLE	1							
48	2	124064-55510	COVER	1							
49	2	102103-55520	O-RING	1							
50	2	110250-55610	RING, RETAINING	1							
51	2	121257-55720	SPRING	1							
52	2	121257-55731	FLOAT	1							
54	2	101720-55750	PLUG, 6	2							
55	2	104200-55750	SCREW, M4	1							
56	2	171081-55910	SCREEN	1							
57	2	23418-060000	GASKET, 6X1.0	2							
58	2	24311-240100	O-RING, 1AP10A	1							
59	1	22190-120002	WASHER, SEAL 12	3							

Remarks

*This item is applicable to [(A)=EZZZZ-1] or previous machines. Refer to Fig.18.

Fig.17. (12A)FUEL INJECTION VALVE

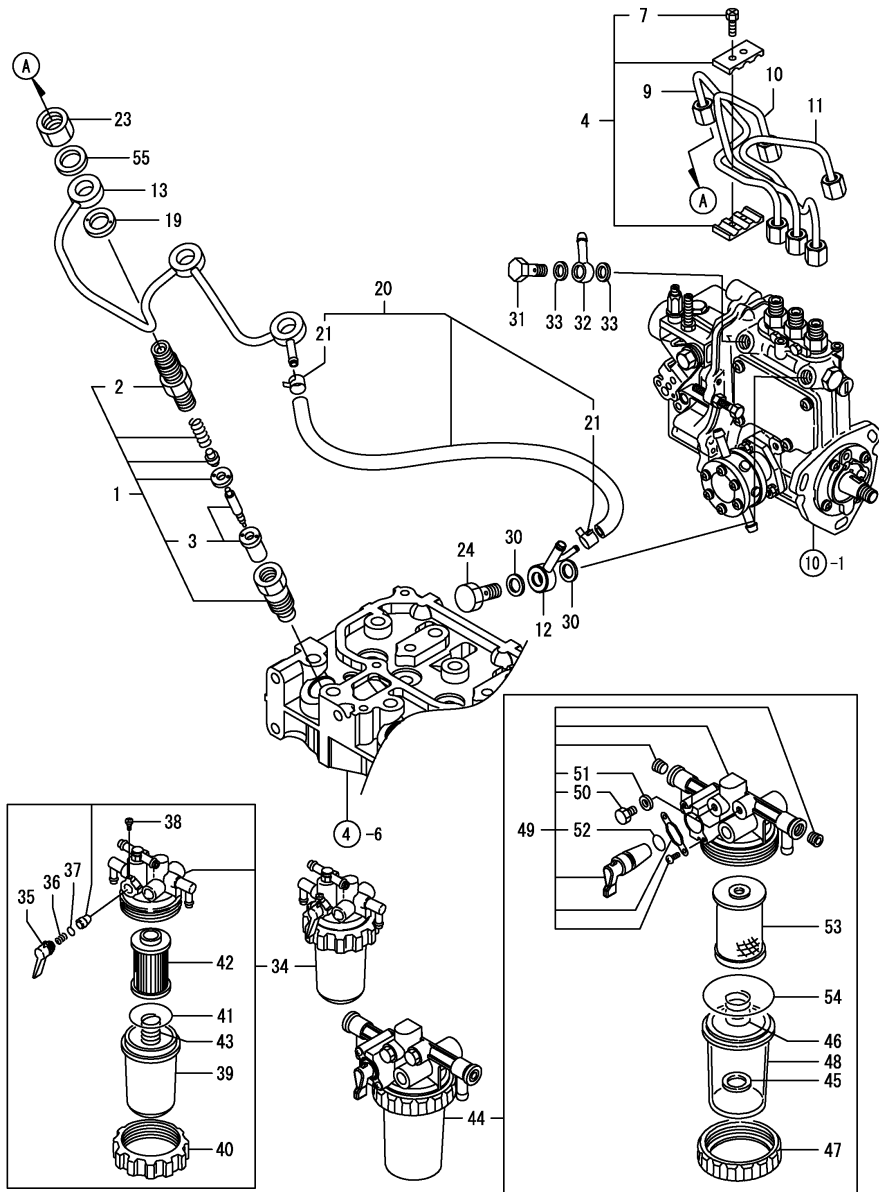

(A)=3TNV70-FDW

(B)=

(C)=

(D)=

(E)=

(F)=

No.	Lev.	Parts No.	Description	Qty						I	R
				(A)	(B)	(C)	(D)	(E)	(F)		
1	1	119515-53001	VALVE ASSY,INJECTION	3							
2	2	118200-53010	HOLDER, NOZZLE	3							
3	2	119515-53010	VALVE ASSY,INJECTION	3							
4	1	129150-59120	RETAINER, PIPE	1							
7	2	129150-59131	BOLT, M4X14	2							
9	1	119546-59810	PIPE ASSY, INJECTION	1							
10	1	119546-59820	PIPE ASSY, INJECTION	1							
11	1	119546-59830	PIPE ASSY, INJECTION	1							
12	1	119840-59570	JOINT	1							
13	1	119515-59540	PIPE ASSY, RETURN	1							
19	1	129901-59560	GASKET	3							
20	1	119540-59570	PIPE ASSY, RETURN	1							
21	2	124066-59100	CLIP, HOSE 8	2							
23	1	119620-59700	NUT, NOZZLE	3							
24	1	119813-59950	VALVE ASSY, CHECK	1							
30	1	22190-120002	WASHER, SEAL 12	2							
31	1	103854-39140	BOLT, PIPE JOINT	1							
32	1	101304-59020	JOINT, PIPE 12	1							
33	1	22190-120002	WASHER, SEAL 12	2							
34	1	119833-55620	FILTER ASSY, FUEL	1							
35	2	119810-55340	LEVER	1							
36	2	104200-55330	SPRING, VALVE	1							
37	2	24311-240100	O-RING, 1AP10A	1							
38	2	104200-55750	SCREW, M4	1							
39	2	121254-55510	COVER	1							
40	2	110250-55610	RING, RETAINING	1							
41	2	102103-55520	O-RING	1							
42	2	119810-55650	ELEMENT	1							
43	2	121250-55620	SPRING	1							
44	1	129335-55750	SEPARATOR ASSY,WATER	1							
45	2	129053-55640	FLOAT	1							
46	2	129053-55650	SPRING, SCREEN	1							
47	2	119833-55660	RING, RETAINING	1							
48	2	129335-55740	CUP	1							
49	2	129335-55770	BODY ASSY	1							
50	3	129242-55750	VALVE, AIR VENT	2							
51	3	129242-55760	GASKET	2							
52	3	24311-000110	O-RING, 1AP11.0	1							
53	2	129335-55780	ELEMENT ASSY	1							
54	2	24311-000440	O-RING, 1AP44.0	1							
55	1	22190-120002	WASHER, SEAL 12	3							

Remarks
 *This item is applicable to
 [(A)=EZZZZZ] or following
 machines. Refer to Fig.12.

Fig.13. STARTING MOTOR

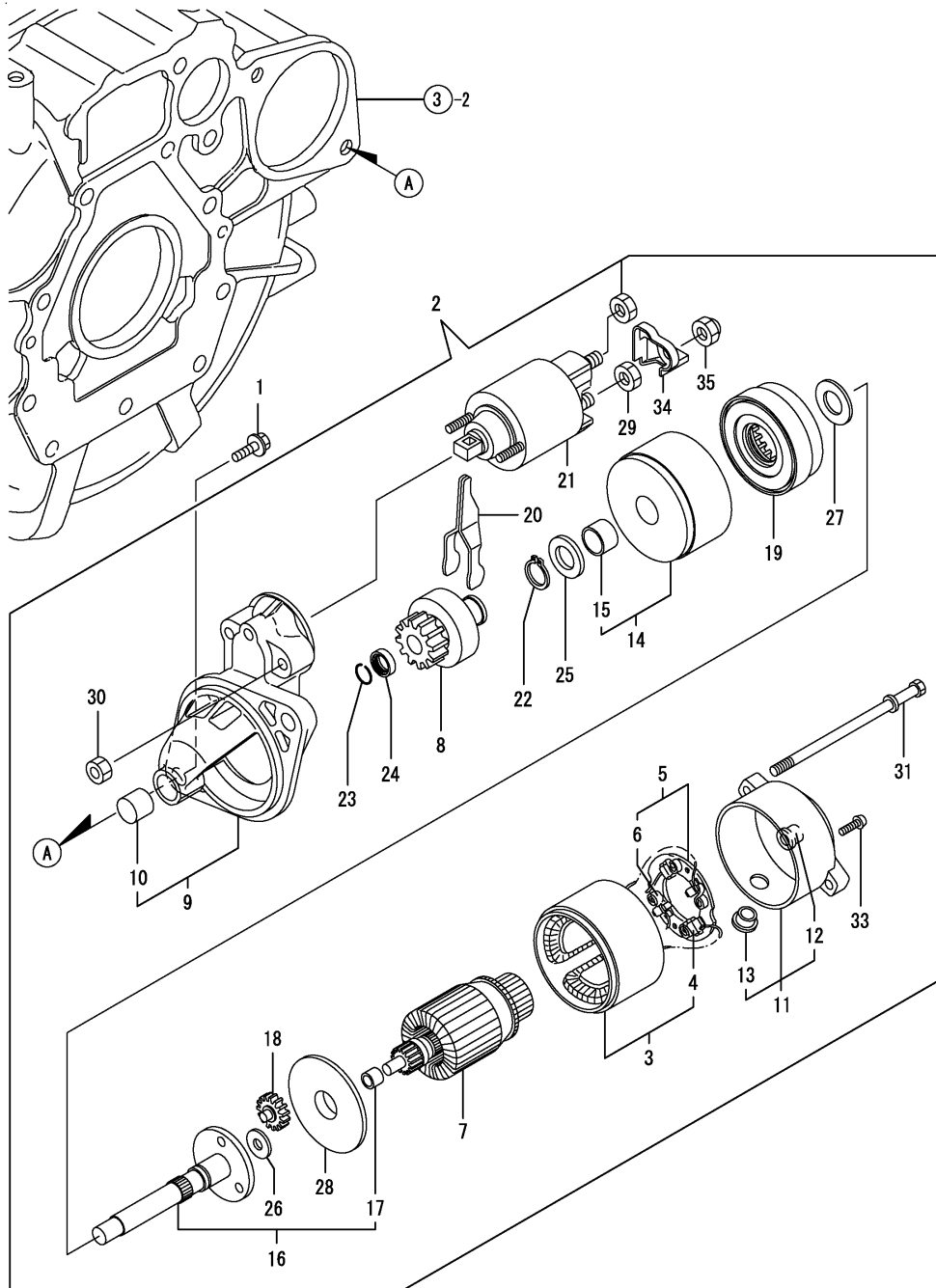

(A)=3TNV70-FDW

(B)=

(C)=

(D)=

(E)=

(F)=

No.	Lev.	Parts No.	Description	Q'ty						I	R
				(A)	(B)	(C)	(D)	(E)	(F)		
1	1	26106-100252	BOLT, M10X 25 PLATED	2							
2	1	119515-77010	STARTER	1							
3	2	X0281007680	YOKE ASSY	1							
4	3	X0280996180	STARTER KIT	2							
5	2	X0285105190	HOLDER ASSY	1							
6	3	X0285205030	SPRING	4							
7	2	X0282005871	ARMATURE ASSY	1							
8	2	X0283006960	CLUTCH ASSY	1							
9	2	X4284001590	HOUSING ASSY	1							
10	3	X9491050100	BEARING, NEEDLE	1							
11	2	X0285007030	FRAME ASSY	1							
12	3	X9491040990	BEARING	1							
13	3	X0280626010	COVER	1							
14	2	X0284105040	BEARING ASSY	1							
15	3	X9491034330	BEARING	1							
16	2	X0286105010	SHAFT ASSY	1							
17	3	X9491034320	BEARING	1							
18	2	X0286305010	GEAR	3							
19	2	X0286355010	GEAR	1							
20	2	X0287405140	LEVER	1							
21	2	X0534007800	SWITCH ASSY	1							
22	2	X9055715000	RING	1							
23	2	X9490721360	RING	1							
24	2	X0280210331	NUT	1							
25	2	X9490138110	WASHER	1							
26	2	X9490138090	WASHER	1							
27	2	X9490138100	WASHER	1							
28	2	X0284525010	PLATE	1							
29	2	X9490562360	NUT	1							
30	2	X9490560750	NUT	2							
31	2	X9490423520	BOLT, THROUGH	2							
33	2	X9490065670	SCREW, M4X6	2							
34	2	X0280335360	COVER, TERMINAL	1							
35	2	X1289510130	NUT	1							

Fig.14. GENERATOR

(A)=3TNV70-FDW

(B)=

(C)=

(D)=

(E)=

(F)=

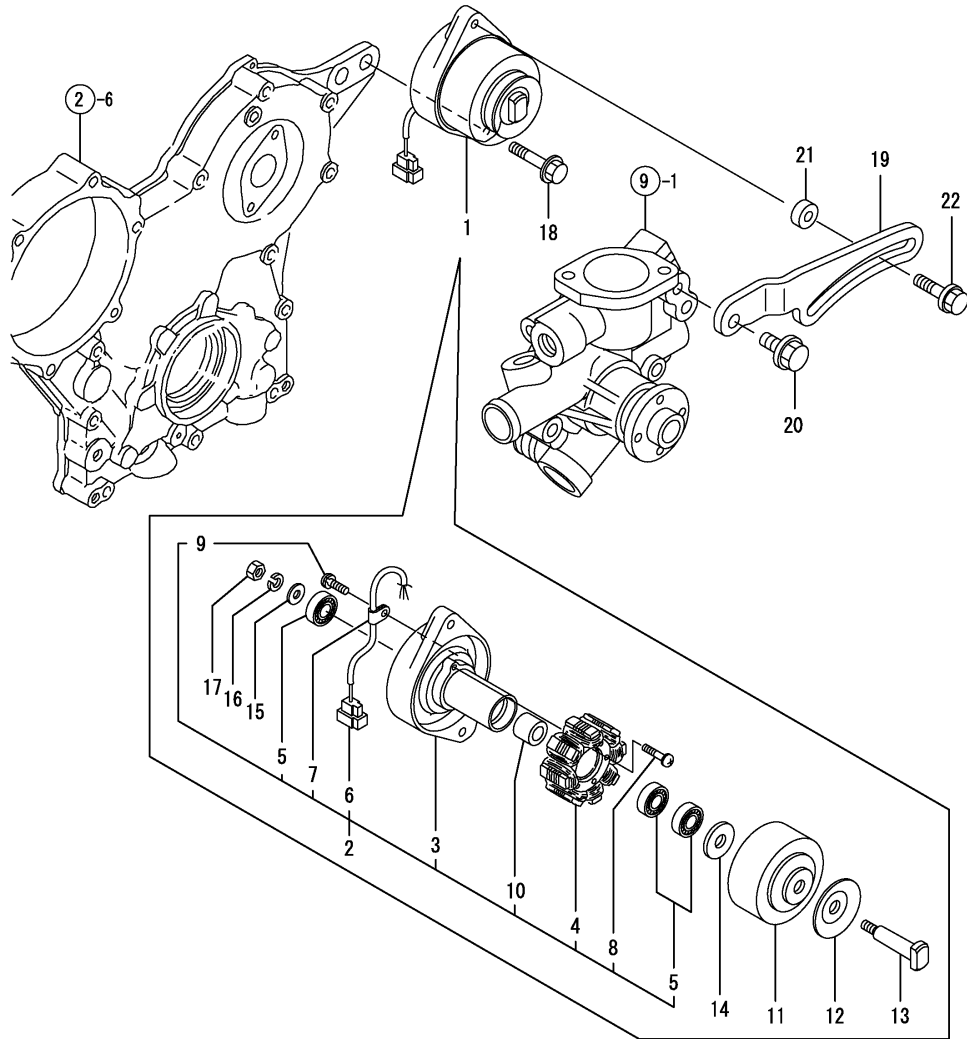

No.	Lev.	Parts No.	Description	Q'ty						I	R
				(A)	(B)	(C)	(D)	(E)	(F)		
1	1	171301-77201	DYNAMO ASSY, 15A	1							
2	2	XM08137	PLATE ASSY	1							
3	3	X2A07073KA	PLATE	1							
4	3	X4A07023KB	STATOR ASSY	1							
5	3	24104-062010	BEARING, 6201UUC3	3							
6	3	X417878	COUPLER	1							
7	3	XM069000000	CLAMP	1							
8	3	XYSPS402400	SCREW	2							
9	3	XYSPS400800	SCREW	1							
10	3	XM329830000	COLLAR	1							
11	2	X3A08877KA	FLYWHEEL	1							
12	2	XM721740000	PULLEY	1							
13	2	X4A07403K01	SHAFT	1							
14	2	XM67935	WASHER	1							
15	2	XM860250000	WASHER	1							
16	2	XM219230000	WASHER	1							
17	2	XM863720000	NUT	1							
18	1	26106-100402	BOLT, M10X 40 PLATED	1							
19	1	119742-77300	ADJUSTER	1							
20	1	26106-080202	BOLT, M8X 20 PLATED	1							
21	1	119940-77270	SPACER, GENERATOR	1							
22	1	129972-77341	BOLT, ADJUSTER L=50	1							

Fig.15. ELECTLIC PART

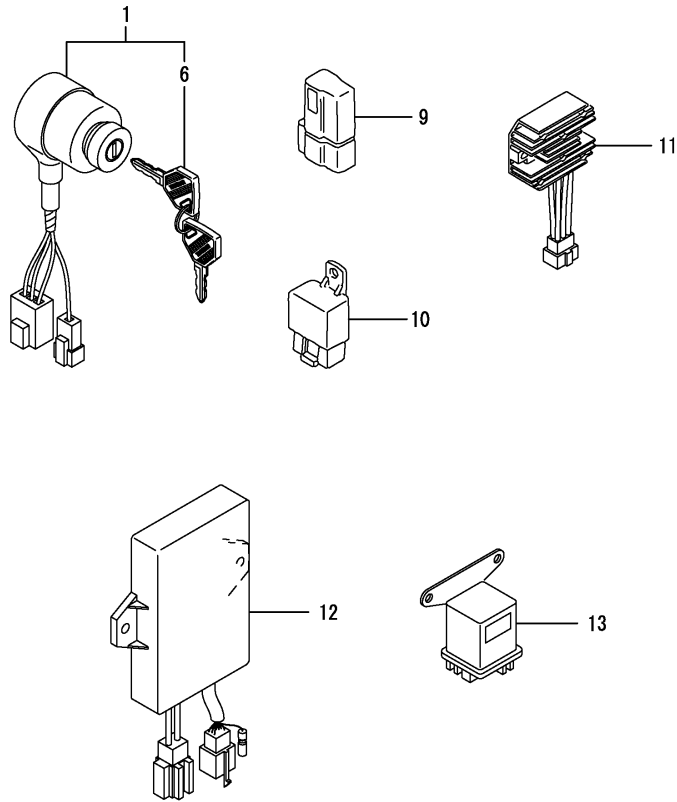

(A)=3TNV70-FDW
(B)=
(C)=

(D)=
(E)=
(F)=

No.	Lev.	Parts No.	Description	Q'ty						I	R
				(A)	(B)	(C)	(D)	(E)	(F)		
1	1	194940-52110	SWITCH, STARTING	1							
6	2	198360-52160	KEY ASSY	1							
9	1	119643-66900	DIODE	2							
10	1	119247-77100	RELAY, SAFETY	1							
11	1	119865-77700	LIMITER ASSY,CURRENT	1							
12	1	119546-77800	RELAY, EMERGENCY	1							
13	1	119650-77910	RELAY ASSY, GLOW	1							

Fig.16. GASKET SET

(A)=3TNV70-FDW
(B)=
(C)=

(D)=
(E)=
(F)=

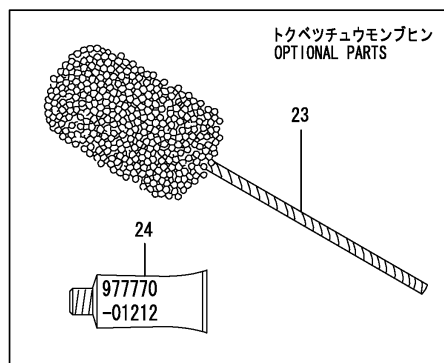
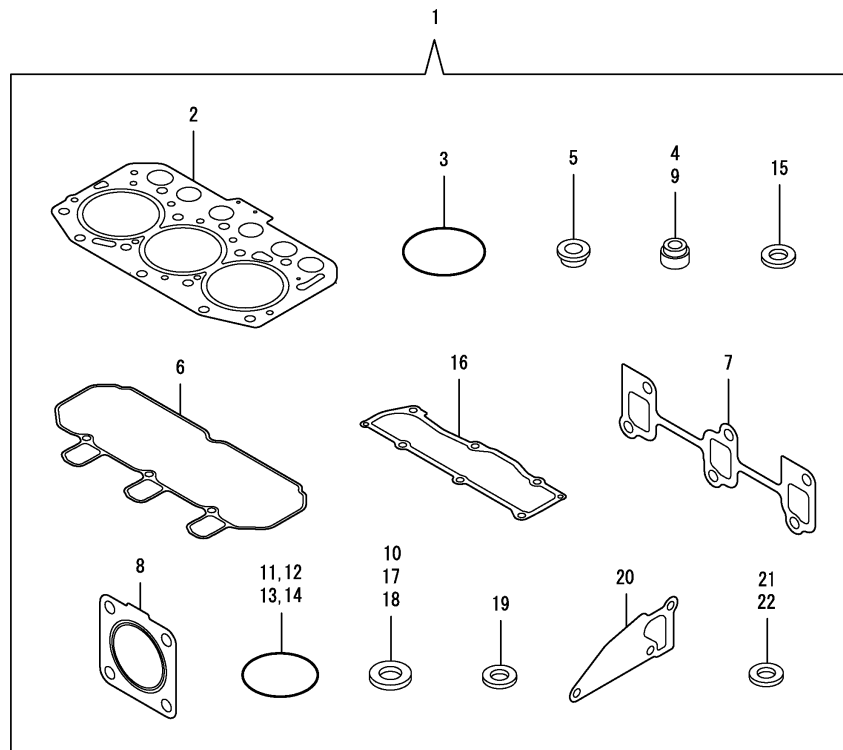

No.	Lev.	Parts No.	Description	Q'ty						I	R
				(A)	(B)	(C)	(D)	(E)	(F)		
1	1	719515-92630	GASKET SET	1							1
2	2	119515-01330	GASKET, HEAD	1							
3	2	121850-51960	O-RING	1							
4	2	119717-11340	SEAL, VALVE STEM	3							
5	2	129901-11450	PROTECTOR, NOZZLE	3							
6	2	119515-11310	GASKET, BONNET	1							
7	2	119717-13110	GASKET	1							
8	2	119515-13200	GASKET, SILENCER	1							
9	2	119717-11350	SEAL, VALVE STEM	3							
10	2	22190-080002	WASHER, SEAL 6	4							
11	2	24311-000320	O-RING, 1AP32.0	2							
12	2	119717-32060	O-RING, P15.0	1							
13	2	119624-32040	O-RING, P12.0	1							
14	2	119717-32050	O-RING, P17.0	3							
15	2	119600-11460	GASKET, NOZZLE	6							
16	2	119515-11330	GASKET	1							
17	2	22190-160002	WASHER, SEAL 16	1							
18	2	22190-120002	WASHER, SEAL 12	4							
19	2	129901-59560	GASKET	3							
20	2	119515-42020	GASKET, WATER PUMP	1							
21	2	23414-080000	GASKET, 8X1.0	1							
22	2	124465-44950	GASKET, 16	2							
23	1	129400-92410	HONE	1							1
24	1	977770-01212	GASKET, LIQUID	1							1

Remarks
(1) OPTIONAL PART.

Parts No. Index

Parts No.	Fig. No.	Ref. No.
101304-59020	12	32
	17	32
101720-55750	12	54
102103-55520	12	41
		49
	17	41
103854-39140	12	31
	17	31
104200-55321	12	45
104200-55330	12	36
		46
	17	36
104200-55341	12	47
104200-55750	12	38
		55
	17	38
105010-11490	4	5
105311-01090	1	6
105425-01690	3	7
110250-55610	12	40
		50
	17	40
114250-39450	8	10
118200-53010	12	2
	17	2
118400-51370	10	55
119131-18320	5	5
119233-77932	11	134
119247-77100	15	10
119285-01990	1	9
119285-11990	4	14
119305-35151	8	3
119415-44740	9	19
119415-51100	10	10
119515-01200	1	30
119515-01330	1	31
	16	2
119515-01720	3	4
119515-11100	4	16
119515-11110	4	17
119515-11200	4	24
119515-11240	4	25
119515-11280	4	29
119515-11310	4	49
	16	6
119515-11320	4	50
119515-11330	4	51
	16	16
119515-11380	4	38
119515-11750	4	6

Parts No.	Fig. No.	Ref. No.
119515-11800	4	12
119515-13200	5	7
	16	8
119515-14400	6	2
119515-14580	6	3
119515-21700	7	1
119515-22080	7	16
119515-22300	7	22
119515-22500	7	18
119515-22550	7	34
119515-22900	7	32
119515-23000	7	24
119515-23600	7	30
119515-23610	7	38
119515-42001	9	1
119515-42002	9	1 -1
119515-42020	9	12
	16	20
119515-42041	9	3
119515-42350	9	17
119515-53001	12	1
	17	1
119515-53010	12	3
	17	3
119515-59540	12	13
	17	13
119515-61440	11	21
119515-77010	13	2
119540-59570	12	20
	17	20
119546-01770	3	6
119546-21590	7	9
119546-35080	8	5
119546-59810	12	9
	17	9
119546-59820	12	10
	17	10
119546-59830	12	11
	17	11
119546-77800	15	12
119600-11460	4	4
	16	15
119620-01750	3	13
119620-01800	2	8
119620-02020	1	10
119620-14200	6	1
119620-21941	7	15
119620-59700	12	23
	17	23
119621-21680	7	14

Parts No.	Fig. No.	Ref. No.
119623-01250	1	7
119624-32040	2	20
	16	13
119643-66900	15	9
119650-77910	15	13
119660-01911	2	19
119660-61300	11	78
119660-61901	11	66
119717-01501	2	1
119717-01521	2	6
119717-01570	2	3
119717-01590	2	4
119717-01601	3	2
119717-01750	2	18
119717-02410	1	13
119717-02930	1	27
119717-03031	4	39
119717-03070	4	40
		41
119717-11131	4	18
119717-11190	4	20
119717-11260	4	28
119717-11340	4	21
	16	4
119717-11350	4	22
	16	9
119717-11650	4	30
119717-13110	5	2
	16	7
119717-13600	5	3
119717-21200	7	6
119717-21650	7	13
119717-23200	7	29
119717-23910	7	28
119717-25050	6	10
119717-25100	6	11
119717-25930	6	16
119717-32050	2	21
	16	14
119717-32060	8	4
	16	12
119717-32080	2	11
119717-32100	2	10
119717-32110	2	15
119717-32120	2	16
119717-39210	8	11
119717-42031	9	4
119717-42320	9	11
119717-49800	9	23
119717-51030	10	6

Parts No.	Fig. No.	Ref. No.
119717-51060	10	7
119717-51070	10	8
119717-51150	6	17
119717-51180	10	15
119717-51190	10	16
119717-51200	10	17
119717-51300	10	44
119717-51330	10	47
119717-51420	10	86
119717-51480	10	91
119717-51490	10	92
119717-51500	10	65
119717-51710	10	76
119717-51750	10	77
119717-51760	10	78
119717-61050	11	2
119717-61060	11	3
119717-61070	11	4
119717-61120	11	8
119717-61130	11	9
119717-61140	11	10
119717-61150	11	11
119717-61200	11	74
119717-61400	11	14
119717-61500	11	30
119717-77800	4	58
119717-77820	4	59
119718-13100	5	1
119742-61100	11	5
119742-77300	14	19
119761-61560	11	98
119802-03100	4	42
119802-03110	4	43
119802-03121	4	44
119802-03131	4	45
119802-03141	4	46
119802-13620	5	4
119802-32130	2	17
119802-34802	8	1
119810-02940	1	32
119810-55340	12	35
	17	35
119810-55650	12	42
	17	42
119813-59950	12	24
	17	24
119833-55620	12	34
	17	34
119833-55660	17	47
119840-59570	12	12

Parts No. Index

Parts No.	Fig. No.	Ref. No.
119840-59570	17	12
119865-21600	7	12
119865-77700	15	11
119940-77270	14	21
119C10-42320	9	11 -1
121111-21501	7	8
121120-01620	3	15
121250-44901	9	26
121250-55620	12	43
	17	43
121254-55510	12	39
	17	39
121256-44600	9	36
121257-55720	12	51
121257-55731	12	52
121450-42450	9	25
121470-44540	9	34
121520-34810	8	16
121550-49111	9	16
121850-51960	2	22
	16	3
122710-51090	10	9
124060-01050	1	5
124064-55510	12	48
124066-59100	12	21
	17	21
124085-02220	3	3
124160-01751	2	30
	4	37
124160-01910	1	8
124450-44510	9	29
124450-44530	9	31
124450-44550	9	35
124450-44560	9	32
124465-44950	9	27
		28
	16	22
124550-51350	10	48
129001-32320	2	13
129001-32330	2	14
129005-59830	8	12
129052-61390	11	13
129053-55640	17	45
129053-55650	17	46
129100-01580	3	1
	7	2
129100-35140	8	2
129100-51560	10	70
129100-51570	10	71
129100-52101	10	96

Parts No.	Fig. No.	Ref. No.
129100-61650	11	60
129150-11230	4	31
129150-11750	4	33
129150-25301	6	15
129150-59120	12	4
	17	4
129150-59131	12	7
	17	7
129155-51020	10	5
129155-51140	10	13
129155-51280	10	42
		43
	11	6
129155-51400	10	57
129155-51450	10	60
129155-51521	10	66
129155-51530	10	67
129155-51540	10	68
129155-51550	10	69
129155-51580	10	73
129155-51591	10	74
129155-51600	10	22
129155-51701	10	75
129155-52051	10	95
129155-61341	11	79
129155-61450	11	22
129155-61460	11	80
129155-61480	11	24
129156-51910	10	80
129156-61460	11	23
129209-61370	11	12
129209-61930	11	132
129209-61970	11	133
129242-55750	17	50
129242-55760	17	51
129335-55700	12	44
129335-55740	17	48
129335-55750	17	44
129335-55770	17	49
129335-55780	17	53
129350-49530	9	22
129400-92410	16	23
129457-44760	9	20
129486-61540	11	50
129508-11180	4	19
129573-61700	11	131
129612-42340	9	18
129900-07900	4	1
129900-32130	2	12
129901-11450	4	3

Parts No.	Fig. No.	Ref. No.
129901-11450	16	5
129901-59560	12	19
	16	19
	17	19
129972-77341	14	22
158552-61700	11	61
158552-61710	11	65
158552-61900	11	83 -1
158600-51170	10	14
158600-51270	10	41
158600-51410	10	58
158600-51420	10	59
158600-51441	10	49
158600-51570	10	72
158600-51790	10	79
158601-61700	11	90
171081-55910	12	56
171301-77201	14	1
174307-51700	11	31
194940-52110	15	1
198360-52160	15	6
22190-080002	8	13
		15
	16	10
22190-100002	11	72
22190-120002	11	81
	12	30
		33
		59
	16	18
	17	30
		33
		55
22190-160002	3	9
	10	81
	16	17
22217-060000	10	82
22217-120000	6	18
22242-000120	4	34
22252-000220	7	23
22272-000030	11	67
22351-050010	10	83
22351-060012	4	23
22372-040000	11	82
22512-040120	7	5
22857-500100	4	52
		53
22857-500160	4	54
23061-070230	9	33
23414-080000	9	13

Parts No.	Fig. No.	Ref. No.
23414-080000	16	21
23414-120016	11	135
23418-060000	12	57
23857-030000	8	14
23876-005000	4	15
23876-030000	2	9
23887-100002	11	73
24101-060034	10	84
24101-063034	10	85
24104-062010	14	5
24311-000110	17	52
24311-000320	2	31
	4	55
	16	11
24311-000440	17	54
24311-240100	12	37
		58
	17	37
24316-000150	10	56
24341-000070	11	68
24341-000280	11	83
26022-050122	10	87
26022-060162	10	88
26106-050102	10	89
26106-060102	8	9
	11	69
		84
26106-060122	2	23
	3	10
	6	9
26106-060142	11	85
26106-060162	2	24
26106-060202	4	56
	11	86
26106-060252	3	11
26106-060352	6	14
26106-060402	2	25
		26
26106-060452	3	12
	9	21
	11	87
26106-060602	2	27
26106-060652	2	28
26106-060752	4	57
26106-080122	9	14
26106-080162	4	2
26106-080202	9	24
	14	20
26106-080402	4	36
26106-080502	9	15

Parts No. Index

Parts No.	Fig. No.	Ref. No.
26106-100252	13	1
26106-100402	14	18
26206-100252	3	14
26306-080002	2	29
	5	6
26366-080002	11	70
26577-060122	9	9
26716-060002	10	90
26716-120002	6	19
26736-120002	11	88
26756-060002	11	71
		89
26979-050162	4	35
27241-120000	1	14
27241-250000	9	10
719515-01560	1	1
719515-92630	16	1
719546-51380	10	1
719717-01500	2	5
719717-02900	1	15
719717-02910	1	35
977770-01212	2	32
	3	16
	4	60
	16	24
X0280210331	13	24
X0280335360	13	34
X0280626010	13	13
X0280996180	13	4
X0281007680	13	3
X0282005871	13	7
X0283006960	13	8
X0284105040	13	14
X0284525010	13	28
X0285007030	13	11
X0285105190	13	5
X0285205030	13	6
X0286105010	13	16
X0286305010	13	18
X0286355010	13	19
X0287405140	13	20
X0534007800	13	21
X1289510130	13	35
X2A07073KA	14	3
X3A08877KA	14	11
X417878	14	6
X4284001590	13	9
X4A07023KB	14	4
X4A07403K01	14	13
X9055715000	13	22

Parts No.	Fig. No.	Ref. No.
X9490065670	13	33
X9490138090	13	26
X9490138100	13	27
X9490138110	13	25
X9490423520	13	31
X9490560750	13	30
X9490562360	13	29
X9490721360	13	23
X9491034320	13	17
X9491034330	13	15
X9491040990	13	12
X9491050100	13	10
XM069000000	14	7
XM08137	14	2
XM219230000	14	16
XM329830000	14	10
XM67935	14	14
XM721740000	14	12
XM860250000	14	15
XM863720000	14	17
XYS400800	14	9
XYS402400	14	8

Parts No.	Fig. No.	Ref. No.
-----------	----------	----------

Parts No.	Fig. No.	Ref. No.
-----------	----------	----------