

OCD10-M74401EN

PREFACE

1. This parts catalog is the 2nd edition of 3TNE84-EIKC for IHI Construction Machinery Limited.

Pub.No. : 000Y00D7441

Published : October.,2006

2. Model name

Engine model	Vehicle		Vehicle made by
	Products	Model name	
3TNE84-EIKC	Crawler Crane	CCH30T	IHI Construction Machinery Ltd.

Directions for the Parts Catalog.

1. This Parts Catalog shows both standard and optional parts.
2. Parts may change without prior notice.
3. The following is an example of the Parts Catalog format.

REF.	LEV.	PARTS NO.	DESCRIPTION	Q'TY						I	R
				(A)	(B)	(C)	(D)	(E)	(F)		
1	1	729595-51390	FUEL INJECTION PUMP	1	1	1	1	1			1
1-1	1	729595-51391	FUEL INJECTION PUMP	1	1	1	1	1		N	1
		(A=E00185) (B=E00200)									
3	2	26022-060162	SCREW M 6X 16	9	9	9	9	9			
3-1	2	26022-060162	SCREW M 6X 16	4	4	4	4	4		K	
		(A=E00156) (B=E00156) (C=E00156) (D=E00156) (E=E00156)									
4	2	129470-51040	CAMSHAFT	1	1	1	1	1			
5	2	122710-51050	BEARING, ROLLER	2	2	2	2	2			
6	2	129470-51060	RETAINER	1	1	1	1	1			

Remarks
(1) BOOST COMPEMSATOR TYPE. OPTIONAL PART, TO E00155,(4JH-DT, 4JH-DTZ

① Ref. No.

The Ref. No. listed may not be in accordance with the illustration Ref. No.

(Ex.) Illustration No.

List Ref No.

1

1

(Before change)

1-1

(After change)

For interchangeable symbols N, R and K, illustrations for new parts may be abbreviated.

② Lev. (Level)

Level indication

The numbers below indicate the level of relativity towards the main part.

1 ----- Main parts (Assembly parts)

2 ----- Sub component included in " 1 ".

3 ----- Sub component included in " 2 ".

Note) Parts that are not for sale are partially illustrated but not listed.

③ Interchangeability Symbol

When a part change takes place, one of the following interchangeability symbols is indicated beside the part.

Symbol	Interchangeability	Contents note
N	Old $\begin{matrix} \leftarrow \text{Yes} \\ \text{No} \rightarrow \end{matrix}$ New	New Part is interchangeable for Old Part but Old Part is not interchangeable for New Part.
Q	Old $\begin{matrix} \leftarrow \text{No} \\ \text{Yes} \rightarrow \end{matrix}$ New	New Part is not interchangeable for Old Part but Old Part is interchangeable for New Part.
R	Old $\begin{matrix} \leftarrow \text{Yes} \\ \text{Yes} \rightarrow \end{matrix}$ New	New/ Old Parts are both interchangeable.
S	Old $\begin{matrix} \leftarrow \text{No} \\ \text{No} \rightarrow \end{matrix}$ New	New/ Old Parts are both not interchangeable.
W		Part newly added.
Z		Part discontinued.
F		Not interchangeable by a single part but interchangeable together with related parts.
K		Changes only for used parts quantities.

④ Effective Machine No.

When a part changes, the effective Machine No. will be indicated in the (A)-(F) column.

Product Symbol	Product No.	Product Symbol	Product No.
C	Clutch No. Compressor No.	F	Machine No. (Agricultural Equip.)
D	Drive No.	M	Machine No.
E	Engine No.		

Note 1) A date may follow the symbol. (Ex.) 1996.01

Note 2) "XXXXX" and "ZZZZZ" are for parts that could not be predicted or for engine models that could not be identified.

Note 3) (A=E00185) is the E (Engine Serial Number) for the column (A) model (in this case 4JH-DT) after the parts design change.

⑤ Remarks

Figures or alphabets (symbols) are entered in the remarks column.

The comments (remarks) on parts that are indicated at the bottom of the illustration are the same symbols as those stated above.

Contents

Fig. No. Fig. Name

Fig. No. Fig. Name

ENGINE SECTION

1. CYLINDER BLOCK
2. GEAR HOUSING
3. FLYWHEEL HOUSING & OIL SUMP
4. CYLINDER HEAD & BONNET
5. SUCTION MANIFOLD & AIR CLEANER
6. EXHAUST MANIFOLD & SILENCER
7. CAMSHAFT & DRIVING GEAR
8. CRANKSHAFT & PISTON
9. LUB.OIL SYSTEM
10. COOLING WATER SYSTEM
11. FUEL INJECTION PUMP
12. GOVERNOR
13. FUEL INJECTION VALVE
14. FUEL LINE
15. STARTING MOTOR
16. GENERATOR
17. GASKET SET

Fig.1. CYLINDER BLOCK

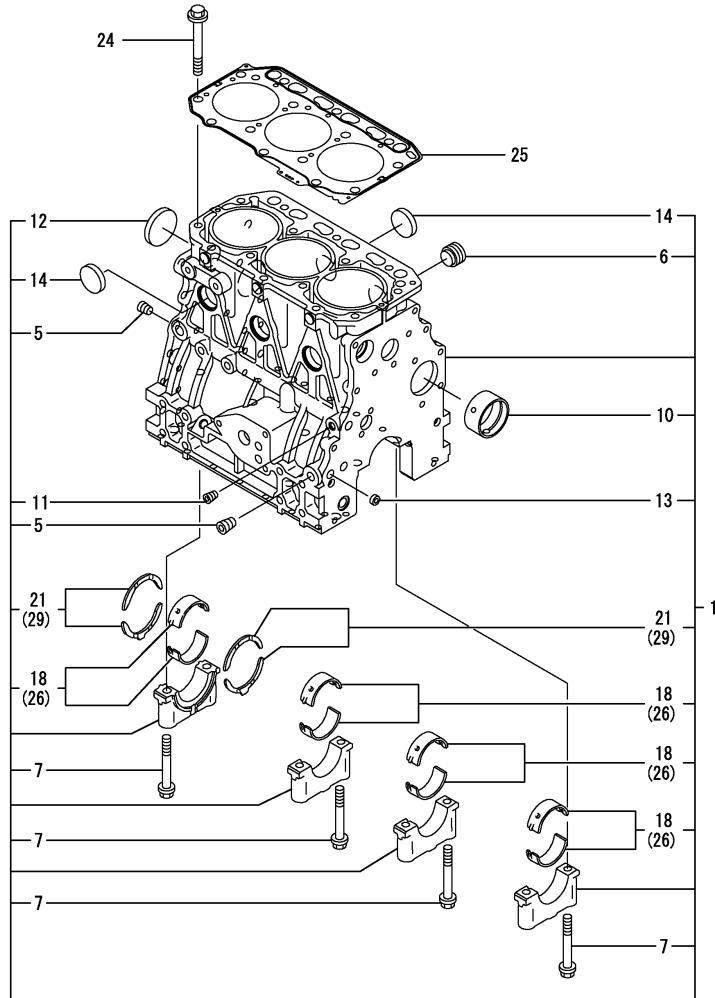

(A)=3TNE84-EIKC
(B)=
(C)=

(D)=
(E)=
(F)=

No.	Lev.	Parts No.	Description	Q'ty						I	R
				(A)	(B)	(C)	(D)	(E)	(F)		
1	1	729002-01560	BLOCK ASSY, CYLINDER	1							
5	2	124160-01910	PLUG, PT1/4	3							
6	2	171051-01921	PLUG, NPTF1	1							
7	2	129150-02020	BOLT, METAL CAP	8							
10	2	129795-02411	BUSH, CAMSHAFT	1							
10-1	2	129795-02412	BUSH, CAMSHAFT	1							N
(A=E70781)											
11	2	23876-010000	PLUG, R01	1							
12	2	129001-01250	PLUG, 50	1							
13	2	27241-120000	PLUG, 12	2							
14	2	27241-300000	PLUG 30	6							
18	2	129001-02930	BEARING, MAIN	4							3
18-1	2	129001-02931	BEARING, MAIN	4							N 3
(A=E70781)											
21	2	129150-02930	BEARING, THRUST	2							
21-1	2	129150-02931	BEARING, THRUST	2							N
(A=E70781)											
24	1	129150-01200	BOLT, HEAD	14							
25	1	129002-01331	GASKET, HEAD	1							
26	1	129150-02870	BEARING, 0.25 US	4							1
26-1	1	129150-02871	BEARING, 0.25 US	4							N 1
(A=E70781)											
29	1	129150-02940	BEARING, THRUST 0.25	1							2
29-1	1	129150-02941	BEARING, THRUST 0.25	1							N 2
(A=E70781)											

Remarks

- (1) UNDER-SIZE(U.S=0.25)PART.
- (2) OVER-SIZE(O.S=0.25)PART.
- (3) REPAIR PART.

Fig.2. GEAR HOUSING

(A)=3TNE84-EIKC

(B)=

(C)=

(D)=

(E)=

(F)=

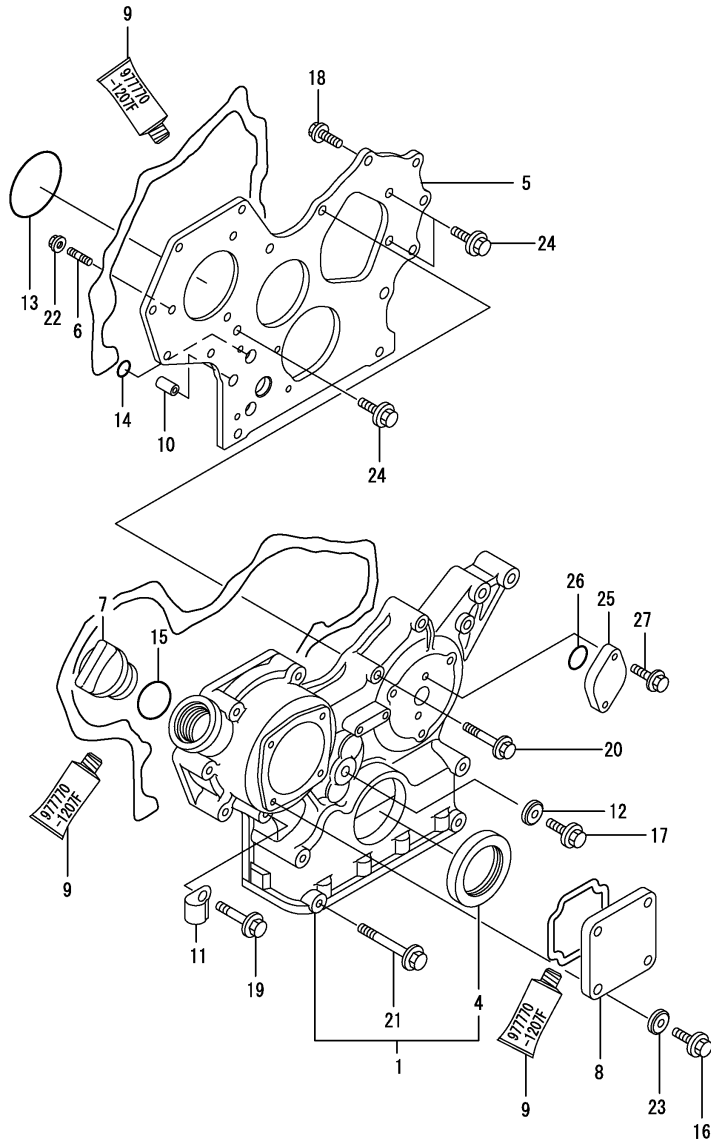

No.	Lev.	Parts No.	Description	Q'ty						I	R
				(A)	(B)	(C)	(D)	(E)	(F)		
1	1	719810-01500	CASE ASSY, GEAR	1							
4	2	129795-01800	SEAL, OIL	1							
5	1	129400-01520	FLANGE, GEAR CASE	1							
6	1	121450-01560	STUD, M8X22	3							
7	1	124160-01751	COVER, FILLER	1							
8	1	124240-01871	COVER	1							
9	1	977770-1207F	GASKET.LIQUID	1							1
10	1	129795-01950	PIPE, KNOCK L=18	2							
11	1	129150-03100	RETAINER, PIPE	1							
12	1	22190-080002	WASHER, SEAL 6	1							
13	1	121850-51960	O-RING	1							
14	1	24311-000160	O-RING, 1AP16.0	2							
14-1	1	119609-32040	O-RING, P16	2							R
(A=E70780)											
15	1	24311-000320	O-RING, 1AP32.0	1							
16	1	26106-080122	BOLT, M8X 12 PLATED	4							
17	1	26106-080162	BOLT, M8X 16 PLATED	1							
18	1	26106-080202	BOLT, M8X 20 PLATED	2							
19	1	26106-080452	BOLT, M8X 45 PLATED	6							
20	1	26106-080552	BOLT, M8X 55 PLATED	3							
21	1	129001-91841	BOLT, M8X85	4							
22	1	26366-080002	NUT, M8	3							
22-1	1	26306-080002	NUT, M8	3							N
(A=E70780)											
23	1	22190-080002	WASHER, SEAL 6	4							
24	1	26106-080162	BOLT, M8X 16 PLATED	3							
25	1	121023-01550	COVER	1							
25-1	1	121023-01551	COVER	1							R
(A=E70781)											
26	1	24341-000240	O-RING, 1AS24.0	1							
27	1	26106-060162	BOLT, M6X 16 PLATED	2							

Remarks
(1) OPTIONAL PART.

Fig.3. FLYWHEEL HOUSING & OIL SUMP

(A)=3TNE84-EIKC

(B)=

(C)=

(D)=

(E)=

(F)=

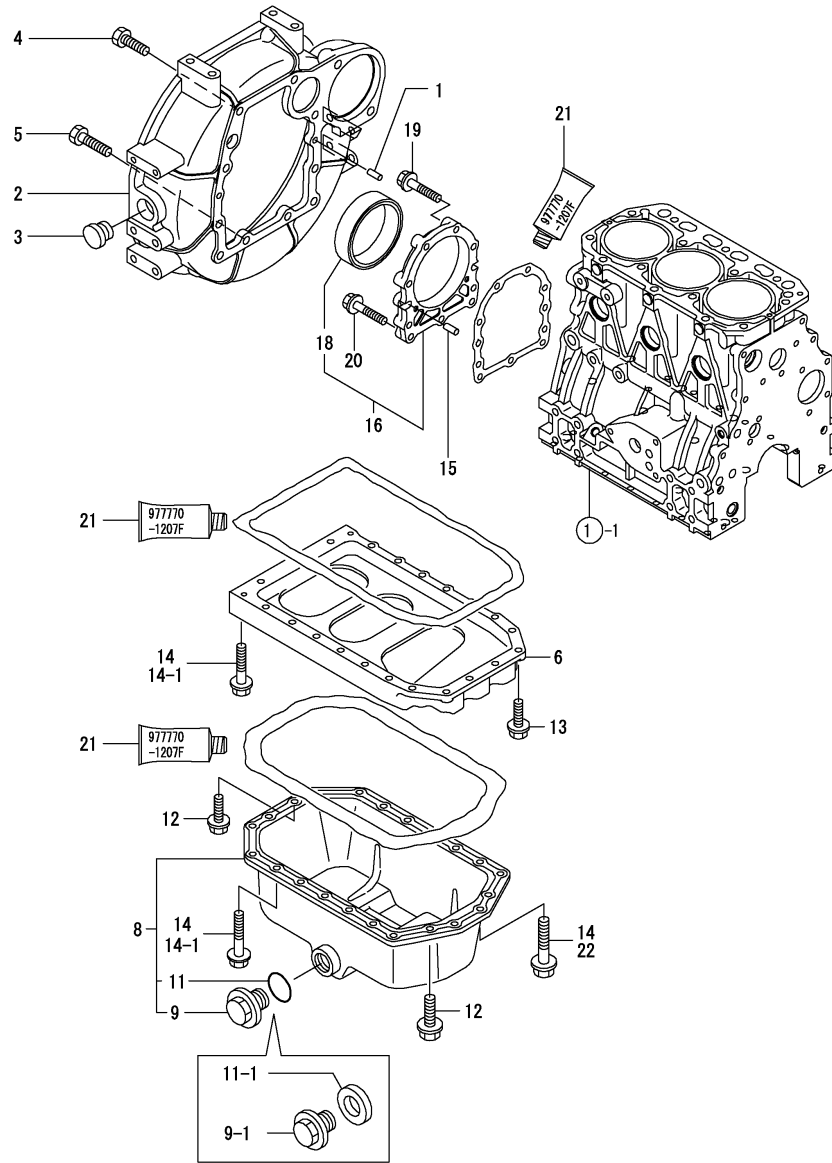

No.	Lev.	Parts No.	Description	Q'ty						I	R
				(A)	(B)	(C)	(D)	(E)	(F)		
1	1	129100-01580	PIN, M8X16	2							
2	1	129612-01600	HOUSING, FLYWHEEL	1							
3	1	119620-01750	CAP	1							
4	1	26206-100252	BOLT, M10X 25 PLATED	6							
5	1	26206-100302	BOLT, M10X 30 PLATED	4							
6	1	129100-01730	SPACER, OIL SUMP	1							
8	1	129100-01760	SUMP ASSY, OIL	1							
9	2	171301-01640	PLUG, 22	1							
9-1	2	119640-01640	PLUG, DRAIN M22	1							S
(A=E70781)											
11	2	24341-000250	O-RING, 1AS25.0	1							
11-1	2	22190-220002	WASHER, SEAL 22	1							S
(A=E70781)											
12	1	26106-080162	BOLT, M8X 16 PLATED	4							
13	1	26106-080252	BOLT, M8X 25 PLATED	2							
14	1	26106-080452	BOLT, M8X 45 PLATED	20							
14-1	1	26106-080452	BOLT, M8X 45 PLATED	16							K
(A=FROM 1ST)											
15	1	129100-01580	PIN, M8X16	2							
16	1	129100-01640	CASE ASSY, OIL SEAL	1							
18	2	129795-01780	SEAL, OIL	1							
19	1	129486-01670	BOLT, M8X30	6							
20	1	26106-080352	BOLT, M8X 35 PLATED	3							
21	1	977770-1207F	GASKET,LIQUID	1							1
22	1	26106-080502	BOLT, M8X 50 PLATED	4							W
(A=FROM 1ST)											

Remarks
(1) OPTIONAL PART.

Fig.4. CYLINDER HEAD & BONNET

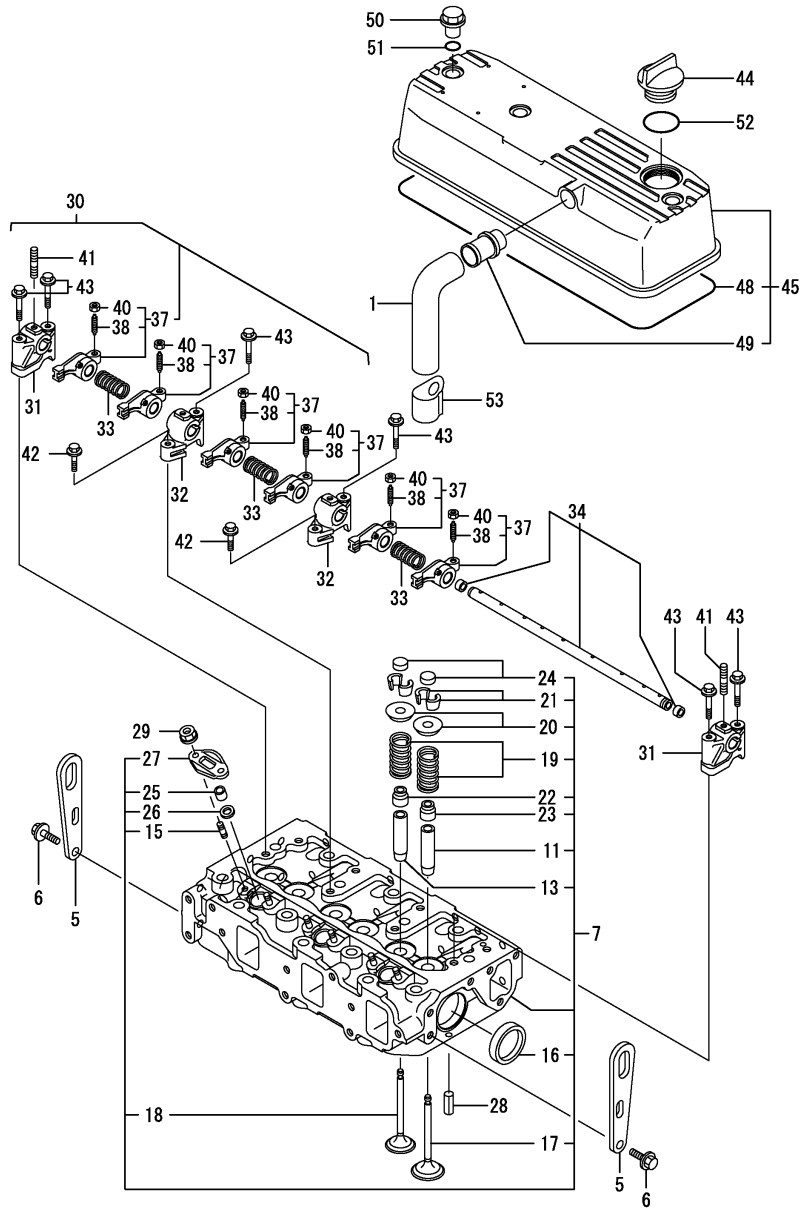

(A)=3TNE84-EIKC

(B)=

(C)=

(D)=

(E)=

(F)=

No.	Lev.	Parts No.	Description	Q'ty						I	R
				(A)	(B)	(C)	(D)	(E)	(F)		
1	1	129410-03090	PIPE , BREATHER	1							
5	1	124736-07900	LIFTER	2							
6	1	26106-080142	BOLT, M8X 14 PLATED	4							
7	1	129001-11700	HEAD ASSY, CYLINDER	1							
11	2	120130-11860	GUIDE, VALVE	3							1
13	2	129150-11810	GUIDE, VALVE	3							1
15	2	26216-060202	STUD, M6X 20	6							
16	2	27241-400000	PLUG, 40	2							
17	2	129100-11100	VALVE, INTAKE	3							
18	2	129100-11110	VALVE, EXHAUST	3							
18-1	2	129100-11112	VALVE, EXHAUST	3							R
(A=E70781)											
19	2	129795-11120	SPRING, VALVE	6							
20	2	129795-11180	RETAINER, SPRING	6							
21	2	27310-080001	COTTER, 8	6							
22	2	121400-11340	SEAL, VALVE STEM	3							
23	2	124460-11340	SEAL, VALVE STEM	3							
24	2	129150-11370	CAP, VALVE	6							
25	2	119625-11870	PROTECTOR, NOZZLE	3							
26	2	119625-11880	SEAT, NOZZLE	3							
27	2	119625-11900	RETAINER, NOZZLE	3							
28	1	22351-060012	PIN, SPRING 6.0X12	2							
29	1	26366-060002	NUT, M6	6							
30	1	129155-11241	SHAFT ASSY, ROCKER	1							
31	2	129155-11260	SUPPORT, ROCKER ARM	2							
32	2	129155-11270	SUPPORT, ROCKER ARM	2							
33	2	129150-11280	SPRING	3							
34	2	129150-11290	SHAFT, ROCKER ARM	1							
37	2	729402-11650	ARM ASSY, ROCKER	6							
38	3	129150-11230	SCREW, VALVE ADJUST	6							
40	3	129150-11750	NUT, M8	6							
41	2	26226-080182	STUD, M8X 18	3							
41-1	2	119802-11280	STUD	3							R
(A=E70780)											
42	1	26106-080252	BOLT, M8X 25 PLATED	2							
43	1	26106-080502	BOLT, M8X 50 PLATED	6							
44	1	124160-01751	COVER, FILLER	1							
45	1	129001-11351	BONNET ASSY, HEAD	1							
48	2	129001-11310	GASKET, BONNET	1							
49	2	129001-11340	PIPE , BREATHER	1							
50	1	124160-11360	KNOB	3							
51	1	24311-000120	O-RING, 1AP12.0	3							
52	1	24311-000320	O-RING, 1AP32.0	1							
53	1	129150-03100	RETAINER, PIPE	1							

Remarks

(1) REPAIR PART.

N:Old $\xrightarrow{\text{Yes}}$ New, Q:Old $\xrightarrow{\text{No}}$ New, R:Old $\xrightarrow{\text{Yes}}$ New, S:Old $\xrightarrow{\text{No}}$ New, W:Add, Z:Discontinued, F:Interchangeable by set, K:Q'ty Change

Fig.5. SUCTION MANIFOLD & AIR CLEANER

(A)=3TNE84-EIKC

(B)=

(C)=

(D)=

(E)=

(F)=

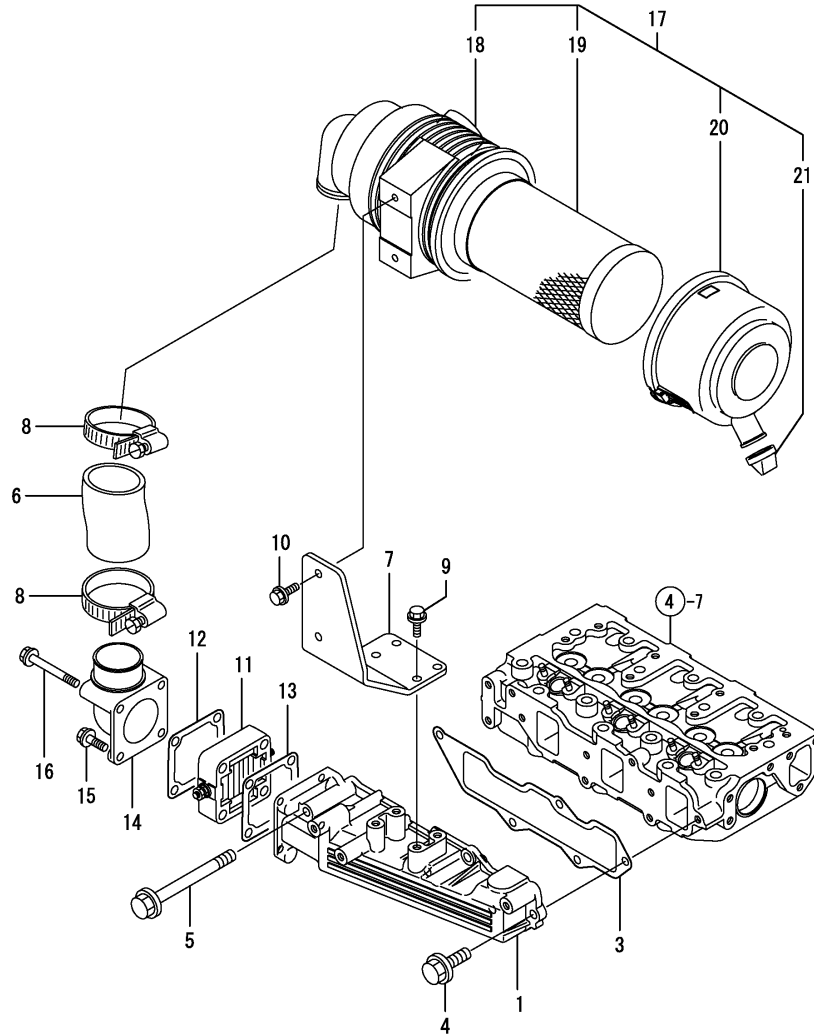

No.	Lev.	Parts No.	Description	Q'ty						I	R
				(A)	(B)	(C)	(D)	(E)	(F)		
1	1	129001-12100	MANIFOLD, AIR INTAKE	1							
3	1	129001-12110	GASKET, MANIFOLD	1							
4	1	26106-080202	BOLT, M8X 20 PLATED	4							
5	1	26106-080802	BOLT, M8X 80 PLATED	1							
6	1	119910-12210	PIPE, AIR INTAKE	1							
7	1	119910-12560	BRACKET, AIR CLEANER	1							
8	1	23000-060000	CLAMP, 60	2							
9	1	26013-080222	BOLT, M8X 22	4							
10	1	26013-080222	BOLT, M8X 22	2							
11	1	129100-77500	HEATER, AIR 12V	1							
11-1	1	129100-77501	HEATER	1							N
(A=E70781)											
12	1	129100-77510	GASKET, AIR HEATER	1							
13	1	129150-77511	GASKET	1							
14	1	171340-77520	BEND	1							
15	1	26106-080402	BOLT, M8X 40 PLATED	2							
16	1	26106-080802	BOLT, M8X 80 PLATED	2							
17	1	129211-12540	CLEANER ASSY, AIR	1							
18	2	129211-12590	BODY	1							
19	2	119808-12520	ELEMENT	1							
20	2	119866-12540	COVER ASSY	1							
21	2	119808-12540	VALVE, UNLOADER	1							

Fig.6. EXHAUST MANIFOLD & SILENCER

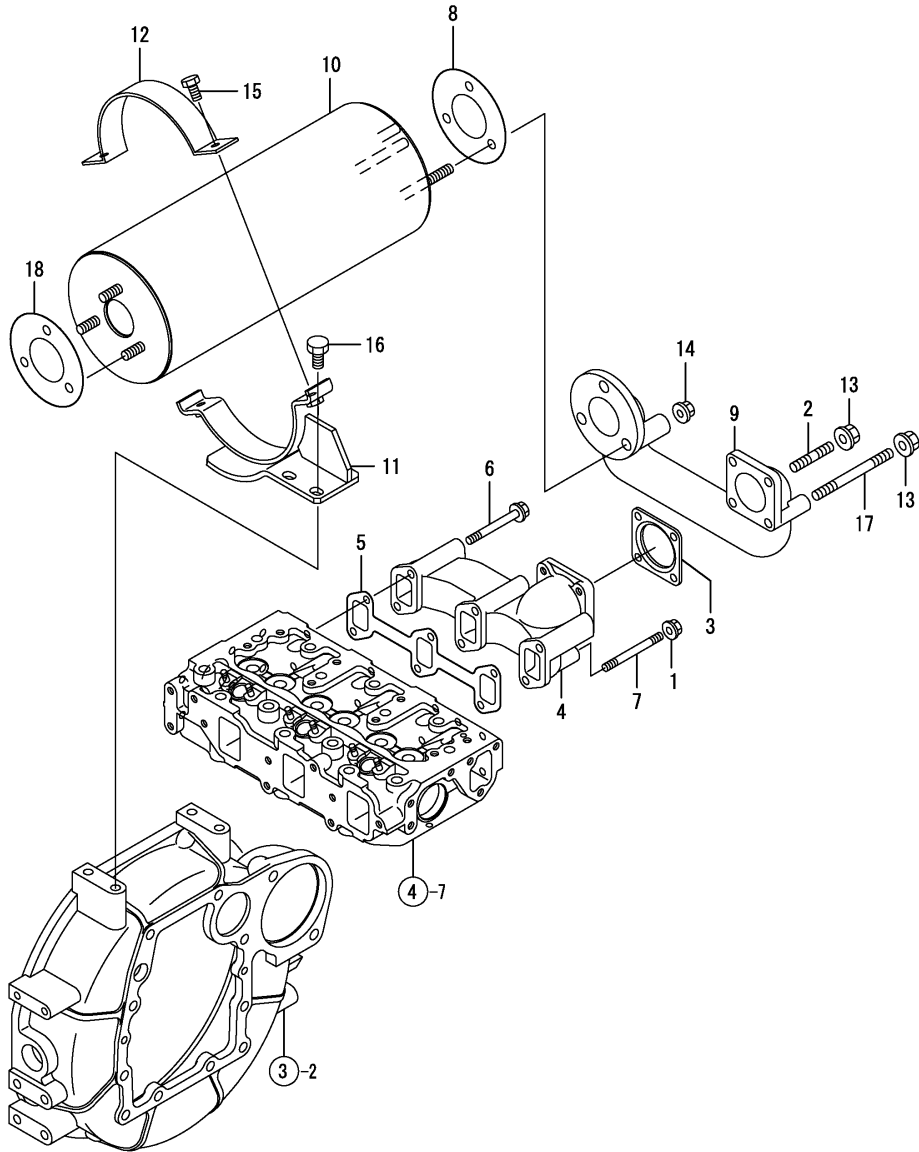

(A)=3TNE84-EIKC

(B)=

(C)=

(D)=

(E)=

(F)=

No.	Lev.	Parts No.	Description	Q'ty						I	R
				(A)	(B)	(C)	(D)	(E)	(F)		
1	1	26366-080002	NUT, M8	2							
1-1	1	26306-080002	NUT, M8	2							N
(A=E70780)											
2	1	119131-18320	STUD, M8X22	2							
3	1	124701-11911	GASKET, SILENCER	1							
4	1	129100-13110	MANIFOLD, EXHAUST	1							
5	1	129150-13110	GASKET	1							
6	1	26106-080802	BOLT, M8X 80 PLATED	4							
6-1	1	123900-13630	BOLT, M8X80	4							N
(A=E70781)											
7	1	26216-080802	STUD, M8X 80	2							
7-1	1	123900-13610	STUD, M8X80	2							N
(A=E70781)											
8	1	103954-13201	GASKET, SILENCER	1							
9	1	129130-13560	PIPE	1							
10	1	129136-13520	SILENCER	1							
11	1	129211-13600	STAY, SILENCER	2							
12	1	129211-13610	BAND, SILENCER	2							
13	1	26366-080002	NUT, M8	4							
13-1	1	26306-080002	NUT, M8	4							N
(A=E70780)											
14	1	194990-22060	NUT W/WASHER 10	3							
14-1	1	26306-100002	NUT, M10	3							N
(A=E70780)											
15	1	26106-080352	BOLT, M8X 35 PLATED	4							
16	1	26106-100162	BOLT, M10X 16 PLATED	4							
17	1	26216-080652	STUD, M8X 65	2							
17-1	1	119802-13750	STUD, M8X65	2							N
(A=E70781)											
18	1	103954-13201	GASKET, SILENCER	1							

Fig.7. CAMSHAFT & DRIVING GEAR

(A)=3TNE84-EIKC

(B)=

(C)=

(D)=

(E)=

(F)=

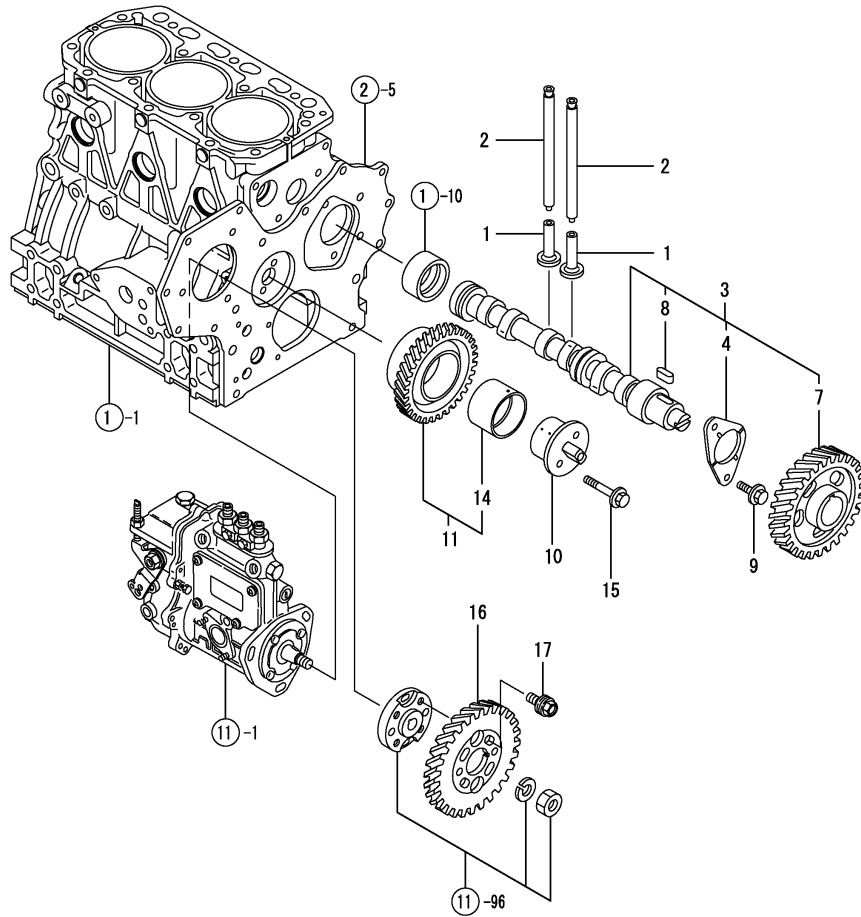

No.	Lev.	Parts No.	Description	Q'ty						I	R
				(A)	(B)	(C)	(D)	(E)	(F)		
1	1	129150-14200	TAPPET	6							
2	1	129150-14400	ROD, PUSH L=178	6							
3	1	129129-14580	CAMSHAFT ASSY	1							
4	2	129150-02450	BEARING, THRUST	1							
7	2	129150-14101	GEAR, CAMSHAFT	1							
8	2	22512-070140	KEY, 7X 14	1							
9	1	26106-080142	BOLT, M8X 14 PLATED	2							
10	1	129100-25061	SHAFT, IDLE	1							
11	1	129150-25101	GEAR ASSY, IDLE	1							
14	2	129150-25920	BUSH, IDLE GEAR	1							1
15	1	26106-080452	BOLT, M8X 45 PLATED	2							
16	1	129150-25931	GEAR, PUMP	1							
17	1	129150-25301	BOLT	4							

Remarks

(1) REPAIR PART.

Fig.8. CRANKSHAFT & PISTON

(A)=3TNE84-EIKC

(B)=

(C)=

(D)=

(E)=

(F)=

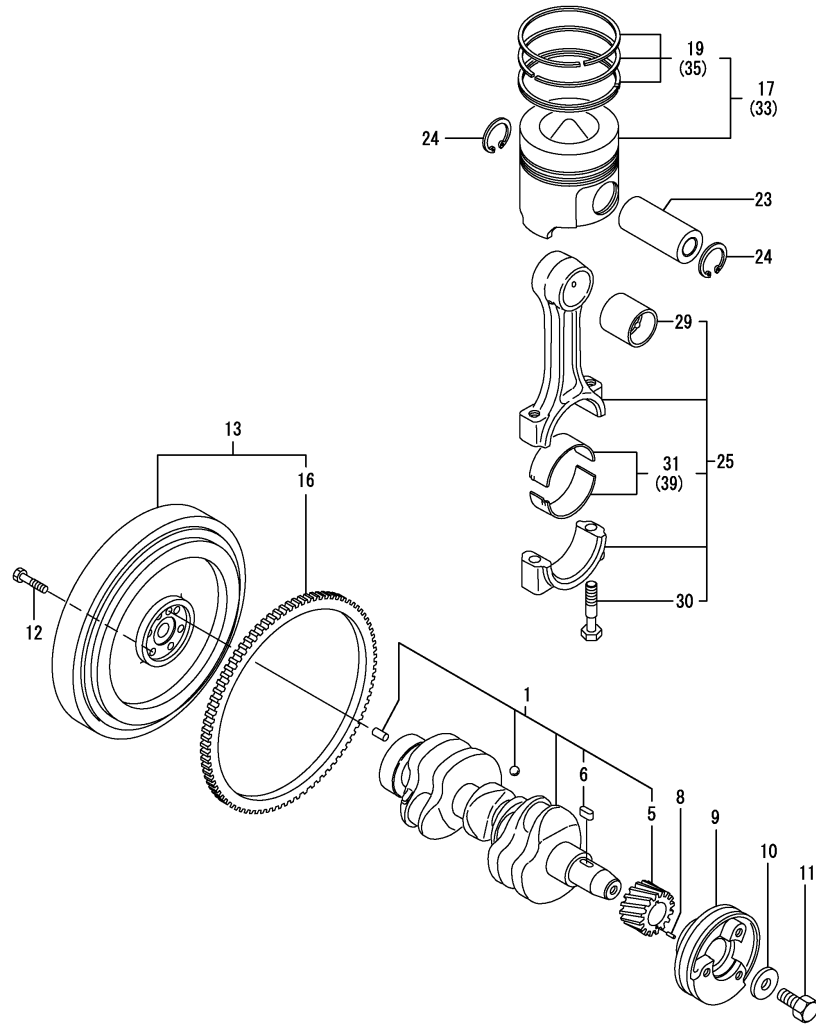

No.	Lev.	Parts No.	Description	Q'ty						I	R
				(A)	(B)	(C)	(D)	(E)	(F)		
1	1	129001-21100	CRANKSHAFT ASSY	1							
5	2	129150-21200	GEAR, CRANKSHAFT	1							
6	2	22512-070140	KEY, 7X 14	1							
8	1	22351-040010	PIN, SPRING 4.0X10	1							
9	1	171340-21650	V-PULLEY	1							
10	1	129795-21661	WASHER	1							
11	1	121850-21680	BOLT	1							
12	1	121111-21501	BOLT, FLYWHEEL	6							
13	1	129211-21590	FLYWHEEL ASSY	1							
16	2	119865-21600	GEAR, RING	1							
17	1	129002-22081	PISTON ASSY	3							
19	2	129002-22500	RING SET, PISTON	3							
23	1	129202-22300	PIN, PISTON D26 L70	3							
24	1	22252-000260	RING, 26	6							
25	1	729402-23100	ROD ASSY, CONNECTING	3							
29	2	129100-23910	BEARING, PISTON PIN	3							1
30	2	121550-23200	BOLT, CONNECTING ROD	6							
31	2	129150-23600	BEARING, CRANK PIN	3							
31-1	2	129150-23601	BEARING, CRANK PIN	3							N
		(A=E70781)									
33	1	129002-22901	PISTON ASSY, 0.25 OS	3							2
35	2	129002-22950	RING SET, 0.25 OS	3							2
39	1	129150-23610	BEARING, 0.25 US	3							3
39-1	1	129150-23611	BEARING, 0.25 US	3							N 3
		(A=E70781)									

Remarks

- (1) REPAIR PART.
- (2) OVER-SIZE(O.S=0.25)PART.
- (3) UNDER-SIZE(U.S=0.25)PART.

Fig.9. LUB.OIL SYSTEM

(A)=3TNE84-EIKC
(B)=
(C)=

(D)=
(E)=
(F)=

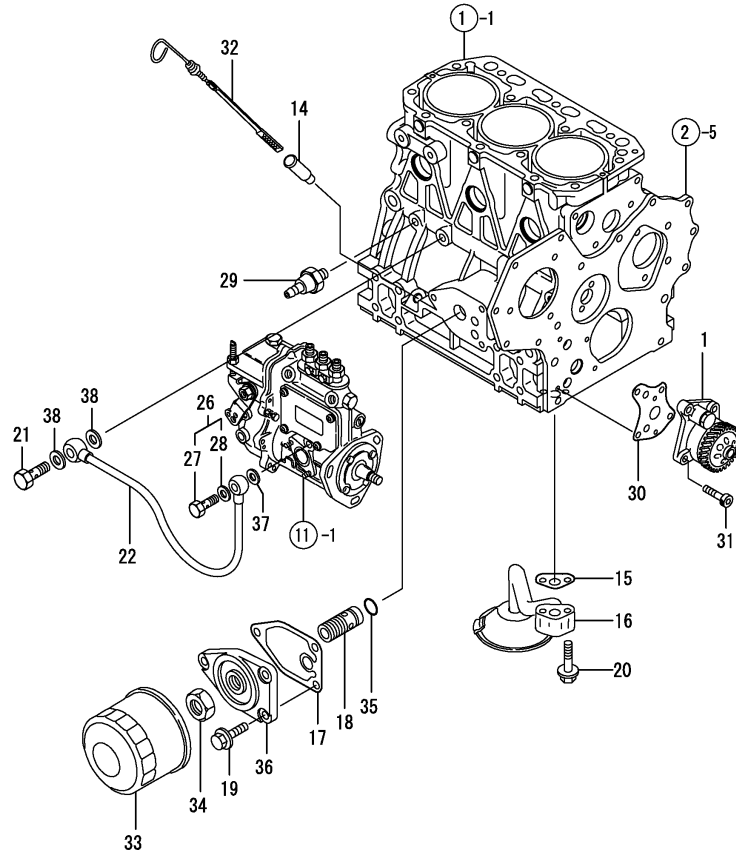

No.	Lev.	Parts No.	Description	Q'ty						I	R
				(A)	(B)	(C)	(D)	(E)	(F)		
1	1	129001-32001	PUMP ASSY, OIL	1							
14	1	121520-34810	GUIDE, DIPSTICK	1							
15	1	129150-35041	GASKET	1							
15-1	1	129150-35042 (A=E70781)	GASKET	1							N
16	1	129100-35301	PIPE ASSY, OIL INLET	1							
17	1	129150-35111	GASKET	1							
18	1	129001-35300	BOLT, FILTER	1							
19	1	26106-080202	BOLT, M8X 20 PLATED	3							
20	1	26106-080352	BOLT, M8X 35 PLATED	2							
21	1	124160-39140	BOLT, PIPE JOINT M10	1							
22	1	129150-39450	PIPE ASSY, OIL	1							
26	1	124550-59830	BOLT ASSY, JOINT M8	1							
27	2	124550-59820	BOLT, PIPE JOINT M8	1							
28	2	22190-080002	WASHER, SEAL 6	1							
29	1	121252-39450	SWITCH, 0.5KG	1							
30	1	129150-32020	GASKET, PUMP	1							
31	1	26450-060252	BOLT, M6X 25	4							
32	1	171420-34820	DIPSTICK, OIL	1							
33	1	129150-35153	FILTER 80X80L	1							1
34	1	129150-35350	NUT	1							
35	1	24311-000160	O-RING, 1AP16.0	1							
36	1	129150-35101	BRACKET, STRAINER	1							
37	1	22190-080002	WASHER, SEAL 6	1							
38	1	22190-100002	WASHER, SEAL 10	2							

Remarks
(1) REPAIR PART.

Fig.10. COOLING WATER SYSTEM

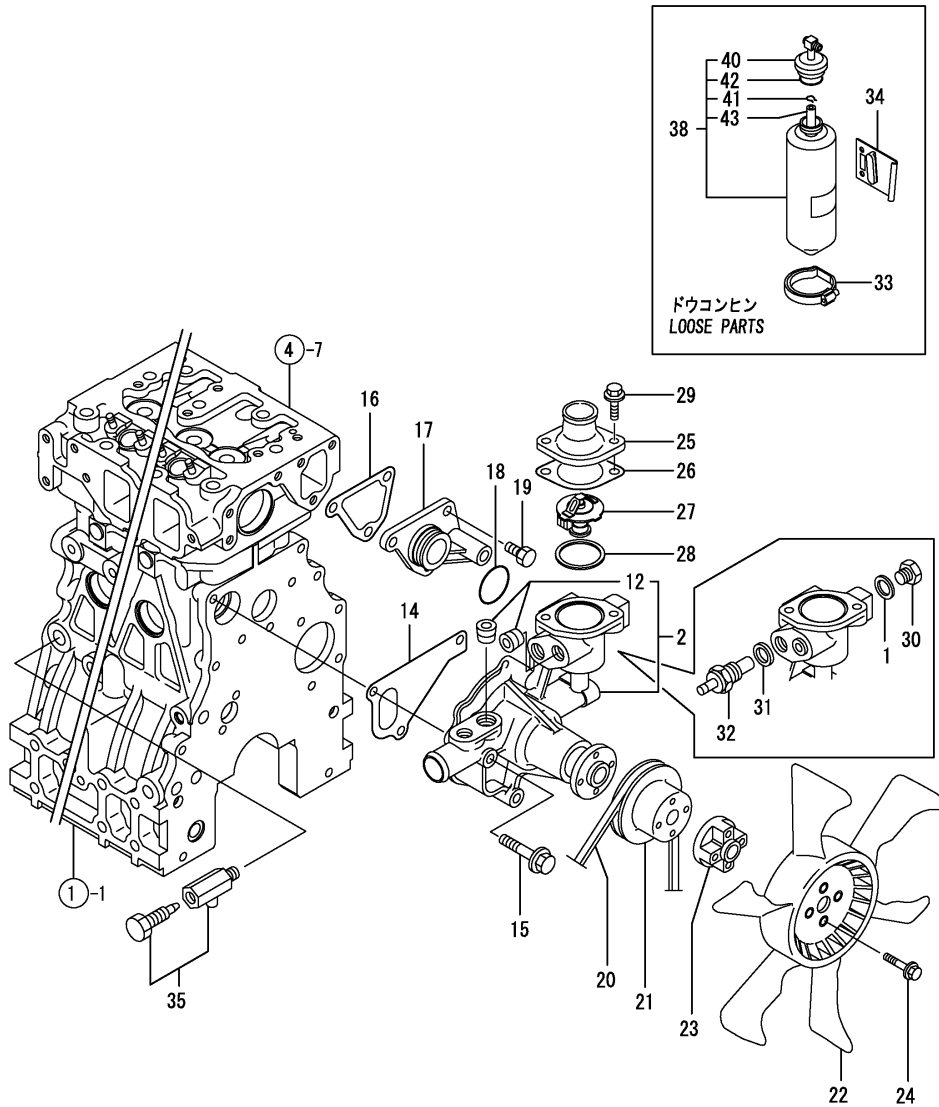

(A)=3TNE84-EIKC

(B)=

(C)=

(D)=

(E)=

(F)=

No.	Lev.	Parts No.	Description	Qty						I	R
				(A)	(B)	(C)	(D)	(E)	(F)		
1	1	129150-49360	GASKET	1							
2	1	129001-42003	PUMP ASSY, WATER	1							
2-1	1	129001-42004	PUMP ASSY, WATER	1							N
(A=E70781)											
12	2	23876-030000	PLUG, R03	2							
12-1	2	129916-49740	PLUG, R03	2							N
(A=E70781)											
14	1	129486-42021	GASKET, WATER PUMP	1							
15	1	26106-080602	BOLT, M8X 60 PLATED	3							
16	1	124395-49840	GASKET	1							
17	1	129001-42040	JOINT	1							
18	1	129486-42140	O-RING, G30	1							
19	1	26106-080162	BOLT, M8X 16 PLATED	3							
20	1	119831-42290	V-BELT, A37.5	1							
21	1	129155-42350	V-PULLEY	1							
22	1	171340-44740	FAN, COOLING D335XNF	1							
23	1	121267-44760	SPACER	1							
24	1	26014-060302	BOLT, M6X 30	4							
25	1	129350-49560	COVER, THERMOSTAT	1							
26	1	129795-49551	GASKET	1							
27	1	129155-49800	THERMOSTAT, 71	1							
27-1	1	129155-49801	THERMOSTAT, 71	1							N
(A=E70781)											
28	1	129150-49811	GASKET, THERMOSTAT	1							
29	1	26106-080202	BOLT, M8X 20 PLATED	2							
30	1	121450-42450	PLUG, M16	1							
31	1	124465-44950	GASKET, 16	1							
32	1	171056-49351	SENSOR	1							
33	1	124450-44550	BAND	1							
34	1	121256-44600	BRACKET, SUB TANK	1							
35	1	119620-49290	COCK ASSY, 1/4	1							
38	1	171064-44510	TANK ASSY, SUB	1							
40	2	121450-44531	CAP	1							
41	2	124450-44560	RETAINER	1							
42	2	121470-44581	GASKET	1							
43	2	23065-070225	HOSE 7X 225	1							

Fig.11. FUEL INJECTION PUMP

(A)=3TNE84-EIKC

(B)=

(C)=

(D)=

(E)=

(F)=

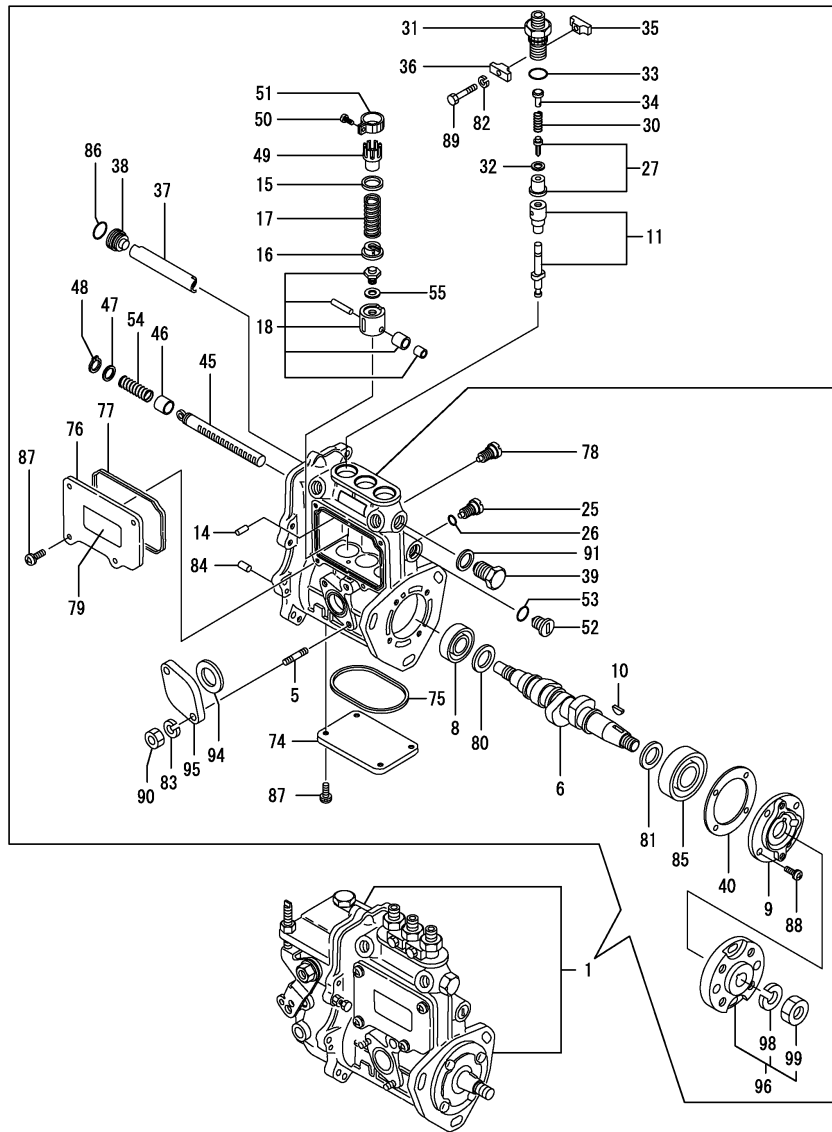

No.	Lev.	Parts No.	Description	Q'ty						I	R
				(A)	(B)	(C)	(D)	(E)	(F)		
1	1	729231-51450	PUMP ASSY, INJECTION	1							1
5	2	129155-51020	STUD	2							
6	2	119810-51040	CAMSHAFT	1							
8	2	129155-51050	BEARING, 17BM001D	1							
8-1	2	129155-51051	BEARING	1							R
(A=E70781)											
9	2	129208-51060	SUPPORT	1							
10	2	122710-51090	KEY	1							
11	2	129506-51100	PLUNGER ASSY	3							
14	2	129155-51140	PIN	3							
15	2	174307-51170	RETAINER, SPRING A	3							
16	2	129155-51180	RETAINER, SPRING	3							
17	2	124950-51190	SPRING, PLUNGER	3							
18	2	129155-51200	TAPPET ASSY	3							
25	2	129155-51270	STOPPER, TAPPET	3							
26	2	129155-51280	O-RING, S6	3							
27	2	129450-51300	VALVE ASSY, DELIVERY	3							
30	2	129155-51320	SPRING, DELIVERY	3							
31	2	129155-51340	RETAINER	3							
32	2	124550-51350	GASKET, DELIVERY	3							
33	2	124550-51370	O-RING	3							
33-1	2	24316-000150	O-RING, 4DP15.0	3							N
(A=E70781)											
34	2	129155-51370	STOPPER, VALVE	3							
35	2	129155-51380	STOPPER	2							
36	2	129155-51390	STOPPER	2							
37	2	129155-51400	DEFLECTOR	1							
38	2	129155-51410	BOLT	1							
39	2	129155-51420	PLUG, M16	1							
40	2	129155-51450	SHIM SET, ADJUSTING	1							
45	2	129155-51500	RACK, CONTROL	1							
45-1	2	119717-51500	RACK, CONTROL	1							R
(A=E70781)											
46	2	129155-51521	BUSH, RACK	1							
47	2	129155-51530	SPACER	1							
48	2	129155-51540	CIRCLIP	1							
49	2	129155-51550	PINION, CONTROL	3							
50	2	122117-51560	SCREW	3							
50-1	2	129100-51570	SCREW	3							N
(A=E70780)											
51	2	174307-51560	PINION	3							
51-1	2	129100-51560	PINION	3							N
(A=E70780)											
52	2	129155-51570	PLUG, M12	1							
53	2	129155-51580	O-RING	1							
54	2	129155-51591	SPRING, RACK	1							
55	2	129155-51600	SHIM SET, ADJUSTING	3							
74	2	129155-51701	COVER	1							
75	2	129155-51711	GASKET	1							
76	2	129155-51751	COVER	1							
77	2	129155-51760	GASKET	1							

Remarks

(1) GOVERNOR ASSY(FIG.12) IS INCORPORATED IN THIS FOP.CMP (REF.NO.1).

Fig.11. FUEL INJECTION PUMP

(A)=3TNE84-EIKC

(B)=

(C)=

(D)=

(E)=

(F)=

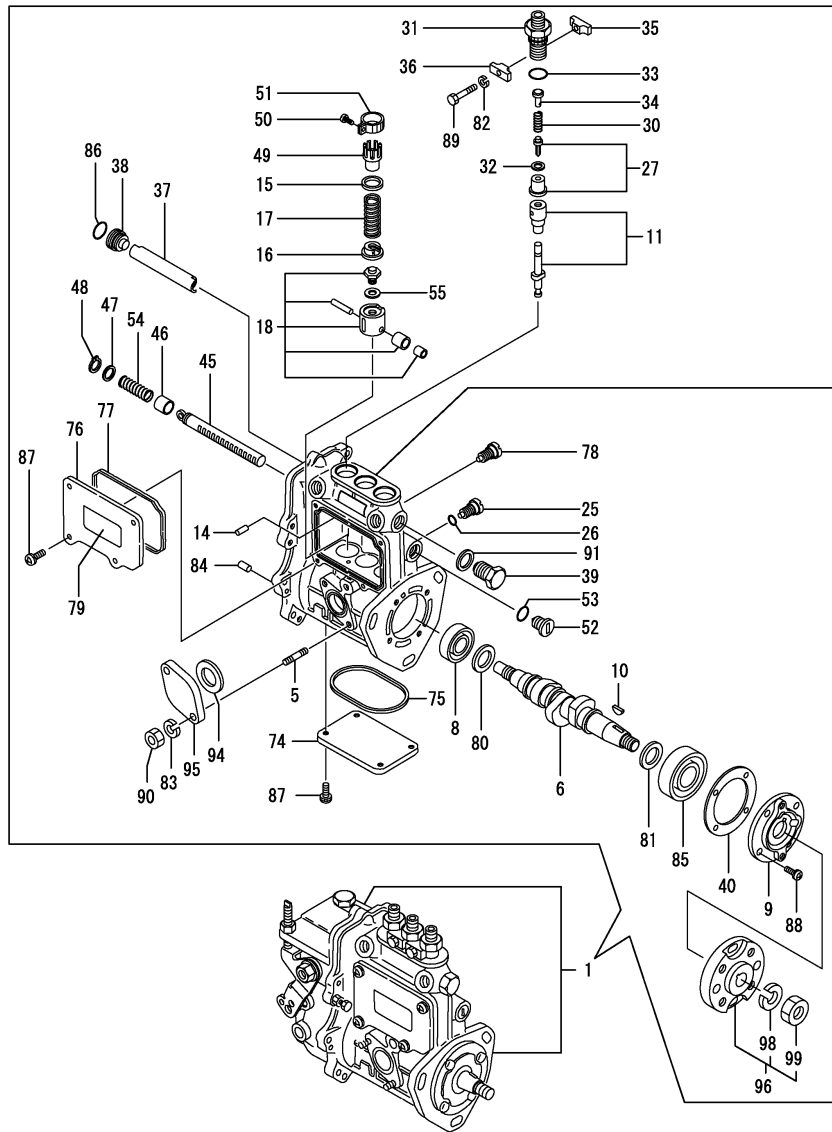

No.	Lev.	Parts No.	Description	Q'ty						I	R
				(A)	(B)	(C)	(D)	(E)	(F)		
77-1	2	129155-51761	GASKET	1							N
		(A=EXXXXX)									
78	2	129155-51790	STOOPER, RACK	1							
79	2	129156-51910	LABEL, CAUTION	1							
80	2	129155-51930	SPACER, T=3.25	1							
81	2	129155-51940	SPACER, T=1.5	1							
82	2	22217-050000	WASHER, SPRING 5	2							
83	2	22217-060000	WASHER, SPRING 6	2							
84	2	22351-050010	PIN, SPRING 5.0X10	2							
85	2	24101-063034	BEARING, BALL 6303	1							
86	2	24341-000160	O-RING, 1AS16.0	1							
86-1	2	119717-51420	O-RING	1							N
		(A=E70781)									
87	2	26022-050122	SCREW, M5X12	8							
88	2	26022-060162	SCREW, M6X16	4							
89	2	26116-050302	BOLT, M5X 30 PLATED	2							
90	2	26716-060002	NUT, M6	2							
91	2	22190-160002	WASHER, SEAL 16	1							
94	2	129155-52050	GASKET	1							
94-1	2	129155-52051	GASKET	1							N
		(A=EXXXXX)									
95	2	129100-52200	COVER	1							
96	2	129208-54500	FLANGE ASSY	1							
98	3	22217-120000	WASHER, SPRING 12	1							
99	3	26716-120002	NUT, M12	1							

Remarks

(1) GOVERNOR ASSY(FIG.12) IS INCORPORATED IN THIS FOP.CMP (REF.NO.1).

Fig.12. GOVERNOR

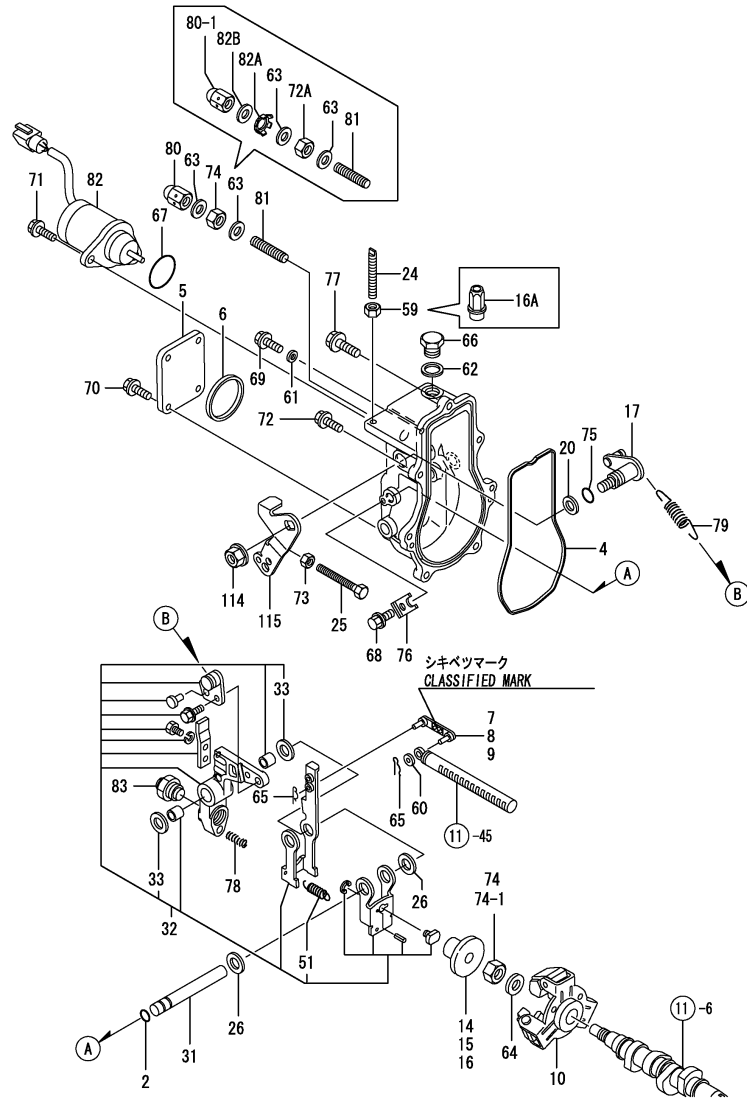

No.	Lev.	Parts No.	Description	Q'ty						I	R
				(A)	(B)	(C)	(D)	(E)	(F)		
2	2	129155-51280	O-RING, S6	1							
4	2	129052-61050	GASKET	1							
4-1	2	129052-61051	GASKET	1							N
(A=EXXXXX)											
5	2	129052-61060	COVER, GOVERNOR CASE	1							
6	2	129052-61070	GASKET	1							
6-1	2	129052-61071	GASKET	1							N
(A=EXXXXX)											
7	2	129155-61120	LINK, L=30 MARK 0	1							1
8	2	129155-61130	LINK, L=31 MARK 1	1							1
9	2	129155-61140	LINK, L=30.5 MARK 05	1							1
10	2	129486-61201	WEIGHT ASSY,GOVERNOR	1							
14	2	129155-61341	SLEEVE	1							2
15	2	129155-61350	SLEEVE, L=24.9	1							2
16	2	129155-61360	SLEEVE, L=25.2	1							2
16A	2	129209-61370	NUT, M6	1							W
(A=E70780)											
17	2	129100-61400	SHAFT ASSY	1							
20	2	129155-61430	SPACER	1							
24	2	129155-61450	BOLT, LIMITER	1							
25	2	129155-61460	BOLT, IDLE	1							
26	2	129155-61480	SPACER ASSY	2							
31	2	129052-61390	SHAFT	1							
32	2	119908-61501	LEVER ASSY, GOVERNOR	1							
33	3	174307-51700	SHIM SET	2							
51	3	129486-61540	SPRING, SET	1							
59	2	124550-66370	NUT, M6	1							Z
(A=E70780)											
60	2	22117-040000	WASHER, 4	1							
61	2	22190-060003	SEAL WASER 6	1							
62	2	22190-100002	WASHER, SEAL 10	1							
63	2	22190-120002	WASHER, SEAL 12	2							
64	2	22287-120000	WASHER, 12	1							
65	2	22372-040000	PIN, SNAP 4	2							
66	2	23887-100002	PLUG, 10	1							
67	2	24341-000280	O-RING, 1AS28.0	1							
67-1	2	158552-61900	O-RING	1							N
(A=EXXXXX)											
68	2	26106-060102	BOLT, M6X 10 PLATED	1							
69	2	26106-060102	BOLT, M6X 10 PLATED	1							
70	2	26106-060102	BOLT, M6X 10 PLATED	4							
71	2	26106-060142	BOLT, M6X 14 PLATED	2							
72	2	26106-060202	BOLT, M6X 20 PLATED	6							
72A	2	26736-120002	NUT, M12	1							W
(A=E70780)											
73	2	26756-060002	NUT, LOCK M6	1							
74	2	26776-120002	NUT, LOCK M12	2							
74-1	2	26776-120002	NUT, LOCK M12	1							K
(A=E70780)											
75	2	129155-61830	O-RING, S10	1							
76	2	119660-61901	RETAINER, SHAFT	1							

Remarks
 (1) SELECTIVE PARTS;CERTAIN THE CLASSIFICATION MARK, THEN PLACE YOUR ORDER. (REF.TO.ILLUSTRATION).
 (2) SELECTIVE PART.
 * THIS FIGURE(GOVERNOR ASSY)IS INCORPORATED IN THE FUEL INJECTION PUMP ASSY(FIG.11).

Fig.12. GOVERNOR

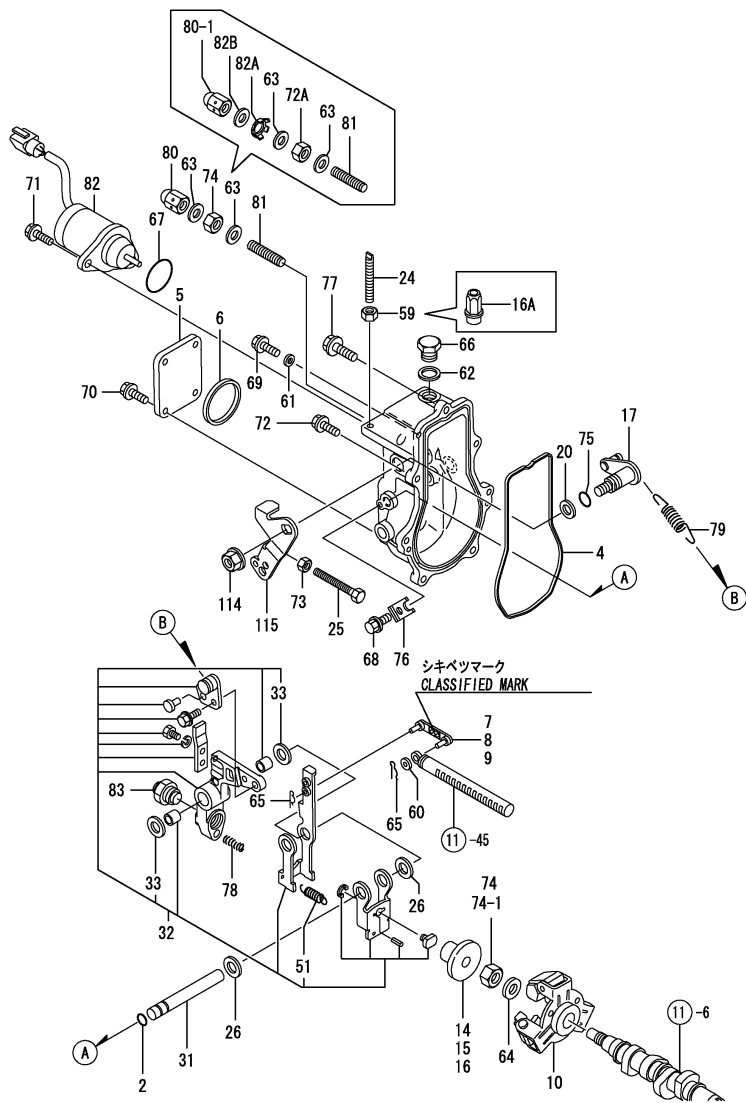

(A)=3TNE84-EIKC

(B)=

(C)=

(D)=

(E)=

(F)=

No.	Lev.	Parts No.	Description	Q'ty						I	R
				(A)	(B)	(C)	(D)	(E)	(F)		
77	2	129155-61950	BOLT	1							
78	2	129100-61650	SPRING, CONTROLLER	1							
79	2	171353-61710	SPRING, GOVERNOR	1							
80	2	26687-120002	NUT, CAP M12	1							
80-1	2	129209-61930	NUT, CAP	1							S
(A=E70780)											
81	2	120323-61470	BOLT, CONTROL	1							
82	2	119233-77931	SOLENOID, STOP	1							
82-1	2	119233-77932	SOLENOID, STOP	1							N
(A=E70780)											
82A	2	129209-61970	PLATE	1							W
(A=E70781)											
82B	2	23414-120016	GASKET, 12X1.0	1							W
(A=E70781)											
83	2	171353-61550	ANGLEICH ASSY	1							
114	2	26366-080002	NUT, M8	1							
115	2	129100-61440	LEVER, CONTROL	1							

Remarks

(1) SELECTIVE PARTS; CERTAIN THE CLASSIFICATION MARK, THEN PLACE YOUR ORDER. (REF. TO ILLUSTRATION).

(2) SELECTIVE PART.

* THIS FIGURE (GOVERNOR ASSY) IS INCORPORATED IN THE FUEL INJECTION PUMP ASSY (FIG. 11).

Fig.13. FUEL INJECTION VALVE

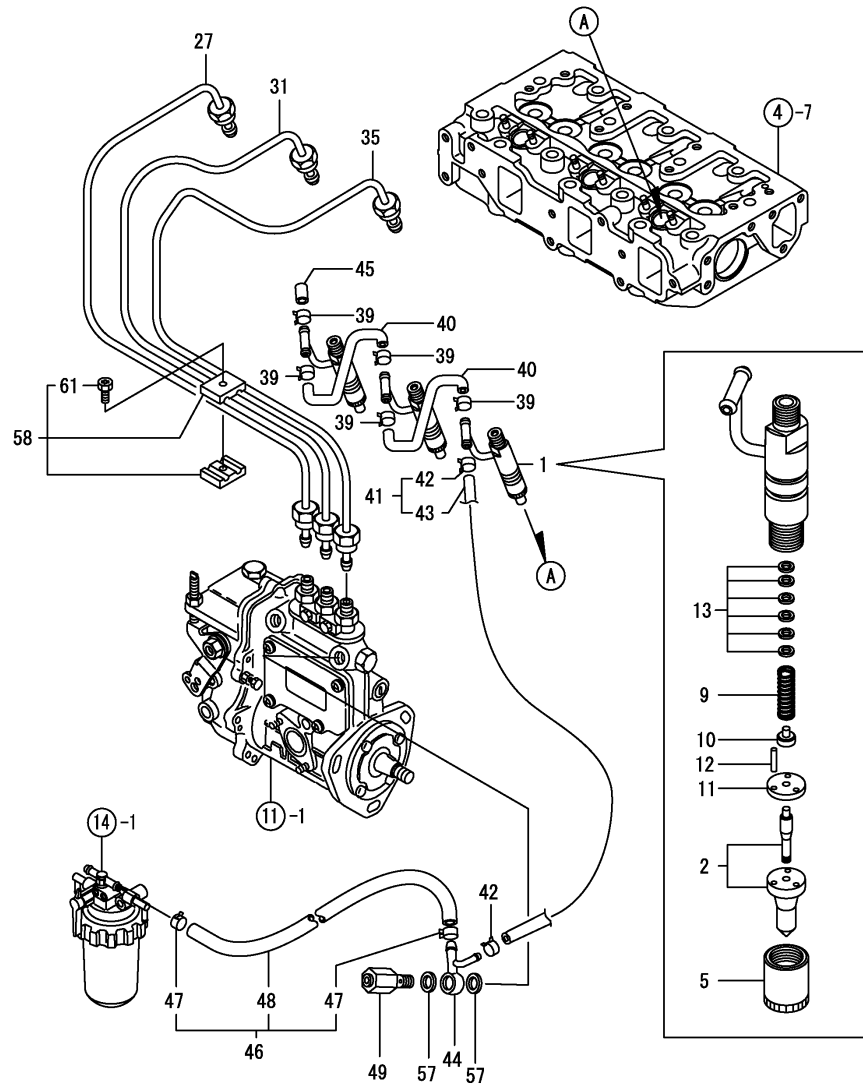

(A)=3TNE84-EIKC

(B)=

(C)=

(D)=

(E)=

(F)=

No.	Lev.	Parts No.	Description	Q'ty						I	R
				(A)	(B)	(C)	(D)	(E)	(F)		
1	1	729503-53100	VALVE ASSY,INJECTION	3							
1-1	1	729609-53100	VALVE ASSY,INJECTION	3							N
(A=EXXXXX)											
2	2	129503-53000	VALVE ASSY,INJECTION	3							
2-1	2	129609-53000	VALVE ASSY,INJECTION	3							N
(A=EXXXXX)											
5	2	114250-53080	NUT, NOZZLE D16.95	3							
9	2	114250-53120	SPRING, NOZZLE	3							
10	2	114250-53130	SEAT, SPRING	3							
11	2	114250-53140	PLATE	3							
12	2	114250-53210	PIN	6							
13	2	114250-53400	SHIM SET	3							
27	1	129001-59910	PIPE ASSY, INJECTION	1							
31	1	129001-59920	PIPE ASSY, INJECTION	1							
35	1	129001-59930	PIPE ASSY, INJECTION	1							
39	1	124066-59100	CLIP, HOSE 8	5							
40	1	121250-59550	PIPE, FUEL D8X120	2							
41	1	119840-59500	PIPE ASSY, RETURN	1							
42	2	124066-59100	CLIP, HOSE 8	2							
43	2	119840-59560	PIPE, FUEL RETURN	1							
44	1	119840-59570	JOINT	1							
45	1	129150-59580	CAP	1							
46	1	129210-59130	PIPE ASSY, FUEL	1							
47	2	124766-59050	CLIP, HOSE 12	2							
48	2	105025-59750	PIPE, FUEL	1							
49	1	129100-59951	VALVE ASSY, CHECK	1							
49-1	1	119813-59950	VALVE ASSY, CHECK	1							N
(A=E70781)											
57	1	22190-120002	WASHER, SEAL 12	2							
58	1	119305-59120	RETAINER, PIPE	2							
61	2	129150-59131	BOLT, M4X14	2							

Fig.14. FUEL LINE

(A)=3TNE84-EIKC

(B)=

(C)=

(D)=

(E)=

(F)=

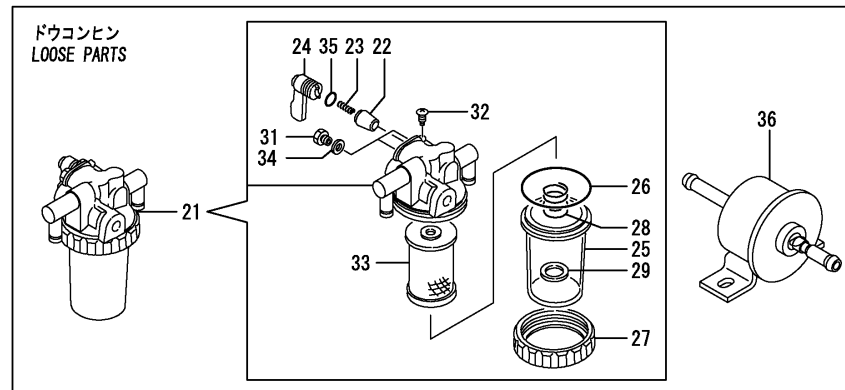
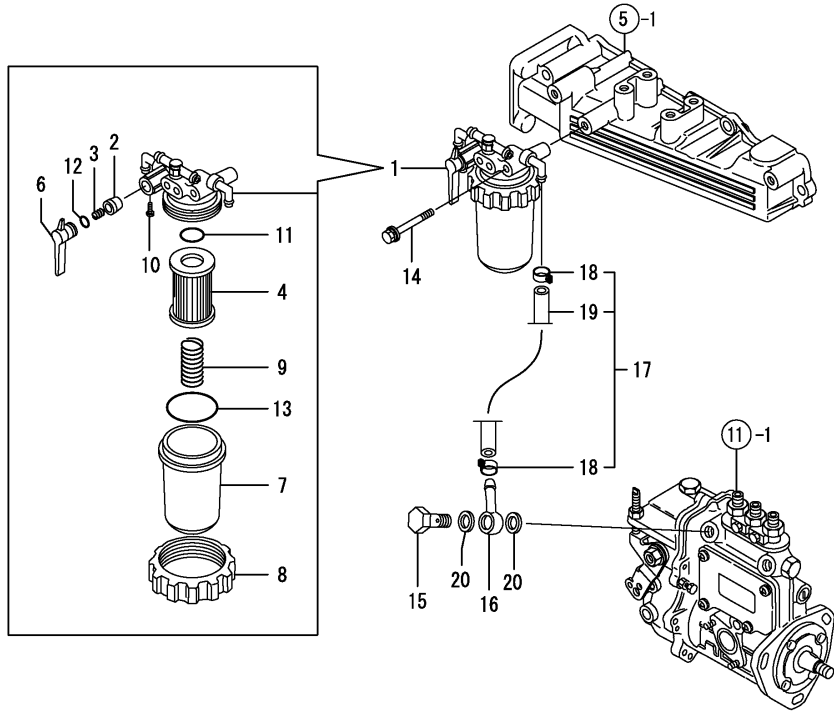

No.	Lev.	Parts No.	Description	Qty						I	R
				(A)	(B)	(C)	(D)	(E)	(F)		
1	1	129052-55620	FILTER ASSY, FUEL	1							
2	2	104200-55321	VALVE, TAPER	1							
3	2	104200-55330	SPRING, VALVE	1							
4	2	129100-55650	ELEMENT	1							
6	2	129100-55670	LEVER	1							
7	2	129100-55680	CUP, STRAINER	1							
8	2	129100-55690	RING, RETAINING	1							
9	2	129100-55700	SPRING	1							
10	2	104200-55750	SCREW, M4	1							
11	2	24311-000160	O-RING, 1AP16.0	1							
12	2	24311-240100	O-RING, 1AP10A	1							
13	2	24321-000650	O-RING, 1AG65.0	1							
14	1	26014-080702	BOLT, M8X 70	1							
15	1	103854-39140	BOLT, PIPE JOINT	1							
16	1	101304-59020	JOINT, PIPE 12	1							
17	1	129210-59040	PIPE ASSY, FUEL	1							
18	2	124766-59050	CLIP, HOSE 12	2							
19	2	129555-59510	PIPE, D13/7.5X180	1							
20	1	22190-120002	WASHER, SEAL 12	2							
21	1	129335-55700	SEPARATOR ASSY, WATER	1							
22	2	104200-55321	VALVE, TAPER	1							
23	2	104200-55330	SPRING, VALVE	1							
24	2	104200-55341	HANDLE	1							
25	2	124064-55510	COVER	1							
26	2	102103-55520	O-RING	1							
27	2	110250-55610	RING, RETAINING	1							
28	2	121257-55720	SPRING	1							
29	2	121257-55731	FLOAT	1							
31	2	101720-55750	PLUG, 6	2							
32	2	104200-55750	SCREW, M4	1							
33	2	171081-55910	SCREEN	1							
34	2	23418-060000	GASKET, 6X1.0	2							
35	2	24311-240100	O-RING, 1AP10A	1							
36	1	119225-52102	PUMP ASSY, FUEL FEED	1							

Fig.15. STARTING MOTOR

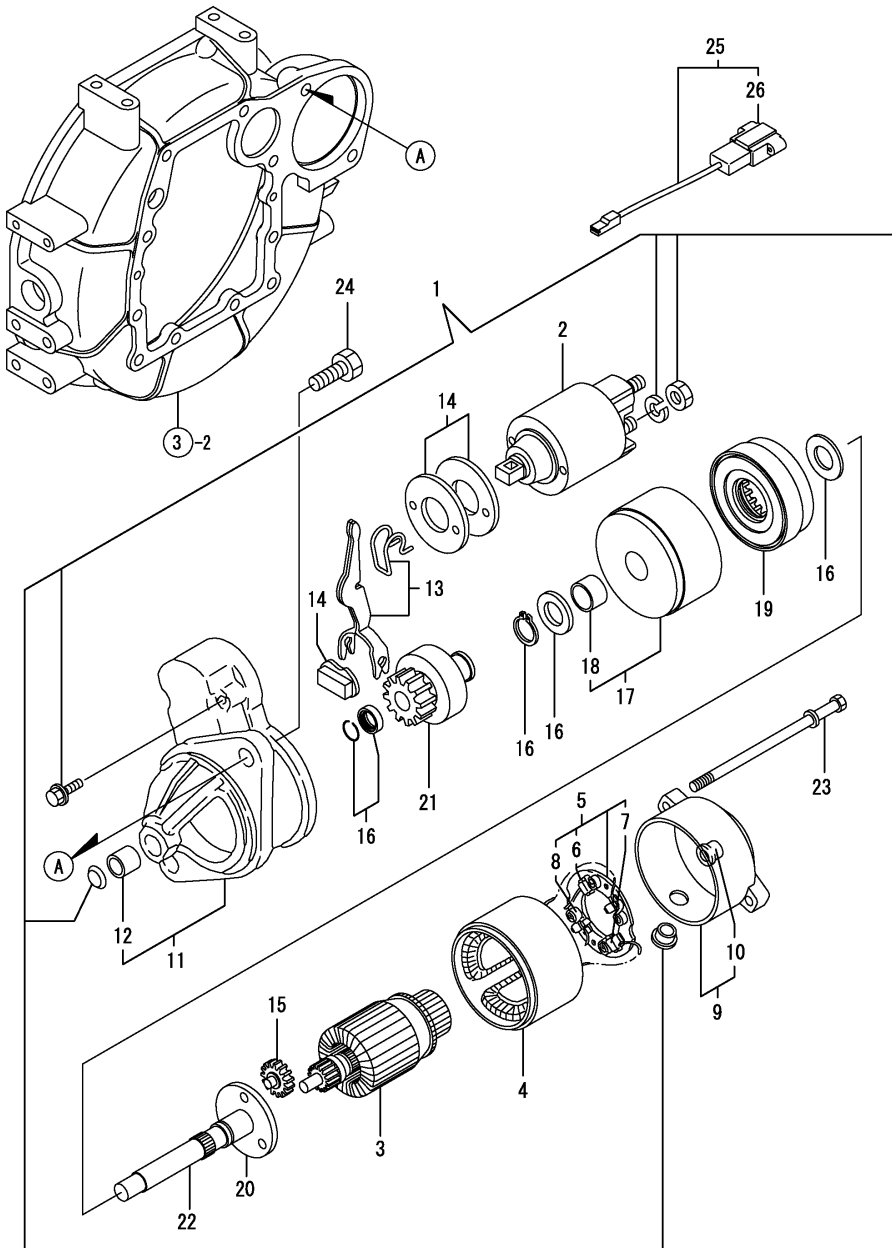

(A)=3TNE84-EIKC

(B)=

(C)=

(D)=

(E)=

(F)=

No.	Lev.	Parts No.	Description	Q'ty						I	R
				(A)	(B)	(C)	(D)	(E)	(F)		
1	1	129608-77010	STARTER, S114-817A	1							
2	2	129698-77020	MAGNETIC SWITCH ASSY	1							
3	2	129698-77100	ARMATURE ASSY	1							
3-1	2	129698-77101	ARMATURE ASSY	1							N
		(A=E70780)									
4	2	129608-77110	YOKE ASSY	1							
5	2	129698-77120	HOLDER ASSY, BRUSH	1							
6	3	129698-77140	BRUSH(+)	1							
7	3	129698-77130	BRUSH(-)	2							
8	3	129698-77150	SPRING, BRUSH	4							
9	2	129698-77160	COVER ASSY, REAR	1							
9-1	2	129698-77161	COVER ASSY	1							N
		(A=E70780)									
10	3	129698-77170	BEARING	1							
11	2	129698-77260	HOUSING ASSY, GEARS	1							
12	3	X2114535200	METAL, STARTER	1							
13	2	129698-77270	LEVER SET, SHIFT	1							
14	2	129698-77280	COVER KIT	1							
15	2	129698-77240	GEAR	3							
16	2	129698-77250	WASHER SET	1							
17	2	129698-77180	BRACKET	1							
18	3	129698-77190	BRACKET	1							
19	2	129698-77200	GEAR, INTERNAL	1							
20	2	129698-77210	BRACKET	1							
21	2	129698-77220	PINION ASSY	1							
22	2	129698-77230	SHAFT(PINION	1							
23	2	124195-77770	THROUGH BOLT	2							
24	1	26116-120252	BOLT, M12X 25 PLATED	2							
25	1	129052-77951	CONNECTOR, STARTER	1							
26	2	129052-77960	HOUSING	1							

Fig.16. GENERATOR

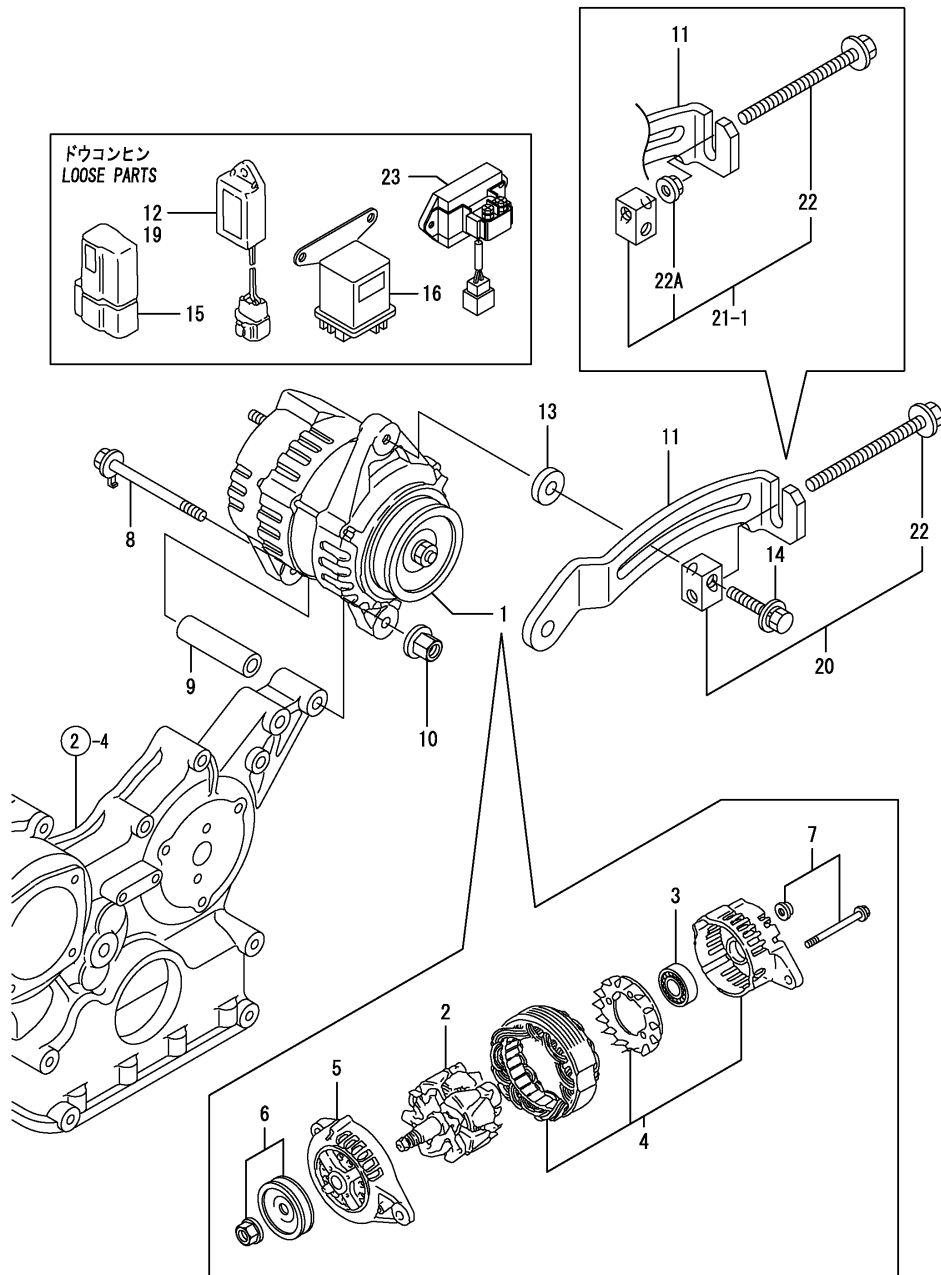

(A)=3TNE84-EIKC

(B)=

(C)=

(D)=

(E)=

(F)=

No.	Lev.	Parts No.	Description	Q'ty						I	R
				(A)	(B)	(C)	(D)	(E)	(F)		
1	1	119836-77201	GENERATOR (AC)	1							
2	2	129612-77700	ROTOR ASSY	1							
3	2	129612-77710	BEARING, BALL	1							
4	2	119836-77920	BRACKET ASSY	1							
5	2	129612-77730	BRACKET ASSY, FILTER	1							
6	2	129612-77740	PULLEY	1							
7	2	129612-77750	SCREW KIT	1							
8	1	129136-77251	BOLT, M8X110	1							
9	1	119820-77340	PIECE, DISTANCE	1							
10	1	129612-77260	NUT, ALTERNATOR	1							
11	1	129231-77330	ADJUSTER	1							
12	1	129211-77920	TIMER	1							
13	1	106500-44810	SPACER	1							
14	1	26014-080452	BOLT, M8X 45	1							
14-1	1	26106-080552	BOLT, M8X 55 PLATED	1							N
(A=E70781)											
15	1	119643-66900	DIODE	1							
16	1	119650-77910	RELAY ASSY, GLOW	1							
19	1	128300-77920	TIMER	1							
20	1	119624-77350	BLOCK, ADJUSTER	1							
20-1	1	119624-77351	BLOCK ASSY, ADJUSTER	1							N
(A=E70781)											
22	2	26106-081004	BOLT, M8X100 PLATED	1							
22A	2	26306-080002	NUT, M8	1							W
(A=E70781)											
23	1	129136-77101	RELAY, SAFETY	1							

Fig.17. GASKET SET

(A)=3TNE84-EIKC

(B)=

(C)=

(D)=

(E)=

(F)=

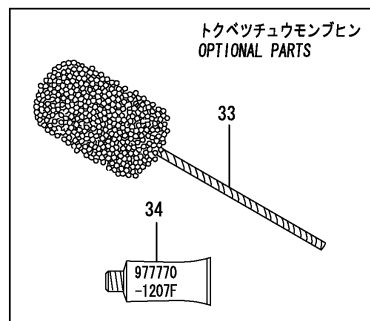
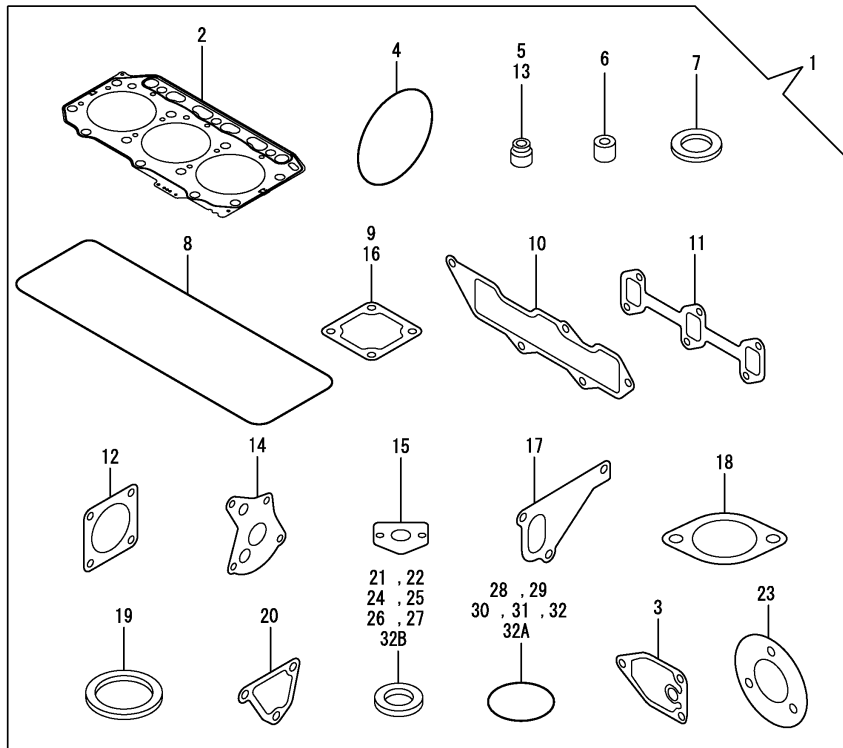

No.	Lev.	Parts No.	Description	Q'ty						I	R
				(A)	(B)	(C)	(D)	(E)	(F)		
1	1	729002-92830	GASKET SET	1							1
1-1	1	729002-92831	GASKET SET	1							N 1
(A=EXXXXX)											
2	2	129002-01331	GASKET, HEAD	1							
3	2	129150-35111	GASKET	1							
4	2	121850-51960	O-RING	1							
5	2	124460-11340	SEAL, VALVE STEM	3							
6	2	119625-11870	PROTECTOR, NOZZLE	3							
7	2	119625-11880	SEAT, NOZZLE	3							
8	2	129001-11310	GASKET, BONNET	1							
9	2	129150-77511	GASKET	1							
10	2	129001-12110	GASKET, MANIFOLD	1							
11	2	129150-13110	GASKET	1							
12	2	124701-11911	GASKET, SILENCER	1							
13	2	121400-11340	SEAL, VALVE STEM	3							
14	2	129150-32020	GASKET, PUMP	1							
15	2	129150-35041	GASKET	1							
15-1	2	129150-35042	GASKET	1							N
(A=E70781)											
16	2	129100-77510	GASKET, AIR HEATER	1							
17	2	129486-42021	GASKET, WATER PUMP	1							
18	2	129795-49551	GASKET	1							
19	2	129150-49811	GASKET, THERMOSTAT	1							
20	2	124395-49840	GASKET	1							
21	2	129155-52050	GASKET	1							
22	2	22190-080002	WASHER, SEAL 6	6							
23	2	103954-13201	GASKET, SILENCER	2							
24	2	22190-100002	WASHER, SEAL 10	2							
25	2	22190-120002	WASHER, SEAL 12	4							
26	2	124465-44950	GASKET, 16	1							
27	2	129150-49360	GASKET	1							
28	2	24311-000120	O-RING, 1AP12.0	3							
29	2	24311-000160	O-RING, 1AP16.0	3							
29-1	2	24311-000160	O-RING, 1AP16.0	1							K
(A=E70780)											
30	2	24311-000320	O-RING, 1AP32.0	2							
31	2	24341-000240	O-RING, 1AS24.0	1							
32	2	129486-42140	O-RING, G30	1							
32A	2	119609-32040	O-RING, P16	2							W
(A=E70780)											
32B	2	22190-220002	WASHER, SEAL 22	1							W
(A=E70781)											
33	1	129400-92420	FLEX HORN	1							1
34	1	977770-1207F	GASKET.LIQUID	1							1

Remarks

(1) OPTIONAL PARTS.

Parts No. Index

Parts No.	Fig. No.	Ref. No.
101304-59020	14	16
101720-55750	14	31
102103-55520	14	26
103854-39140	14	15
103954-13201	6	8
		18
	17	23
104200-55321	14	2
		22
104200-55330	14	3
		23
104200-55341	14	24
104200-55750	14	10
		32
105025-59750	13	48
106500-44810	16	13
110250-55610	14	27
114250-53080	13	5
114250-53120	13	9
114250-53130	13	10
114250-53140	13	11
114250-53210	13	12
114250-53400	13	13
119131-18320	6	2
119225-52102	14	36
119233-77931	12	82
119233-77932	12	82 -1
119305-59120	13	58
119609-32040	2	14 -1
	17	32 A
119620-01750	3	3
119620-49290	10	35
119624-77350	16	20
119624-77351	16	20 -1
119625-11870	4	25
	17	6
119625-11880	4	26
	17	7
119625-11900	4	27
119640-01640	3	9 -1
119643-66900	16	15
119650-77910	16	16
119660-61901	12	76
119717-51420	11	86 -1
119717-51500	11	45 -1
119802-11280	4	41 -1
119802-13750	6	17 -1
119808-12520	5	19
119808-12540	5	21
119810-51040	11	6

Parts No.	Fig. No.	Ref. No.
119813-59950	13	49 -1
119820-77340	16	9
119831-42290	10	20
119836-77201	16	1
119836-77920	16	4
119840-59500	13	41
119840-59560	13	43
119840-59570	13	44
119865-21600	8	16
119866-12540	5	20
119908-61501	12	32
119910-12210	5	6
119910-12560	5	7
120130-11860	4	11
120323-61470	12	81
121023-01550	2	25
121023-01551	2	25 -1
121111-21501	8	12
121250-59550	13	40
121252-39450	9	29
121256-44600	10	34
121257-55720	14	28
121257-55731	14	29
121267-44760	10	23
121400-11340	4	22
	17	13
121450-01560	2	6
121450-42450	10	30
121450-44531	10	40
121470-44581	10	42
121520-34810	9	14
121550-23200	8	30
121850-21680	8	11
121850-51960	2	13
	17	4
122117-51560	11	50
122710-51090	11	10
123900-13610	6	7 -1
123900-13630	6	6 -1
124064-55510	14	25
124066-59100	13	39
		42
124160-01751	2	7
	4	44
124160-01910	1	5
124160-11360	4	50
124160-39140	9	21
124195-77770	15	23
124240-01871	2	8
124395-49840	10	16

Parts No.	Fig. No.	Ref. No.
124395-49840	17	20
124450-44550	10	33
124450-44560	10	41
124460-11340	4	23
	17	5
124465-44950	10	31
	17	26
124550-51350	11	32
124550-51370	11	33
124550-59820	9	27
124550-59830	9	26
124550-66370	12	59
124701-11911	6	3
	17	12
124736-07900	4	5
124766-59050	13	47
	14	18
124950-51190	11	17
128300-77920	16	19
129001-01250	1	12
129001-02930	1	18
129001-02931	1	18 -1
129001-11310	4	48
	17	8
129001-11340	4	49
129001-11351	4	45
129001-11700	4	7
129001-12100	5	1
129001-12110	5	3
	17	10
129001-21100	8	1
129001-32001	9	1
129001-35300	9	18
129001-42003	10	2
129001-42004	10	2 -1
129001-42040	10	17
129001-59910	13	27
129001-59920	13	31
129001-59930	13	35
129001-91841	2	21
129002-01331	1	25
	17	2
129002-22081	8	17
129002-22500	8	19
129002-22901	8	33
129002-22950	8	35
129052-55620	14	1
129052-61050	12	4
129052-61051	12	4 -1
129052-61060	12	5

Parts No.	Fig. No.	Ref. No.
129052-61070	12	6
129052-61071	12	6 -1
129052-61390	12	31
129052-77951	15	25
129052-77960	15	26
129100-01580	3	1
		15
129100-01640	3	16
129100-01730	3	6
129100-01760	3	8
129100-11100	4	17
129100-11110	4	18
129100-11112	4	18 -1
129100-13110	6	4
129100-23910	8	29
129100-25061	7	10
129100-35301	9	16
129100-51560	11	51 -1
129100-51570	11	50 -1
129100-52200	11	95
129100-55650	14	4
129100-55670	14	6
129100-55680	14	7
129100-55690	14	8
129100-55700	14	9
129100-59951	13	49
129100-61400	12	17
129100-61440	12	115
129100-61650	12	78
129100-77500	5	11
129100-77501	5	11 -1
129100-77510	5	12
	17	16
129129-14580	7	3
129130-13560	6	9
129136-13520	6	10
129136-77101	16	23
129136-77251	16	8
129150-01200	1	24
129150-02020	1	7
129150-02450	7	4
129150-02870	1	26
129150-02871	1	26 -1
129150-02930	1	21
129150-02931	1	21 -1
129150-02940	1	29
129150-02941	1	29 -1
129150-03100	2	11
	4	53
129150-11230	4	38

Parts No. Index

Parts No.	Fig. No.	Ref. No.
129150-11280	4	33
129150-11290	4	34
129150-11370	4	24
129150-11750	4	40
129150-11810	4	13
129150-13110	6	5
	17	11
129150-14101	7	7
129150-14200	7	1
129150-14400	7	2
129150-21200	8	5
129150-23600	8	31
129150-23601	8	31 -1
129150-23610	8	39
129150-23611	8	39 -1
129150-25101	7	11
129150-25301	7	17
129150-25920	7	14
129150-25931	7	16
129150-32020	9	30
	17	14
129150-35041	9	15
	17	15
129150-35042	9	15 -1
	17	15 -1
129150-35101	9	36
129150-35111	9	17
	17	3
129150-35153	9	33
129150-35350	9	34
129150-39450	9	22
129150-49360	10	1
	17	27
129150-49811	10	28
	17	19
129150-59131	13	61
129150-59580	13	45
129150-77511	5	13
	17	9
129155-11241	4	30
129155-11260	4	31
129155-11270	4	32
129155-42350	10	21
129155-49800	10	27
129155-49801	10	27 -1
129155-51020	11	5
129155-51050	11	8
129155-51051	11	8 -1
129155-51140	11	14
129155-51180	11	16

Parts No.	Fig. No.	Ref. No.
129155-51200	11	18
129155-51270	11	25
129155-51280	11	26
	12	2
129155-51320	11	30
129155-51340	11	31
129155-51370	11	34
129155-51380	11	35
129155-51390	11	36
129155-51400	11	37
129155-51410	11	38
129155-51420	11	39
129155-51450	11	40
129155-51500	11	45
129155-51521	11	46
129155-51530	11	47
129155-51540	11	48
129155-51550	11	49
129155-51570	11	52
129155-51580	11	53
129155-51591	11	54
129155-51600	11	55
129155-51701	11	74
129155-51711	11	75
129155-51751	11	76
129155-51760	11	77
129155-51761	11	77 -1
129155-51790	11	78
129155-51930	11	80
129155-51940	11	81
129155-52050	11	94
	17	21
129155-52051	11	94 -1
129155-61120	12	7
129155-61130	12	8
129155-61140	12	9
129155-61341	12	14
129155-61350	12	15
129155-61360	12	16
129155-61430	12	20
129155-61450	12	24
129155-61460	12	25
129155-61480	12	26
129155-61830	12	75
129155-61950	12	77
129156-51910	11	79
129202-22300	8	23
129208-51060	11	9
129208-54500	11	96
129209-61370	12	16 A

Parts No.	Fig. No.	Ref. No.
129209-61930	12	80 -1
129209-61970	12	82 A
129210-59040	14	17
129210-59130	13	46
129211-12540	5	17
129211-12590	5	18
129211-13600	6	11
129211-13610	6	12
129211-21590	8	13
129211-77920	16	12
129231-77330	16	11
129335-55700	14	21
129350-49560	10	25
129400-01520	2	5
129400-92420	17	33
129410-03090	4	1
129450-51300	11	27
129486-01670	3	19
129486-42021	10	14
	17	17
129486-42140	10	18
	17	32
129486-61201	12	10
129486-61540	12	51
129503-53000	13	2
129506-51100	11	11
129555-59510	14	19
129608-77010	15	1
129608-77110	15	4
129609-53000	13	2 -1
129612-01600	3	2
129612-77260	16	10
129612-77700	16	2
129612-77710	16	3
129612-77730	16	5
129612-77740	16	6
129612-77750	16	7
129698-77020	15	2
129698-77100	15	3
129698-77101	15	3 -1
129698-77120	15	5
129698-77130	15	7
129698-77140	15	6
129698-77150	15	8
129698-77160	15	9
129698-77161	15	9 -1
129698-77170	15	10
129698-77180	15	17
129698-77190	15	18
129698-77200	15	19

Parts No.	Fig. No.	Ref. No.
129698-77210	15	20
129698-77220	15	21
129698-77230	15	22
129698-77240	15	15
129698-77250	15	16
129698-77260	15	11
129698-77270	15	13
129698-77280	15	14
129795-01780	3	18
129795-01800	2	4
129795-01950	2	10
129795-02411	1	10
129795-02412	1	10 -1
129795-11120	4	19
129795-11180	4	20
129795-21661	8	10
129795-49551	10	26
	17	18
129916-49740	10	12 -1
158552-61900	12	67 -1
171051-01921	1	6
171056-49351	10	32
171064-44510	10	38
171081-55910	14	33
171301-01640	3	9
171340-21650	8	9
171340-44740	10	22
171340-77520	5	14
171353-61550	12	83
171353-61710	12	79
171420-34820	9	32
174307-51170	11	15
174307-51560	11	51
174307-51700	12	33
194990-22060	6	14
22117-040000	12	60
22190-060003	12	61
22190-080002	2	12
		23
	9	28
		37
	17	22
22190-100002	9	38
	12	62
	17	24
22190-120002	12	63
	13	57
	14	20
	17	25
22190-160002	11	91

Parts No. Index

Parts No.	Fig. No.	Ref. No.
22190-220002	3	11 -1
	17	32 B
22217-050000	11	82
22217-060000	11	83
22217-120000	11	98
22252-000260	8	24
22287-120000	12	64
22351-040010	8	8
22351-050010	11	84
22351-060012	4	28
22372-040000	12	65
22512-070140	7	8
	8	6
23000-060000	5	8
23065-070225	10	43
23414-120016	12	82 B
23418-060000	14	34
23876-010000	1	11
23876-030000	10	12
23887-100002	12	66
24101-063034	11	85
24311-000120	4	51
	17	28
24311-000160	2	14
	9	35
	14	11
	17	29
		29 -1
24311-000320	2	15
	4	52
	17	30
24311-240100	14	12
		35
24316-000150	11	33 -1
24321-000650	14	13
24341-000160	11	86
24341-000240	2	26
	17	31
24341-000250	3	11
24341-000280	12	67
26013-080222	5	9
		10
26014-060302	10	24
26014-080452	16	14
26014-080702	14	14
26022-050122	11	87
26022-060162	11	88
26106-060102	12	68
		69
		70

Parts No.	Fig. No.	Ref. No.
26106-060142	12	71
26106-060162	2	27
26106-060202	12	72
26106-080122	2	16
26106-080142	4	6
	7	9
26106-080162	2	17
		24
	3	12
	10	19
26106-080202	2	18
	5	4
	9	19
	10	29
26106-080252	3	13
	4	42
26106-080352	3	20
	6	15
	9	20
26106-080402	5	15
26106-080452	2	19
	3	14
		14 -1
	7	15
26106-080502	3	22
	4	43
26106-080552	2	20
	16	14 -1
26106-080602	10	15
26106-080802	5	5
		16
	6	6
26106-081004	16	22
26106-100162	6	16
26116-050302	11	89
26116-120252	15	24
26206-100252	3	4
26206-100302	3	5
26216-060202	4	15
26216-080652	6	17
26216-080802	6	7
26226-080182	4	41
26306-080002	2	22 -1
	6	1 -1
		13 -1
	16	22 A
26306-100002	6	14 -1
26366-060002	4	29
26366-080002	2	22
	6	1

Parts No.	Fig. No.	Ref. No.
26366-080002	6	13
	12	114
26450-060252	9	31
26687-120002	12	80
26716-060002	11	90
26716-120002	11	99
26736-120002	12	72 A
26756-060002	12	73
26776-120002	12	74
		74 -1
27241-120000	1	13
27241-300000	1	14
27241-400000	4	16
27310-080001	4	21
719810-01500	2	1
729002-01560	1	1
729002-92830	17	1
729002-92831	17	1 -1
729231-51450	11	1
729402-11650	4	37
729402-23100	8	25
729503-53100	13	1
729609-53100	13	1 -1
977770-1207F	2	9
	3	21
	17	34
X2114535200	15	12

Parts No.	Fig. No.	Ref. No.
-----------	----------	----------