

OCD10-M68200EN

PREFACE

1. This parts catalog is the Second edition of 4TNE98-TB for Takeuchi Mfg. Co., Ltd.
2. This parts catalog does not contain the technical data needed for maintenance service.
3. The illustrations used in this parts catalog have been simplified for clarity.

Pub. No.: 000Y00D6820

Published: May., 1999

4. Model name

Engine model	Vehicle		Vehicle made by
	Products	Model name	
4TNE98-TB	EXCAVATOR	TB70FR	Takeuchi Mfg. Co., Ltd.

5. The contents of this parts catalog are subject to change without prior notice.

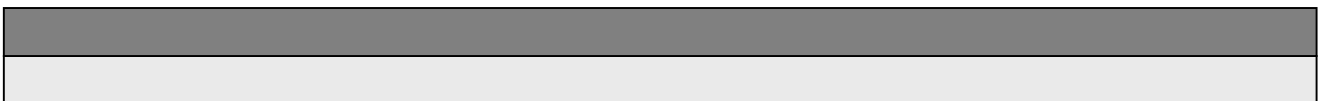

Directions for the Parts Catalog.

1. The parts stipulated in this Parts Catalog are not necessarily standard equipped parts.
2. Parts may change without prior notice.
3. The following is an example of the Parts Catalog format.

OCF10-G21601 29. FUEL INJECTION PUMP(W/BOOST)

REF.	LEV.	PARTS NO.	DESCRIPTION	Q'TY						I	R
				(A)	(B)	(C)	(D)	(E)	(F)		
1	1	729595-51390	FUEL INJECTION PUMP	1	1	1	1	1			1
1-1	1	729595-51391	FUEL INJECTION PUMP	1	1	1	1	1		N	1
		(A=E00185) (B=E00200)									
3	2	26022-060162	SCREW M 6X 16	9	9	9	9	9			
3-1	2	26022-060162	SCREW M 6X 16	4	4	4	4	4		K	
		(A=E00156) (B=E00156) (C=E00156) (D=E00156) (E=E00156)									
4	2	129470-51040	CAMSHAFT	1	1	1	1	1			
5	2	122710-51050	BEARING, ROLLER	2	2	2	2	2			
6	2	129470-51060	RETAINER	1	1	1	1	1			

Remarks

(1) BOOST COMPEMSATOR TYPE. OPTIONAL PART, TO E00155,(4JH-DT, 4JH-DTZ

① Ref. No.

The Ref. No. listed may not be in accordance with the illustration Ref. No.

(Ex.) Illustration No.

List Ref No.

1 1 (Before change) → 1-1 (After change)

For interchangeable symbols N, R and K, illustrations for new parts may be abbreviated.

② Lev. (Level)

Level indication

The numbers below indicate the level of relativity towards the main part.

1 ----- Main parts (Assembly parts)

2 ----- Sub component included in " 1 ".

3 ----- Sub component included in " 2 ".

Note) Parts that are not for sale are partially illustrated but not listed.

③ Interchangeability Mark

When a part change takes place, one of the following interchangeability symbols is indicated beside the part.

Symbol	Interchangeability	Contents note
N	Old $\begin{matrix} \leftarrow \text{Yes} \\ \text{No} \rightarrow \end{matrix}$ New	New Part is interchangeable for Old Part but Old Part is not interchangeable for New Part.
Q	Old $\begin{matrix} \leftarrow \text{No} \\ \text{Yes} \rightarrow \end{matrix}$ New	New Part is not interchangeable for Old Part but Old Part is interchangeable for New Part.
R	Old $\begin{matrix} \leftarrow \text{Yes} \\ \text{Yes} \rightarrow \end{matrix}$ New	New/ Old Parts are both interchangeable.
S	Old $\begin{matrix} \leftarrow \text{No} \\ \text{No} \rightarrow \end{matrix}$ New	New/ Old Parts are both not interchangeable.
W		Part newly added.
Z		Part discontinued.
F		Not interchangeable by a single part but interchangeable together with related parts.
K		Changes only for used parts quantities.

④ Effective Machine No.

When a part changes, the effective Machine No. will be indicated in the (A)-(F) column.

Product Symbol	Product No.	Product Symbol	Product No.
C	Clutch No. Compressor No.	F	Machine No. (Agricultural Equip.)
D	Drive No.	M	Machine No.
E	Engine No.		

Note 1) A date may follow the symbol. (Ex.) 1996.01

Note 2) "XXXXX" and "ZZZZZ" are for parts that could not be predicted or for engine models that could not be identified.

Note 3) (A=E00185) is the E (Engine Serial Number) for the column (A) model (in this case 4JH-DT) after the parts design change.

⑤ Remarks Mark

Figures or alphabets (symbols) are entered in the remarks column.

The comments (remarks) on parts that are indicated at the bottom of the illustration are the same symbols as those stated above.

Contents

Fig. No. Fig. Name

4TNE98-TB

1. CYLINDER BLOCK
2. GEAR HOUSING
3. FLYWHEEL HOUSING & OIL SUMP
4. CYLINDER HEAD & BONNET
5. SUCTION MANIFOLD & AIR CLEANER
6. EXHAUST MANIFOLD & SILENCER
7. CAMSHAFT & DRIVING GEAR
8. CRANKSHAFT & PISTON
9. LUB.OIL SYSTEM
10. COOLING WATER SYSTEM
11. FUEL INJECTION PUMP
12. GOVERNOR
13. FUEL INJECTION VALVE
14. FUEL LINE
15. ENGINE STOP DEVICE
16. STARTING MOTOR
17. GENERATOR
18. GASKET SET

Fig. No. Fig. Name

Fig.1. CYLINDER BLOCK

(A)=4TNE98-TB

(B)=

(C)=

(D)=

(E)=

(F)=

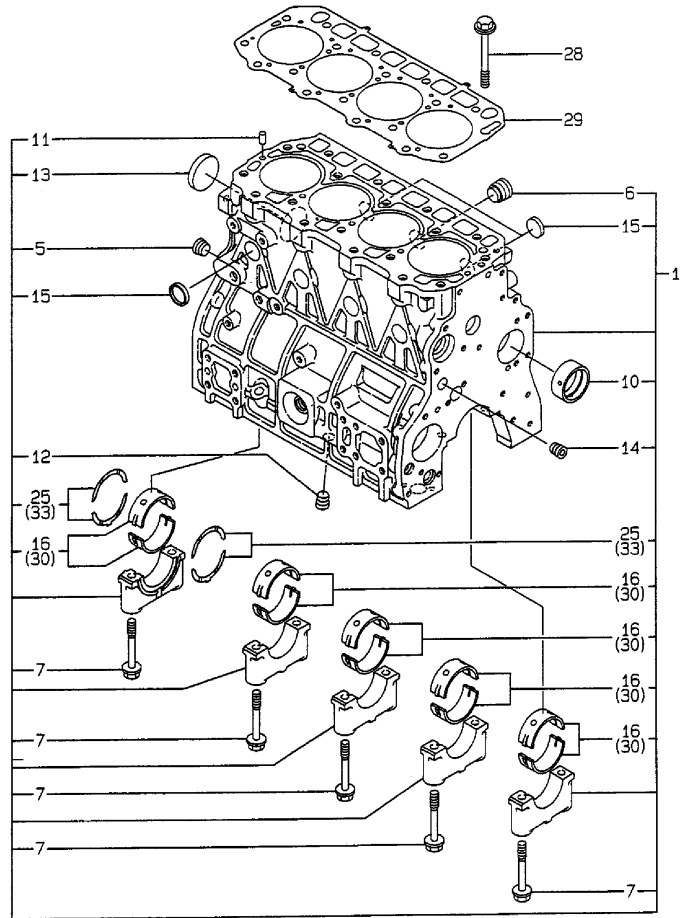

No.	Lev.	Parts No.	Description	Q'ty						I	R
				(A)	(B)	(C)	(D)	(E)	(F)		
1	1	729902-01560	BLOCK ASSY, CYLINDER	1							
5	2	23871-030000	PLUG, R03	1							
6	2	171051-01921	PLUG, NPTF1	1							
7	2	129900-02020	BOLT, METAL CAP	10							
10	2	129900-02410	BUSH, CAMSHAFT	1							
11	2	22351-060012	PIN, SPRING 6.0X12	2							
12	2	23871-030000	PLUG, R03	1							
13	2	27231-550000	PLUG 55	1							
14	2	23871-030000	PLUG, R03	1							
15	2	27241-300000	PLUG 30	8							
16	2	129900-02800	BEARING, MAIN	5							
25	2	129900-02930	BEARING, THRUST	2							
28	1	129900-01200	BOLT, HEAD	18							
29	1	129902-01330	GASKET, HEAD	1							
30	1	129900-02340	BEARING, 0.25 US	5							1
33	1	129900-02940	BEARING, THRUST 0.25	2							2

Remarks

- (1) UNDER-SIZED(U.S=0.25)PART.
- (2) OVER-SIZED(O.S=0.25)PART.

Fig.2. GEAR HOUSING

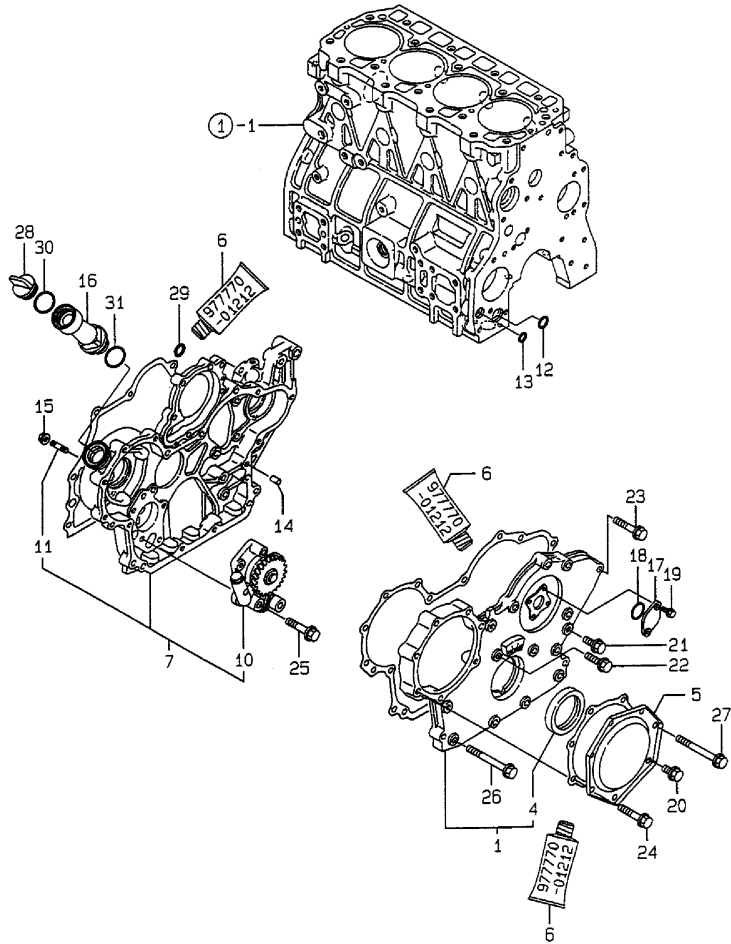

(A)=4TNE98-TB

(B)=

(C)=

(D)=

(E)=

(F)=

No.	Lev.	Parts No.	Description	Q'ty						I	R
				(A)	(B)	(C)	(D)	(E)	(F)		
1	1	729900-01570	COVER ASSY,GEAR CASE	1							
4	2	129900-01780	SEAL, OIL	1							
5	1	129951-01740	COVER	1							
6	1	977770-01212	GASKET, LIQUID	1							1
7	1	129900-01820	CASE ASSY, GEAR	1							
10	2	129900-32000	PUMP ASSY, OIL	1							
11	2	26216-100302	STUD, M10X 30	4							
12	1	129900-32030	O-RING, P20	1							
13	1	129900-32040	O-RING, P14	1							
14	1	129100-01580	PIN, M8X16	4							
15	1	26366-100002	NUT, M10	4							
16	1	171031-11741	PIPE	1							
17	1	121023-01550	COVER	1							
18	1	24341-000240	O-RING, 1AS24.0	1							
19	1	26106-060162	BOLT, M6X 16 PLATED	2							
20	1	26106-080162	BOLT, M8X 16 PLATED	1							
21	1	26106-080202	BOLT, M8X 20 PLATED	3							
22	1	26106-080302	BOLT, M8X 30 PLATED	1							
23	1	26106-080402	BOLT, M8X 40 PLATED	5							
24	1	26106-080402	BOLT, M8X 40 PLATED	5							
25	1	26106-080452	BOLT, M8X 45 PLATED	3							
26	1	129001-91810	BOLT, M8X70	6							
27	1	129001-91810	BOLT, M8X70	1							
28	1	124160-01751	COVER, FILLER	1							
29	1	24311-000070	O-RING, 1AP7.0	1							
30	1	24311-000320	O-RING, 1AP32.0	1							
31	1	24311-000320	O-RING, 1AP32.0	1							

Remarks

(1) OPTIONAL PART.

N:Old $\xrightarrow{\text{Yes}}$ New, Q:Old $\xrightarrow{\text{No}}$ New, R:Old $\xrightarrow{\text{Yes}}$ New, S:Old $\xrightarrow{\text{No}}$ New, W:Add, Z:Discontinued, F:Interchangeable by set, K:Q'ty Change

Fig.3. FLYWHEEL HOUSING & OIL SUMP

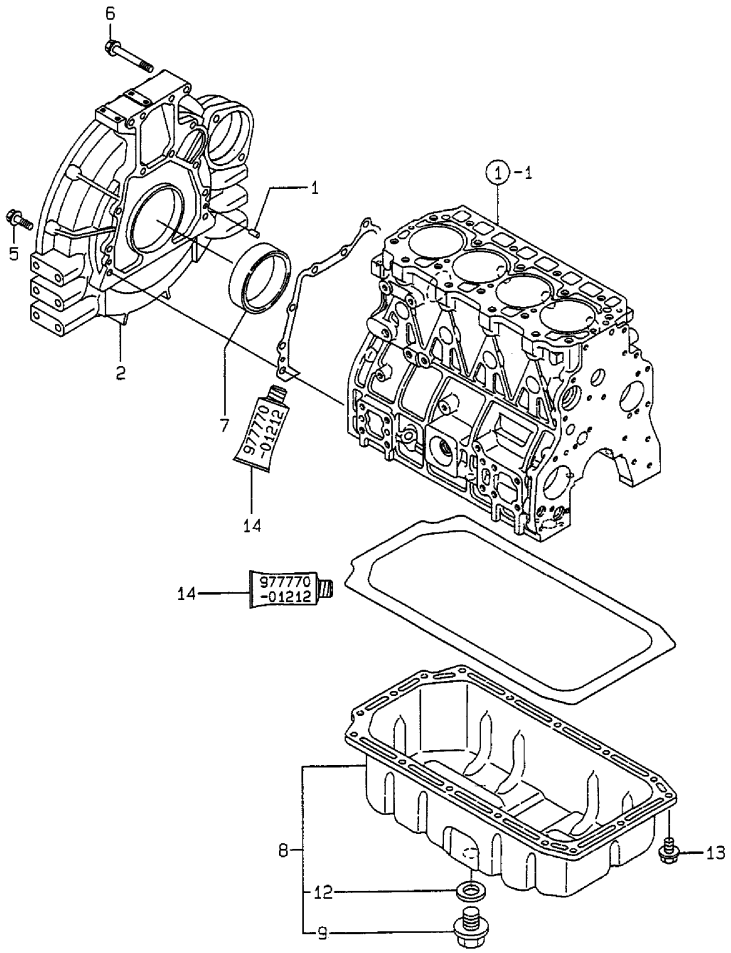

(A)=4TNE98-TB

(B)=

(C)=

(D)=

(E)=

(F)=

No.	Lev.	Parts No.	Description	Q'ty						I	R
				(A)	(B)	(C)	(D)	(E)	(F)		
1	1	129100-01580	PIN, M8X16	2							
2	1	129953-01620	HOUSING, FLYWHEEL	1							
5	1	26106-100352	BOLT, M10X 35 PLATED	9							
6	1	26206-100702	BOLT, M10X 70 PLATED	4							
7	1	124411-01780	SEAL, HTC95X115X12	1							
8	1	129953-01710	SUMP ASSY, OIL	1							
9	2	119640-01640	PLUG, DRAIN M22	1							
12	2	22190-220002	WASHER, SEAL 22	1							
13	1	26106-080122	BOLT, M8X 12 PLATED	21							
14	1	977770-01212	GASKET, LIQUID	1							1

Remarks
 (1) OPTIONAL PART.

Fig.4. CYLINDER HEAD & BONNET

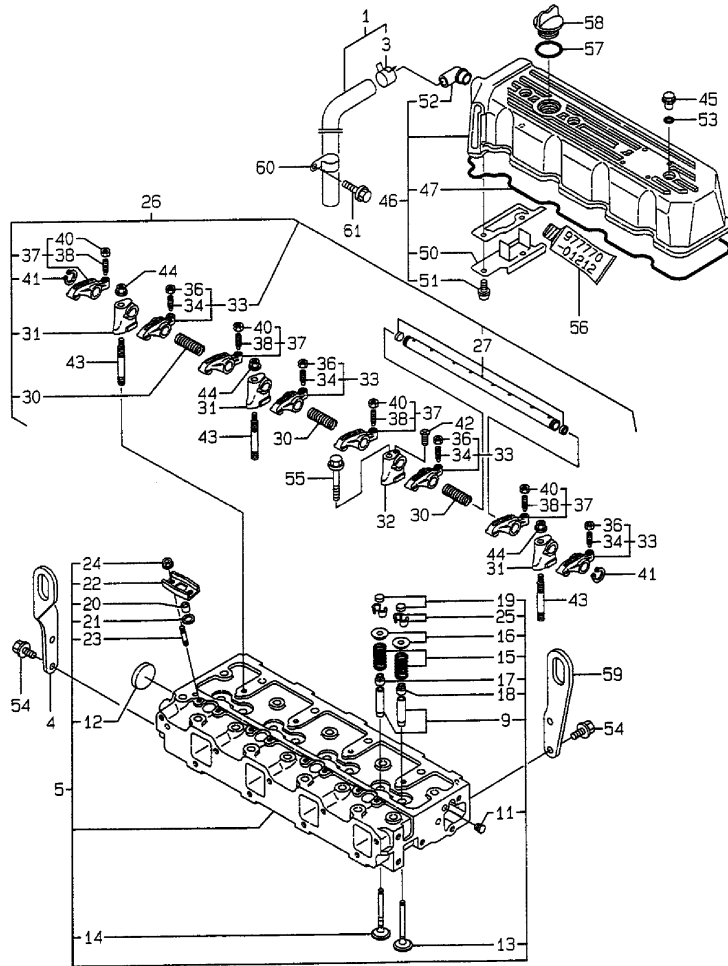

Remarks
 (1) REPAIR PART.
 (2) OPTIONAL PART.

(A)=4TNE98-TB
 (B)=
 (C)=

(D)=
 (E)=
 (F)=

No.	Lev.	Parts No.	Description	Q'ty						I	R
				(A)	(B)	(C)	(D)	(E)	(F)		
1	1	129953-03100	HOSE ASSY, BREATHER	1							
3	2	129960-03990	CLIP, HOSE 22	1							
4	1	129910-07900	LIFTER	1							
5	1	729900-11100	HEAD ASSY, CYLINDER	1							
9	2	129150-11810	GUIDE, VALVE	8							1
11	2	23871-005000	PLUG, R005	1							
12	2	27241-400000	PLUG, 40	1							
13	2	129900-11100	VALVE, INTAKE	4							
14	2	129900-11110	VALVE, EXHAUST	4							
15	2	129900-11120	SPRING, VALVE	8							
16	2	129795-11180	RETAINER, SPRING	8							
17	2	121400-11340	SEAL, VALVE STEM	4							
18	2	124460-11340	SEAL, VALVE STEM	4							
19	2	129150-11370	CAP, VALVE	8							
20	2	119625-11870	PROTECTOR, NOZZLE	4							
21	2	119625-11880	SEAT, NOZZLE	4							
22	2	119625-11900	RETAINER, NOZZLE	4							
23	2	26216-060202	STUD, M6X 20	8							
24	2	26366-060002	NUT, M6	8							
25	2	27310-080001	COTTER, 8	8							
26	1	129900-11200	SUPPORT ASSY, ARM	1							
27	2	129900-11240	SHAFT ASSY, ROCKER	1							
30	2	129900-11280	SPRING	3							
31	2	129900-11510	SUPPORT, ROCKER ARM	3							
32	2	129900-11520	SUPPORT, ROCKER ARM	1							
33	2	129900-11650	ARM, ROCKER	4							
34	3	129150-11230	SCREW, VALVE ADJUST	4							
36	3	129150-11750	NUT, M8	4							
37	2	129900-11660	ARM, ROCKER	4							
38	3	129150-11230	SCREW, VALVE ADJUST	4							
40	3	129150-11750	NUT, M8	4							
41	2	22242-000180	RING, 18	2							
42	2	26577-040162	SCREW, M4X16	1							
43	1	129900-11530	STUD	3							
44	1	26366-100002	NUT, M10	3							
45	1	124160-11360	KNOB	3							
46	1	129900-11350	BONNET ASSY, HEAD	1							
47	2	129900-11310	GASKET, BONNET	1							
50	2	129900-11600	PLATE, BAFFLE	1							
51	2	22857-500100	SCREW, 5X10	2							
52	2	119100-11330	ELBOW	1							
53	1	24311-000120	O-RING, 1AP12.0	3							
54	1	26106-080162	BOLT, M8X 16 PLATED	4							
55	1	26106-100652	BOLT, M10X 65 PLATED	1							
56	1	977770-01212	GASKET, LIQUID	1							2
57	1	24311-000320	O-RING, 1AP32.0	1							
58	1	124160-01751	COVER, FILLER	1							
59	1	129953-07910	LIFTER	1							
60	1	129910-03100	RETAINER, PIPE	1							
61	1	26106-080122	BOLT, M8X 12 PLATED	1							

Fig.5. SUCTION MANIFOLD & AIR CLEANER

(A)=4TNE98-TB

(B)=

(C)=

(D)=

(E)=

(F)=

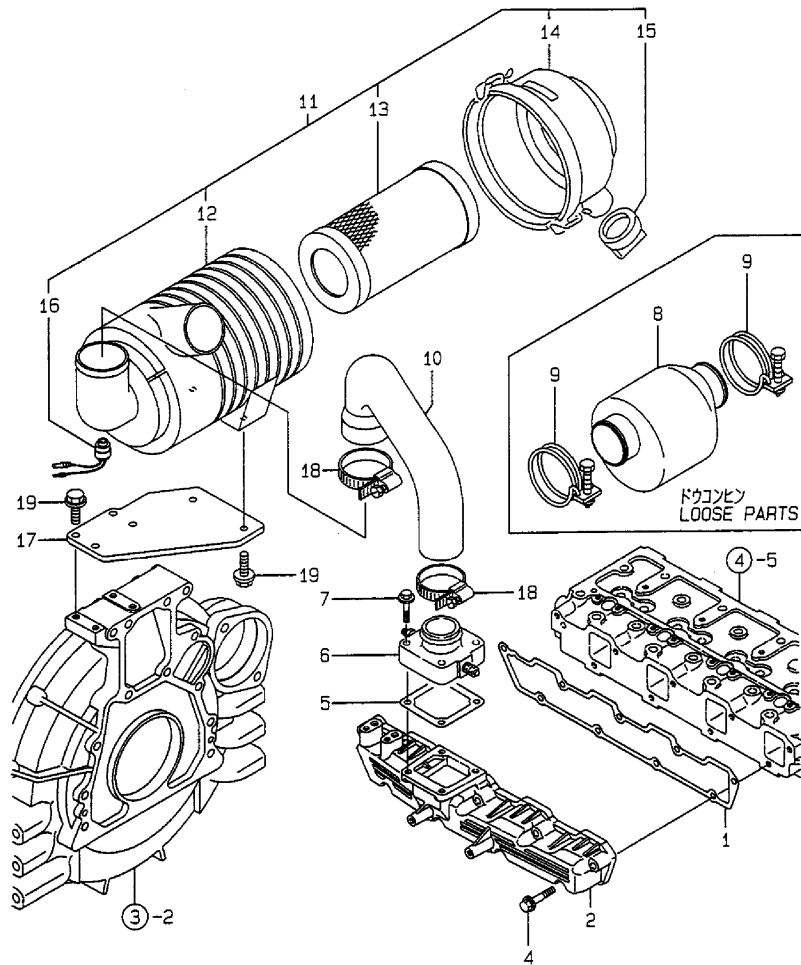

No.	Lev.	Parts No.	Description	Q'ty						I	R
				(A)	(B)	(C)	(D)	(E)	(F)		
1	1	129900-12050	GASKET, MANIFOLD	1							
2	1	129900-12100	MANIFOLD, AIR INTAKE	1							
4	1	26106-080452	BOLT, M8X 45 PLATED	9							
5	1	121850-77021	GASKET	1							
6	1	129915-77050	HEATER	1							
7	1	26106-080352	BOLT, M8X 35 PLATED	4							
8	1	119160-12060	SILENCER ASSY	1							
9	1	119005-12080	CLAMP, HOSE	2							
10	1	129953-12200	PIPE, AIR INTAKE	1							
11	1	129953-12520	CLEANER ASSY, AIR	1							
12	2	129953-12560	BODY	1							
13	2	129062-12560	ELEMENT	1							
14	2	129457-12530	COVER	1							
15	2	119808-12540	VALVE, UNLOADER	1							
16	2	119140-12680	INDICATOR	1							
17	1	129953-12540	STAY, AIR CLEANER	1							
18	1	23000-080000	CLAMP, 80	3							
19	1	26106-080202	BOLT, M8X 20 PLATED	6							

Fig.6. EXHAUST MANIFOLD & SILENCER

(A)=4TNE98-TB
(B)=
(C)=

(D)=
(E)=
(F)=

No.	Lev.	Parts No.	Description	Q'ty						I	R
				(A)	(B)	(C)	(D)	(E)	(F)		
1	1	129900-13200	MANIFOLD, EXHAUST	1							
3	1	129900-13251	GASKET	1							
4	1	26106-080802	BOLT, M8X 80 PLATED	6							
5	1	26216-080802	STUD, M8X 80	2							
6	1	26366-080002	NUT, M8	2							
7	1	129400-13201	GASKET, SILENCER	2							
8	1	23446-050000	GASKET 50	1							
9	1	119131-18320	STUD, M8X22	4							
10	1	119129-13500	SILENCER	1							

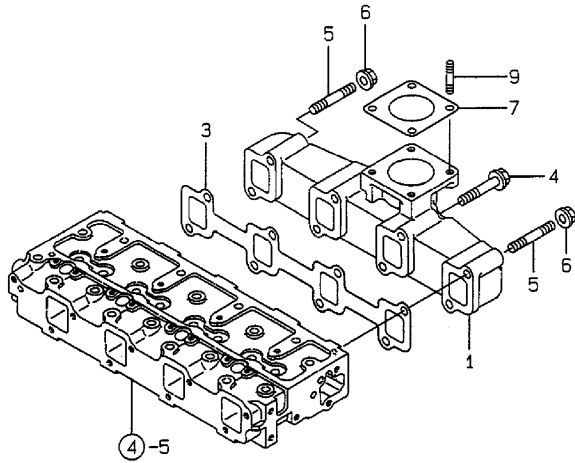
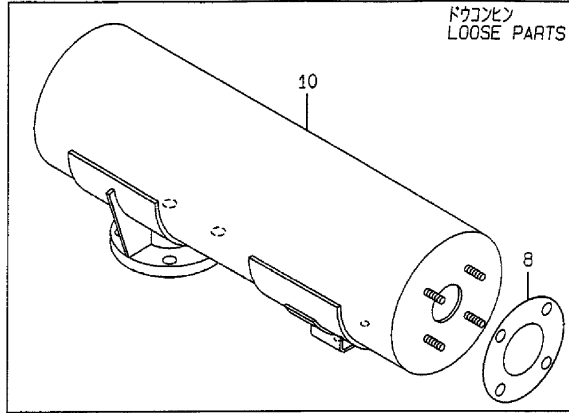
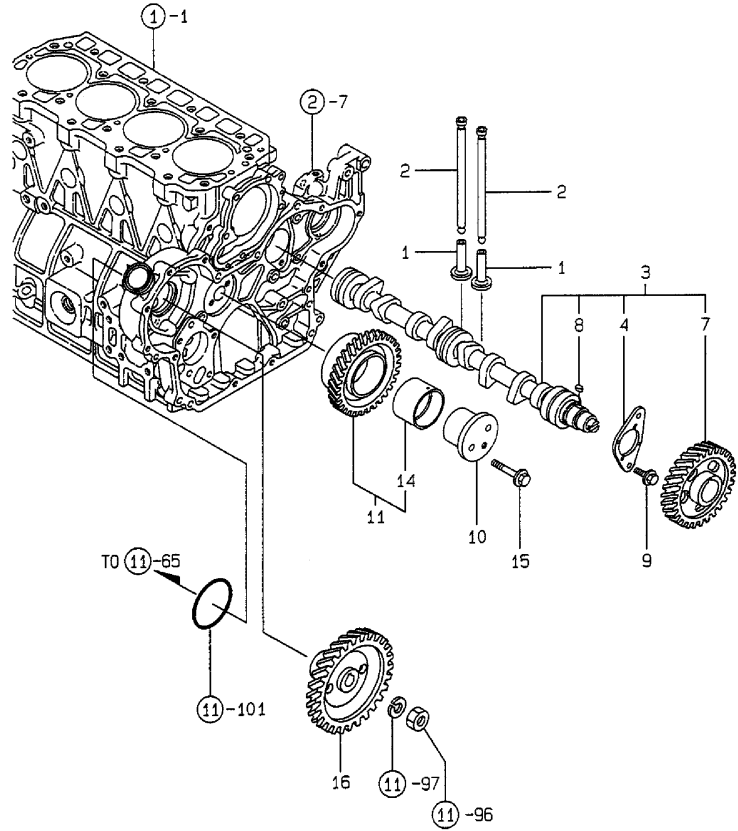

Fig.7. CAMSHAFT & DRIVING GEAR



(A)=4TNE98-TB

(B)=

(C)=

(D)=

(E)=

(F)=

No.	Lev.	Parts No.	Description	Q'ty						I	R
				(A)	(B)	(C)	(D)	(E)	(F)		
1	1	129150-14200	TAPPET	8							
2	1	129900-14400	ROD, PUSH	8							
3	1	129900-14580	CAMSHAFT ASSY	1							
4	2	129150-02450	BEARING, THRUST	1							
7	2	129900-14100	GEAR, CAMSHAFT	1							
8	2	22512-070140	KEY, 7X 14	1							
9	1	26106-080162	BOLT, M8X 16 PLATED	2							
10	1	129900-25060	SHAFT, IDLE	1							
11	1	129900-25100	GEAR ASSY, IDLE	1							
14	2	129150-25920	BUSH, IDLE GEAR	1							1
15	1	26106-080552	BOLT, M8X 55 PLATED	2							
16	1	129900-25900	GEAR, PUMP	1							

Remarks
(1) REPAIR PART.

Fig.8. CRANKSHAFT & PISTON

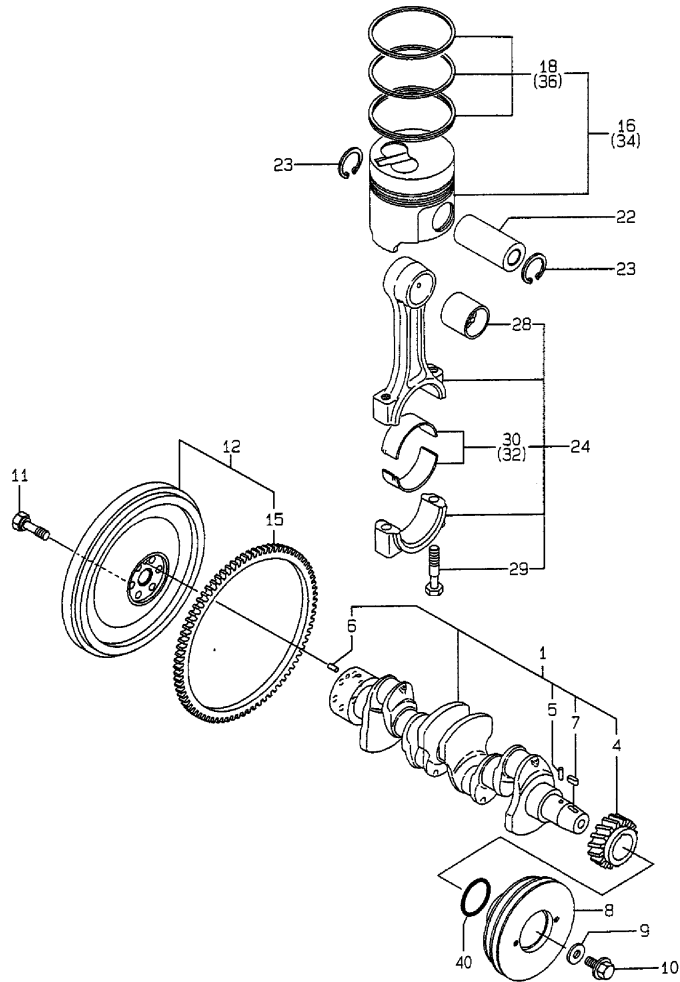

(A)=4TNE98-TB

(B)=

(C)=

(D)=

(E)=

(F)=

No.	Lev.	Parts No.	Description	Q'ty						I	R
				(A)	(B)	(C)	(D)	(E)	(F)		
1	1	129902-21000	CRANKSHAFT ASSY	1							
4	2	129900-21200	GEAR, CRANKSHAFT	1							
5	2	121850-21290	PIN	1							
6	2	121850-21920	PIN, M10X22	1							
7	2	22512-070140	KEY, 7X 14	1							
8	1	129953-21610	V-PULLEY	1							
8-1	1	129953-21611	V-PULLEY	1							N
(A=EXXXXX)											
9	1	129960-21640	WASHER	1							
10	1	121850-21680	BOLT	1							
11	1	121850-21130	BOLT, FLYWHEEL	6							
12	1	129953-21581	FLYWHEEL ASSY	1							
15	2	129900-21600	GEAR, RING	1							
16	1	129902-22080	PISTON ASSY, DI	4							
18	2	129903-22050	RING SET, PISTON	4							
22	1	120130-22301	PIN, PISTON	4							
23	1	22252-000300	RING, 30	8							
24	1	129900-23000	ROD ASSY, CONNECTING	4							
28	2	129900-23910	BEARING, PISTON PIN	4							1
29	2	129900-23200	BOLT, CONNECTING ROD	8							
30	2	129900-23600	BEARING, CRANK PIN	4							
32	1	129900-23610	BEARING, 0.25 US	4							2
34	1	129902-22900	PISTON ASSY, 0.25 OS	4							3
36	2	129903-22950	RING SET, 0.25 OS	4							3
40	1	24341-000530	O-RING, 1AS53.0	1							

Remarks

- (1) REPAIR PART.
- (2) UNDER-SIZE(U.S=0.25)PART.
- (3) OVER-SIZE(O.S=0.25)PART.

Fig.9. LUB.OIL SYSTEM

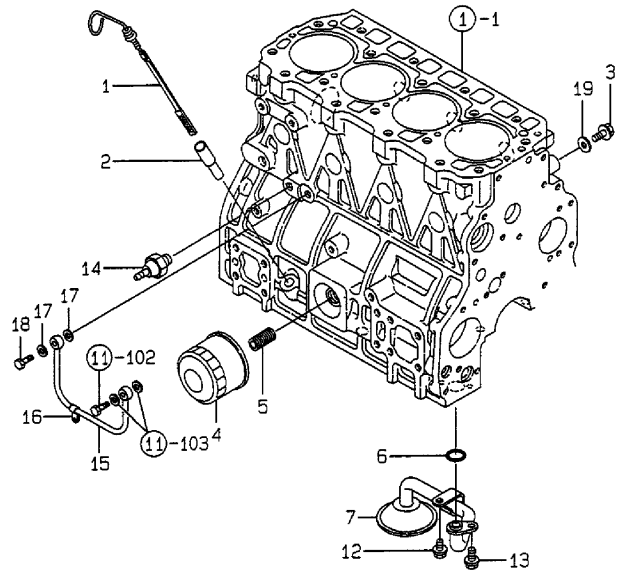

No.	Lev.	Parts No.	Description	Q'ty						I	R
				(A)	(B)	(C)	(D)	(E)	(F)		
1	1	129953-34800	DIPSTICK, OIL	1							
2	1	121520-34810	GUIDE, DIPSTICK	1							
3	1	26106-080122	BOLT, M8X 12 PLATED	1							
4	1	129150-35151	FILTER, D80XL80	1							
5	1	119000-35140	BOLT, FILTER	1							
6	1	129900-32030	O-RING, P20	1							
7	1	129900-35000	PIPE ASSY, OIL INLET	1							
12	1	26106-080122	BOLT, M8X 12 PLATED	1							
13	1	26106-080162	BOLT, M8X 16 PLATED	1							
14	1	124160-39450	SWITCH, 0.5KG	1							
15	1	129900-39350	PIPE, OIL	1							
16	1	23297-060081	CLAMP, A6X 8	1							
17	1	23414-080000	GASKET, 8X1.0	2							
18	1	23857-030000	BOLT, JOINT 3	1							
19	1	22190-080002	WASHER, SEAL 6	1							

Fig.10. COOLING WATER SYSTEM

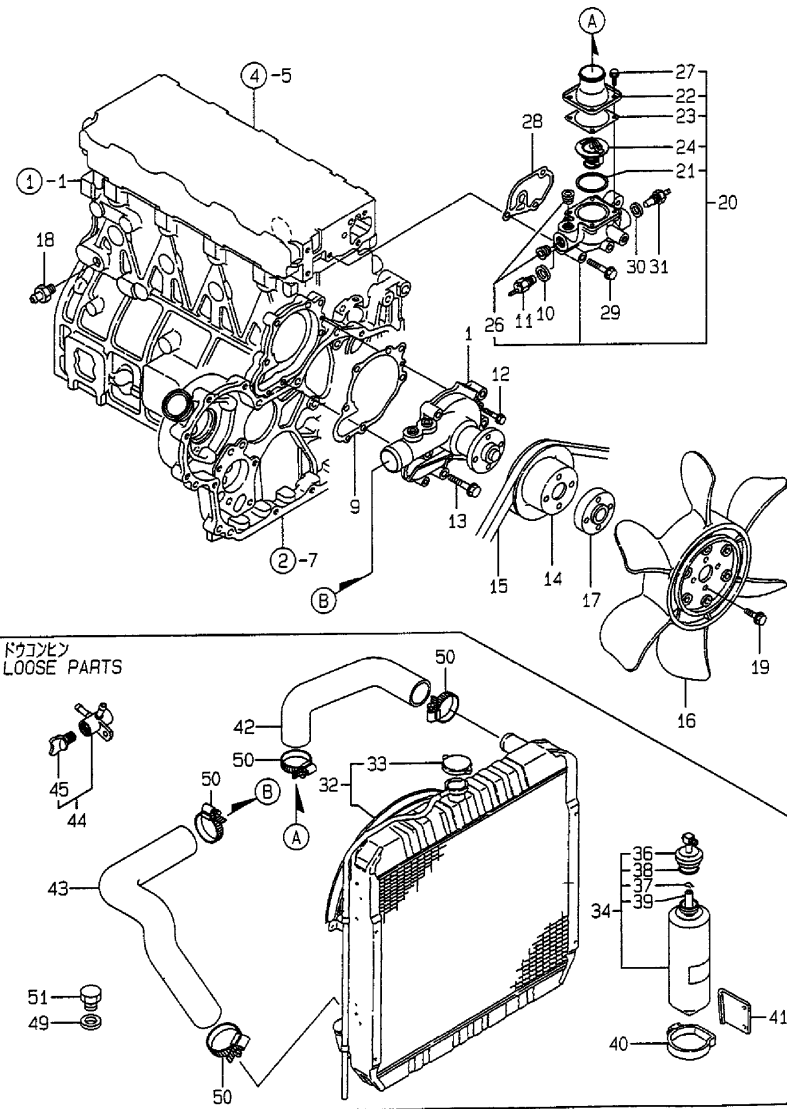

(A)=4TNE98-TB

(B)=

(C)=

(D)=

(E)=

(F)=

No.	Lev.	Parts No.	Description	Q'ty						I	R
				(A)	(B)	(C)	(D)	(E)	(F)		
1	1	129900-42001	PUMP ASSY, WATER	1							
9	1	129900-42020	GASKET, WATER PUMP	1							
10	1	124465-44950	GASKET, 16	1							
11	1	121250-44901	SWITCH, 110	1							
12	1	26106-060302	BOLT, M6X 30 PLATED	2							
13	1	26106-080552	BOLT, M8X 55 PLATED	5							
14	1	129900-42461	V-PULLEY	1							
15	1	25132-004200	V-BELT, A42	1							
16	1	129900-44700	FAN, COOLING D=410	1							
17	1	119130-44760	SPACER, FAN	1							
18	1	121550-49111	JOINT, PT1/4	1							
19	1	26014-080352	BOLT, M8X 35	4							
20	1	129900-49860	CASE ASSY, THERMOSTAT	1							
21	2	121850-49550	GASKET, THERMOSTAT	1							
22	2	121850-49530	COVER, THERMOSTAT	1							
23	2	121850-49540	GASKET, THERMOSTAT	1							
24	2	121850-49810	THERMOSTAT, 71	1							
26	2	23871-030000	PLUG, R03	2							
27	2	26106-060142	BOLT, M6X 14 PLATED	4							
28	1	129900-49870	GASKET	1							
29	1	26106-080602	BOLT, M8X 60 PLATED	3							
30	1	129150-49360	GASKET	1							
31	1	171056-49351	SENSOR	1							
32	1	171093-44500	RADIATOR	1							
33	2	119259-44570	CAP, RADIATOR	1							
34	1	171064-44510	TANK ASSY, SUB	1							
36	2	121450-44531	CAP	1							
37	2	124450-44560	RETAINER	1							
38	2	121470-44581	GASKET	1							
39	2	23065-070225	HOSE 7X 225	1							
40	1	124450-44550	BAND	1							
41	1	121256-44600	BRACKET, SUB TANK	1							
42	1	129915-49010	PIPE, WATER	1							
43	1	129911-49020	PIPE, WATER	1							
44	1	129150-49100	COCK ASSY, 3-WAY	1							
45	2	129150-49080	COCK, DRAIN	1							
49	1	22190-140000	WASHER, SEAL 14	1							
50	1	23000-054000	CLAMP, 54	4							
51	1	23887-140002	PLUG M14	1							

Fig.11. FUEL INJECTION PUMP

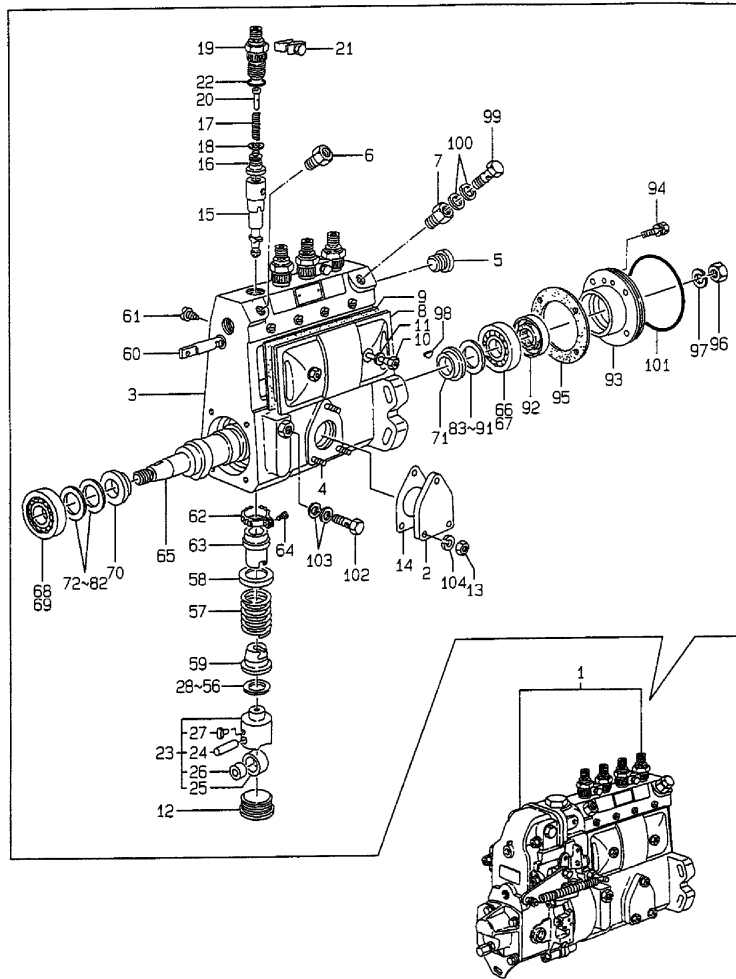

No.	Lev.	Parts No.	Description	Q'ty						I	R
				(A)	(B)	(C)	(D)	(E)	(F)		
1	1	129953-51000	PUMP ASSY, INJECTION	1							1
2	2	X1310400200	COVER	1							
3	2	X1310641621	FLANGED HOUSING	1							
4	2	X0290406020	STUD	3							
5	2	X1340260000	PLUG	1							
6	2	X1310022000	CAP	1							
7	2	X1310022000	CAP	1							
8	2	X1310286220	COVER	1							
9	2	X1310111900	GASKET	1							
10	2	X1310171000	SCREW	2							
11	2	X0293406020	GASKET	2							
12	2	X1310341401	PLUG	4							
13	2	X0130206040	NUT	3							
14	2	X1310410800	GASKET	1							
15	2	X1311523420	PLUNGER	4							
16	2	X1311607920	DELIVERY VALVE	4							
17	2	X1311123500	SPRING	4							
18	2	X1311151600	GASKET	4							
19	2	X1311167600	HOLDER	4							
20	2	X1311172300	STOPPER	4							
21	2	X1311220520	PLATE	2							
22	2	X0296320030	O-RING, 21X17X2	4							
23	2	X1312000220	TAPPET	4							
24	3	X1312030200	PIN	4							
25	3	X1312041000	ROLLER	4							
26	3	X1312050500	BUSH	4							
27	3	X1312060200	GUIDE	4							
28	2	X0293110020	SHIM	1							
29	2	X0293110030	SHIM	1							
30	2	X0293110040	SHIM	1							
31	2	X0293110050	SHIM	1							
32	2	X0293110060	SHIM	1							
33	2	X0293110070	SHIM	1							
34	2	X0293110080	SHIM	1							
35	2	X0293110090	SHIM	1							
36	2	X0293110110	SHIM	1							
37	2	X0293110120	SHIM	1							
38	2	X0293110130	SHIM	1							
39	2	X0293110140	SHIM	1							
40	2	X0293110270	SHIM	1							
41	2	X0293110280	SHIM	1							
42	2	X0293110290	SHIM	1							
43	2	X0293110310	SHIM	1							
44	2	X0293110320	SHIM	1							
45	2	X0293110330	SHIM	1							
46	2	X0293110340	SHIM	1							
47	2	X0293110350	SHIM	1							
48	2	X0293110490	SHIM	1							
49	2	X0293110500	SHIM	1							
50	2	X0293110580	SHIM	1							
51	2	X0293110590	SHIM	1							

Remarks

(1) GOVERNOR(FIG.NO.12) IS INCORPORATED IN THIS FUEL INJECTION PUMP (REF.NO.1).

Fig.11. FUEL INJECTION PUMP

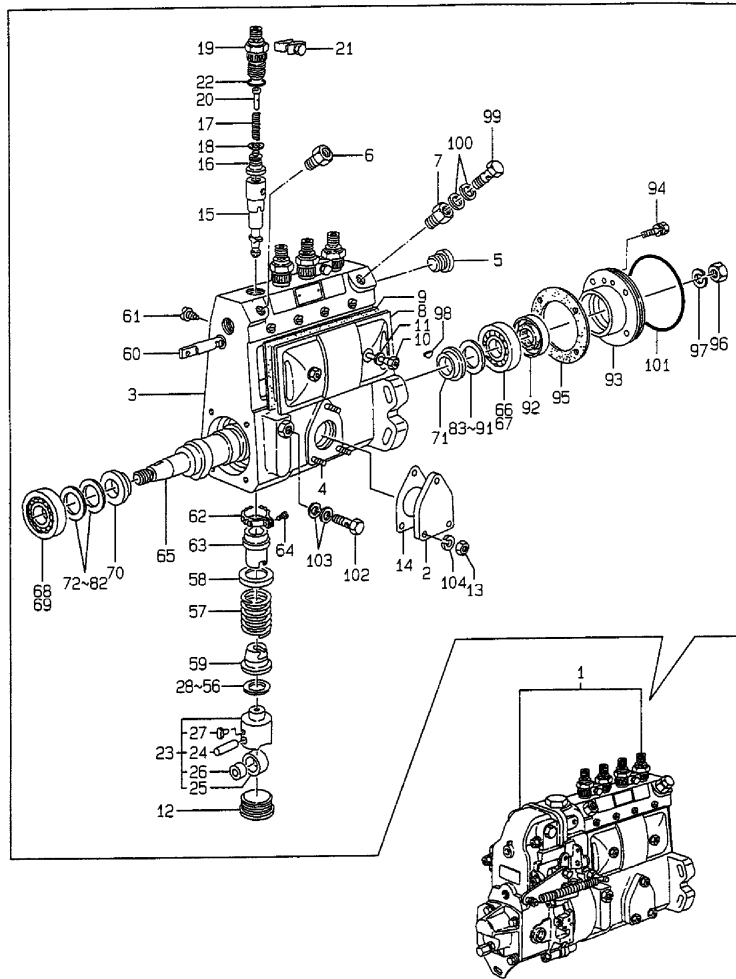

No.	Lev.	Parts No.	Description	Q'ty						I	R
				(A)	(B)	(C)	(D)	(E)	(F)		
52	2	X0293110600	SHIM	1							
53	2	X0293110610	SHIM	1							
54	2	X0293110620	SHIM	1							
55	2	X0293110630	SHIM	1							
56	2	X0293110710	SHIM	1							
57	2	X1312152500	SPRING	4							
58	2	X1312160100	SEAT, SPRING	4							
59	2	X1312170200	SEAT, SPRING	4							
60	2	X1312540600	RACK, CONTROL	1							
61	2	X1312260300	SCREW	1							
62	2	X1312400100	PINION	4							
63	2	X1312410100	SLEEVE, CONTROL	4							
64	2	X1312420100	SCREW	4							
65	2	X1313612700	CAMSHAFT	1							
66	2	X0166402030	BEARING	1							
67	2	X0282020020	BEARING	1							
68	2	X0166302030	BEARING	1							
69	2	X0282017020	BEARING	1							
70	2	X1313020300	RING	1							
71	2	X1313021000	RING	1							
72	2	X0293117010	SHIM	1							
73	2	X0293117020	SHIM	1							
74	2	X0293117030	SHIM	1							
75	2	X0293117040	SHIM	1							
76	2	X0293117050	SHIM	1							
77	2	X0293117060	SHIM	1							
78	2	X0293117070	SHIM	1							
79	2	X0293117090	SHIM	1							
80	2	X0293117210	SHIM	1							
81	2	X0293117220	SHIM	1							
82	2	X1394170000	SHIM	1							
83	2	X0293120220	SHIM	1							
84	2	X0293120230	SHIM	1							
85	2	X0293120240	SHIM	1							
86	2	X0293120250	SHIM	1							
87	2	X0293120260	SHIM	1							
88	2	X0293120270	SHIM	1							
89	2	X0293120290	SHIM	1							
90	2	X0293120300	SHIM	1							
91	2	X1394200400	SHIM	1							
92	2	X0296220190	SEAL, D30/20 T=6	1							
93	2	X1313301800	COVER	1							
94	2	X0200062040	BOLT	4							
95	2	X1313211900	GASKET	1							
96	2	X0131214140	NUT	1							
97	2	X0293214010	SPRING WASHER	1							
98	2	X0294704030	WOODRUFF KEY	1							
99	2	X0297314680	EYE BOLT	1							
100	2	X0265141840	GASKET	2							
101	2	X0296375020	O-RING	1							
102	2	X0297310120	EYE BOLT	1							

Remarks

(1) GOVERNOR(FIG.NO.12) IS INCORPORATED IN THIS FUEL INJECTION PUMP (REF.NO.1).

Fig.11. FUEL INJECTION PUMP

(A)=4TNE98-TB

(B)=

(C)=

(D)=

(E)=

(F)=

Q'ty

No.	Lev.	Parts No.	Description	(A)	(B)	(C)	(D)	(E)	(F)	I	R
103	2	X0265101340	GASKET	2							
104	2	X0141106440	SPRING WASHER	3							

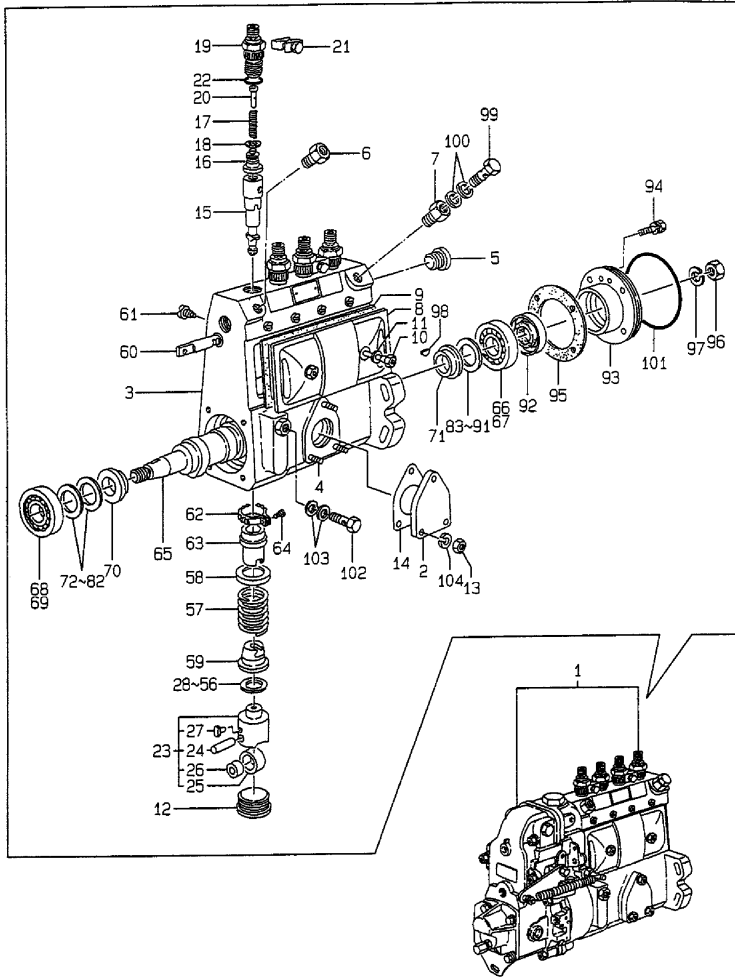

Remarks
 (1) GOVERNOR(FIG.NO.12) IS
 INCORPORATED IN THIS FUEL
 INJECTION PUMP (REF.NO.1).

Fig.12. GOVERNOR

(A)=4TNE98-TB

(B)=

(C)=

(D)=

(E)=

(F)=

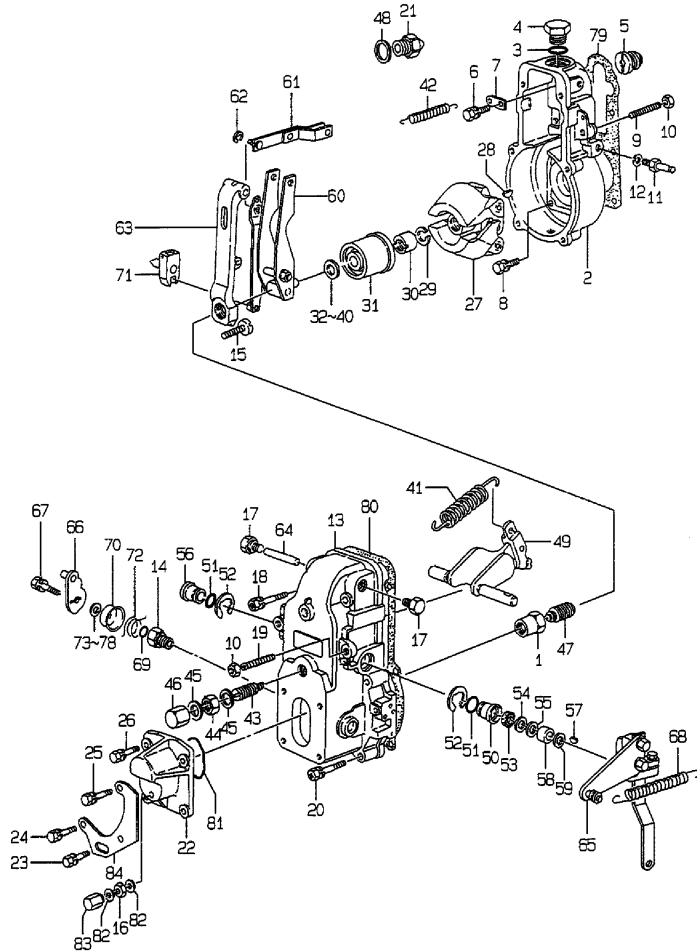

No.	Lev.	Parts No.	Description	Q'ty						I	R
				(A)	(B)	(C)	(D)	(E)	(F)		
1	2	X0292016010	NUT	1							
2	2	X1540006400	FLANGED HOUSING	1							
3	2	X0296325070	O-RING	1							
4	2	X1540072900	PLUG	1							
5	2	X1540070200	ADAPTOR	1							
6	2	X0200181840	BOLT	1							
7	2	X1543501900	PLATE	1							
8	2	X0290106810	BOLT	6							
9	2	X1540100100	SCREW	1							
10	2	X1540110100	NUT	2							
11	2	X1540132320	BOLT	1							
12	2	X0141108440	SPRING WASHER	1							
13	2	X1545001020	COVER	1							
14	2	X1543210400	BUSH	1							
15	2	X1540313000	SCREW	1							
16	2	X1392060600	NUT	1							
17	2	X1540360300	PLUG	2							
18	2	X0201065040	BOLT	2							
19	2	X1540100100	SCREW	1							
20	2	X0201063840	BOLT	4							
21	2	X1554045120	LIMITER	1							
22	2	X1540635100	COVER	1							
23	2	X0290206260	BOLT	1							
24	2	X0290206260	BOLT	1							
25	2	X0200062040	BOLT	1							
26	2	X0200061640	BOLT	1							
27	2	X1541010020	FLYWAIGHT ASSY.	1							
28	2	X0258031610	WOODRUFF KEY	1							
29	2	X0293212020	SPRING WASHER	1							
30	2	X0292312030	NUT	1							
31	2	X1541230120	SLEEVE	1							
32	2	X0293110010	SHIM T0.2 D14/10.1	1							
33	2	X0293110180	SHIM T0.3 D14/10.1	1							
34	2	X0293110190	SHIM T0.4 D14/10.1	1							
35	2	X0293110210	SHIM T1.0 D14/10.1	1							
36	2	X1394100000	SHIM T0.5 D14/10.1	1							
37	2	X1394100100	SHIM T1.5 D14/10.1	1							
38	2	X1394103000	SHIM T2.0 D14/10.1	1							
39	2	X1394103100	SHIM T3.0 D14/10.1	1							
40	2	X1394103200	SHIM T4.0 D14/10.1	1							
41	2	X1541502900	SPRING	1							
42	2	X1541540701	SPRING	1							
43	2	X1541581220	CAPSULE, SPRING	1							
44	2	X1540111700	NUT	1							
45	2	X0265121540	GASKET	2							
46	2	X1541591200	NUT, CAP	1							
47	2	X1541771220	SPRING	1							
48	2	X0265182240	GASKET	1							
49	2	X1542006920	LEVER	1							
50	2	X1542043000	BUSH	1							
51	2	X0296318020	O-RING	2							

Remarks

* THIS FIGURE(GOVERNOR ASSY)IS INCORPORATED IN THE FUEL INJECTION PUMP ASSY(FIG.11).

Fig.12. GOVERNOR

(A)=4TNE98-TB

(B)=

(C)=

(D)=

(E)=

(F)=

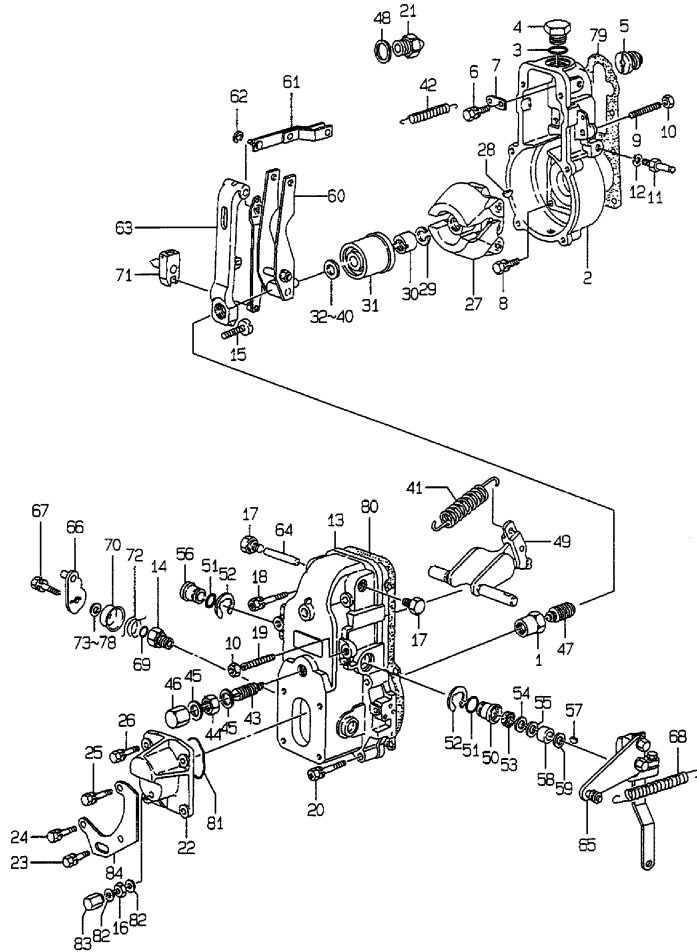

No.	Lev.	Parts No.	Description	Q'ty						I	R
				(A)	(B)	(C)	(D)	(E)	(F)		
52	2	X0160101640	RING, SNAP	2							
53	2	X1396110000	SEAL, OIL	1							
54	2	X1394110000	SHIM	1							
55	2	X0293111070	SHIM	1							
56	2	X1542043100	BUSH	1							
57	2	X0258031310	WOODRUFF KEY	1							
58	2	X1542062800	COLLAR	1							
59	2	X1542060200	WASHER	1							
60	2	X1542163820	LEVER ASSY, GUIDE	1							
61	2	X1542303920	LINK	1							
62	2	X0160100540	RING, SNAP	1							
63	2	X1542364100	LEVER, TENSION	1							
64	2	X1542370100	PIN	1							
65	2	X1543960320	LEVER	1							
66	2	X1543826020	LEVER	1							
67	2	X0200061640	BOLT	1							
68	2	X1543142600	SPRING	1							
69	2	X0296310030	O-RING	1							
70	2	X1543220100	CAP	1							
71	2	X1543265020	LEVER ASSY	1							
72	2	X1543277600	SPRING	1							
73	2	X0293110520	SHIM	1							
74	2	X0293110530	SHIM	1							
75	2	X0293110540	SHIM	1							
76	2	X0293110550	SHIM	1							
77	2	X0293110560	SHIM	1							
78	2	X0293110570	SHIM	1							
79	2	X1543507700	GASKET	1							
80	2	X1543507800	GASKET	1							
81	2	X0296352020	O-RING	1							
82	2	X0265061040	GASKET	2							
83	2	X1540351600	CAP NUT	1							
84	2	X1543587200	BRACKET	1							

Remarks

* THIS FIGURE(GOVERNOR ASSY)IS INCORPORATED IN THE FUEL INJECTION PUMP ASSY(FIG.11).

Fig.13. FUEL INJECTION VALVE

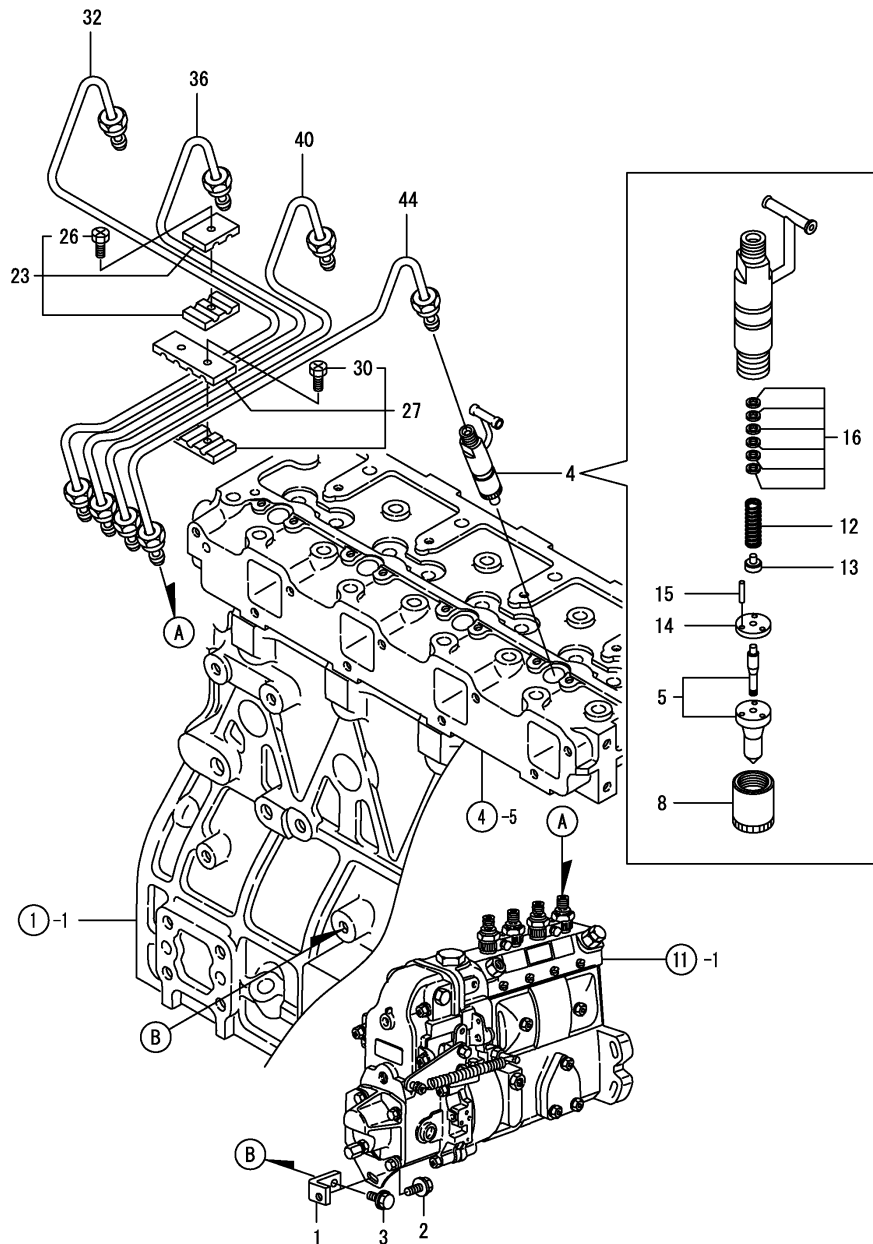

(A)=4TNE98-TB

(B)=

(C)=

(D)=

(E)=

(F)=

No.	Lev.	Parts No.	Description	Q'ty						I	R
				(A)	(B)	(C)	(D)	(E)	(F)		
1	1	129900-01950	RETAINER	1							
2	1	26106-100142	BOLT, M10X 14 PLATED	1							
3	1	26106-080202	BOLT, M8X 20 PLATED	1							
4	1	729902-53100	VALVE ASSY,INJECTION	4							
5	2	129902-53000	VALVE ASSY,INJECTION	4							
8	2	114250-53080	NUT, NOZZLE D16.95	4							
12	2	114250-53120	SPRING, NOZZLE	4							
13	2	114250-53130	SEAT, SPRING	4							
14	2	114250-53140	PLATE	4							
15	2	114250-53210	PIN	8							
16	2	114250-53400	SHIM SET	4							
23	1	119305-59120	RETAINER, PIPE	2							
26	2	129150-59131	BOLT, M4X14	2							
27	1	129550-59120	RETAINER, PIPE	1							
30	2	129150-59131	BOLT, M4X14	2							
32	1	129902-59810	PIPE ASSY, INJECTION	1							
36	1	129902-59820	PIPE ASSY, INJECTION	1							
40	1	129902-59830	PIPE ASSY, INJECTION	1							
44	1	129902-59840	PIPE ASSY, INJECTION	1							

Fig.14. FUEL LINE

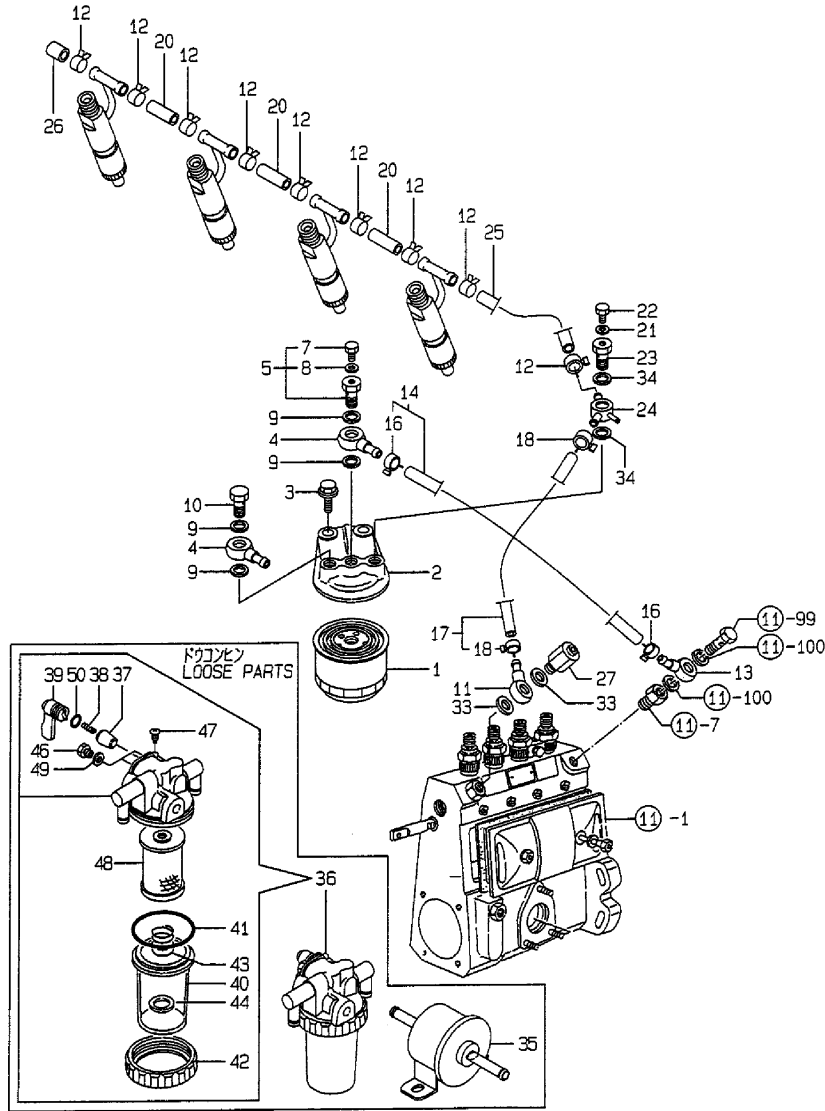

(A)=4TNE98-TB

(B)=

(C)=

(D)=

(E)=

(F)=

No.	Lev.	Parts No.	Description	Qty						I	R
				(A)	(B)	(C)	(D)	(E)	(F)		
1	1	119000-55600	FILTER, FUEL	1							
2	1	129470-55610	BODY, STRAINER	1							
3	1	26106-100252	BOLT, M10X 25 PLATED	2							
4	1	101304-59020	JOINT, PIPE 12	2							
5	1	103854-59191	BOLT ASSY, JOINT M12	1							
7	2	124060-59380	PLUG, 6	1							
8	2	22190-060002	WASHER, SEAL 6	1							
9	1	22190-120002	WASHER, SEAL 12	4							
10	1	23857-060000	BOLT, JOINT 6	1							
11	1	121855-59880	JOINT, PIPE	1							
12	1	124066-59100	CLIP, HOSE 8	9							
13	1	121855-59880	JOINT, PIPE	1							
14	1	129210-59170	PIPE ASSY, FUEL	1							
16	2	124766-59050	CLIP, HOSE 12	2							
17	1	129210-59110	PIPE ASSY, FUEL	1							
18	2	124766-59050	CLIP, HOSE 12	2							
20	1	121250-59550	PIPE, FUEL D8X120	3							
21	1	23414-080000	GASKET, 8X1.0	1							
22	1	26106-080102	BOLT, M8X 10 PLATED	1							
23	1	129495-59300	BOLT, PIPE JOINT	1							
24	1	129470-59530	JOINT, PIPE	1							
25	1	105225-59120	PIPE, FUEL RETURN	1							
26	1	129150-59580	CAP	1							
27	1	128300-59910	VALVE ASSY, OVERFLOW	1							
33	1	22190-140002	WASHER, SEAL 14	2							
34	1	22190-140002	WASHER, SEAL 14	2							
35	1	119225-52102	PUMP ASSY, FUEL FEED	1							
36	1	129335-55700	SEPARATOR ASSY,WATER	1							
37	2	104200-55321	VALVE, TAPER	1							
38	2	104200-55330	SPRING, VALVE	1							
39	2	104200-55341	HANDLE	1							
40	2	124064-55510	COVER	1							
41	2	102103-55520	O-RING	1							
42	2	110250-55610	RING, RETAINING	1							
43	2	121257-55720	SPRING	1							
44	2	121257-55731	FLOAT	1							
46	2	101720-55750	PLUG, 6	2							
47	2	104200-55750	SCREW, M4	1							
48	2	171081-55910	SCREEN	1							
49	2	23418-060000	GASKET, 6X1.0	2							
50	2	24311-240100	O-RING, 1AP10A	1							

Fig.15. ENGINE STOP DEVICE

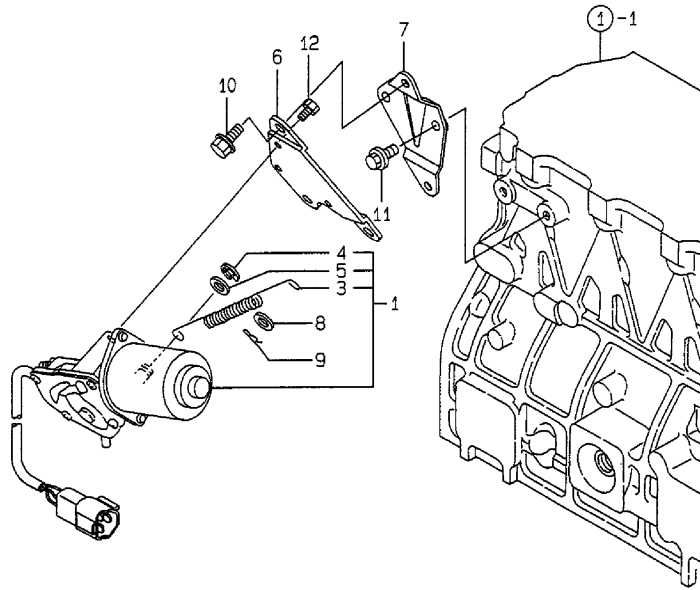

(A)=4TNE98-TB
(B)=
(C)=

(D)=
(E)=
(F)=

No.	Lev.	Parts No.	Description	Q'ty						I	R
				(A)	(B)	(C)	(D)	(E)	(F)		
1	1	129900-66790	MOTOR ASSY, STOP	1							
3	2	129900-66830	SPRING, STOP MOTOR	1							
4	2	129566-66880	RING, SNAP	1							
5	2	129566-66890	WASHER	1							
6	1	119840-66811	BRACKET, STOP MOTOR	1							
7	1	129900-66820	BRACKET, STOP MOTOR	1							
8	1	22117-080000	WASHER, 8	1							
9	1	22360-080000	SNAP PIN 8	1							
10	1	26106-080122	BOLT, M8X 12 PLATED	2							
11	1	26106-080122	BOLT, M8X 12 PLATED	2							
12	1	26116-050102	BOLT, M5X 10 PLATED	3							

Fig.16. STARTING MOTOR

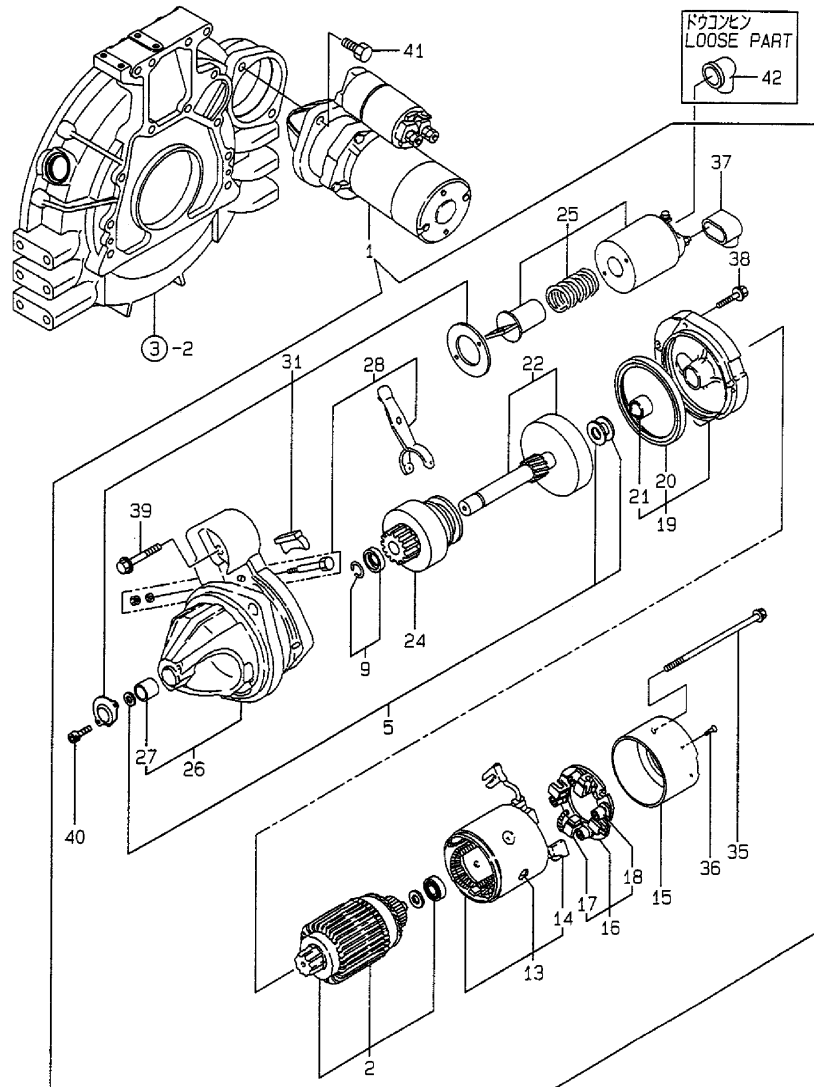

(A)=4TNE98-TB

(B)=

(C)=

(D)=

(E)=

(F)=

No.	Lev.	Parts No.	Description	Qty						I	R
				(A)	(B)	(C)	(D)	(E)	(F)		
1	1	129953-77010	STARTING MOTOR	1							
2	2	121254-77402	ARMATURE ASSY	1							
5	2	121254-77430	WASHER KIT, THRUST	1							
9	2	121254-77480	STOPPER KIT, PINION	1							
13	3	121254-77521	COIL ASSY, FIELD	1							
14	4	121254-77541	BRUSH (+)	2							
15	2	121254-77550	COVER ASSY, REAR	1							
16	2	121254-77571	HOLDER ASSY	1							
17	3	121254-77581	BRUSH, -	2							
18	3	121254-77590	SPRING, BRUSH	4							
19	2	121254-77600	BEARING ASSY, CENTER	1							
20	3	121254-77610	SEAL, OIL	1							
21	3	121254-77620	BEARING, NEEDLE	1							
22	2	121254-77640	SHAFT ASSY, GEAR	1							
24	2	129953-77660	PINION ASSY	1							
25	2	X2130670040	SWITCH, MAGNETIC	1							
26	2	121254-77681	CASE ASSY, GEAR	1							
27	3	121254-77690	METAL, GEAR CASE	1							
28	2	121254-77700	LEVER SET, SHIFT	1							
31	2	121254-77730	DUST COVER SET	1							
35	2	121254-77770	BOLT, THROUGH	2							
36	2	121254-77790	SCREW 4	2							
37	2	121254-77810	COVER, TERMINAL	1							
38	2	26106-060302	BOLT, M6X 30 PLATED	3							
39	2	26106-060452	BOLT, M6X 45 PLATED	2							
40	2	121254-77780	SCREW 5	2							
41	1	26116-120302	BOLT, M12X 30 PLATED	2							
42	1	124550-77030	COVER, TERMINAL	1							

Fig.17. GENERATOR

(A)=4TNE98-TB
(B)=
(C)=

(D)=
(E)=
(F)=

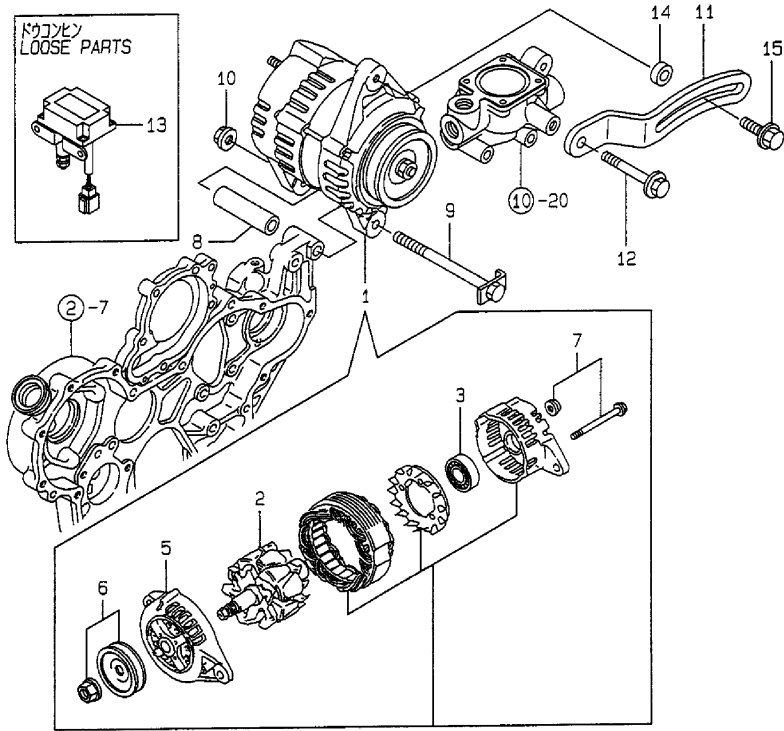
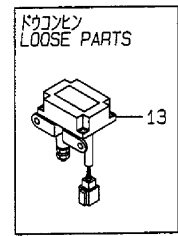

No.	Lev.	Parts No.	Description	Q'ty						I	R
				(A)	(B)	(C)	(D)	(E)	(F)		
1	1	119836-77201	GENERATOR (AC)	1							
2	2	129612-77700	ROTOR ASSY	1							
3	2	129612-77710	BEARING, BALL	1							
5	2	129612-77730	BRACKET ASSY, FILTER	1							
6	2	129612-77740	PULLEY	1							
7	2	129612-77750	SCREW KIT	1							
8	1	129150-77340	SPACER	1							
9	1	129953-77201	BOLT	1							
10	1	129612-77260	NUT, ALTERNATOR	1							
11	1	129953-77330	ADJUSTER	1							
12	1	26014-080252	BOLT, M8X 25	1							
13	1	129136-77100	RELAY, SAFETY	1							
14	1	106500-44810	SPACER	1							
15	1	119810-77340	BOLT, ADJUSTER	1							

Fig.18. GASKET SET

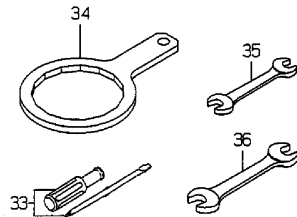
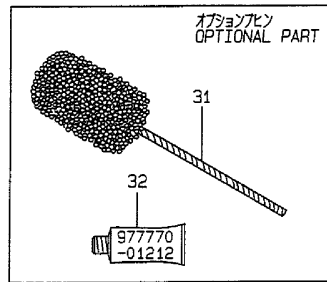
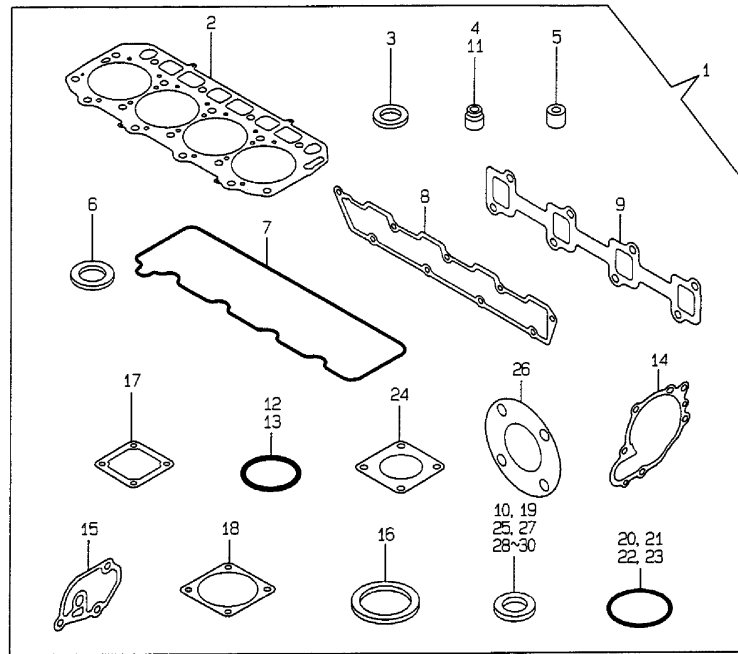

(A)=4TNE98-TB

(B)=

(C)=

(D)=

(E)=

(F)=

No.	Lev.	Parts No.	Description	Q'ty						I	R
				(A)	(B)	(C)	(D)	(E)	(F)		
1	1	729902-92660	GASKET SET	1							1
2	2	129902-01330	GASKET, HEAD	1							
3	2	22190-220002	WASHER, SEAL 22	1							
4	2	124460-11340	SEAL, VALVE STEM	4							
5	2	119625-11870	PROTECTOR, NOZZLE	4							
6	2	119625-11880	SEAT, NOZZLE	4							
7	2	129900-11310	GASKET, BONNET	1							
8	2	129900-12050	GASKET, MANIFOLD	1							
9	2	129900-13251	GASKET	1							
10	2	23414-080000	GASKET, 8X1.0	2							
11	2	121400-11340	SEAL, VALVE STEM	4							
12	2	129900-32030	O-RING, P20	2							
13	2	129900-32040	O-RING, P14	1							
14	2	129900-42020	GASKET, WATER PUMP	1							
15	2	129900-49870	GASKET	1							
16	2	121850-49550	GASKET, THERMOSTAT	1							
17	2	121850-77021	GASKET	1							
18	2	121850-49540	GASKET, THERMOSTAT	1							
19	2	124465-44950	GASKET, 16	2							
20	2	24311-000070	O-RING, 1AP7.0	1							
21	2	24311-000120	O-RING, 1AP12.0	3							
22	2	24341-000240	O-RING, 1AS24.0	1							
23	2	24311-000320	O-RING, 1AP32.0	3							
24	2	129400-13201	GASKET, SILENCER	2							
25	2	22190-080002	WASHER, SEAL 6	1							
26	2	23446-050000	GASKET 50	1							
27	2	129150-49360	GASKET	1							
28	2	22190-060002	WASHER, SEAL 6	1							
29	2	22190-120002	WASHER, SEAL 12	4							
30	2	22190-140002	WASHER, SEAL 14	2							
31	1	129400-92440	HONE	1							1
32	1	977770-01212	GASKET, LIQUID	1							1
33	1	104200-92350	DRIVER, SCREW	1							
34	1	119640-92750	WRENCH, FILTER 80	1							
35	1	28110-100120	SPANNER, 10X12	1							
36	1	28110-140170	SPANNER, 14X17	1							

Remarks

(1) OPTIONAL PART.

Parts No. Index

Parts No.	Fig. No.	Ref. No.
101304-59020	14	4
101720-55750	14	46
102103-55520	14	41
103854-59191	14	5
104200-55321	14	37
104200-55330	14	38
104200-55341	14	39
104200-55750	14	47
104200-92350	18	33
105225-59120	14	25
106500-44810	17	14
110250-55610	14	42
114250-53080	13	8
114250-53120	13	12
114250-53130	13	13
114250-53140	13	14
114250-53210	13	15
114250-53400	13	16
119000-35140	9	5
119000-55600	14	1
119005-12080	5	9
119100-11330	4	52
119129-13500	6	10
119130-44760	10	17
119131-18320	6	9
119140-12680	5	16
119160-12060	5	8
119225-52102	14	35
119259-44570	10	33
119305-59120	13	23
119625-11870	4	20
	18	5
119625-11880	4	21
	18	6
119625-11900	4	22
119640-01640	3	9
119640-92750	18	34
119808-12540	5	15
119810-77340	17	15
119836-77201	17	1
119840-66811	15	6
120130-22301	8	22
121023-01550	2	17
121250-44901	10	11
121250-59550	14	20
121254-77402	16	2
121254-77430	16	5
121254-77480	16	9
121254-77521	16	13
121254-77541	16	14

Parts No.	Fig. No.	Ref. No.
121254-77550	16	15
121254-77571	16	16
121254-77581	16	17
121254-77590	16	18
121254-77600	16	19
121254-77610	16	20
121254-77620	16	21
121254-77640	16	22
121254-77681	16	26
121254-77690	16	27
121254-77700	16	28
121254-77730	16	31
121254-77770	16	35
121254-77780	16	40
121254-77790	16	36
121254-77810	16	37
121256-44600	10	41
121257-55720	14	43
121257-55731	14	44
121400-11340	4	17
	18	11
121450-44531	10	36
121470-44581	10	38
121520-34810	9	2
121550-49111	10	18
121850-21130	8	11
121850-21290	8	5
121850-21680	8	10
121850-21920	8	6
121850-49530	10	22
121850-49540	10	23
	18	18
121850-49550	10	21
	18	16
121850-49810	10	24
121850-77021	5	5
	18	17
121855-59880	14	11
		13
124060-59380	14	7
124064-55510	14	40
124066-59100	14	12
124160-01751	2	28
	4	58
124160-11360	4	45
124160-39450	9	14
124411-01780	3	7
124450-44550	10	40
124450-44560	10	37
124460-11340	4	18

Parts No.	Fig. No.	Ref. No.
124460-11340	18	4
124465-44950	10	10
	18	19
124550-77030	16	42
124766-59050	14	16
		18
128300-59910	14	27
129001-91810	2	26
		27
129062-12560	5	13
129100-01580	2	14
	3	1
129136-77100	17	13
129150-02450	7	4
129150-11230	4	34
		38
129150-11370	4	19
129150-11750	4	36
		40
129150-11810	4	9
129150-14200	7	1
129150-25920	7	14
129150-35151	9	4
129150-49080	10	45
129150-49100	10	44
129150-49360	10	30
	18	27
129150-59131	13	26
		30
129150-59580	14	26
129150-77340	17	8
129210-59110	14	17
129210-59170	14	14
129335-55700	14	36
129400-13201	6	7
	18	24
129400-92440	18	31
129457-12530	5	14
129470-55610	14	2
129470-59530	14	24
129495-59300	14	23
129550-59120	13	27
129566-66880	15	4
129566-66890	15	5
129612-77260	17	10
129612-77700	17	2
129612-77710	17	3
129612-77730	17	5
129612-77740	17	6
129612-77750	17	7

Parts No.	Fig. No.	Ref. No.
129795-11180	4	16
129900-01200	1	28
129900-01780	2	4
129900-01820	2	7
129900-01950	13	1
129900-02020	1	7
129900-02340	1	30
129900-02410	1	10
129900-02800	1	16
129900-02930	1	25
129900-02940	1	33
129900-11100	4	13
129900-11110	4	14
129900-11120	4	15
129900-11200	4	26
129900-11240	4	27
129900-11280	4	30
129900-11310	4	47
	18	7
129900-11350	4	46
129900-11510	4	31
129900-11520	4	32
129900-11530	4	43
129900-11600	4	50
129900-11650	4	33
129900-11660	4	37
129900-12050	5	1
	18	8
129900-12100	5	2
129900-13200	6	1
129900-13251	6	3
	18	9
129900-14100	7	7
129900-14400	7	2
129900-14580	7	3
129900-21200	8	4
129900-21600	8	15
129900-23000	8	24
129900-23200	8	29
129900-23600	8	30
129900-23610	8	32
129900-23910	8	28
129900-25060	7	10
129900-25100	7	11
129900-25900	7	16
129900-32000	2	10
129900-32030	2	12
	9	6
	18	12
129900-32040	2	13

Parts No. Index

Parts No.	Fig. No.	Ref. No.
129900-32040	18	13
129900-35000	9	7
129900-39350	9	15
129900-42001	10	1
129900-42020	10	9
	18	14
129900-42461	10	14
129900-44700	10	16
129900-49860	10	20
129900-49870	10	28
	18	15
129900-66790	15	1
129900-66820	15	7
129900-66830	15	3
129902-01330	1	29
	18	2
129902-21000	8	1
129902-22080	8	16
129902-22900	8	34
129902-53000	13	5
129902-59810	13	32
129902-59820	13	36
129902-59830	13	40
129902-59840	13	44
129903-22050	8	18
129903-22950	8	36
129910-03100	4	60
129910-07900	4	4
129911-49020	10	43
129915-49010	10	42
129915-77050	5	6
129951-01740	2	5
129953-01620	3	2
129953-01710	3	8
129953-03100	4	1
129953-07910	4	59
129953-12200	5	10
129953-12520	5	11
129953-12540	5	17
129953-12560	5	12
129953-21581	8	12
129953-21610	8	8
129953-21611	8	8 -1
129953-34800	9	1
129953-51000	11	1
129953-77010	16	1
129953-77201	17	9
129953-77330	17	11
129953-77660	16	24
129960-03990	4	3

Parts No.	Fig. No.	Ref. No.
129960-21640	8	9
171031-11741	2	16
171051-01921	1	6
171056-49351	10	31
171064-44510	10	34
171081-55910	14	48
171093-44500	10	32
22117-080000	15	8
22190-060002	14	8
	18	28
22190-080002	9	19
	18	25
22190-120002	14	9
	18	29
22190-140000	10	49
22190-140002	14	33
		34
	18	30
22190-220002	3	12
	18	3
22242-000180	4	41
22252-000300	8	23
22351-060012	1	11
22360-080000	15	9
22512-070140	7	8
	8	7
22857-500100	4	51
23000-054000	10	50
23000-080000	5	18
23065-070225	10	39
23297-060081	9	16
23414-080000	9	17
	14	21
	18	10
23418-060000	14	49
23446-050000	6	8
	18	26
23857-030000	9	18
23857-060000	14	10
23871-005000	4	11
23871-030000	1	5
		12
		14
	10	26
23887-140002	10	51
24311-000070	2	29
	18	20
24311-000120	4	53
	18	21
24311-000320	2	30

Parts No.	Fig. No.	Ref. No.
24311-000320	2	31
	4	57
	18	23
24311-240100	14	50
24341-000240	2	18
	18	22
24341-000530	8	40
25132-004200	10	15
26014-080252	17	12
26014-080352	10	19
26106-060142	10	27
26106-060162	2	19
26106-060302	10	12
	16	38
26106-060452	16	39
26106-080102	14	22
26106-080122	3	13
	4	61
	9	3
		12
	15	10
		11
26106-080162	2	20
	4	54
	7	9
	9	13
26106-080202	2	21
	5	19
	13	3
26106-080302	2	22
26106-080352	5	7
26106-080402	2	23
		24
26106-080452	2	25
	5	4
26106-080552	7	15
	10	13
26106-080602	10	29
26106-080802	6	4
26106-100142	13	2
26106-100252	14	3
26106-100352	3	5
26106-100652	4	55
26116-050102	15	12
26116-120302	16	41
26206-100702	3	6
26216-060202	4	23
26216-080802	6	5
26216-100302	2	11
26366-060002	4	24

Parts No.	Fig. No.	Ref. No.
26366-080002	6	6
26366-100002	2	15
	4	44
26577-040162	4	42
27231-550000	1	13
27241-300000	1	15
27241-400000	4	12
27310-080001	4	25
28110-100120	18	35
28110-140170	18	36
729900-01570	2	1
729900-11100	4	5
729902-01560	1	1
729902-53100	13	4
729902-92660	18	1
977770-01212	2	6
	3	14
	4	56
	18	32
X0130206040	11	13
X0131214140	11	96
X0141106440	11	104
X0141108440	12	12
X0160100540	12	62
X0160101640	12	52
X0166302030	11	68
X0166402030	11	66
X0200061640	12	26
		67
X0200062040	11	94
	12	25
X0200181840	12	6
X0201063840	12	20
X0201065040	12	18
X0258031310	12	57
X0258031610	12	28
X0265061040	12	82
X0265101340	11	103
X0265121540	12	45
X0265141840	11	100
X0265182240	12	48
X0282017020	11	69
X0282020020	11	67
X0290106810	12	8
X0290206260	12	23
		24
X0290406020	11	4
X0292016010	12	1
X0292312030	12	30
X0293110010	12	32

Parts No. Index

Parts No.	Fig. No.	Ref. No.
X0293110020	11	28
X0293110030	11	29
X0293110040	11	30
X0293110050	11	31
X0293110060	11	32
X0293110070	11	33
X0293110080	11	34
X0293110090	11	35
X0293110110	11	36
X0293110120	11	37
X0293110130	11	38
X0293110140	11	39
X0293110180	12	33
X0293110190	12	34
X0293110210	12	35
X0293110270	11	40
X0293110280	11	41
X0293110290	11	42
X0293110310	11	43
X0293110320	11	44
X0293110330	11	45
X0293110340	11	46
X0293110350	11	47
X0293110490	11	48
X0293110500	11	49
X0293110520	12	73
X0293110530	12	74
X0293110540	12	75
X0293110550	12	76
X0293110560	12	77
X0293110570	12	78
X0293110580	11	50
X0293110590	11	51
X0293110600	11	52
X0293110610	11	53
X0293110620	11	54
X0293110630	11	55
X0293110710	11	56
X0293110700	12	55
X0293117010	11	72
X0293117020	11	73
X0293117030	11	74
X0293117040	11	75
X0293117050	11	76
X0293117060	11	77
X0293117070	11	78
X0293117090	11	79
X0293117210	11	80
X0293117220	11	81
X0293120220	11	83

Parts No.	Fig. No.	Ref. No.
X0293120230	11	84
X0293120240	11	85
X0293120250	11	86
X0293120260	11	87
X0293120270	11	88
X0293120290	11	89
X0293120300	11	90
X0293212020	12	29
X0293214010	11	97
X0293406020	11	11
X0294704030	11	98
X0296220190	11	92
X0296310030	12	69
X0296318020	12	51
X0296320030	11	22
X0296325070	12	3
X0296352020	12	81
X0296375020	11	101
X0297310120	11	102
X0297314680	11	99
X1310022000	11	6
		7
X1310111900	11	9
X1310171000	11	10
X1310286220	11	8
X1310341401	11	12
X1310400200	11	2
X1310410800	11	14
X1310641621	11	3
X1311123500	11	17
X1311151600	11	18
X1311167600	11	19
X1311172300	11	20
X1311220520	11	21
X1311523420	11	15
X1311607920	11	16
X1312000220	11	23
X1312030200	11	24
X1312041000	11	25
X1312050500	11	26
X1312060200	11	27
X1312152500	11	57
X1312160100	11	58
X1312170200	11	59
X1312260300	11	61
X1312400100	11	62
X1312410100	11	63
X1312420100	11	64
X1312540600	11	60
X1313020300	11	70

Parts No.	Fig. No.	Ref. No.
X1313021000	11	71
X1313211900	11	95
X1313301800	11	93
X1313612700	11	65
X1340260000	11	5
X1392060600	12	16
X1394100000	12	36
X1394100100	12	37
X1394103000	12	38
X1394103100	12	39
X1394103200	12	40
X1394110000	12	54
X1394170000	11	82
X1394200400	11	91
X1396110000	12	53
X1540006400	12	2
X1540070200	12	5
X1540072900	12	4
X1540100100	12	9
		19
X1540110100	12	10
X1540111700	12	44
X1540132320	12	11
X1540313000	12	15
X1540351600	12	83
X1540360300	12	17
X1540635100	12	22
X1541010020	12	27
X1541230120	12	31
X1541502900	12	41
X1541540701	12	42
X1541581220	12	43
X1541591200	12	46
X1541771220	12	47
X1542006920	12	49
X1542043000	12	50
X1542043100	12	56
X1542060200	12	59
X1542062800	12	58
X1542163820	12	60
X1542303920	12	61
X1542364100	12	63
X1542370100	12	64
X1543142600	12	68
X1543210400	12	14
X1543220100	12	70
X1543265020	12	71
X1543277600	12	72
X1543501900	12	7
X1543507700	12	79

Parts No.	Fig. No.	Ref. No.
X1543507800	12	80
X1543587200	12	84
X1543826020	12	66
X1543960320	12	65
X1545001020	12	13
X1554045120	12	21
X2130670040	16	25