

OCD10-M64100EN

PREFACE

1. This Parts Catalog is the 1st edition of 4TNE84-P Diesel Engine for TERAL KYOKUTO.

Pub. No. : 000Y00D6410
Published : November, 1997

2. Model name

Engine model	Vehicle		Vehicle made by
	Products	Model name	
4TNE84-P	FIRE PUMP SMOKE EXTRACTION MACHINE	—	TERAL KYOKUTO

Directions for the Parts Catalog.

1. This Parts Catalog shows both standard and optional parts.
2. Parts may change without prior notice.
3. The following is an example of the Parts Catalog format.

REF.	LEV.	PARTS NO.	DESCRIPTION	Q'TY						I	R
				(A)	(B)	(C)	(D)	(E)	(F)		
1	1	729595-51390	FUEL INJECTION PUMP	1	1	1	1	1			1
1-1	1	729595-51391	FUEL INJECTION PUMP	1	1	1	1	1		N	1
		(A=E00185) (B=E00200)									
3	2	26022-060162	SCREW M 6X 16	9	9	9	9	9			
3-1	2	26022-060162	SCREW M 6X 16	4	4	4	4	4		K	
		(A=E00156) (B=E00156) (C=E00156) (D=E00156) (E=E00156)									
4	2	129470-51040	CAMSHAFT	1	1	1	1	1			
5	2	122710-51050	BEARING, ROLLER	2	2	2	2	2			
6	2	129470-51060	RETAINER	1	1	1	1	1			

Remarks
(1) BOOST COMPEMSATOR TYPE. OPTIONAL PART, TO E00155,(4JH-DT, 4JH-DTZ

① Ref. No.

The Ref. No. listed may not be in accordance with the illustration Ref. No.

(Ex.) Illustration No.

List Ref No.

1

1

(Before change)

1-1

(After change)

For interchangeable symbols N, R and K, illustrations for new parts may be abbreviated.

② Lev. (Level)

Level indication

The numbers below indicate the level of relativity towards the main part.

1 ----- Main parts (Assembly parts)

2 ----- Sub component included in " 1 ".

3 ----- Sub component included in " 2 ".

Note) Parts that are not for sale are partially illustrated but not listed.

③ Interchangeability Symbol

When a part change takes place, one of the following interchangeability symbols is indicated beside the part.

Symbol	Interchangeability	Contents note
N	Old $\begin{matrix} \leftarrow \text{Yes} \\ \text{No} \rightarrow \end{matrix}$ New	New Part is interchangeable for Old Part but Old Part is not interchangeable for New Part.
Q	Old $\begin{matrix} \leftarrow \text{No} \\ \text{Yes} \rightarrow \end{matrix}$ New	New Part is not interchangeable for Old Part but Old Part is interchangeable for New Part.
R	Old $\begin{matrix} \leftarrow \text{Yes} \\ \text{Yes} \rightarrow \end{matrix}$ New	New/ Old Parts are both interchangeable.
S	Old $\begin{matrix} \leftarrow \text{No} \\ \text{No} \rightarrow \end{matrix}$ New	New/ Old Parts are both not interchangeable.
W		Part newly added.
Z		Part discontinued.
F		Not interchangeable by a single part but interchangeable together with related parts.
K		Changes only for used parts quantities.

④ Effective Machine No.

When a part changes, the effective Machine No. will be indicated in the (A)-(F) column.

Product Symbol	Product No.	Product Symbol	Product No.
C	Clutch No. Compressor No.	F	Machine No. (Agricultural Equip.)
D	Drive No.	M	Machine No.
E	Engine No.		

Note 1) A date may follow the symbol. (Ex.) 1996.01

Note 2) "XXXXX" and "ZZZZZ" are for parts that could not be predicted or for engine models that could not be identified.

Note 3) (A=E00185) is the E (Engine Serial Number) for the column (A) model (in this case 4JH-DT) after the parts design change.

⑤ Remarks

Figures or alphabets (symbols) are entered in the remarks column.

The comments (remarks) on parts that are indicated at the bottom of the illustration are the same symbols as those stated above.

Contents

OCD10-M64100

Fig. No.	Fig. Name	Fig. No.	Fig. Name
4TNE84-P			
1.	CYLINDER BLOCK		
2.	GEAR HOUSING		
3.	FLYWHEEL HOUSING & OIL SUMP		
4.	CYLINDER HEAD & BONNET		
5.	SUCTION MANIFOLD & AIR CLEANER		
6.	EXHAUST MANIFOLD & SILENCER		
7.	CAMSHAFT & DRIVING GEAR		
8.	CRANKSHAFT & PISTON		
9.	LUB.OIL SYSTEM		
10.	COOLING WATER SYSTEM		
11.	FUEL INJECTION PUMP		
12.	GOVERNOR		
13.	FUEL INJECTION VALVE		
14.	FUEL OIL TANK		
15.	FUEL LINE		
16.	ENGINE STOP SOLENOID		
17.	CONTROL DEVICE		
18.	STARTING MOTOR		
19.	GENERATOR		
20.	CLUTCH		
21.	INSTRUMENT PANEL		
22.	SAFETY LABEL		
23.	GASKET SET & TOOL		

Fig.1. CYLINDER BLOCK

(A)=4TNE84-P
(B)=
(C)=

(D)=
(E)=
(F)=

Y00D6410
4TNE84-P

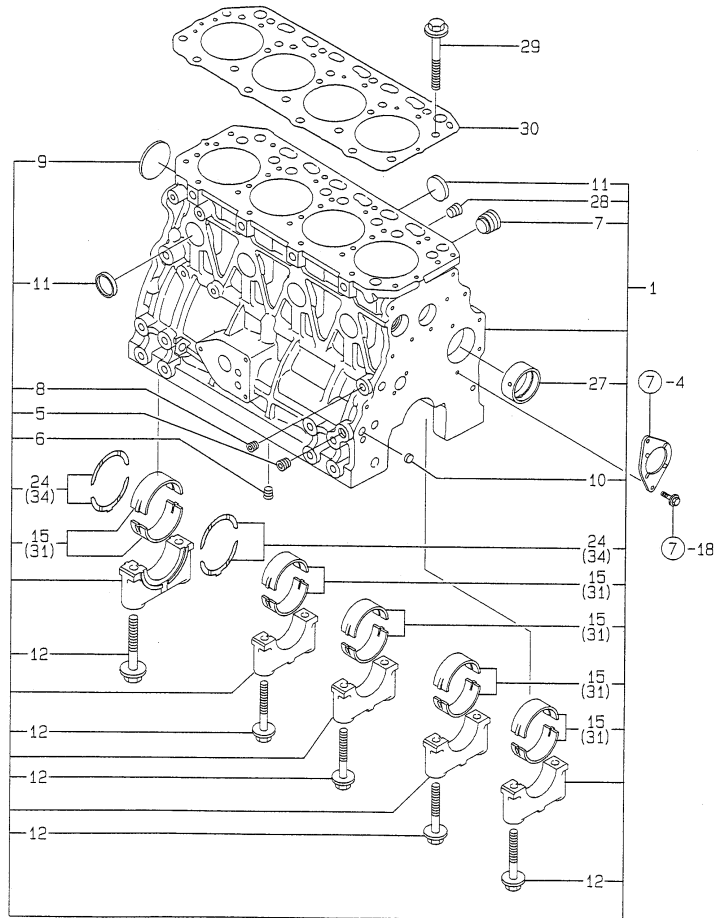

No.	Lev.	Parts No.	Description	Q'ty						I	R
				(A)	(B)	(C)	(D)	(E)	(F)		
1	1	729408-01560	BLOCK ASSY, CYLINDER	1							
5	2	124160-01910	PLUG, PT1/4	2							
6	2	124160-01910	PLUG, PT1/4	1							
7	2	171051-01921	PLUG, NPTF1	1							
8	2	23871-010000	PLUG, R01	1							
9	2	27231-500000	PLUG 50	1							
10	2	27241-120000	PLUG, 12	2							
11	2	27241-300000	PLUG 30	8							
12	2	129150-02020	BOLT, METAL CAP	10							
15	2	129001-02800	BEARING, MAIN	5							
24	2	129150-02930	BEARING, THRUST	2							
27	2	129795-02411	BUSH, CAMSHAFT	1							
28	2	23871-030000	PLUG, R03	1							
29	1	129150-01200	BOLT, HEAD	18							
30	1	129408-01330	GASKET, HEAD	1							
31	1	129150-02870	BEARING, 0.25 US	5							1
34	1	129150-02940	BEARING, THRUST 0.25	2							2

Remarks

- (1) UNDER-SIZE(U.S=0.25)PART.
- (2) OVER-SIZE(O.S=0.25)PART.

Fig.2. GEAR HOUSING

(A)=4TNE84-P
(B)=
(C)=

(D)=
(E)=
(F)=

Y00D6410
4TNE84-P

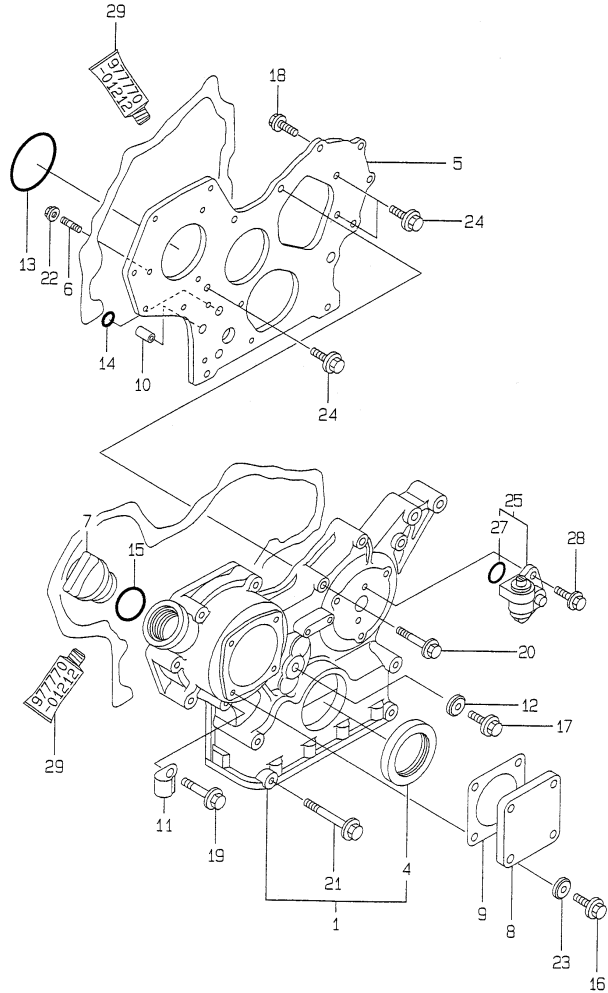

No.	Lev.	Parts No.	Description	Q'ty						I	R
				(A)	(B)	(C)	(D)	(E)	(F)		
1	1	719810-01500	CASE ASSY, GEAR	1							
4	2	129795-01800	SEAL, OIL	1							
5	1	129400-01520	FLANGE, GEAR CASE	1							
6	1	121450-01560	STUD, M8X22	3							
7	1	124160-01751	COVER, FILLER	1							
8	1	124240-01871	COVER	1							
9	1	124240-01883	GASKET	1							
10	1	129795-01950	PIPE, KNOCK L=18	2							
11	1	129150-03100	RETAINER, PIPE	1							
12	1	22190-080002	WASHER, SEAL 6	1							
13	1	121850-51960	O-RING	1							
14	1	24311-000160	O-RING, 1AP16.0	2							
15	1	24311-000320	O-RING, 1AP32.0	1							
16	1	26106-080122	BOLT, M8X 12 PLATED	4							
17	1	26106-080162	BOLT, M8X 16 PLATED	1							
18	1	26106-080202	BOLT, M8X 20 PLATED	2							
19	1	26106-080452	BOLT, M8X 45 PLATED	6							
20	1	26106-080552	BOLT, M8X 55 PLATED	3							
21	1	26106-080852	BOLT, M8X 85 PLATED	4							
22	1	26366-080002	NUT, M8	3							
23	1	22190-080002	WASHER, SEAL 6	4							
24	1	26106-080162	BOLT, M8X 16 PLATED	3							
25	1	129150-91400	GEAR	1							
27	2	24341-000240	O-RING, 1AS24.0	1							
28	1	26106-060162	BOLT, M6X 16 PLATED	2							
29	1	977770-01212	GASKET, LIQUID	1							1

Remarks
(1) OPTIONAL PART.

Fig.3. FLYWHEEL HOUSING & OIL SUMP

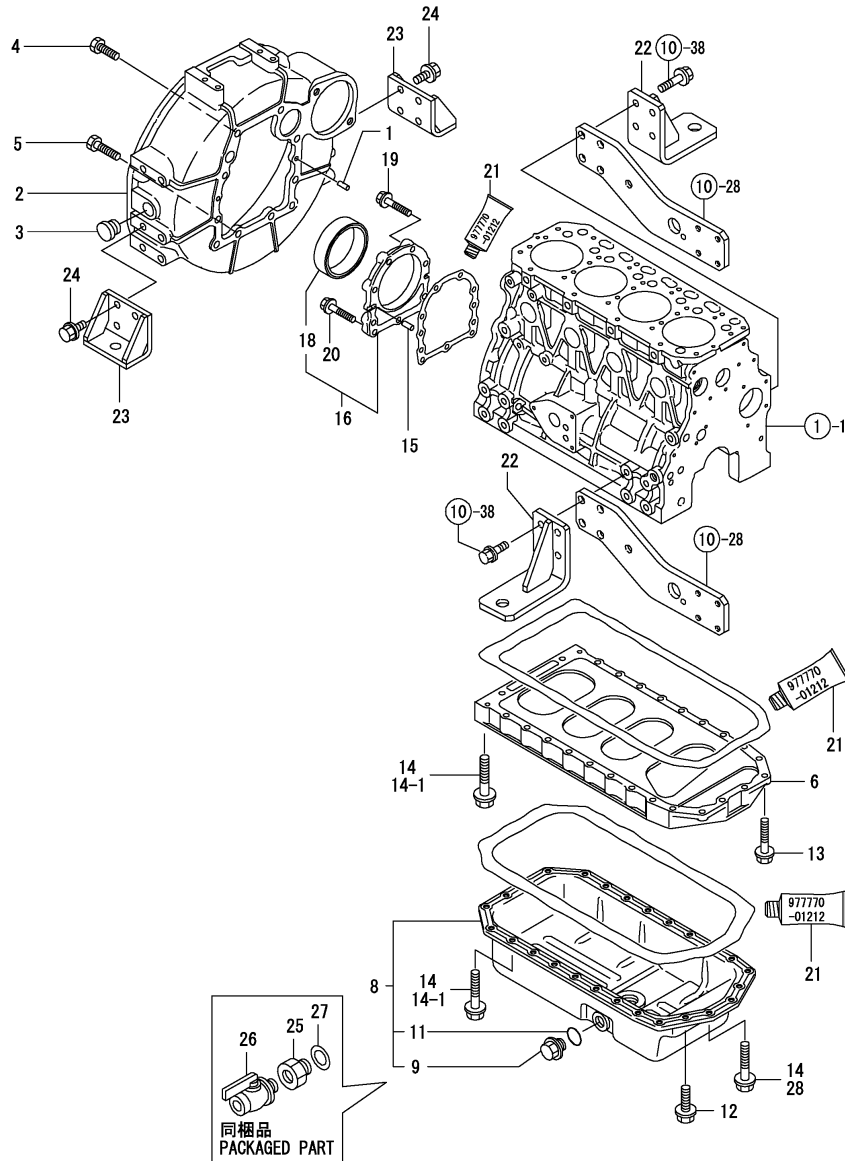

(A)=4TNE84-P
(B)=
(C)=

(D)=
(E)=
(F)=

No.	Lev.	Parts No.	Description	Q'ty						I	R
				(A)	(B)	(C)	(D)	(E)	(F)		
1	1	129100-01580	PIN, M8X16	2							
2	1	119888-01600	HOUSING, FLYWHEEL	1							
3	1	119620-01750	CAP	1							
4	1	26206-100252	BOLT, M10X 25 PLATED	6							
5	1	26206-100302	BOLT, M10X 30 PLATED	4							
6	1	129400-01730	SPACER, OIL SUMP	1							
8	1	129400-01770	SUMP ASSY, OIL	1							
8-1	1	129688-01780	OIL PAN ASSY, DEEP	1						N	2
(A=REF. TO R)											
9	2	171031-01640	PLUG, DRAIN M22	1							
11	2	24341-000250	O-RING, 1AS25.0	1							
12	1	26106-080162	BOLT, M8X 16 PLATED	4							
13	1	26106-080252	BOLT, M8X 25 PLATED	2							
14	1	26106-080452	BOLT, M8X 45 PLATED	24							
14-1	1	26106-080452	BOLT, M8X 45 PLATED	20							K
(A=FROM 1ST)											
15	1	129100-01580	PIN, M8X16	2							
16	1	129100-01640	CASE ASSY, OIL SEAL	1							
18	2	129795-01780	SEAL, OIL	1							
19	1	129486-01670	BOLT, M8X30	6							
20	1	26106-080352	BOLT, M8X 35 PLATED	3							
21	1	977770-01212	GASKET, LIQUID	1							1
22	1	129188-08100	FOOT	2							
23	1	119888-08110	FOOT	2							
24	1	26106-100202	BOLT, M10X 20 PLATED	8							
25	1	129113-01740	SOCKET, M22XPT3/8	1							
26	1	104200-11920	COCK, WATER	1							
27	1	23414-220000	GASKET, 22X1.0	1							
28	1	26106-080502	BOLT, M8X 50 PLATED	4							W
(A=FROM 1ST)											

Remarks
(1)Optional parts.
(2)For repair.

Fig.4. CYLINDER HEAD & BONNET

(A)=4TNE84-P

(B)=

(C)=

(D)=

(E)=

(F)=

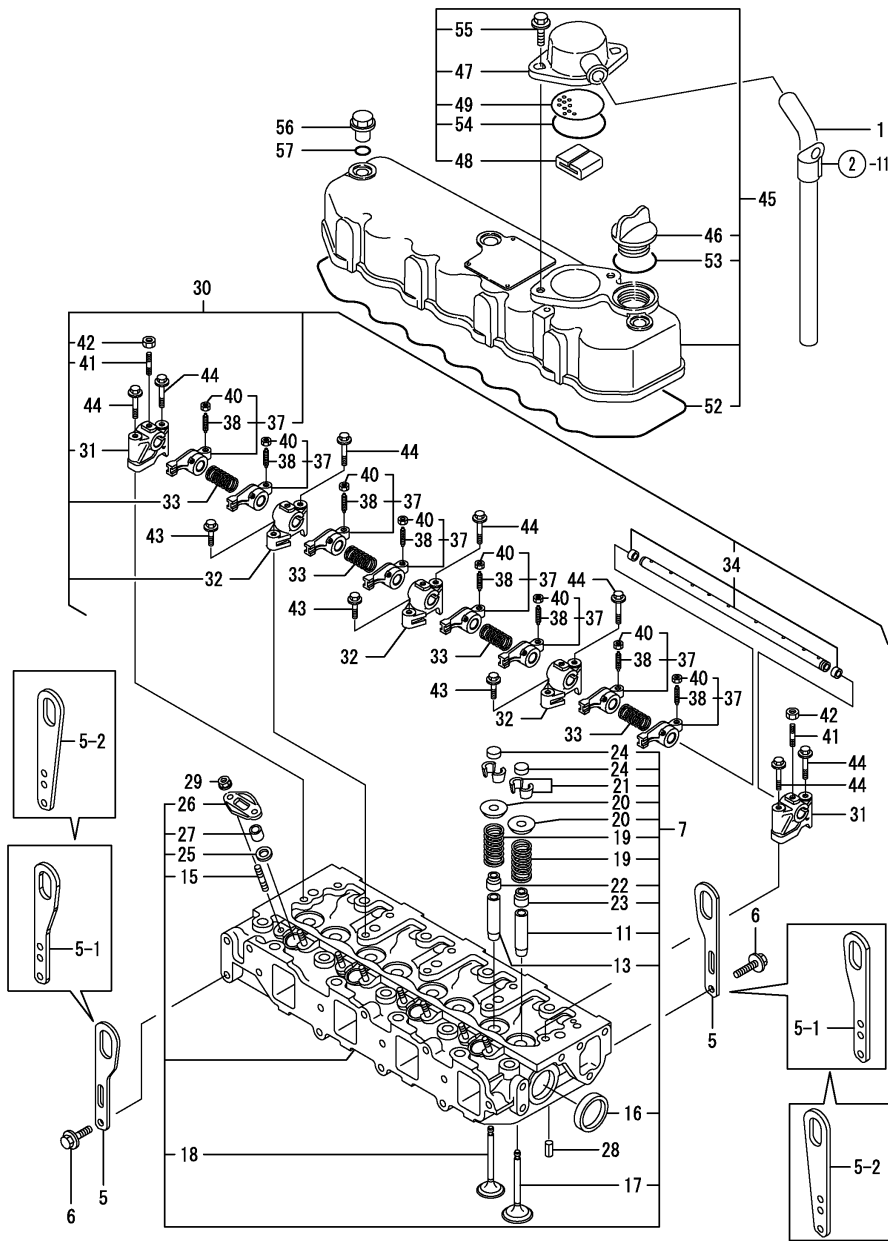

No.	Lev.	Parts No.	Description	Q'ty						I	R
				(A)	(B)	(C)	(D)	(E)	(F)		
1	1	129150-03090	HOSE, ID16X2T	1							
5	1	124736-07900	LIFTER	2							
5-1	1	129604-07900	LIFTER	2							N
(A=*2009.05)											
5-2	1	129900-07900	LIFTER	2							N
(A=*2009.08)											
6	1	26106-080142	BOLT, M8X 14 PLATED	4							
7	1	129407-11700	HEAD ASSY, CYLINDER	1							
11	2	120130-11860	GUIDE, VALVE	4							1
13	2	129150-11810	GUIDE, VALVE	4							1
15	2	26216-060202	STUD, M6X 20	8							
16	2	27241-400000	PLUG, 40	2							
17	2	129100-11100	VALVE, INTAKE	4							
18	2	129100-11110	VALVE, EXHAUST	4							
19	2	129795-11120	SPRING, VALVE	8							
20	2	129795-11180	RETAINER, SPRING	8							
21	2	27310-080001	COTTER, 8	8							
22	2	121400-11340	SEAL, VALVE STEM	4							
23	2	124460-11340	SEAL, VALVE STEM	4							
24	2	129150-11370	CAP, VALVE	8							
25	2	119625-11880	SEAT, NOZZLE	4							
26	2	119625-11900	RETAINER, NOZZLE	4							
27	2	119625-11871	PROTECTOR, NOZZLE	4							
28	1	22351-060012	PIN, SPRING 6.0X12	2							
29	1	26366-060002	NUT, M6	8							
30	1	129500-11240	SHAFT ASSY, ROCKER	1							
31	2	129155-11260	SUPPORT, ROCKER ARM	2							
32	2	129155-11270	SUPPORT, ROCKER ARM	3							
33	2	129150-11280	SPRING	4							
34	2	129550-11290	SHAFT, ROCKER ARM	1							
37	2	129100-11650	ARM, ROCKER	8							
38	3	129150-11230	SCREW, VALVE ADJUST	8							
40	3	129150-11750	NUT, M8	8							
41	2	26226-080182	STUD, M8X 18	3							
42	2	26756-080002	NUT, LOCK M8	3							
43	1	26106-080252	BOLT, M8X 25 PLATED	3							
44	1	26106-080502	BOLT, M8X 50 PLATED	7							
45	1	129400-11350	BONNET ASSY, HEAD	1							
46	2	124160-01751	COVER, FILLER	1							
47	2	129150-03020	COVER, BREATHER	1							
48	2	129150-03070	BAFFLE, BREATHER	1							
49	2	129150-03080	PLATE, BAFFLE	1							
52	2	129550-11310	GASKET, BONNET	1							
53	2	24311-000320	O-RING, 1AP32.0	1							
54	2	24341-000500	O-RING, 1AS50.0	1							
55	2	26106-080162	BOLT, M8X 16 PLATED	2							
56	1	124160-11360	KNOB	3							
57	1	24311-000120	O-RING, 1AP12.0	3							

Remarks

(1) REPAIR PART.

N:Old $\begin{matrix} \leftarrow \text{Yes} \\ \text{No} \end{matrix}$ New, Q:Old $\begin{matrix} \leftarrow \text{No} \\ \text{Yes} \end{matrix}$ New, R:Old $\begin{matrix} \leftarrow \text{Yes} \\ \text{Yes} \end{matrix}$ New, S:Old $\begin{matrix} \leftarrow \text{No} \\ \text{No} \end{matrix}$ New, W:Add, Z:Discontinued, F:Interchangeable by set, K:Q'ty Change

Fig.5. SUCTION MANIFOLD & AIR CLEANER

(A)=4TNE84-P
(B)=
(C)=

(D)=
(E)=
(F)=

Y00D6410
4TNE84-P

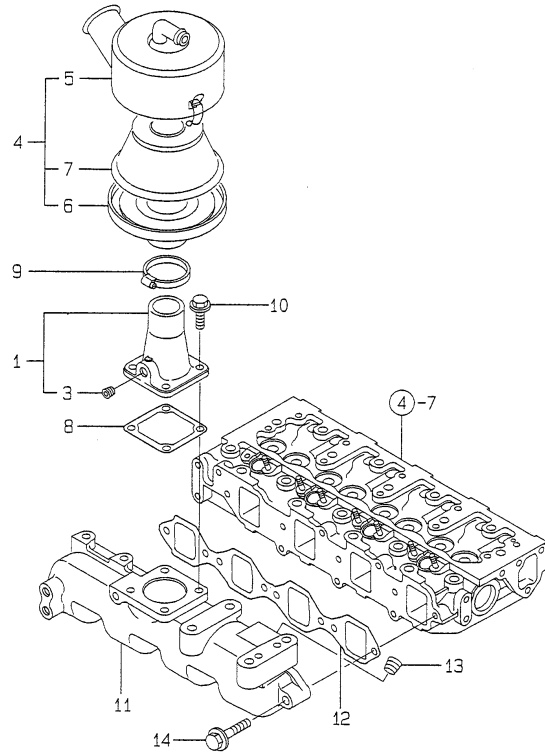

No.	Lev.	Parts No.	Description	Q'ty						I	R
				(A)	(B)	(C)	(D)	(E)	(F)		
1	1	129470-12210	JOINT ASSY	1							
3	2	23871-010000	PLUG, R01	1							
4	1	129795-12501	SILENCER ASSY	1							
5	2	129795-12520	PIPE, AIR INTAKE	1							
6	2	129795-12530	PLATE	1							
7	2	129795-12540	ELEMENT	1							
8	1	129150-77511	GASKET	1							
9	1	23000-060000	CLAMP, 60	1							
10	1	26106-080162	BOLT, M8X 16 PLATED	4							
11	1	129400-12100	MANIFOLD, AIR INTAKE	1							
12	1	129550-12111	GASKET, MANIFOLD	1							
13	1	23871-030000	PLUG, R03	1							
14	1	26106-080352	BOLT, M8X 35 PLATED	5							

Fig.6. EXHAUST MANIFOLD & SILENCER

(A)=4TNE84-P
(B)=
(C)=

(D)=
(E)=
(F)=

Y00D6410
4TNE84-P

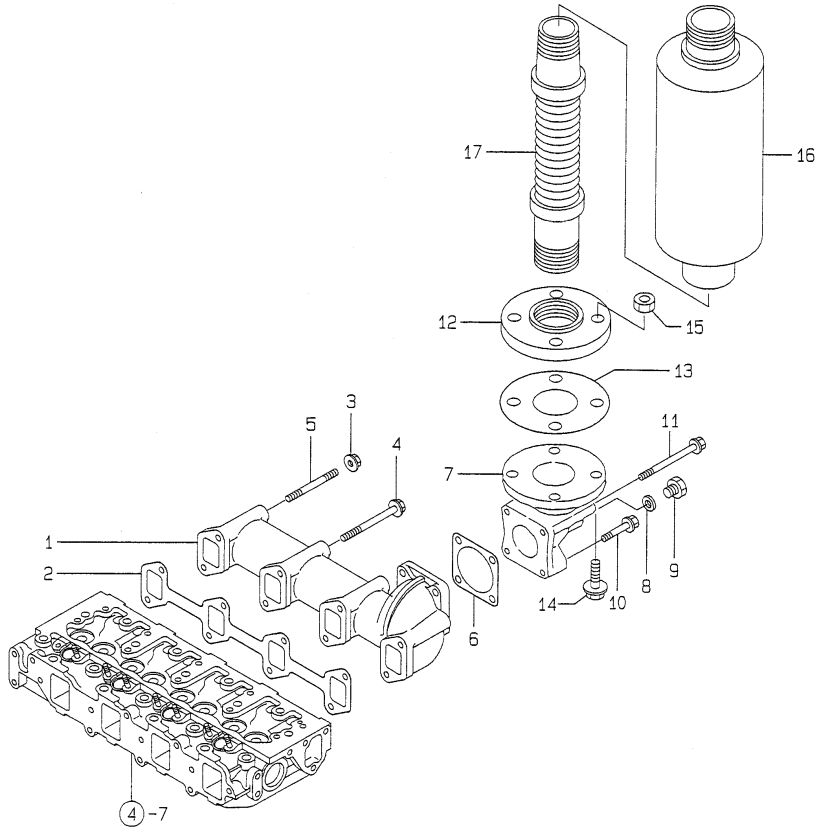

No.	Lev.	Parts No.	Description	Q'ty						I	R
				(A)	(B)	(C)	(D)	(E)	(F)		
1	1	129400-13101	MANIFOLD, EXHAUST	1							
2	1	129550-13110	GASKET	1							
3	1	194990-22050	NUT, M8	2							
4	1	26106-080802	BOLT, M8X 80 PLATED	6							
5	1	26216-080802	STUD, M8X 80	2							
6	1	129400-13201	GASKET, SILENCER	1							
7	1	129411-13300	BEND, EXHAUST 50A	1							
8	1	23414-170000	GASKET, 17X1.0	1							
9	1	23894-030002	PLUG, G3/8	1							
10	1	26106-080452	BOLT, M8X 45 PLATED	2							
11	1	26106-080952	BOLT, M8X 95 PLATED	2							
12	1	23217-050000	FLANGE, 5K 50	1							
13	1	23446-050000	GASKET 50	1							
14	1	26116-120502	BOLT, M12X 50 PLATED	4							
15	1	26716-120002	NUT, M12	4							
16	1	43100-552900	SILENCER	1							
17	1	43720-500120	PIPE	1							

Fig.8. CRANKSHAFT & PISTON

(A)=4TNE84-P
(B)=
(C)=

(D)=
(E)=
(F)=

Y0006410
4TNE84-P

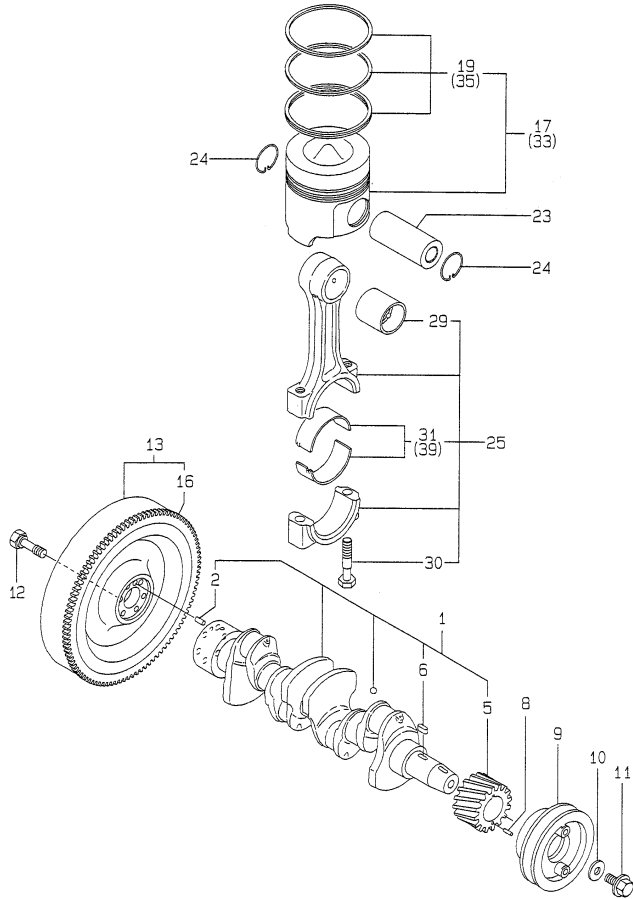

No.	Lev.	Parts No.	Description	Q'ty						I	R
				(A)	(B)	(C)	(D)	(E)	(F)		
1	1	129407-21000	CRANKSHAFT ASSY	1							
2	2	129100-01580	PIN, M8X16	1							
5	2	129150-21200	GEAR, CRANKSHAFT	1							
6	2	22512-070140	KEY, 7X 14	1							
8	1	22351-040010	PIN, SPRING 4.0X10	1							
9	1	129550-21650	V-PULLEY	1							
10	1	129795-21661	WASHER	1							
11	1	121850-21680	BOLT	1							
12	1	121111-21501	BOLT, FLYWHEEL	6							
13	1	129488-21590	FLYWHEEL ASSY	1							
16	2	119865-21600	GEAR, RING	1							
17	1	129002-22081	PISTON ASSY	4							
19	2	129002-22500	RING SET, PISTON	4							
23	1	129202-22300	PIN, PISTON D26 L70	4							
24	1	22252-000260	RING, 26	8							
25	1	729402-23100	ROD ASSY, CONNECTING	4							
29	2	129100-23910	BEARING, PISTON PIN	4							1
30	2	121550-23200	BOLT, CONNECTING ROD	8							
31	2	129150-23600	BEARING, CRANK PIN	4							
33	1	129002-22901	PISTON ASSY, 0.25 OS	4							2
35	2	129002-22950	RING SET, 0.25 OS	4							2
39	1	129150-23610	BEARING, 0.25 US	4							3

Remarks

- (1) REPAIR PART.
- (2) OVER-SIZE(O.S=0.25)PART.
- (3) UNDER-SIZE(U.S=0.25)PART.

Fig.9. LUB.OIL SYSTEM

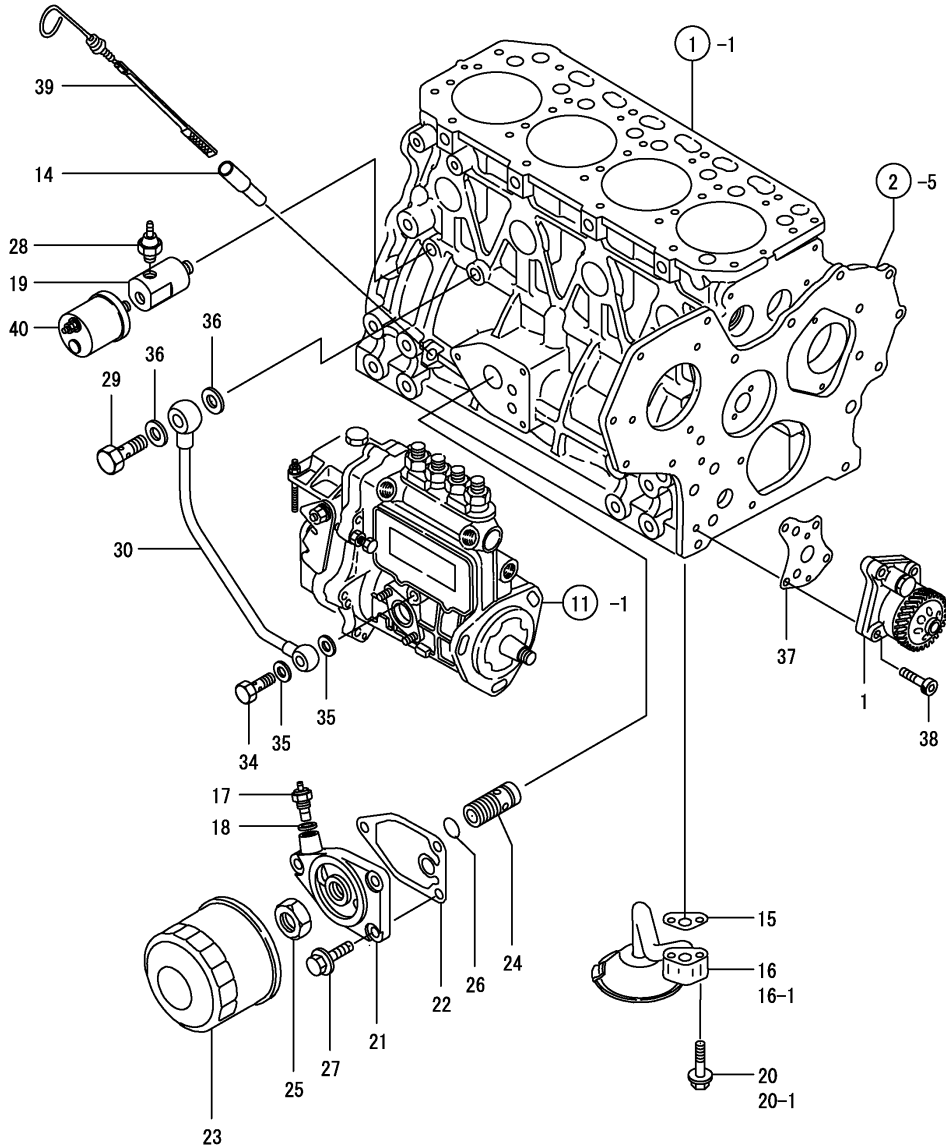

(A)=4TNE84-P
(B)=
(C)=

(D)=
(E)=
(F)=

No.	Lev.	Parts No.	Description	Q'ty						I	R
				(A)	(B)	(C)	(D)	(E)	(F)		
1	1	129407-32000	PUMP ASSY, OIL	1							
14	1	121520-34810	GUIDE, DIPSTICK	1							
15	1	129150-35041	GASKET	1							
15-1	1	129150-35042 (A=EZZZZZ)	GASKET	1							N
16	1	129436-35091	PIPE ASSY, OIL INLET	1							
16-1	1	129436-35070 (A=EZZZZZ)	PIPE ASSY	1							S
17	1	124250-49351	SENSOR	1							
18	1	129150-49360	GASKET	1							
19	1	171375-39601	DAMPER, 1/8	1							
20	1	26106-080352	BOLT, M8X 35 PLATED	2							
20-1	1	26106-080552 (A=EZZZZZ)	BOLT, M8X 55 PLATED	2							S
21	1	171375-35100	BRACKET, STRAINER	1							
22	1	129150-35111	GASKET	1							
23	1	129150-35151	FILTER, D80XL80	1							
24	1	129001-35300	BOLT, FILTER	1							
25	1	129150-35350	NUT	1							
26	1	24311-000160	O-RING, 1AP16.0	1							
27	1	26106-080202	BOLT, M8X 20 PLATED	3							
28	1	124160-39450	SWITCH, 0.5KG	1							
29	1	124160-39140	BOLT, PIPE JOINT M10	1							
30	1	129550-39450	PIPE ASSY, OIL	1							
34	1	124550-59820	BOLT, PIPE JOINT M8	1							
35	1	22190-080002	WASHER, SEAL 6	2							
36	1	23414-100000	GASKET, 10X1.0	2							
37	1	129150-32020	GASKET, PUMP	1							
38	1	26450-060252	BOLT, M6X 25	4							
39	1	129136-34800	DIPSTICK, OIL	1							
40	1	144626-91560	SENSOR	1							

Fig.10. COOLING WATER SYSTEM

(A)=4TNE84-P

(B)=

(C)=

(D)=

(E)=

(F)=

Y00D6410
4TNE84-P

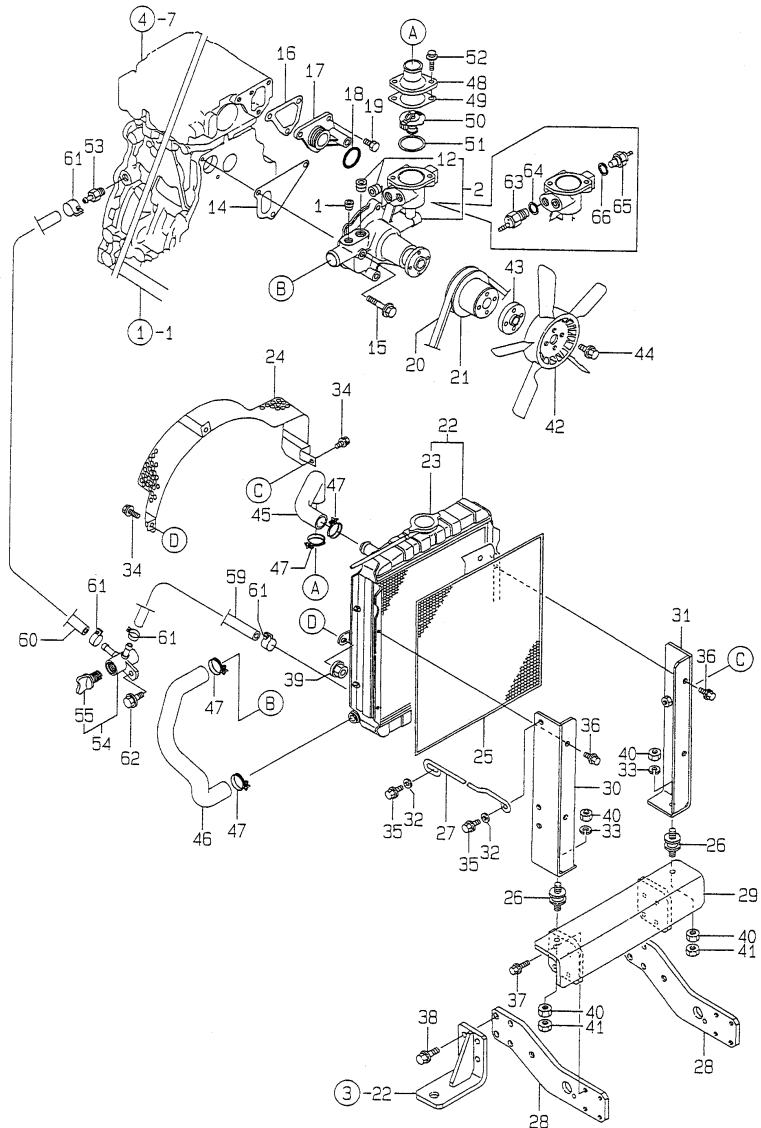

No.	Lev.	Parts No.	Description	Q'ty						I	R
				(A)	(B)	(C)	(D)	(E)	(F)		
1	1	121850-11860	PLUG, PT1/4	1							
2	1	129001-42002	PUMP ASSY, WATER	1							
12	2	23871-030000	PLUG, R03	2							
14	1	129100-42020	GASKET, WATER PUMP	1							
15	1	26106-080602	BOLT, M8X 60 PLATED	3							
16	1	129100-49840	GASKET	1							
17	1	129001-42040	JOINT	1							
18	1	24321-000300	O-RING, 1AG30.0	1							
19	1	26106-080162	BOLT, M8X 16 PLATED	3							
20	1	25132-003800	V-BELT, A38	1							
21	1	129155-42350	V-PULLEY	1							
22	1	171440-44500	RADIATOR	1							
23	2	123682-44210	CAP, RADIATOR	1							
24	1	129113-44560	PROTECTOR, FAN	1							
25	1	121250-44581	SCREEN, RADIATOR	1							
26	1	121400-44650	ABSORBER	2							
27	1	129413-44940	RETAINER, RADIATOR	1							
28	1	129188-44950	BRACKET	2							
29	1	129188-44960	BRACKET, RADIATOR	1							
30	1	129188-44970	SUPPORT, A	1							
31	1	129188-44980	SUPPORT, B	1							
32	1	22137-080000	WASHER, 8	2							
33	1	22217-100000	WASHER, SPRING 10	2							
34	1	26106-080122	BOLT, M8X 12 PLATED	3							
35	1	26106-080162	BOLT, M8X 16 PLATED	2							
36	1	26106-080202	BOLT, M8X 20 PLATED	4							
37	1	26106-080252	BOLT, M8X 25 PLATED	8							
38	1	26106-100302	BOLT, M10X 30 PLATED	8							
39	1	26366-080002	NUT, M8	3							
40	1	26716-100002	NUT, M10	4							
41	1	26756-100002	NUT, LOCK M10	2							
42	1	171340-44740	FAN, COOLING D335XNF	1							
43	1	124574-44761	SPACER, FAN	1							
44	1	26014-060252	BOLT, M6X 25	4							
45	1	171301-49010	PIPE, WATER	1							
46	1	129211-49020	PIPE, WATER	1							
47	1	23010-038000	CLAMP, 38	4							
48	1	129350-49560	COVER, THERMOSTAT	1							
49	1	129795-49551	GASKET	1							
50	1	129155-49800	THERMOSTAT, 71	1							
51	1	129150-49811	GASKET, THERMOSTAT	1							
52	1	26106-080202	BOLT, M8X 20 PLATED	2							
53	1	121550-49111	JOINT, PT1/4	1							
54	1	129150-49100	COCK ASSY, 3-WAY	1							
55	2	129150-49080	COCK, DRAIN	1							
59	1	121520-49160	PIPE, WATER DRAIN	1							
60	1	121456-49160	PIPE, WATER DRAIN	1							
61	1	124766-59050	CLIP, HOSE 12	4							
62	1	26106-080162	BOLT, M8X 16 PLATED	1							
63	1	121250-44901	SWITCH, 110	1							
64	1	124465-44950	GASKET, 16	1							

Fig.10. COOLING WATER SYSTEM

(A)=4TNE84-P
(B)=
(C)=

(D)=
(E)=
(F)=

Y00D6410
4TNE84-P

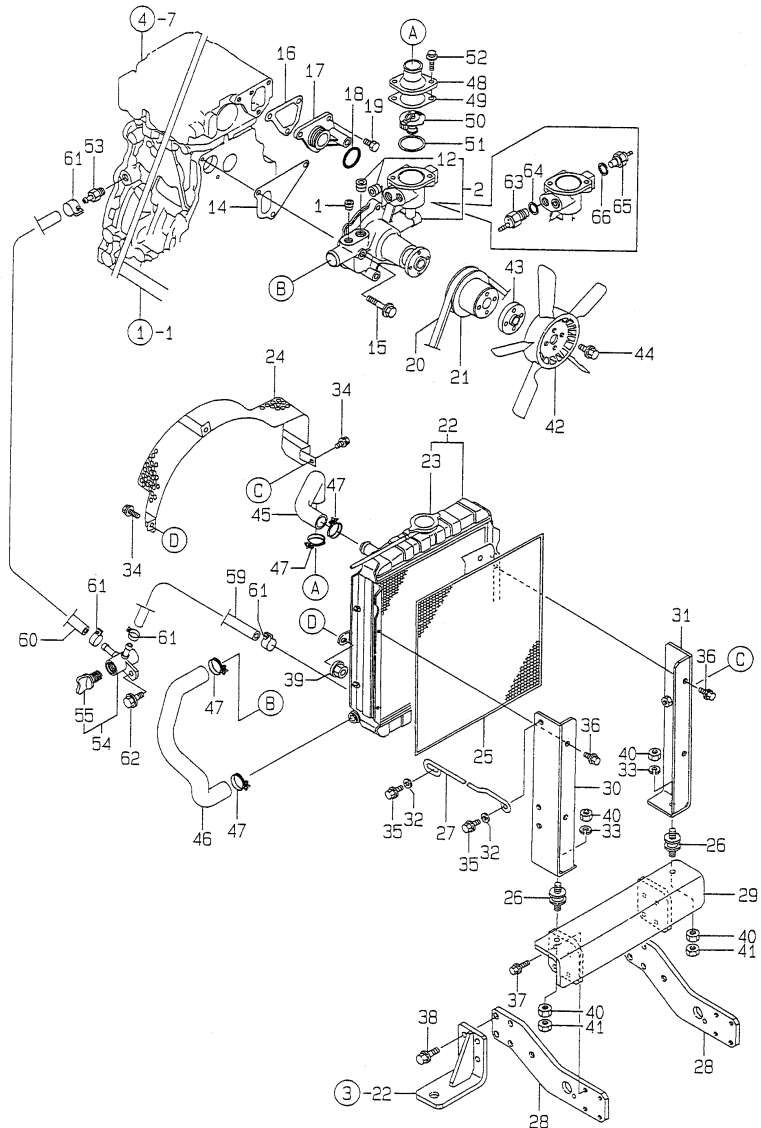

No.	Lev.	Parts No.	Description	Q'ty						I	R
				(A)	(B)	(C)	(D)	(E)	(F)		
65	1	124250-49351	SENSOR	1							
66	1	129150-49360	GASKET	1							

Fig.11. FUEL INJECTION PUMP

(A)=4TNE84-P
(B)=
(C)=

(D)=
(E)=
(F)=

Y00D6410
4TNE84-P

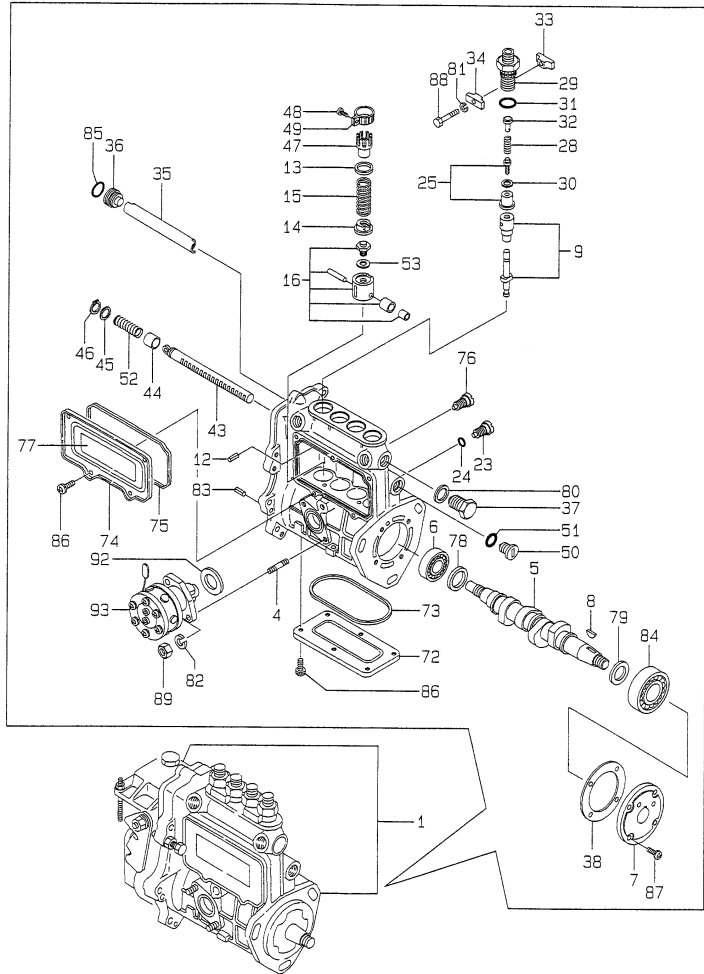

No.	Lev.	Parts No.	Description	Q'ty						I	R
				(A)	(B)	(C)	(D)	(E)	(F)		
1	1	729408-51320	PUMP ASSY, INJECTION	1							1
4	2	129155-51020	STUD	2							
5	2	129470-51040	CAMSHAFT	1							
6	2	129155-51050	BEARING, 17BM001D	1							
7	2	129155-51060	SUPPORT, CAMSHAFT	1							
8	2	122710-51090	KEY	1							
9	2	129470-51101	PLUNGER ASSY	4							
12	2	129155-51140	PIN	4							
13	2	174307-51170	RETAINER, SPRING A	4							
14	2	129155-51180	RETAINER, SPRING	4							
15	2	124950-51190	SPRING, PLUNGER	4							
16	2	129155-51200	TAPPET ASSY	4							
23	2	129155-51270	STOPPER, TAPPET	4							
24	2	129155-51280	O-RING, S6	4							
25	2	129100-51300	VALVE ASSY, DELIVERY	4							
28	2	129155-51320	SPRING, DELIVERY	4							
29	2	129155-51340	RETAINER	4							
30	2	124550-51350	GASKET, DELIVERY	4							
31	2	124550-51370	O-RING	4							
32	2	129155-51370	STOPPER, VALVE	4							
33	2	129155-51380	STOPPER	2							
34	2	129155-51390	STOPPER	2							
35	2	129555-51400	DEFLECTOR	1							
36	2	129155-51410	BOLT	1							
37	2	129155-51420	PLUG, M16	1							
38	2	129155-51450	SHIM SET, ADJUSTING	1							
43	2	129555-51500	RACK, CONTROL	1							
44	2	129155-51521	BUSH, RACK	1							
45	2	129155-51530	SPACER	1							
46	2	129155-51540	CIRCLIP	1							
47	2	129155-51550	PINION, CONTROL	4							
48	2	122117-51560	SCREW	4							
49	2	174307-51560	PINION	4							
50	2	129155-51570	PLUG, M12	1							
51	2	129155-51580	O-RING	1							
52	2	129155-51591	SPRING, RACK	1							
53	2	129155-51600	SHIM SET, ADJUSTING	4							
72	2	129555-51700	COVER	1							
73	2	129555-51710	GASKET	1							
74	2	129555-51750	COVER	1							
75	2	129555-51760	GASKET	1							
76	2	129155-51790	STOOPER, RACK	1							
77	2	129156-51910	LABEL, CAUTION	1							
78	2	129155-51930	SPACER, T=3.25	1							
79	2	129155-51940	SPACER, T=1.5	1							
80	2	22190-160002	WASHER, SEAL 16	1							
81	2	22217-050000	WASHER, SPRING 5	2							
82	2	22217-060000	WASHER, SPRING 6	2							
83	2	22351-050010	PIN, SPRING 5.0X10	2							
84	2	24101-063034	BEARING, BALL 6303	1							
85	2	24341-000160	O-RING, 1AS16.0	1							

Remarks

(1) GOVERNOR(FIG.NO.12)IS INCORPORATED IN THIS FUEL INJECTION PUMP. (REF.NO.1).

Fig.11. FUEL INJECTION PUMP

(A)=4TNE84-P
(B)=
(C)=

(D)=
(E)=
(F)=

Y00D6410
4TNE84-P

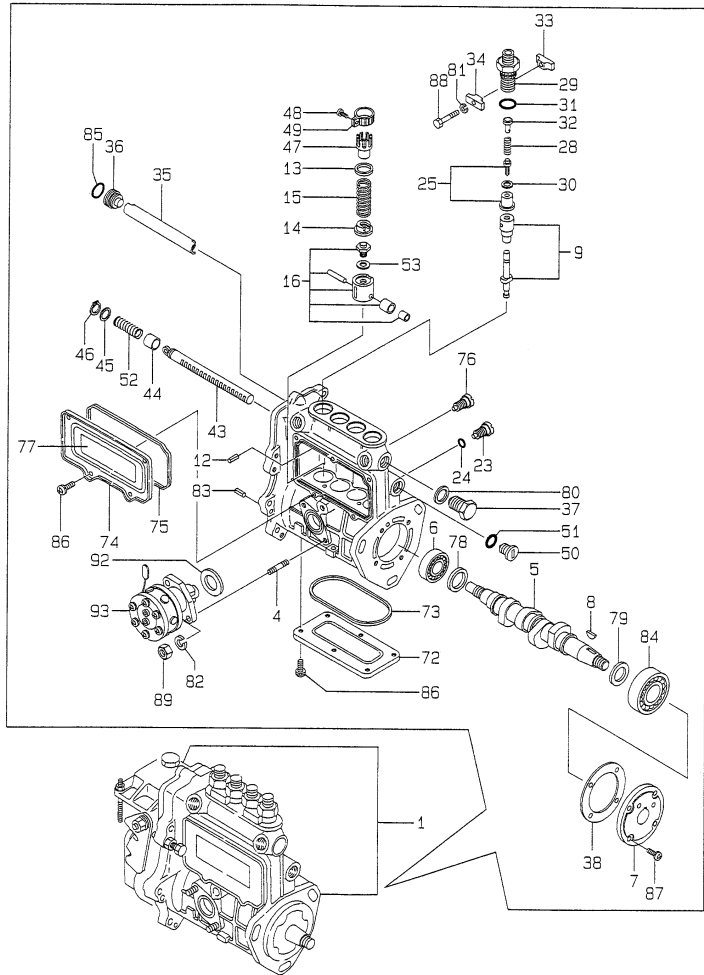

No.	Lev.	Parts No.	Description	Q'ty						I	R
				(A)	(B)	(C)	(D)	(E)	(F)		
86	2	26022-050102	SCREW, M5X10	11							
87	2	26022-060162	SCREW, M6X16	4							
88	2	26116-050302	BOLT, M5X 30 PLATED	2							
89	2	26716-060002	NUT, M6	2							
92	2	129155-52050	GASKET	1							
93	2	129491-52100	PUMP ASSY, FUEL FEED	1							

Remarks
(1) GOVERNOR(FIG.NO.12)IS INCORPORATED IN THIS FUEL INJECTION PUMP.
(REF.NO.1).

Fig.12. GOVERNOR

(A)=4TNE84-P
(B)=
(C)=

(D)=
(E)=
(F)=

Y00D6410
4TNE84-P

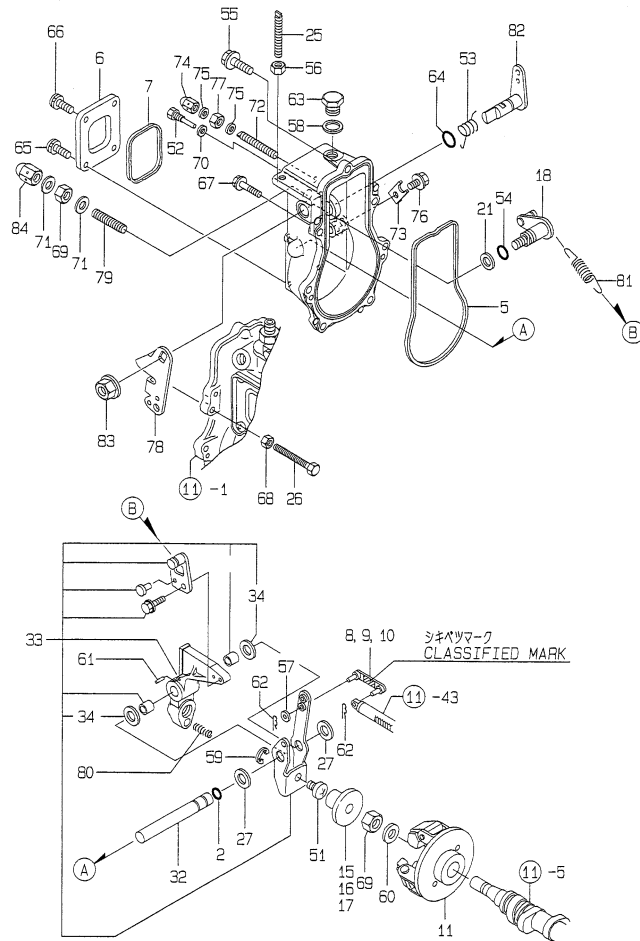

No.	Lev.	Parts No.	Description	Q'ty						I	R
				(A)	(B)	(C)	(D)	(E)	(F)		
2	2	129155-51280	O-RING, S6	1							
5	2	129155-61050	GASKET	1							
6	2	129155-61060	COVER, GOVERNOR CASE	1							
7	2	129155-61070	GASKET	1							
8	2	129155-61120	LINK, L=30 MARK 0	1							1
9	2	129155-61130	LINK, L=31 MARK 1	1							1
10	2	129155-61140	LINK, L=30.5 MARK 05	1							1
11	2	171488-61200	WEIGHT ASSY,GOVERNOR	1							
15	2	129155-61341	SLEEVE	1							2
16	2	129155-61350	SLEEVE, L=24.9	1							2
17	2	129155-61360	SLEEVE, L=25.2	1							2
18	2	129100-61400	SHAFT ASSY	1							
21	2	129155-61430	SPACER	1							
25	2	129155-61450	BOLT, LIMITER	1							
26	2	129155-61460	BOLT, IDLE	1							
27	2	129155-61480	SPACER ASSY	2							
32	2	129660-61491	SHAFT	1							
33	2	129100-61501	LEVER ASSY, GOVERNOR	1							
34	3	174307-51700	SHIM SET	2							
51	2	129155-61540	SHIFTER	1							
52	2	129155-61810	PIN	1							
53	2	129100-61821	SPRING, RETURN	1							
54	2	129155-61830	O-RING, S10	1							
55	2	129155-61950	BOLT	1							
56	2	124550-66370	NUT, M6	1							
57	2	22117-04000	WASHER, 4	1							
58	2	22190-100002	WASHER, SEAL 10	1							
59	2	22272-000040	RING, E- 4	1							
60	2	22287-120000	WASHER, 12	1							
61	2	22351-030016	PIN, SPRING 3.0X16	1							
62	2	22372-040000	PIN, SNAP 4	2							
63	2	23887-100002	PLUG, 10	1							
64	2	24311-240100	O-RING, 1AP10A	1							
65	2	26022-050102	SCREW, M5X10	2							
66	2	26023-050102	SCREW, M5X10	2							
67	2	26106-060202	BOLT, M6X 20 PLATED	6							
68	2	26756-060002	NUT, LOCK M6	1							
69	2	26776-120002	NUT, LOCK M12	2							
70	2	22190-060002	WASHER, SEAL 6	1							
71	2	22190-120002	WASHER, SEAL 12	2							
72	2	129155-61450	BOLT, LIMITER	1							
73	2	119660-61901	RETAINER, SHAFT	1							
74	2	119600-66840	NUT, CAP	1							
75	2	22190-060002	WASHER, SEAL 6	2							
76	2	26106-060102	BOLT, M6X 10 PLATED	1							
77	2	26756-060002	NUT, LOCK M6	1							
78	2	129100-61440	LEVER, CONTROL	1							
79	2	129155-61470	BOLT, CONTROL	1							
80	2	129500-61650	SPRING, FUEL CONTROL	1							
81	2	129477-61710	SPRING, GOVERNOR	1							
82	2	129400-61801	LEVER, STOP	1							

Remarks

- (1) SELECTIVE PARTS : CERTAIN THE CLASSIFICATION MARK, THEN PLACE YOUR ORDER.(ILLUSTRATION)
- (2) SELECTIVE PARTS.

Fig.12. GOVERNOR

(A)=4TNE84-P
(B)=
(C)=

(D)=
(E)=
(F)=

Y00D6410
4TNE84-P

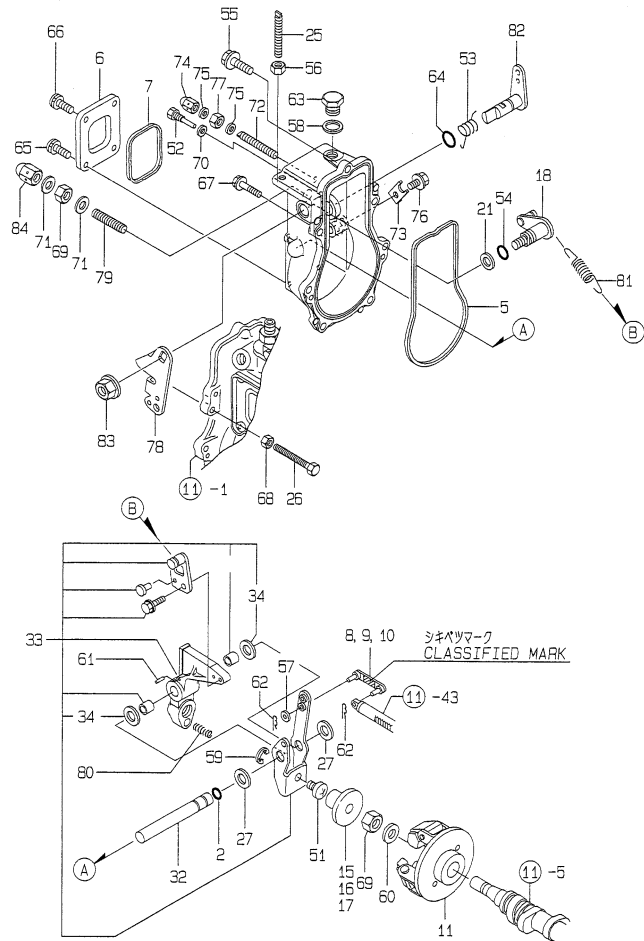

No.	Lev.	Parts No.	Description	Q'ty						I	R
				(A)	(B)	(C)	(D)	(E)	(F)		
83	2	26366-080002	NUT, M8	1							
84	2	26687-120002	NUT, CAP M12	1							

Remarks

- (1) SELECTIVE PARTS : CERTAIN THE CLASSIFICATION MARK, THEN PLACE YOUR ORDER.(ILLUSTRATION)
- (2) SELECTIVE PARTS.

Fig.13. FUEL INJECTION VALVE

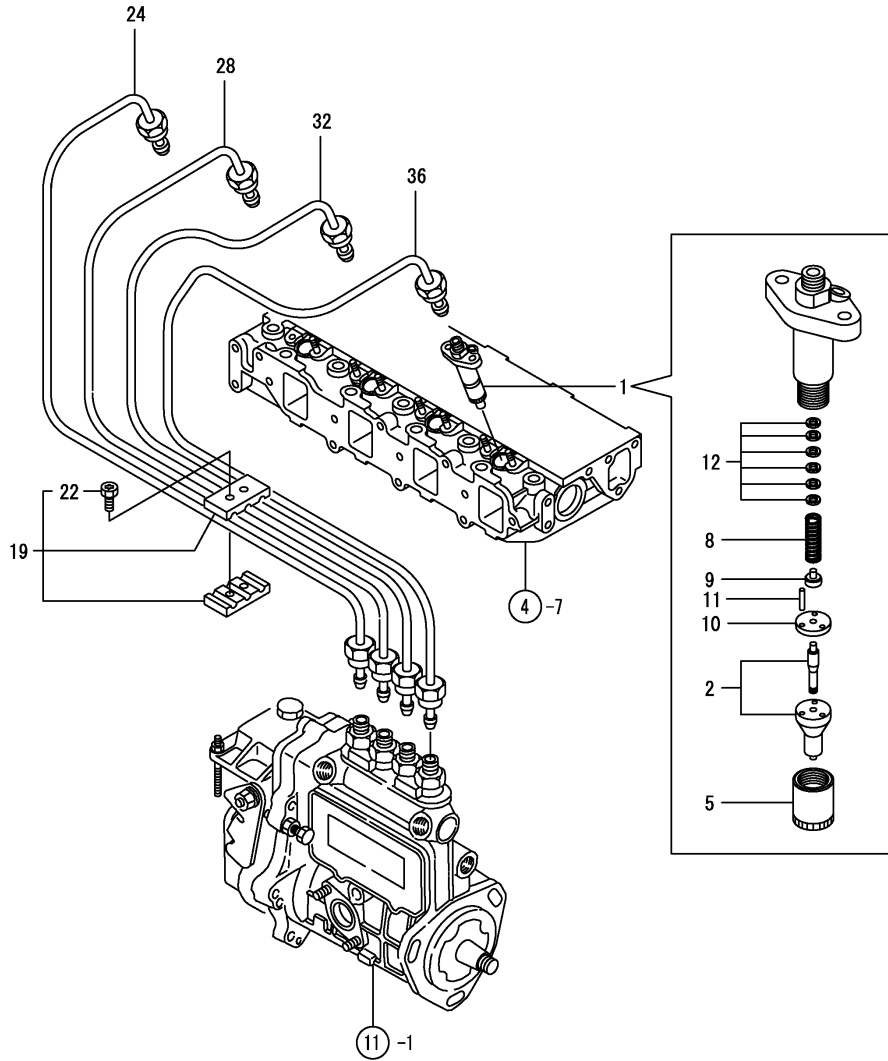

(A)=4TNE84-P
(B)=
(C)=

(D)=
(E)=
(F)=

No.	Lev.	Parts No.	Description	Q'ty						I	R
				(A)	(B)	(C)	(D)	(E)	(F)		
1	1	719810-53100	VALVE ASSY,INJECTION	4							
2	2	119810-53000	VALVE ASSY,INJECTION	4							
5	2	114250-53080	NUT, NOZZLE D16.95	4							
8	2	114250-53120	SPRING, NOZZLE	4							
9	2	114250-53130	SEAT, SPRING	4							
10	2	114250-53140	PLATE	4							
11	2	114250-53210	PIN	8							
12	2	114250-53400	SHIM SET	4							
19	1	129150-59120	RETAINER, PIPE	2							
22	2	129150-59131	BOLT, M4X14	4							
24	1	129400-59910	PIPE ASSY, INJECTION	1							
28	1	129400-59920	PIPE ASSY, INJECTION	1							
32	1	129400-59930	PIPE ASSY, INJECTION	1							
36	1	129400-59940	PIPE ASSY, INJECTION	1							

Fig.14. FUEL OIL TANK

(A)=4TNE84-P
(B)=
(C)=

(D)=
(E)=
(F)=

Y00D6410
4TNE84-P

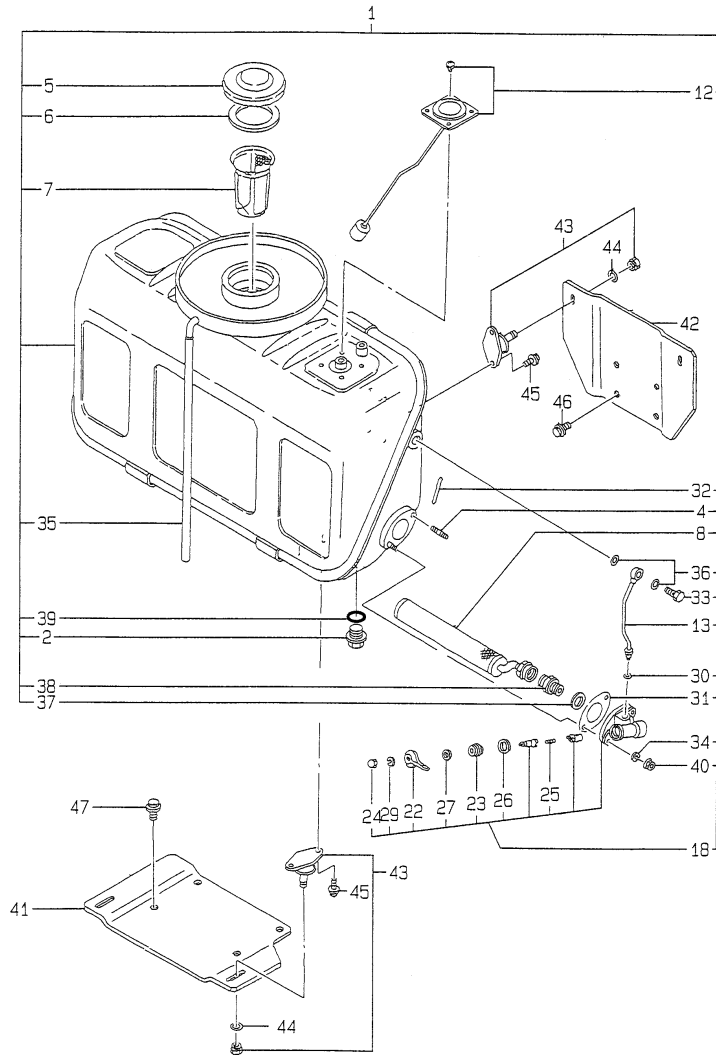

No.	Lev.	Parts No.	Description	Q'ty						I	R
				(A)	(B)	(C)	(D)	(E)	(F)		
1	1	129113-55100	TANK ASSY, FUEL	1							
2	2	124060-01640	PLUG, M12	1							
4	2	26216-060182	STUD, M6X 18	2							
5	2	105302-55040	CAP, FUEL TANK	1							
6	2	101504-55051	GASKET	1							
7	2	101504-55101	STRAINER, FUEL	1							
8	2	129113-55200	STRAINER ASSY, FUEL	1							
12	2	129113-55210	GAUGE, LEVEL	1							
13	2	104300-55250	PIPE	1							
18	2	704800-55310	COCK ASSY, FUEL	1							
22	3	101200-55341	HANDLE	1							
23	3	101200-55351	SEAT, PLUNGER SPRING	1							
24	3	101200-55360	NUT, CAP	1							
25	3	101200-55371	SPRING, VALVE	1							
26	3	101200-55380	GASKET	1							
27	3	101200-55490	O-RING	1							
29	3	22217-060000	WASHER, SPRING 6	1							
30	2	104300-55320	GASKET	1							
31	2	101100-55390	GASKET	1							
32	2	112100-55420	LABEL	1							
33	2	101147-59810	BOLT, PIPE JOINT M8	1							
34	2	22217-060000	WASHER, SPRING 6	2							
35	2	23061-070330	PIPE, 7X 330	1							
36	2	23414-080000	GASKET, 8X1.0	2							
37	2	23414-160000	GASKET, 16X1.0	1							
38	2	23831-100000	UNION, 10	1							
39	2	24311-000140	O-RING, 1AP14.0	1							
40	2	26366-060002	NUT, M6	2							
41	1	129113-55800	BRACKET, FUEL TANK	1							
42	1	129113-55830	SUPPORT	1							
43	1	171048-55850	ABSORBER	4							
44	1	22117-080000	WASHER, 8	4							
45	1	26106-060142	BOLT, M6X 14 PLATED	8							
46	1	26106-080142	BOLT, M8X 14 PLATED	4							
47	1	26106-100182	BOLT, M10X 18 PLATED	4							

Fig.15. FUEL LINE

(A)=4TNE84-P
(B)=
(C)=

(D)=
(E)=
(F)=

Y00D6410
4TNE84-P

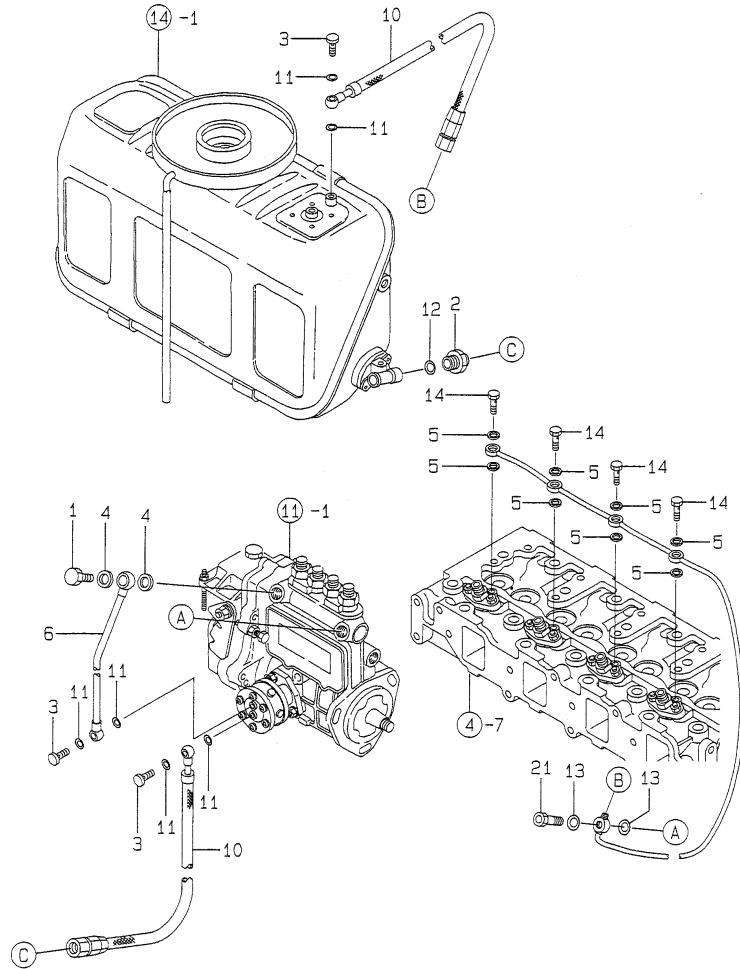

No.	Lev.	Parts No.	Description	Q'ty						I	R
				(A)	(B)	(C)	(D)	(E)	(F)		
1	1	103854-39140	BOLT, PIPE JOINT	1							
2	1	171049-59010	UNION, M18XPT1/4	1							
3	1	105582-59150	BOLT, PIPE JOINT	3							
4	1	22190-120002	WASHER, SEAL 12	2							
5	1	23414-060000	GASKET, 6X1.0	8							
6	1	129113-59510	PIPE ASSY, FUEL	1							
10	1	129113-59600	PIPE, 8AXL800	2							
11	1	23414-080012	GASKET, 8X1.0	6							
12	1	22190-080003	WASHER, SEAL 8	1							
13	1	104200-59170	GASKET, 12	2							
14	1	129491-59540	BOLT, PIPE JOINT M6	4							
15	1	129489-59550	PIPE ASSY, RETURN	1							
21	1	129100-59951	VALVE ASSY, CHECK	1							

Fig.16. ENGINE STOP SOLENOID

(A)=4TNE84-P
(B)=
(C)=

(D)=
(E)=
(F)=

Y00D6410
4TNE84-P

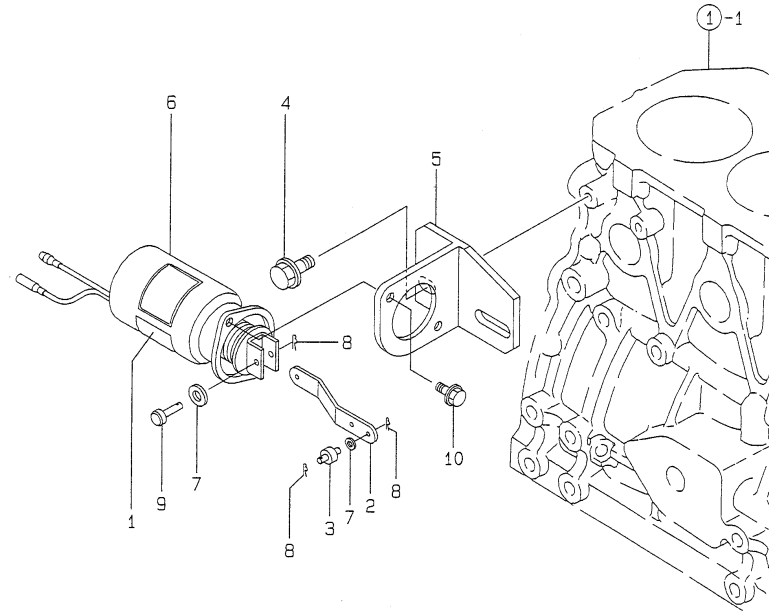

No.	Lev.	Parts No.	Description	Q'ty						I	R
				(A)	(B)	(C)	(D)	(E)	(F)		
1	1	171010-65100	LABEL	1							
2	1	171335-65110	LINK, SOLENOID	1							
3	1	171335-65120	PIN	1							
4	1	26106-080142	BOLT, M8X 14 PLATED	2							
5	1	129410-65130	BRACKET, SOLENOID	1							
6	1	171335-77951	SOLENOID, MAGNETIC	1							
7	1	22117-050000	WASHER, 5	1							
8	1	22360-050000	SNAP PIN 5	3							
9	1	22487-050160	PIN, H 5X 16	1							
10	1	26106-060122	BOLT, M6X 12 PLATED	2							

Fig.17. CONTROL DEVICE

(A)=4TNE84-P
(B)=
(C)=

(D)=
(E)=
(F)=

Y00D6410
4TNE84-P

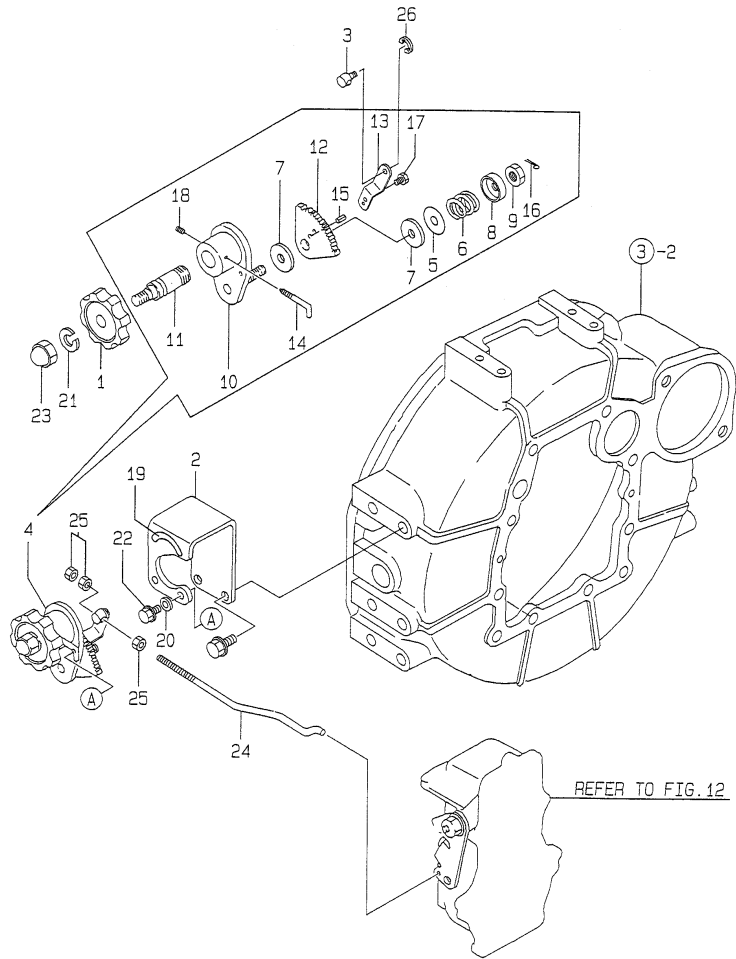

No.	Lev.	Parts No.	Description	Q'ty						I	R
				(A)	(B)	(C)	(D)	(E)	(F)		
1	1	126650-66020	HANDLE, REGULATOR	1							
2	1	119888-66110	BRACKET	1							
3	1	119888-66130	PIVOT	1							
4	1	171048-67010	CONTROLLER ASSY	1							
5	2	171102-66080	WASHER	1							
6	2	104200-66820	SPRING	1							
7	2	104200-66830	PLATE, FRICTION	2							
8	2	104200-66850	WASHER	1							
9	2	104200-66860	NUT	1							
10	2	171085-67100	BRACKET	1							
11	2	171085-67110	SHAFT, DRIVE	1							
12	2	171085-67120	GEAR	1							
13	2	171048-67130	LEVER	1							
14	2	171048-67140	STOPPER	1							
15	2	22351-020006	PIN, SPRING 2.0X 6	1							
16	2	22411-200150	COTTER PIN	1							
17	2	26116-060082	BOLT, M6X 8 PLATED	1							
18	2	26921-050122	SCREW, M5X12	1							
19	1	170064-67210	LABEL, HANDLE	1							
20	1	22117-100000	WASHER, 10	1							
21	1	22217-100000	WASHER, SPRING 10	1							
22	1	26106-060102	BOLT, M6X 10 PLATED	2							
23	1	26657-100002	NUT, CAP M10	1							
24	1	129488-66120	LINK, ENGINE CONTROL	1							
25	1	26756-050002	NUT, LOCK M5	3							
26	1	22272-000050	RING, E- 5	1							

Fig.18. STARTING MOTOR

(A)=4TNE84-P
(B)=
(C)=

(D)=
(E)=
(F)=

Y00D6410
4TNE84-P

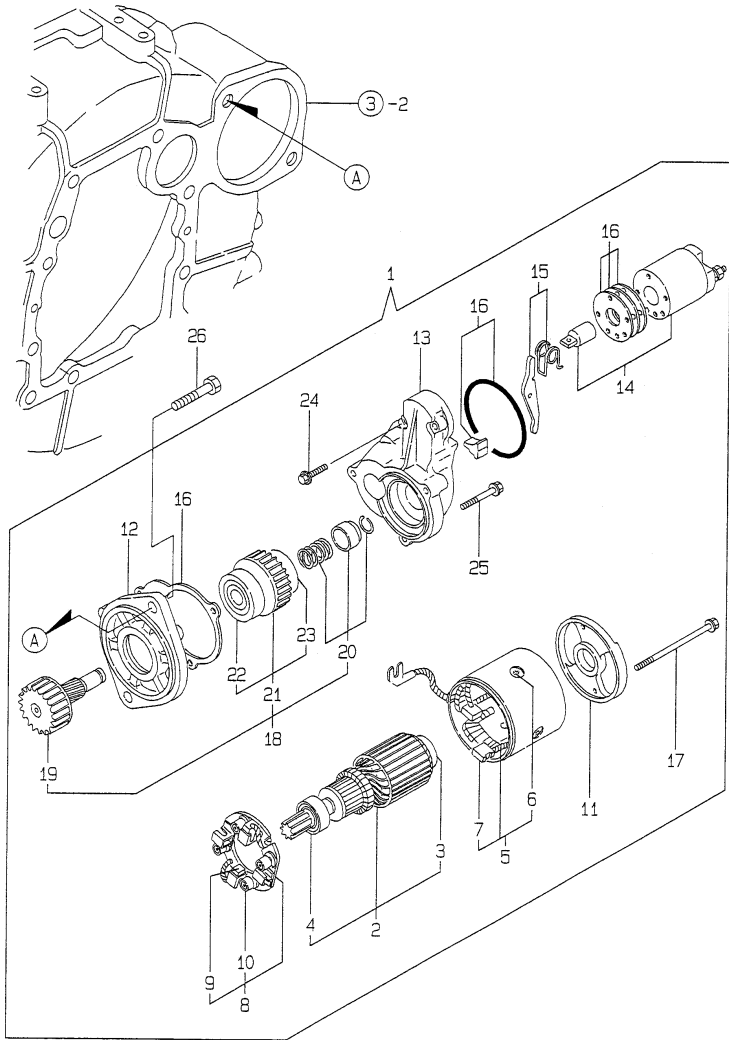

No.	Lev.	Parts No.	Description	Q'ty						I	R
				(A)	(B)	(C)	(D)	(E)	(F)		
1	1	129400-77012	STARTER	1							
2	2	129486-77400	ARMATURE	1							
3	3	171008-77410	BEARING	1							
4	3	171008-77420	BEARING	1							
5	2	129400-77441	COIL ASSY, FIELD	1							
6	3	171008-77450	SCREW	4							
7	3	129486-77460	BRUSH	2							
8	2	129486-77470	HOLDER ASSY, BRUSH	1							
9	3	129486-77460	BRUSH	2							
10	3	129486-77490	SPRING	4							
11	2	129900-77460	COVER	1							
12	2	171008-77510	CASE, GEAR	1							
13	2	129400-77520	HOUSING	1							
14	2	129400-77531	SWITCH ASSY	1							
15	2	171008-77540	LEVER SET	1							
16	2	129400-77571	COVER ASSY, DUST	1							
17	2	129900-77640	BOLT, THROUGH	2							
18	2	171008-77650	PINION ASSY	1							
19	3	171008-77660	SHAFT	1							
20	3	171008-77670	STOPPER SET	1							
21	3	X2114555500	CLUTCH ASSY	1							
22	4	X2114955020	BEARING, BALL	1							
23	4	X2240410100	BEARING, BALL	1							
24	2	26106-060322	BOLT, M6X 32 PLATED	2							
25	2	26106-060402	BOLT, M6X 40 PLATED	3							
26	1	26116-120252	BOLT, M12X 25 PLATED	2							

Fig.19. GENERATOR

(A)=4TNE84-P
(B)=
(C)=

(D)=
(E)=
(F)=

Y00D6410
4TNE84-P

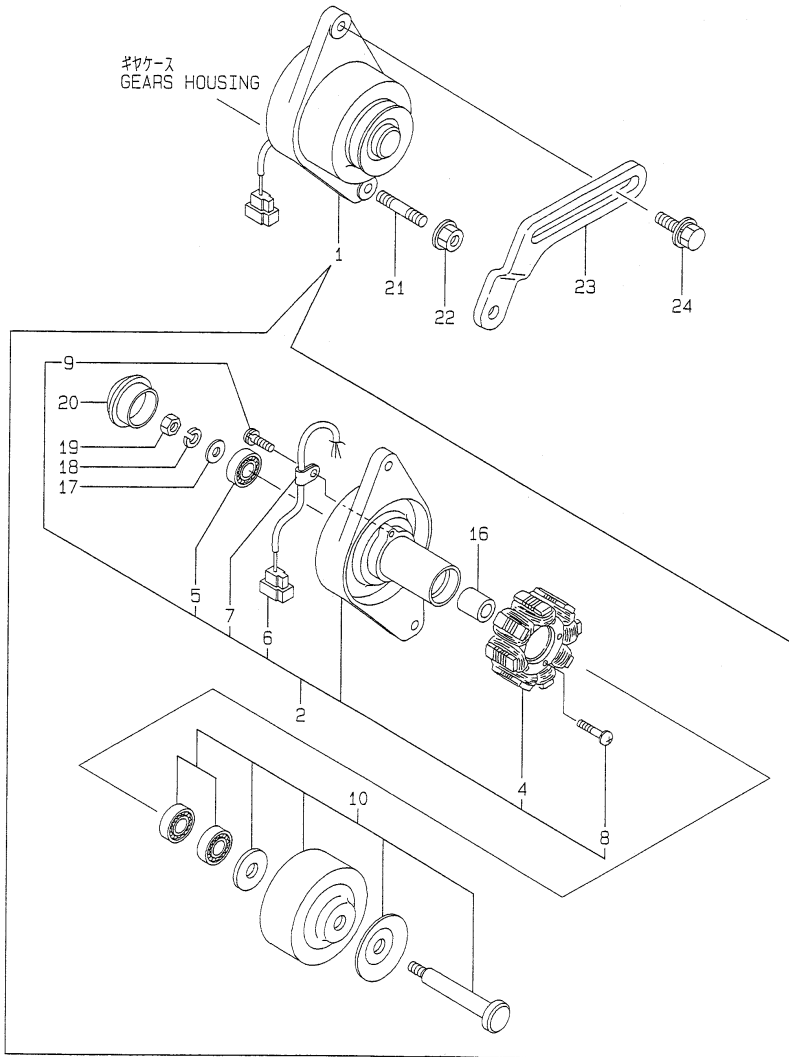

No.	Lev.	Parts No.	Description	Q'ty						I	R
				(A)	(B)	(C)	(D)	(E)	(F)		
1	1	171301-77201	DYNAMO ASSY, 15A	1							
2	2	XM08137	PLATE ASSY	1							
4	3	XM08180	STATOR SET	1							
5	3	XM27436	BEARING, BALL	1							
6	3	XM17878	COUPLER	1							
7	3	XM36410	CLAMP	1							
8	3	26022-040252	SCREW, M4X25	2							
9	3	XYSPS4008	SCREW	1							
10	2	XM82184	FLYWHEEL ASSY	1							
16	2	106383-44720	SPACER	1							
17	2	106383-44730	WASHER	1							
18	2	22212-100000	SPRING WASHER 10	1							
19	2	26716-100002	NUT, M10	1							
20	2	XM61014	CAP	1							
21	1	129795-01900	STUD	1							
22	1	26366-100002	NUT, M10	1							
23	1	129410-77330	ADJUSTER	1							
24	1	26014-080252	BOLT, M8X 25	1							

Fig.20. CLUTCH

(A)=4TNE84-P
(B)=
(C)=

(D)=
(E)=
(F)=

Y00D6410
4TNE84-P

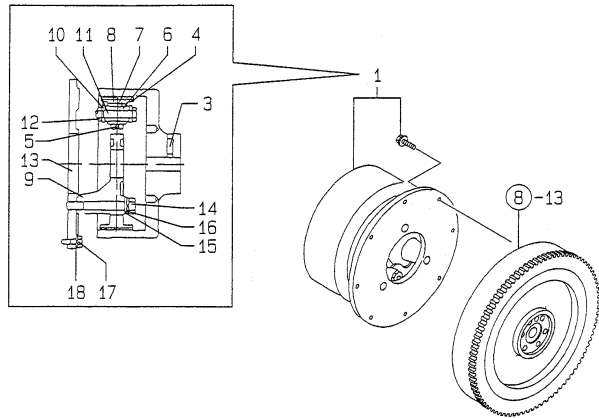

No.	Lev.	Parts No.	Description	Q'ty						I	R
				(A)	(B)	(C)	(D)	(E)	(F)		
1	1	45100-502300	CLUTCH ASSY, FA-73H	1							
3	2	XJC410244	SCREW, M10X20	1							
4	2	X4SC20017	SHOE	3							
5	2	XJC410224	SCREW, M6X6	6							
6	2	X4SC21082	BUSH	6							
7	2	X3SC20051	LINING	3							
8	2	XJC40031	RIVET	3							
9	2	X2SC20211	HOSE	1							
10	2	X4SC20025	PLATE	6							
11	2	XJC40007	BOLT	6							
12	2	XJC40092	NUT	1							
13	2	X3SC21363	ADAPTER	1							
14	2	XJC40019	BOLT, M12X90	3							
15	2	XJC4101410	WASHER	3							
16	2	XJC4101313	WASHER, SPRING	3							
17	2	XJC410597	BOLT, M8X25	8							
18	2	XJC4101311	WASHER, SPRING	8							

Fig.21. INSTRUMENT PANEL

Y00D5410
4TNE84-P

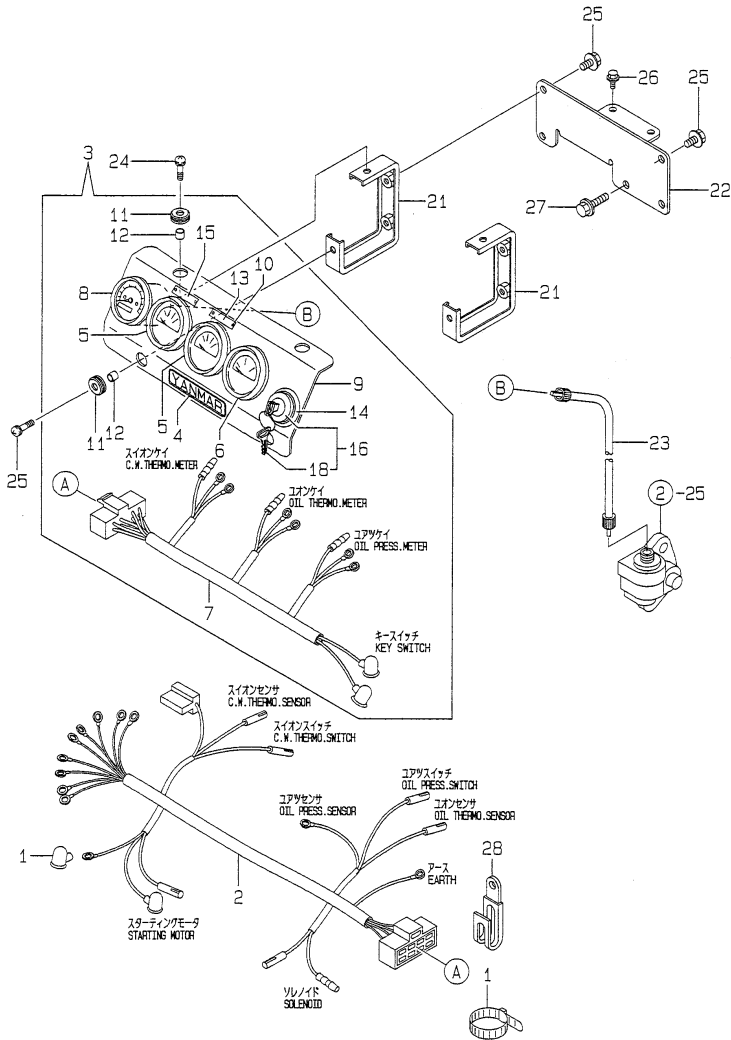

(A)=4TNE84-P
(B)=
(C)=

(D)=
(E)=
(F)=

No.	Lev.	Parts No.	Description	Q'ty						I	R
				(A)	(B)	(C)	(D)	(E)	(F)		
1	1	121750-59890	BAND, 140	1							
2	1	129113-91020	HARNESS, WIRE	1							
3	1	129113-91100	PANEL ASSY	1							
4	2	104507-07190	LABEL, YANMAR	1							
5	2	171010-77850	THERMOSTAT	2							
6	2	171090-91010	GAUGE	1							
7	2	129113-91030	HARNESS, WIRE	1							
8	2	171011-91100	TACHOMETER	1							
9	2	129113-91110	PANEL	1							
10	2	137900-91451	RIVET	4							
11	2	121400-91520	ABSORBER	4							
12	2	121400-91530	SPACER	4							
13	2	132310-91900	LABEL(L.O PRESSURE	1							
14	2	171048-91900	LABEL	1							
15	2	132310-91920	LABEL(C.W PRESSURE	1							
16	2	933110-00100	SWITCH ASSY, STARTER	1							
18	3	933110-00301	KEY ASSY	1							
21	1	119888-91120	SUPPORT	2							
22	1	129413-91130	BRACKET, PANEL	1							
23	1	121400-91140	SHAFT	1							
24	1	26033-060202	SCREW M 6X 20	4							
25	1	26106-080122	BOLT, M8X 12 PLATED	4							
26	1	26106-060122	BOLT, M6X 12 PLATED	2							
27	1	26106-080302	BOLT, M8X 30 PLATED	1							
28	1	194180-51640	CLAMP, HARNESS	1							

Fig.22. SAFETY LABEL

(A)=4TNE84-P
(B)=
(C)=

(D)=
(E)=
(F)=

Y00D6410
4TNE84-P

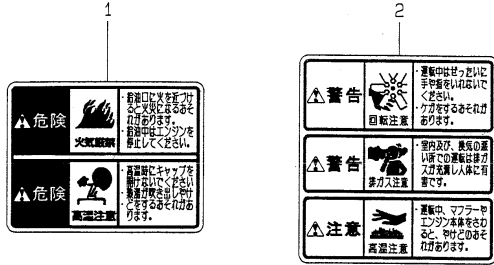

※ 貼付位置は取扱説明書を参照ください

No.	Lev.	Parts No.	Description	Q'ty						I	R
				(A)	(B)	(C)	(D)	(E)	(F)		
1	1	129111-07310	LABEL,NO FIRE	1							
2	1	129111-07320	LABEL,EXH.GAS CAUTN	1							

Fig.23. GASKET SET & TOOL

(A)=4TNE84-P
(B)=
(C)=

(D)=
(E)=
(F)=

Y00D6410
4TNE84-P

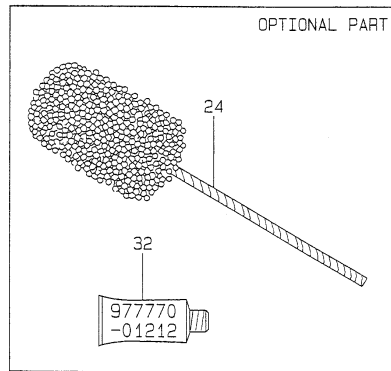
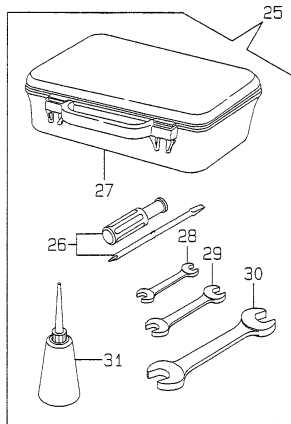
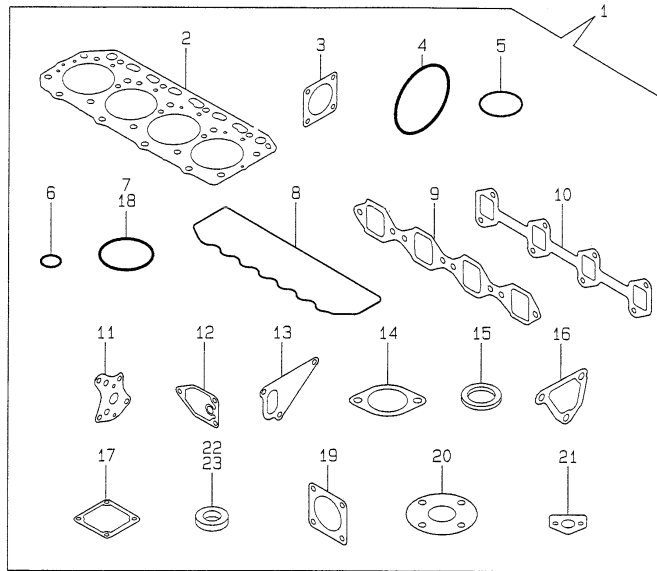

No.	Lev.	Parts No.	Description	Q'ty						I	R
				(A)	(B)	(C)	(D)	(E)	(F)		
1	1	729408-92660	GASKET SET	1							1
2	2	129408-01330	GASKET, HEAD	1							
3	2	124240-01883	GASKET	1							
4	2	121850-51960	O-RING	1							
5	2	24311-000320	O-RING, 1AP32.0	2							
6	2	24311-000120	O-RING, 1AP12.0	3							
7	2	24341-000500	O-RING, 1AS50.0	1							
8	2	129550-11310	GASKET, BONNET	1							
9	2	129550-12111	GASKET, MANIFOLD	1							
10	2	129550-13110	GASKET	1							
11	2	129150-32020	GASKET, PUMP	1							
12	2	129150-35111	GASKET	1							
13	2	129100-42020	GASKET, WATER PUMP	1							
14	2	129795-49551	GASKET	1							
15	2	129150-49811	GASKET, THERMOSTAT	1							
16	2	129100-49840	GASKET	1							
17	2	129150-77511	GASKET	1							
18	2	24341-000250	O-RING, 1AS25.0	1							
19	2	129400-13201	GASKET, SILENCER	1							
20	2	23446-050000	GASKET 50	1							
21	2	129150-35041	GASKET	1							
22	2	129150-49360	GASKET	2							
23	2	124465-44950	GASKET, 16	1							
24	1	129400-92420	HONE	1							1
25	1	721400-92102	BOX ASSY, TOOL	1							
26	2	104200-92350	DRIVER, SCREW	1							
27	2	104200-92600	BOX, TOOL	1							
28	2	28110-100120	SPANNER, 10X12	1							
29	2	28110-140170	SPANNER, 14X17	1							
30	2	28110-190220	SPANNER, 19X22	1							
31	2	28210-000140	OILER	1							
32	1	977770-01212	GASKET, LIQUID	1							1

Remarks

(1) OPTIONAL PART.

Parts No. Index

Parts No.	Fig. No.	Ref. No.
101100-55390	14	31
101147-59810	14	33
101200-55341	14	22
101200-55351	14	23
101200-55360	14	24
101200-55371	14	25
101200-55380	14	26
101200-55490	14	27
101504-55051	14	6
101504-55101	14	7
103854-39140	15	1
104200-11920	3	26
104200-59170	15	13
104200-66820	17	6
104200-66830	17	7
104200-66850	17	8
104200-66860	17	9
104200-92350	23	26
104200-92600	23	27
104300-55250	14	13
104300-55320	14	30
104507-07190	21	4
105302-55040	14	5
105582-59150	15	3
106383-44720	19	16
106383-44730	19	17
112100-55420	14	32
114250-53080	13	5
114250-53120	13	8
114250-53130	13	9
114250-53140	13	10
114250-53210	13	11
114250-53400	13	12
119600-66840	12	74
119620-01750	3	3
119625-11871	4	27
119625-11880	4	25
119625-11900	4	26
119660-61901	12	73
119810-53000	13	2
119865-21600	8	16
119888-01600	3	2
119888-08110	3	23
119888-66110	17	2
119888-66130	17	3
119888-91120	21	21
120130-11860	4	11
121111-21501	8	12
121250-44581	10	25
121250-44901	10	63

Parts No.	Fig. No.	Ref. No.
121400-11340	4	22
121400-44650	10	26
121400-91140	21	23
121400-91520	21	11
121400-91530	21	12
121450-01560	2	6
121456-49160	10	60
121520-34810	9	14
121520-49160	10	59
121550-23200	8	30
121550-49111	10	53
121750-59890	21	1
121850-11860	10	1
121850-21680	8	11
121850-51960	2	13
	23	4
122117-51560	11	48
122710-51090	11	8
123682-44210	10	23
124060-01640	14	2
124160-01751	2	7
	4	46
124160-01910	1	5
	6	6
124160-11360	4	56
124160-39140	9	29
124160-39450	9	28
124240-01871	2	8
124240-01883	2	9
	23	3
124250-49351	9	17
	10	65
124460-11340	4	23
124465-44950	10	64
	23	23
124550-51350	11	30
124550-51370	11	31
124550-59820	9	34
124550-66370	12	56
124574-44761	10	43
124736-07900	4	5
124766-59050	10	61
124950-51190	11	15
126650-66020	17	1
129001-02800	1	15
129001-35300	9	24
129001-42002	10	2
129001-42040	10	17
129002-22081	8	17
129002-22500	8	19

Parts No.	Fig. No.	Ref. No.
129002-22901	8	33
129002-22950	8	35
129100-01580	3	1
	15	15
	8	2
129100-01640	3	16
129100-11100	4	17
129100-11110	4	18
129100-11650	4	37
129100-23910	8	29
129100-25061	7	9
129100-42020	10	14
	23	13
129100-49840	10	16
	23	16
129100-51300	11	25
129100-59951	15	21
129100-61400	12	18
129100-61440	12	78
129100-61501	12	33
129100-61821	12	53
129111-07310	22	1
129111-07320	22	2
129113-01740	3	25
129113-44560	10	24
129113-55100	14	1
129113-55200	14	8
129113-55210	14	12
129113-55800	14	41
129113-55830	14	42
129113-59510	15	6
129113-59600	15	10
129113-91020	21	2
129113-91030	21	7
129113-91100	21	3
129113-91110	21	9
129136-34800	9	39
129150-01200	1	29
129150-02020	1	12
129150-02450	7	4
129150-02870	1	31
129150-02930	1	24
129150-02940	1	34
129150-03020	4	47
129150-03070	4	48
129150-03080	4	49
129150-03090	4	1
129150-03100	2	11
129150-11230	4	38
129150-11280	4	33

Parts No.	Fig. No.	Ref. No.
129150-11370	4	24
129150-11750	4	40
129150-11810	4	13
129150-14101	7	7
129150-14200	7	1
129150-14400	7	2
129150-21200	8	5
129150-23600	8	31
129150-23610	8	39
129150-25101	7	10
129150-25900	7	15
129150-25920	7	13
129150-32020	9	37
	23	11
129150-35041	9	15
	23	21
129150-35042	9	15 -1
129150-35111	9	22
	23	12
129150-35151	9	23
129150-35350	9	25
129150-49080	10	55
129150-49100	10	54
129150-49360	9	18
	10	66
	23	22
129150-49811	10	51
	23	15
129150-59120	13	19
129150-59131	13	22
129150-77511	5	8
	23	17
129150-91400	2	25
129155-11260	4	31
129155-11270	4	32
129155-42350	10	21
129155-49800	10	50
129155-51020	11	4
129155-51050	11	6
129155-51060	11	7
129155-51140	11	12
129155-51180	11	14
129155-51200	11	16
129155-51270	11	23
129155-51280	11	24
	12	2
129155-51320	11	28
129155-51340	11	29
129155-51370	11	32
129155-51380	11	33

Parts No. Index

Parts No.	Fig. No.	Ref. No.
129155-51390	11	34
129155-51410	11	36
129155-51420	11	37
129155-51450	11	38
129155-51521	11	44
129155-51530	11	45
129155-51540	11	46
129155-51550	11	47
129155-51570	11	50
129155-51580	11	51
129155-51591	11	52
129155-51600	11	53
129155-51790	11	76
129155-51930	11	78
129155-51940	11	79
129155-52050	11	92
129155-61050	12	5
129155-61060	12	6
129155-61070	12	7
129155-61120	12	8
129155-61130	12	9
129155-61140	12	10
129155-61341	12	15
129155-61350	12	16
129155-61360	12	17
129155-61430	12	21
129155-61450	12	25
		72
129155-61460	12	26
129155-61470	12	79
129155-61480	12	27
129155-61540	12	51
129155-61810	12	52
129155-61830	12	54
129155-61950	12	55
129156-51910	11	77
129188-08100	3	22
129188-44950	10	28
129188-44960	10	29
129188-44970	10	30
129188-44980	10	31
129202-22300	8	23
129211-49020	10	46
129350-49560	10	48
129400-01520	2	5
129400-01730	3	6
129400-01770	3	8
129400-11350	4	45
129400-12100	5	11
129400-13101	6	1

Parts No.	Fig. No.	Ref. No.
129400-13201	6	6
	23	19
129400-59910	13	24
129400-59920	13	28
129400-59930	13	32
129400-59940	13	36
129400-61801	12	82
129400-77012	18	1
129400-77441	18	5
129400-77520	18	13
129400-77531	18	14
129400-77571	18	16
129400-92420	23	24
129407-11700	4	7
129407-21000	8	1
129407-32000	9	1
129408-01330	1	30
	23	2
129410-65130	16	5
129410-77330	19	23
129411-13300	6	7
129413-44940	10	27
129413-91130	21	22
129436-35070	9	16 -1
129436-35091	9	16
129470-12210	5	1
129470-51040	11	5
129470-51101	11	9
129477-61710	12	81
129486-01670	3	19
129486-77400	18	2
129486-77460	18	7
		9
129486-77470	18	8
129486-77490	18	10
129488-21590	8	13
129488-66120	17	24
129489-59550	15	15
129491-52100	11	93
129491-59540	15	14
129500-11240	4	30
129500-61650	12	80
129550-11290	4	34
129550-11310	4	52
	23	8
129550-12111	5	12
	23	9
129550-13110	6	2
	23	10
129550-21650	8	9

Parts No.	Fig. No.	Ref. No.
129550-39450	9	30
129555-51400	11	35
129555-51500	11	43
129555-51700	11	72
129555-51710	11	73
129555-51750	11	74
129555-51760	11	75
129604-07900	4	5 -1
129660-61491	12	32
129688-01780	3	8 -1
129795-01780	3	18
129795-01800	2	4
129795-01900	19	21
129795-01950	2	10
129795-02411	1	27
129795-11120	4	19
129795-11180	4	20
129795-12501	5	4
129795-12520	5	5
129795-12530	5	6
129795-12540	5	7
129795-21661	8	10
129795-49551	10	49
	23	14
129900-07900	4	5 -2
129900-77460	18	11
129900-77640	18	17
132310-91900	21	13
132310-91920	21	15
137900-91451	21	10
144626-91560	9	40
170064-67210	17	19
171008-77410	18	3
171008-77420	18	4
171008-77450	18	6
171008-77510	18	12
171008-77540	18	15
171008-77650	18	18
171008-77660	18	19
171008-77670	18	20
171010-65100	16	1
171010-77850	21	5
171011-91100	21	8
171031-01640	3	9
171048-55850	14	43
171048-67010	17	4
171048-67130	17	13
171048-67140	17	14
171048-91900	21	14
171049-59010	15	2

Parts No.	Fig. No.	Ref. No.
171051-01921	1	7
171085-67100	17	10
171085-67110	17	11
171085-67120	17	12
171090-91010	21	6
171102-66080	17	5
171301-49010	10	45
171301-77201	19	1
171335-65110	16	2
171335-65120	16	3
171335-77951	16	6
171340-44740	10	42
171375-35100	9	21
171375-39601	9	19
171440-44500	10	22
171488-61200	12	11
174307-51170	11	13
174307-51560	11	49
174307-51700	12	34
194180-51640	21	28
194990-22050	6	3
22117-040000	12	57
22117-050000	16	7
22117-080000	14	44
22117-100000	17	20
22137-080000	10	32
22190-060002	12	70
		75
22190-080002	2	12
		23
	9	35
22190-080003	15	12
22190-100002	12	58
22190-120002	12	71
	15	4
22190-160002	11	80
22212-100000	19	18
22217-050000	11	81
22217-060000	11	82
	14	29
		34
22217-100000	10	33
	17	21
22217-120000	7	16
22252-000260	8	24
22272-000040	12	59
22272-000050	17	26
22287-120000	12	60
22351-020006	17	15
22351-030016	12	61

Parts No. Index

Parts No.	Fig. No.	Ref. No.
22351-040010	8	8
22351-050010	11	83
22351-060012	4	28
22360-050000	16	8
22372-040000	12	62
22411-200150	17	16
22487-050160	16	9
22512-070140	7	8
	8	6
23000-060000	5	9
23010-038000	10	47
23061-070330	14	35
23217-050000	6	12
23414-060000	15	5
23414-080000	14	36
23414-080012	15	11
23414-100000	9	36
23414-160000	14	37
23414-170000	6	8
23414-220000	3	27
23446-050000	6	13
	23	20
23831-100000	14	38
23871-010000	1	8
	5	3
23871-030000	1	28
	5	13
	10	12
23887-100002	12	63
23894-030002	6	9
24101-063034	11	84
24311-000120	4	57
	23	6
24311-000140	14	39
24311-000160	2	14
	9	26
24311-000320	2	15
	4	53
	23	5
24311-240100	12	64
24321-000300	10	18
24341-000160	11	85
24341-000240	2	27
24341-000250	3	11
	23	18
24341-000500	4	54
	23	7
25132-003800	10	20
26014-060252	10	44
26014-080252	19	24

Parts No.	Fig. No.	Ref. No.
26022-040252	19	8
26022-050102	11	86
	12	65
26022-060162	11	87
26023-050102	12	66
26033-060202	21	24
26106-060102	12	76
	17	22
26106-060122	16	10
	21	26
26106-060142	14	45
26106-060162	2	28
26106-060202	12	67
26106-060322	18	24
26106-060402	18	25
26106-080122	2	16
	10	34
	21	25
26106-080142	4	6
	7	18
	14	46
	16	4
26106-080162	2	17
		24
	3	12
	4	55
	5	10
	10	19
		35
		62
26106-080202	2	18
	9	27
	10	36
		52
26106-080252	3	13
	4	43
	10	37
26106-080302	21	27
26106-080352	3	20
	5	14
	9	20
26106-080452	2	19
	3	14
		14 -1
	6	10
	7	14
26106-080502	3	28
	4	44
26106-080552	2	20
	9	20 -1

Parts No.	Fig. No.	Ref. No.
26106-080602	10	15
26106-080802	6	4
26106-080852	2	21
26106-080952	6	11
26106-100182	14	47
26106-100202	3	24
26106-100302	10	38
26116-050302	11	88
26116-060082	17	17
26116-120252	18	26
26116-120502	6	14
26206-100252	3	4
26206-100302	3	5
26216-060182	14	4
26216-060202	4	15
26216-080802	6	5
26226-080182	4	41
26366-060002	4	29
	14	40
26366-080002	2	22
	10	39
	12	83
26366-100002	19	22
26450-060252	9	38
26657-100002	17	23
26687-120002	12	84
26716-060002	11	89
26716-100002	10	40
	19	19
26716-120002	6	15
	7	17
26756-050002	17	25
26756-060002	12	68
		77
26756-080002	4	42
26756-100002	10	41
26776-120002	12	69
26921-050122	17	18
27231-500000	1	9
27241-120000	1	10
27241-300000	1	11
27241-400000	4	16
27310-080001	4	21
28110-100120	23	28
28110-140170	23	29
28110-190220	23	30
28210-000140	23	31
43100-552900	6	16
43720-500120	6	17
45100-502300	20	1

Parts No.	Fig. No.	Ref. No.
704800-55310	14	18
719810-01500	2	1
719810-53100	13	1
721400-92102	23	25
729402-14580	7	3
729402-23100	8	25
729408-01560	1	1
729408-51320	11	1
729408-92660	23	1
933110-00100	21	16
933110-00301	21	18
977770-01212	2	29
	3	21
	23	32
X2114555500	18	21
X2114955020	18	22
X2240410100	18	23
X2SC20211	20	9
X3SC20051	20	7
X3SC21363	20	13
X4SC20017	20	4
X4SC20025	20	10
X4SC21082	20	6
XJC40007	20	11
XJC40019	20	14
XJC40031	20	8
XJC40092	20	12
XJC4101311	20	18
XJC4101313	20	16
XJC4101410	20	15
XJC410224	20	5
XJC410244	20	3
XJC410597	20	17
XM08137	19	2
XM08180	19	4
XM17878	19	6
XM27436	19	5
XM36410	19	7
XM61014	19	20
XM82184	19	10
XYSPS4008	19	9