

0CD10-M48900EN

PREFACE

1. This Parts Catalog is the 1st edition of EP1700-3100 Diesel Engine for HOKUETSU.

Pub. No. : 000Y00D4890
Published : November, 1993

2. Model name

Engine model	Vehicle		Vehicle made by
	Products	Model name	
EP1700-3100	GENERATOR	—	HOKUETSU

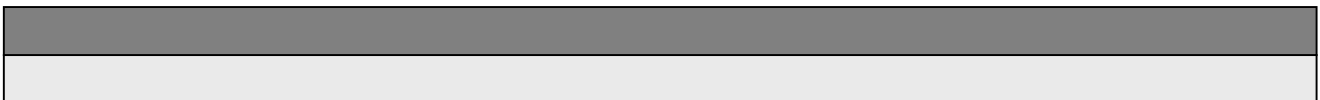

Directions for the Parts Catalog.

1. The parts stipulated in this Parts Catalog are not necessarily standard equipped parts.
2. Parts may change without prior notice.
3. The following is an example of the Parts Catalog format.

REF.	LEV.	PARTS NO.	DESCRIPTION	Q'TY						I	R
				(A)	(B)	(C)	(D)	(E)	(F)		
1	1	729595-51390	FUEL INJECTION PUMP	1	1	1	1	1			1
1-1	1	729595-51391	FUEL INJECTION PUMP	1	1	1	1	1		N	1
		(A=E00185) (B=E00200)									
3	2	26022-060162	SCREW M 6X 16	9	9	9	9	9			
3-1	2	26022-060162	SCREW M 6X 16	4	4	4	4	4		K	
		(A=E00156) (B=E00156) (C=E00156) (D=E00156) (E=E00156)									
4	2	129470-51040	CAMSHAFT	1	1	1	1	1			
5	2	122710-51050	BEARING, ROLLER	2	2	2	2	2			
6	2	129470-51060	RETAINER	1	1	1	1	1			

Remarks
(1) BOOST COMPEMSATOR TYPE. OPTIONAL PART, TO E00155,(4JH-DT, 4JH-DTZ

① Ref. No.

The Ref. No. listed may not be in accordance with the illustration Ref. No.

(Ex.) Illustration No.

List Ref No.

1

1

(Before change)

1-1

(After change)

For interchangeable symbols N, R and K, illustrations for new parts may be abbreviated.

② Lev. (Level)

Level indication

The numbers below indicate the level of relativity towards the main part.

1 ----- Main parts (Assembly parts)

2 ----- Sub component included in " 1 ".

3 ----- Sub component included in " 2 ".

Note) Parts that are not for sale are partially illustrated but not listed.

③ Interchangeability Mark

When a part change takes place, one of the following interchangeability symbols is indicated beside the part.

Symbol	Interchangeability	Contents note
N	Old $\begin{matrix} \leftarrow \text{Yes} \\ \text{No} \rightarrow \end{matrix}$ New	New Part is interchangeable for Old Part but Old Part is not interchangeable for New Part.
Q	Old $\begin{matrix} \leftarrow \text{No} \\ \text{Yes} \rightarrow \end{matrix}$ New	New Part is not interchangeable for Old Part but Old Part is interchangeable for New Part.
R	Old $\begin{matrix} \leftarrow \text{Yes} \\ \text{Yes} \rightarrow \end{matrix}$ New	New/ Old Parts are both interchangeable.
S	Old $\begin{matrix} \leftarrow \text{No} \\ \text{No} \rightarrow \end{matrix}$ New	New/ Old Parts are both not interchangeable.
W		Part newly added.
Z		Part discontinued.
F		Not interchangeable by a single part but interchangeable together with related parts.
K		Changes only for used parts quantities.

④ Effective Machine No.

When a part changes, the effective Machine No. will be indicated in the (A)-(F) column.

Product Symbol	Product No.	Product Symbol	Product No.
C	Clutch No. Compressor No.	F	Machine No. (Agricultural Equip.)
D	Drive No.	M	Machine No.
E	Engine No.		

Note 1) A date may follow the symbol. (Ex.) 1996.01

Note 2) "XXXXX" and "ZZZZZ" are for parts that could not be predicted or for engine models that could not be identified.

Note 3) (A=E00185) is the E (Engine Serial Number) for the column (A) model (in this case 4JH-DT) after the parts design change.

⑤ Remarks Mark

Figures or alphabets (symbols) are entered in the remarks column.

The comments (remarks) on parts that are indicated at the bottom of the illustration are the same symbols as those stated above.

Contents

Fig. No. Fig. Name

EP1700-3100S

1. CYLINDER BLOCK
2. CYLINDER HEAD & BONNET
3. AIR CLEANER
4. MUFFLER
5. CRANKSHAFT, PISTON & CAMSHAFT
6. LUB. OIL PUMP & GOVERNOR
7. COOLING & STARTING DEVICE
8. FUEL INJECTION PUMP
9. FUEL TANK & FUEL LINE
10. STARTING MOTOR & DYNAMO
11. TOOL,LABEL & GASKET SET
12. FRAME & BATTERY
13. SOUND-PROOF CASE
14. GENERATOR
15. PANEL(EP1700/2000/2700/3100)
16. PANEL(EP1700/2000/2700/3100S)

Fig. No. Fig. Name

Fig.1. CYLINDER BLOCK

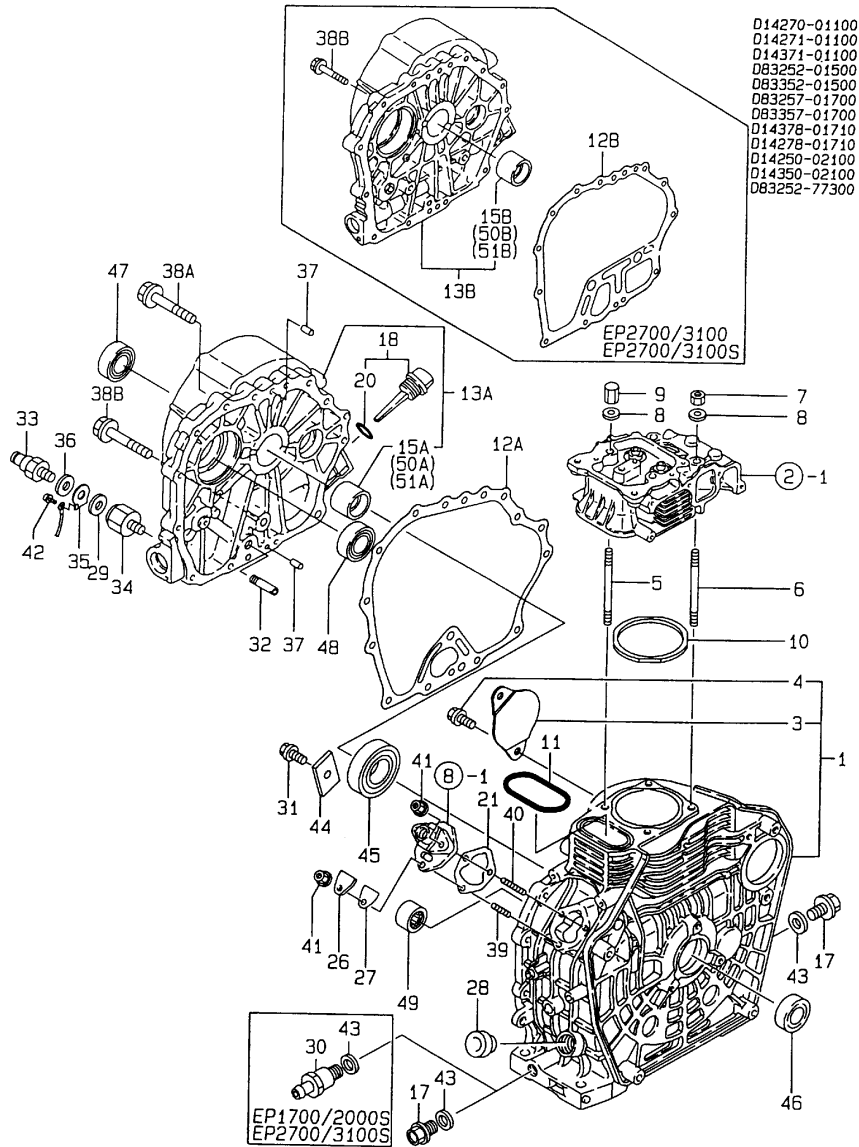

(A)=EP1700/2000
 (B)=EP1700/2000S
 (C)=EP2700/3100

(D)=EP2700/3100S
 (E)=
 (F)=

No.	Lev.	Parts No.	Description	Q'ty						I	R
				(A)	(B)	(C)	(D)	(E)	(F)		
1A	1	714271-01560	BLOCK ASSY, CYLINDER	1	1						
1B	1	714371-01560	BLOCK ASSY, CYLINDER								
3	2	114350-01700	COVER	1	1	1	1				
4	2	26106-100122	BOLT, M10X 12 PLATED	2	2	2	2				
5A	1	114250-01200	BOLT, HEAD	2	2						
5B	1	114350-01200	BOLT, HEAD			2	2				
6A	1	114250-01210	BOLT, HEAD	2	2						
6B	1	114350-01210	BOLT, HEAD			2	2				
7A	1	114250-01220	NUT, CYLINDER HEAD	2	2						
7B	1	114350-01220	NUT, CYLINDER HEAD			2	2				
8A	1	124950-01250	WASHER	4	4						
8B	1	105225-01240	WASHER			4	4				
9A	1	114250-01250	NUT, CAP	2	2						
9B	1	114350-01250	NUT, CYLINDER HEAD			2	2				
10A	1	114250-01340	GASKET, HEAD	1	1						
10B	1	114350-01340	GASKET, HEAD				1	1			
11A	1	114250-01380	O-RING	1	1						
11B	1	114350-01380	O-RING			1	1				
12A	1	114250-01412	GASKET, CRANK CASE	1	1						
12B	1	114350-01412	GASKET, CRANK CASE				1	1			
13A	1	183250-01450	COVER, CRANK CASE	1	1						
13B	1	183350-01450	COVER, CRANK CASE				1	1			
15A	2	114250-02100	BEARING, MAIN	1	1						1
15B	2	114350-02100	BEARING, MAIN				1	1			1
17	1	105425-01690	PLUG, 16	2	1	2	1				
18A	1	160710-01760	CAP ASSY, L82	1	1						
18B	1	160910-01740	CAP ASSY				1	1			
20	2	24311-000180	O-RING, 1AP18.0	1	1	1	1				
21	1	114250-01800	SHIM SET	1	1	1	1				
26	1	114250-01830	COVER	1	1	1	1				
27	1	114250-01840	GASKET	1	1	1	1				
28	1	160110-01870	PLUG, RUBBER	1	1	1	1				
29	1	183366-08290	WASHER	1	1	1	1				
30	1	183366-08351	NIPPLE, DRAIN			1					
31	1	26106-080122	BOLT, M8X 12 PLATED	1	1	1	1				
32	1	114250-35150	PIPE, OIL INLET	1	1	1	1				
33	1	183250-39450	SWITCH, 1.0KG	1	1	1	1				
34	1	183366-39460	JOINT	1	1	1	1				
35	1	171022-39470	TERMINAL, EARTH	1	1	1	1				
36	1	22117-100000	WASHER, 10	1	1	1	1				
37	1	22312-080120	PIN, PARALLEL M8X12	2	2	2	2				
38A	1	26106-060252	BOLT, M6X 25 PLATED	14	14						
38B	1	26106-080352	BOLT, M8X 35 PLATED	1	1	15	15				
39	1	26226-060182	STUD, M6X 18	1	1	1	1				
40	1	26226-060222	STUD, M6X 22	2	2	2	2				
41	1	26366-060002	NUT, M6	3	3	3	3				
42	1	26557-040082	SCREW, M4X 8	1	1	1	1				
43A	1	22190-160002	WASHER, SEAL 16	2		2					
43B	1	43400-500490	SEAL WASHER 16S		2		2				
44	1	114250-02030	RETAINER, BEARING	1	1	1	1				
45A	1	114250-02113	BEARING, HR6306G3C3	1	1						

Remarks

- (1) ONLY FOR REPAIR.
- (2) UNDER-SIZE(U.S=0.25)PART.
- (3) UNDER-SIZE(U.S=0.50)PART.

Fig.2. CYLINDER HEAD & BONNET

(A)=EP1700/2000
 (B)=EP1700/2000S
 (C)=EP2700/3100

(D)=EP2700/3100S
 (E)=
 (F)=

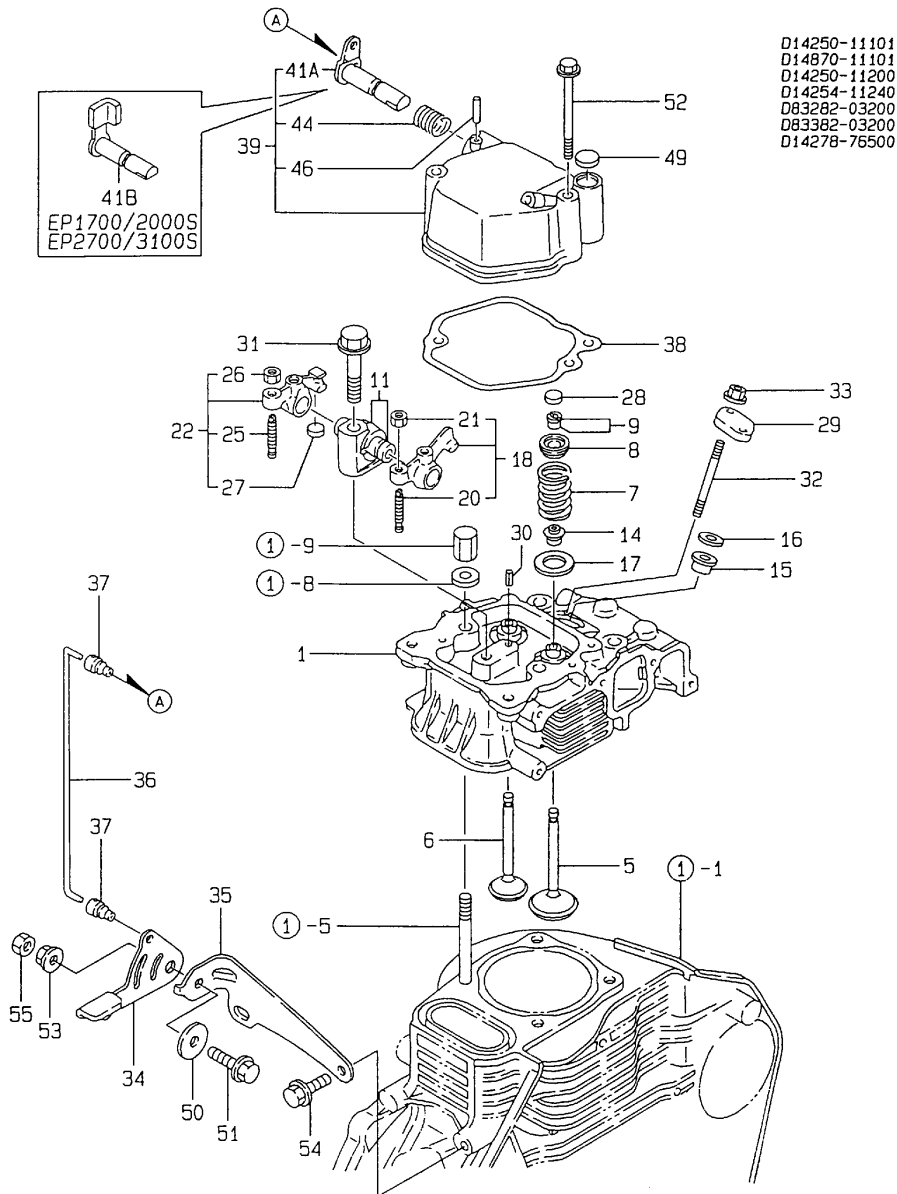

No.	Lev.	Parts No.	Description	Q'ty						I	R
				(A)	(B)	(C)	(D)	(E)	(F)		
1A	1	114250-11020	HEAD ASSY, CYLINDER	1	1						
1B	1	114870-11020	HEAD ASSY, CYLINDER				1	1			
5A	1	114250-11101	VALVE, INTAKE	1	1						
5B	1	114350-11101	VALVE, INTAKE				1	1			
6A	1	114250-11113	VALVE, EXHAUST	1	1						
6B	1	114350-11113	VALVE, EXHAUST				1	1			
7A	1	114250-11120	SPRING, VALVE	2	2						
7B	1	114350-11120	SPRING, VALVE				2	2			
8A	1	114250-11180	RETAINER, SPRING	2	2						
8B	1	101158-11180	RETAINER, SPRING				2	2			
9A	1	714250-11570	COTTER ASSY	2	2						
9B	1	27310-060001	COTTER, 6				2	2			
11	1	114250-11290	SUPPORT, ROCKER ARM	1	1	1	1				
14A	1	114250-11340	SEAL, VALVE STEM	2	2						
14B	1	114350-11340	SEAL, VALVE STEM				2	2			
15	1	114250-11460	GASKET, NOZZLE	1	1	1	1				
16	1	114350-11470	SPACER, NOZZLE	1	1	1	1				
17	1	114250-11600	WASHER	2	2	2	2				
18	1	114250-11651	ARM, ROCKER	1	1	1	1	1			
20	2	114250-11240	SCREW, VALVE ADJUST	1	1	1	1				
21	2	26756-060002	NUT, LOCK M6	1	1	1	1				
22A	1	714270-11660	ARM ASSY, ROCKER	1	1						
22B	1	714370-11660	ARM ASSY, ROCKER				1	1			
25	2	114250-11240	SCREW, VALVE ADJUST	1	1	1	1				
26	2	26756-060002	NUT, LOCK M6	1	1	1	1				
27A	2	119260-11370	CAP, VALVE	1	1						
27B	2	105010-11490	CAP, VALVE				1	1			
28A	1	119260-11370	CAP, VALVE	1	1						
28B	1	105010-11490	CAP, VALVE				1	1			
29	1	114250-11900	RETAINER, NOZZLE	1	1	1	1				
30	1	22351-040008	PIN, SPRING 4.0X 8	1	1	1	1				
31	1	26106-080452	BOLT, M8X 45 PLATED	1	1	1	1				
32	1	26226-060502	STUD, M6X 50	2	2	2	2				
33	1	26366-060002	NUT, M6	2	2	2	2				
34	1	183250-03410	LEVER, DECOMPRESSION	1		1					
35	1	183250-03450	BRACKET, LEVER	1		1					
36A	1	183250-03510	LINK	1							
36B	1	183350-03510	LINK				1				
37	1	183250-03550	JOINT	2		2					
38	1	114250-11310	GASKET, BONNET	1	1	1	1				
39A	1	183250-11951	BONNET ASSY, HEAD	1		1					
39B	1	114250-11951	BONNET ASSY, HEAD				1		1		
41A	2	183250-03601	SHAFT, DECOMPRESSION	1		1					
41B	2	114250-03591	LEVER ASSY		1		1				
44	2	114250-03640	SPRING, DECOMPRESSION	1	1	1	1				
46	2	22312-030160	PIN, PARALLEL M3X16	1	1	1	1				
49	1	129100-61850	PLUG, 12			1		1			
50	1	160670-66350	COLLAR	1		1					
51	1	26106-060202	BOLT, M6X 20 PLATED	1		1					
52	1	26106-060552	BOLT, M6X 55 PLATED	2	2	2	2				
53	1	26366-060002	NUT, M6	1		1					

Fig.2. CYLINDER HEAD & BONNET

(A)=EP1700/2000
 (B)=EP1700/2000S
 (C)=EP2700/3100

(D)=EP2700/3100S
 (E)=
 (F)=

No.	Lev.	Parts No.	Description	Q'ty						I	R
				(A)	(B)	(C)	(D)	(E)	(F)		
54	1	26476-060142	SCREW, TAPPING M6X14	2		2					
55	1	26756-060002	NUT, LOCK M6	1		1					

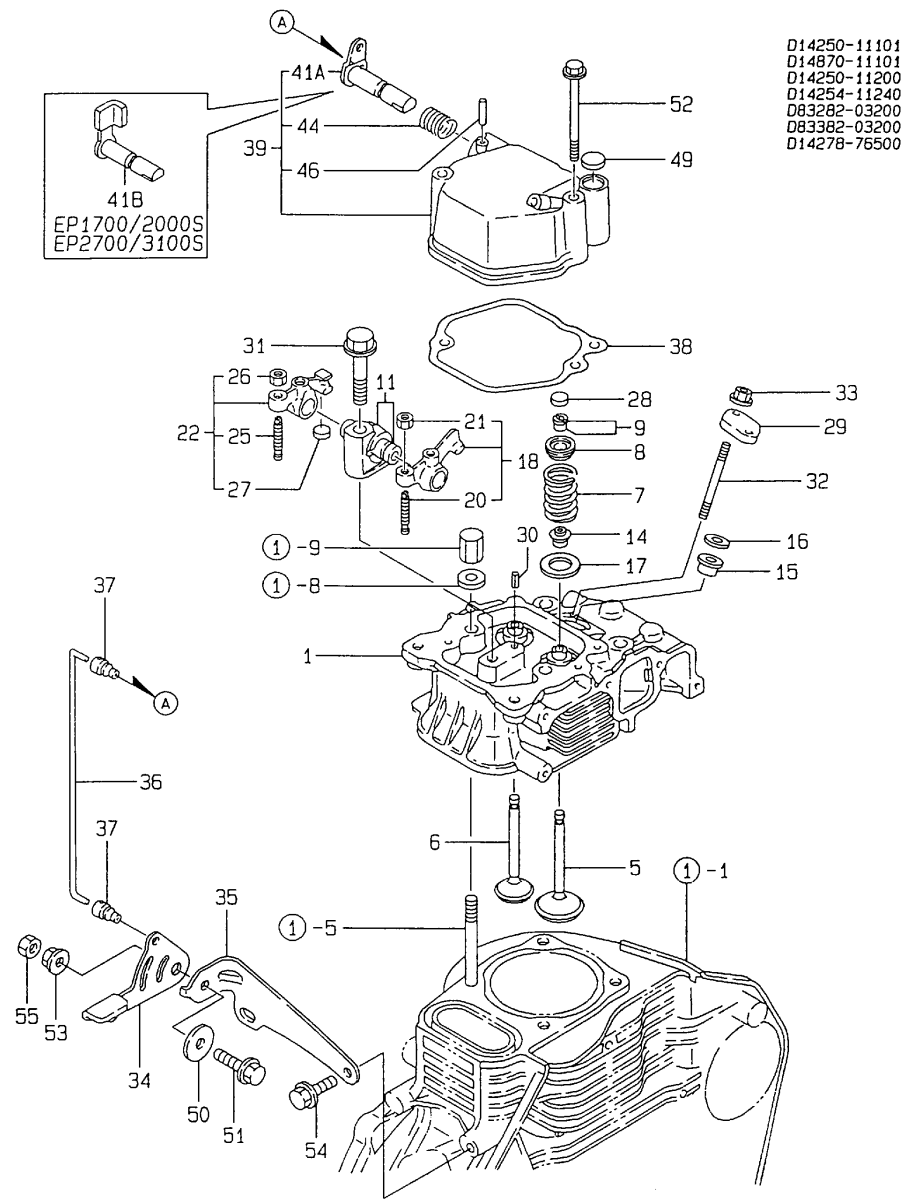

Fig.3. AIR CLEANER

(A)=EP1700/2000
 (B)=EP1700/2000S
 (C)=EP2700/3100

(D)=EP2700/3100S
 (E)=
 (F)=

No.	Lev.	Parts No.	Description	Q'ty						I	R
				(A)	(B)	(C)	(D)	(E)	(F)		
1A	1	114250-12010	PIPE, AIR INTAKE	1	1						
1B	1	114350-12011	PIPE, AIR INTAKE				1	1			
2A	1	114250-12200	GASKET	1	1						
2B	1	114350-12201	GASKET				1	1			
3	1	114250-12210	GASKET, AIR CLEANER	1	1	1	1	1	1		
4	1	114650-12350	GROMMET						1		
5A	1	714250-12560	CLEANER ASSY, AIR	1		1					
5B	1	783366-12560	CLEANER ASSY, AIR		1			1			
7	2	114250-12520	COVER, AIR CLEANER	1	1	1	1	1	1		
8A	2	114250-12530	CASE ASSY, CLEANER	1		1					
8B	2	183366-12530	CASE ASSY			1		1			
9	2	114250-12560	WASHER, SEAL M6	1	1	1	1	1	1		
10	2	114250-12580	ELEMENT	1	1	1	1	1	1		
11	2	114250-12550	NUT, WING M6	1	1	1	1	1	1		
12	1	183366-12590	HOSE, CLEANER		1		1				
13	1	26106-060252	BOLT, M6X 25 PLATED	1	1	2	2	2	2		
14	1	26226-060142	STUD, M6X 14	1	1	1	1	1	1		
15	1	26366-060002	NUT, M6	3	3	3	3	3	3		
16	1	26226-060552	STUD, M6X 55	2	2	2	2	2	2		

D14270-12100
 D14270-12110
 D14270-12500
 D14370-12500
 D14370-12510
 D14270-12600
 D14370-12600
 D14270-12800

EP1700/2000S
 EP2700/3100S

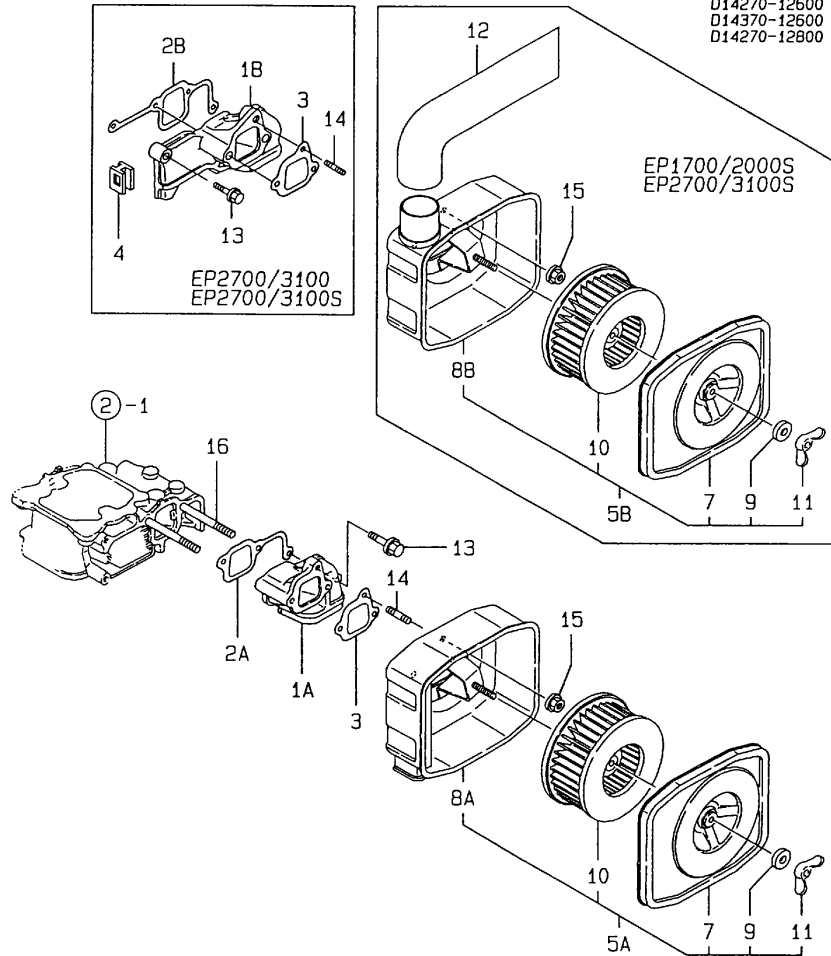
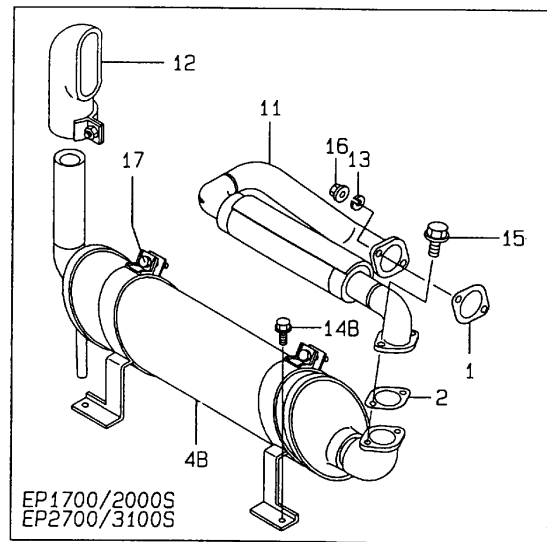
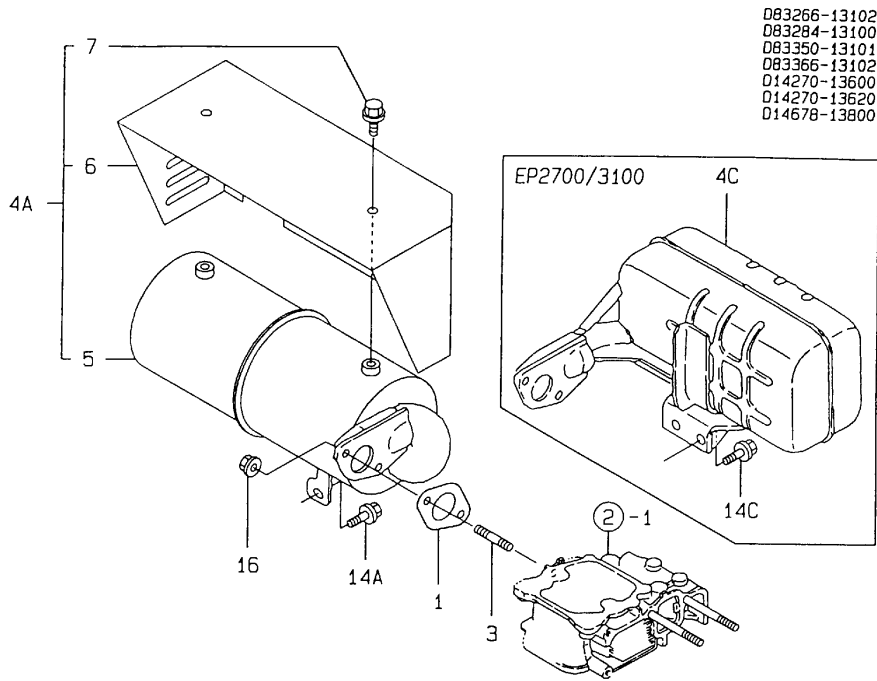

Fig.4. MUFFLER



No.	Lev.	Parts No.	Description	Q'ty						I	R
				(A)	(B)	(C)	(D)	(E)	(F)		
1	1	114250-13200	GASKET, MUFFLER	1	1	1	1				
2	1	183671-13210	GASKET		1		1				
3	1	26216-080182	STUD, M8X 18		2	2	2				
4A	1	183284-13050	MUFFLER ASSY	1							
4B	1	183366-13300	MUFFLER ASSY		1		1				
4C	1	183350-13512	MUFFLER ASSY				1				
5	2	183284-13500	MUFFLER	1							
6	2	183284-13550	COVER	1							
7	2	114252-13950	BOLT, M6X8	4							
11A	1	183266-13601	PIPE		1						
11B	1	183366-13601	PIPE				1				
12	1	114658-13800	PIPE		1		1				
13	1	22213-080000	WASHER, SPRING 8		2		2				
14A	1	26106-080162	BOLT, M8X 16 PLATED	1							
14B	1	26014-060142	BOLT, M6X 14		4		4				
14C	1	26106-060162	BOLT, M6X 16 PLATED				2				
15	1	26013-080302	BOLT, M8X 30		2		2				
16	1	26366-080002	NUT, M8	2	2	2	2				
17	1	26106-060202	BOLT, M6X 20 PLATED		2		2				

Fig.5. CRANKSHAFT, PISTON & CAMSHAFT

(A)=EP1700/2000
 (B)=EP1700/2000S
 (C)=EP2700/3100

(D)=EP2700/3100S
 (E)=
 (F)=

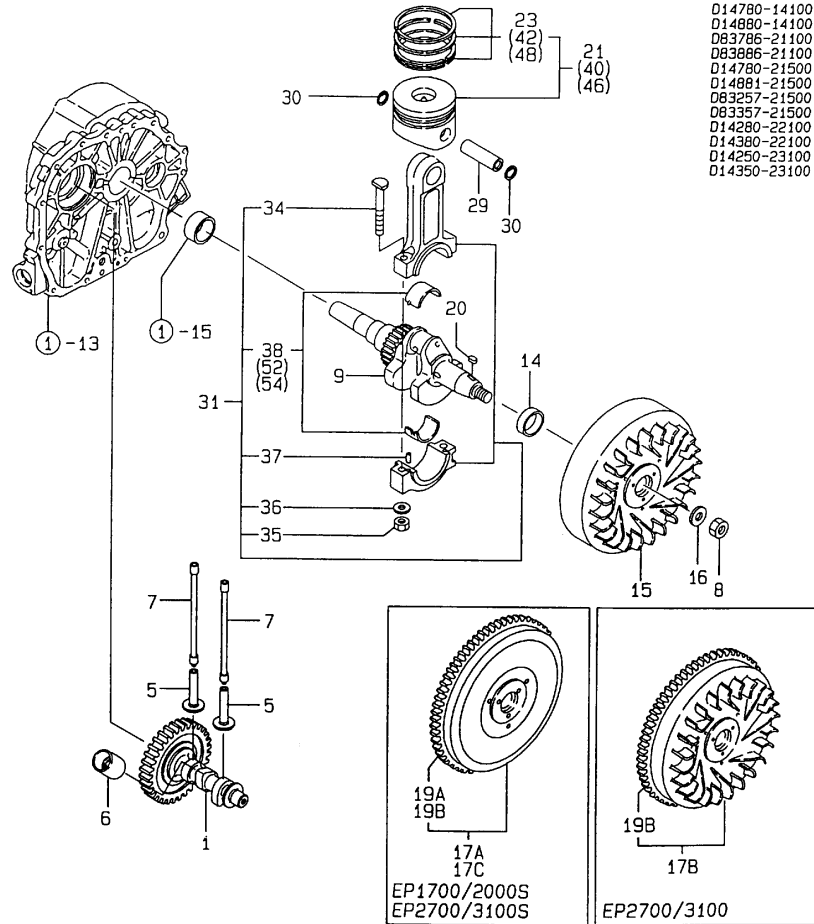

No.	Lev.	Parts No.	Description	Qty						I	R
				(A)	(B)	(C)	(D)	(E)	(F)		
1A	1	714780-14580	CAMSHAFT ASSY	1	1						
1A-1	1	714780-14581	CAMSHAFT ASSY, D	1	1						R
				(A=EZZZZZ)		(B=EZZZZZ)					
1B	1	714880-14580	CAMSHAFT ASSY			1	1				
5	1	114250-14200	TAPPET	2	2	2	2				
6	1	114250-14260	TAPPET	1	1	1	1				
7A	1	114250-14450	ROD ASSY, PUSH	2	2						
7B	1	114350-14450	ROD ASSY, PUSH			2	2				
8	1	103854-01221	NUT, CYLINDER HEAD	1	1	1	1				
9A	1	783292-21700	CRANKSHAFT ASSY	1	1						
9B	1	783392-21700	CRANKSHAFT ASSY				1	1			
14A	1	183250-21350	SPACER, CRANKSHAFT	1	1						
14B	1	183350-21350	SPACER, CRANKSHAFT				1	1			
15	1	114780-21400	FLYWHEEL	1							
16	1	114250-21550	WASHER	1	1	1	1				
17A	1	183266-21590	FLYWHEEL ASSY		1						
17B	1	114881-21590	FLYWHEEL ASSY				1				
17C	1	183366-21590	FLYWHEEL ASSY					1			
19A	2	114262-21600	GEAR, RING		1						
19B	2	114362-21600	GEAR, RING				1	1			
20	1	22512-040120	KEY, 4X 12	1	1	1	1				
21A	1	714280-22720	PISTON ASSY, D	1	1						
21B	1	714380-22720	PISTON ASSY, D				1	1			
23A	2	714250-22502	RING SET, PISTON	1	1						
23B	2	714350-22502	RING SET, PISTON				1	1			
29A	1	114250-22302	PIN, PISTON D=19	1	1						
29B	1	114350-22301	PIN, PISTON D=21					1	1		
30A	1	22252-000190	RING, 19	2	2						
30B	1	22252-000210	RING, 21				2	2			
31A	1	714250-23703	ROD ASSY, CONNECTING	1	1						
31B	1	714350-23704	ROD ASSY, CONNECTING				1	1			
34	2	114250-23200	BOLT, CONNECTING ROD	2	2	2	2				
35	2	114250-23220	NUT	2	2	2	2				
36	2	114250-23250	WASHER	2	2	2	2				
37	2	22312-030080	PIN, PARALLEL M3X 8	2	2	2	2				
38A	2	714250-23600	BEARING, CRANK PIN	1	1						
38B	2	714350-23600	BEARING, CRANK PIN				1	1			
40A	1	714280-22620	PISTON ASSY, 0.25 OS	1	1						1
40B	1	714380-22620	PISTON ASSY, 0.25 OS				1	1			1
42A	2	714250-22542	RING SET, 0.25 OS	1	1						1
42B	2	714350-22542	RING SET, 0.25 OS				1	1			1
46A	1	714280-22580	PISTON ASSY, 0.50 OS	1	1						2
46B	1	714380-22580	PISTON ASSY, 0.50 OS				1	1			2
48A	2	714250-22550	RING SET, 0.50 OS	1	1						2
48B	2	714350-22550	RING SET, 0.50 OS				1	1			2
52A	1	714250-23610	BEARING ASSY, 0.25	1	1						3
52B	1	714350-23610	BEARING ASSY, 0.25				1	1			3
54A	1	714250-23620	BEARING, 0.50 US	1	1						4
54B	1	714350-23620	BEARING, 0.50 US				1	1			4

Remarks

- (1) OVER-SIZE(O.S=0.25)PART.
- (2) OVER-SIZE(O.S=0.50)PART.
- (3) UNDER-SIZE(U.S=0.25)PART.
- (4) UNDER-SIZE(U.S=0.50)PART.

Fig.6. LUB. OIL PUMP & GOVERNOR

(A)=EP1700/2000
(B)=EP1700/2000S
(C)=EP2700/3100

(D)=EP2700/3100S
(E)=
(F)=

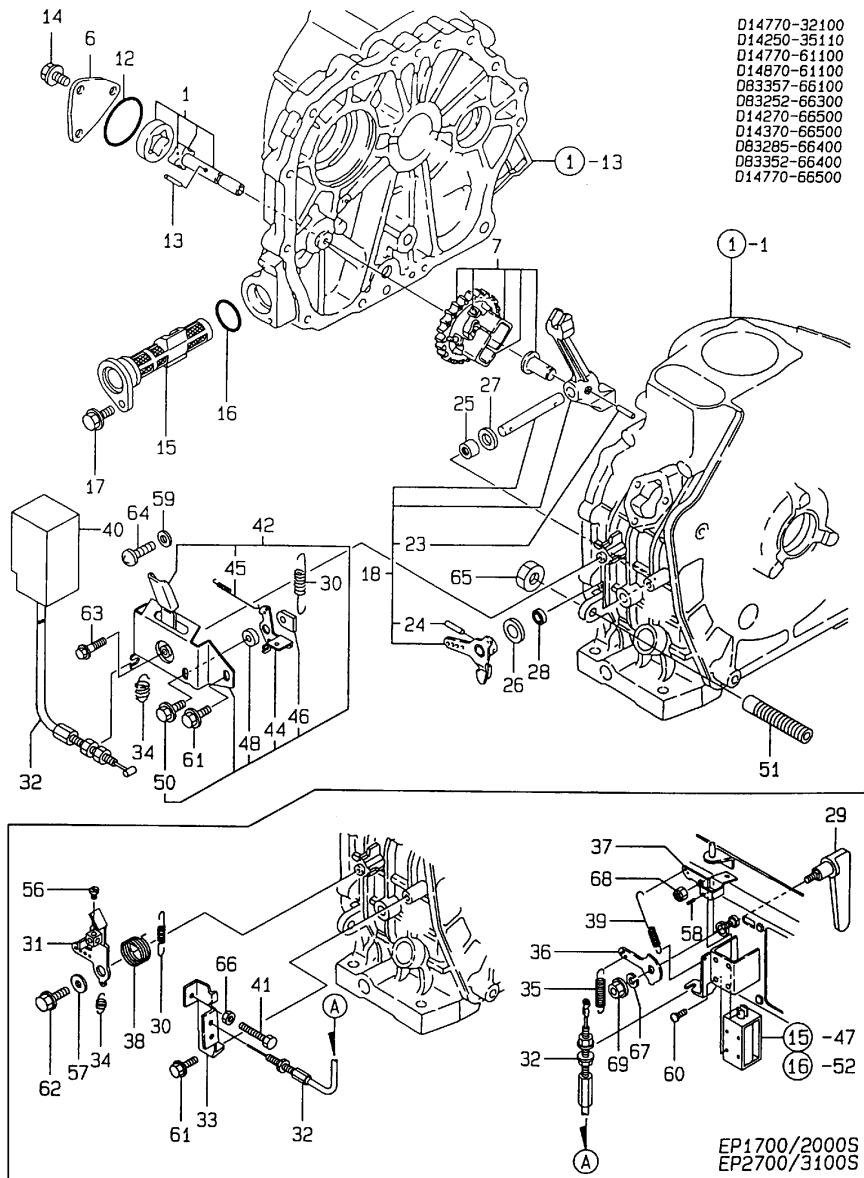

No.	Lev.	Parts No.	Description	Q'ty						I	R
				(A)	(B)	(C)	(D)	(E)	(F)		
1	1	114250-32010	PUMP ASSY, OIL	1	1	1	1				
6	1	114250-32070	COVER	1	1	1	1				
7	1	714770-61700	GOVERNOR ASSY	1	1	1	1				
12	1	103338-32570	O-RING	1	1	1	1				
13	1	22312-030160	PIN, PARALLEL M3X16	1	1	1	1				
14	1	26476-060142	SCREW, TAPPING M6X14	3	3	3	3				
15	1	114250-35070	FILTER, OIL	1	1	1	1				
16	1	24341-000224	O-RING, 1AS22.4	1	1	1	1				
17	1	26106-060162	BOLT, M6X 16 PLATED	1	1	1	1				
18A	1	714250-61501	LEVER ASSY, GOVERNOR	1	1						
18B	1	714350-61501	LEVER ASSY, GOVERNOR					1	1		
23	2	22322-030200	PIN, TAPER 3X20	1	1	1	1				
24	2	22322-030200	PIN, TAPER 3X20	1	1	1	1				
25	1	114270-61520	BEARING, NEEDLE 8	2	2	2	2				
26	1	114770-61610	WASHER, THRUST	1	1	1	1				
27	1	22137-080000	WASHER, 8	1	1	1	1				
28	1	114770-61600	SEAL, OIL	1	1	1	1				
29	1	183267-66350	LEVER, LOCK			1					
30A	1	114770-66010	SPRING, REGULATOR	1	1						
30B	1	114870-66010	SPRING, REGULATOR					1	1		
31	1	114883-66060	HANDLE, REGULATOR			1			1		
32A	1	183350-66420	WIRE, L=180	1							
32B	1	183266-66110	WIRE		1						
32C	1	183285-66420	WIRE			1					
33	1	114252-66120	BRACKET		1				1		
34	1	114250-66200	SPRING, RETURN	1	1	1	1				
35	1	183266-66210	SPRING		1				1		
36	1	183266-66230	LEVER, LOCK		1				1		
37	1	183267-66240	LEVER, LOCK		1				1		
38	1	114252-66252	SPRING, RETURN		1				1		
39	1	183250-66331	SPRING		1				1		
40	1	183250-66410	COVER	1					1		
41	1	114250-66440	BOLT, ADJUSTING		1				1		
42	1	183250-66511	BRACKET ASSY, HANDLE	1					1		
44	2	183250-66321	LEVER, LOCK	1					1		
45	2	183250-66331	SPRING	1					1		
46	2	183250-66341	NUT, LOCK	1					1		
48	2	183250-66361	COLLAR	1					1		
50	2	26106-060162	BOLT, M6X 16 PLATED	1					1		
51A	1	114770-66550	LIMITER ASSY, FUEL	1	1						1
51B	1	114250-66550	LIMITER ASSY, FUEL	1	1	1	1				2
56	1	105225-66990	SCREW, M5X8.5		1				1		
57	1	183350-55130	WASHER		1				1		
58	1	22351-030012	PIN, SPRING 3.0X12		1				1		
59	1	23418-050000	GASKET, 5X1.0	1					1		
60	1	26023-030082	SCREW, M3X 8		4				4		
61	1	26476-060142	SCREW, TAPPING M6X14	1	1	1	1				
62	1	26476-060202	SCREW, TAPPING M6X20		1				1		
63	1	26106-060202	BOLT, M6X 20 PLATED	1					1		
64	1	26557-040082	SCREW, M4X 8	2					2		
65	1	26696-100002	NUT, LOCK M10	1	1	1	1				

Remarks
(1) ONLY FOR EP1700,1700S.
(2) ONLY FOR EP2000,2000S.

Fig.7. COOLING & STARTING DEVICE

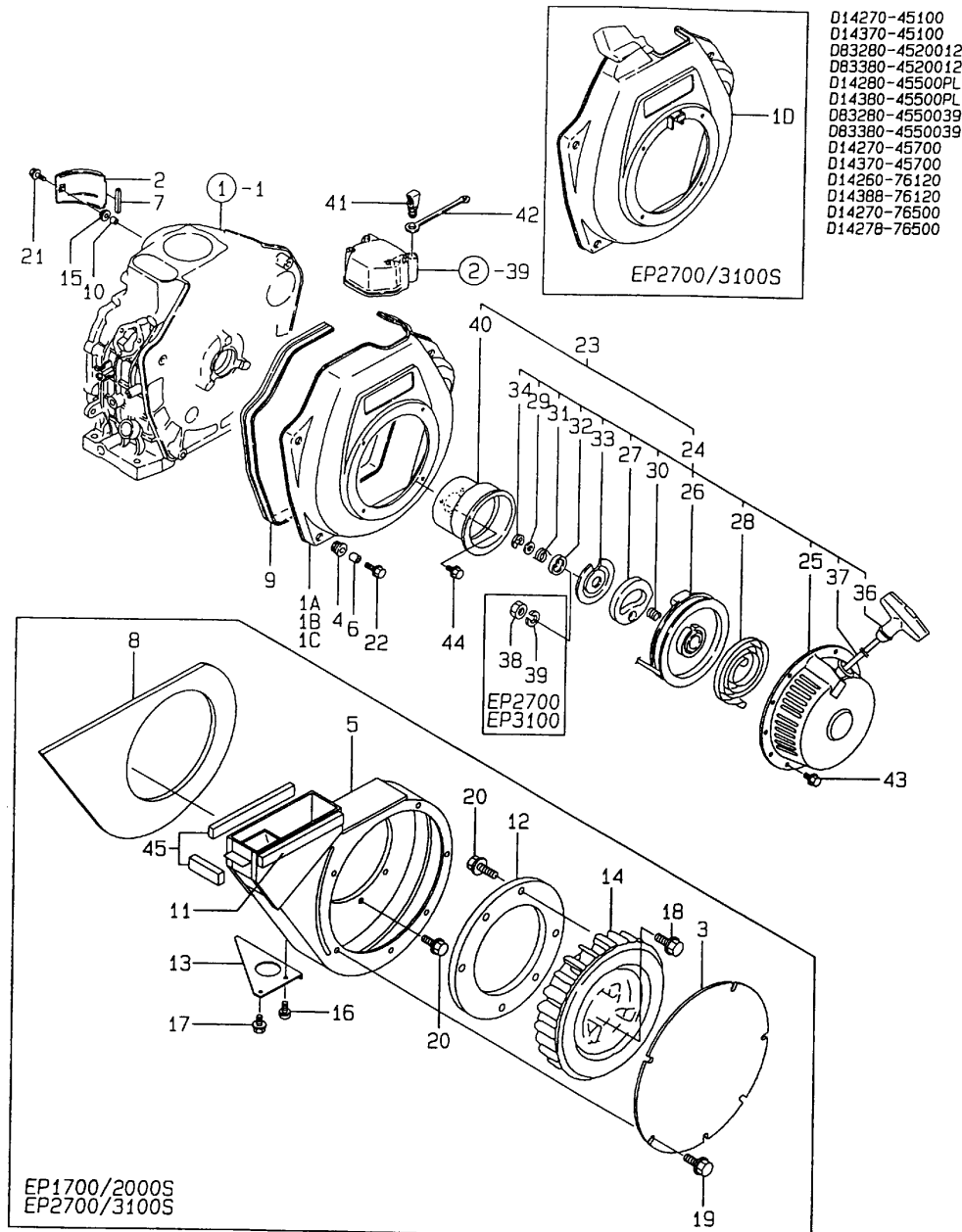

(A)=EP1700/2000
(B)=EP1700/2000S
(C)=EP2700/3100

(D)=EP2700/3100S
(E)=
(F)=

No.	Lev.	Parts No.	Description	Qty						I	R
				(A)	(B)	(C)	(D)	(E)	(F)		
1A	1	114780-45100-2	CASE, COOLING FAN	1							
1B	1	183266-45110	CASE, COOLING FAN		1						
1C	1	114360-45101-4	CASE, COOLING FAN			1					
1D	1	183366-45111	CASE, COOLING FAN				1				
2A	1	114250-45211	COVER	1	1						
2B	1	114870-45200	COVER			1	1				
3	1	183366-45220	COVER ASSY		1		1				
4	1	114250-45300	ABSORBER	4	4	5	5				
5	1	183366-45300	SCROLL		1		1				
6	1	114250-45310	COLLAR	4	4	5	5				
7	1	114350-45320	RUBBER, SEAL			1	1				
8	1	183366-45320	ISOLATOR		1		1				
9	1	114250-45330	SEAL, FAN CASE L=875	1	1	1	1				
10	1	114350-45340	COLLAR			1	1				
11	1	183266-45360	SPONGE		1						
12	1	183366-45410	COVER, FAN		1		1				
13A	1	183266-45460	STAY, SCROLL		1						
13B	1	183366-45460	STAY, SCROLL				1				
14	1	183366-45600	FAN, COOLING		1		1				
15	1	183720-55210	GROMMET			1	1				
16	1	26557-060142	SCREW M 6X 14		1		1				
17	1	26106-060142	BOLT, M6X 14 PLATED		1		1				
18	1	26014-080302	BOLT, M8X 30		3		3				
19	1	26106-060082	BOLT, M6X 8 PLATED		7		7				
20	1	26106-060122	BOLT, M6X 12 PLATED		14		14				
21A	1	26476-060142	SCREW, TAPPING M6X14	1	1						
21B	1	26476-060202	SCREW, TAPPING M6X20				1	1			
22	1	114370-45350	BOLT		4	4	5	5			
23A	1	114260-76050	STARTER ASSY, RECOIL	1							
23B	1	114880-76050	STARTER ASSY, RECOIL				1				
24A	2	114260-76250	STARTER ASSY, RECOIL	1							
24B	2	114880-76250	STARTER ASSY, RECOIL				1				
25A	3	114260-76520	CASE, STARTER	1							
25B	3	114880-76510	CASE, STARTER				1				
26A	3	160260-76520	REEL	1							
26B	3	160810-76520	REEL				1				
27A	3	160260-76530	RATCHET	1							
27B	3	160840-76530	RATCHET				1				
28A	3	160260-76540	SPRING, SPIRAL	1							
28B	3	160810-76540	SPRING, SPIRAL				1				
29	3	160260-76550	WASHER, THRUST	1							
30A	3	160260-76560	SPRING, FRICTION	1							
30B	3	160840-76560	SPRING, FRICTION				1				
31	3	160290-76570	SPRING, RETURN	1							
32	3	160260-76580	COVER	1							
33A	3	160260-76590	PLATE, FRICTION	1							
33B	3	160810-76580	PLATE, FRICTION				1				
34	3	160260-76600	CIRCLIP	1							
36A	3	160260-76620	KNOB, STARTER	1							
36B	3	160810-76620	KNOB, STARTER				1				
37A	3	160260-76630	ROPE, STARTER	1							

Fig.7. COOLING & STARTING DEVICE

(A)=EP1700/2000
 (B)=EP1700/2000S
 (C)=EP2700/3100

(D)=EP2700/3100S
 (E)=
 (F)=

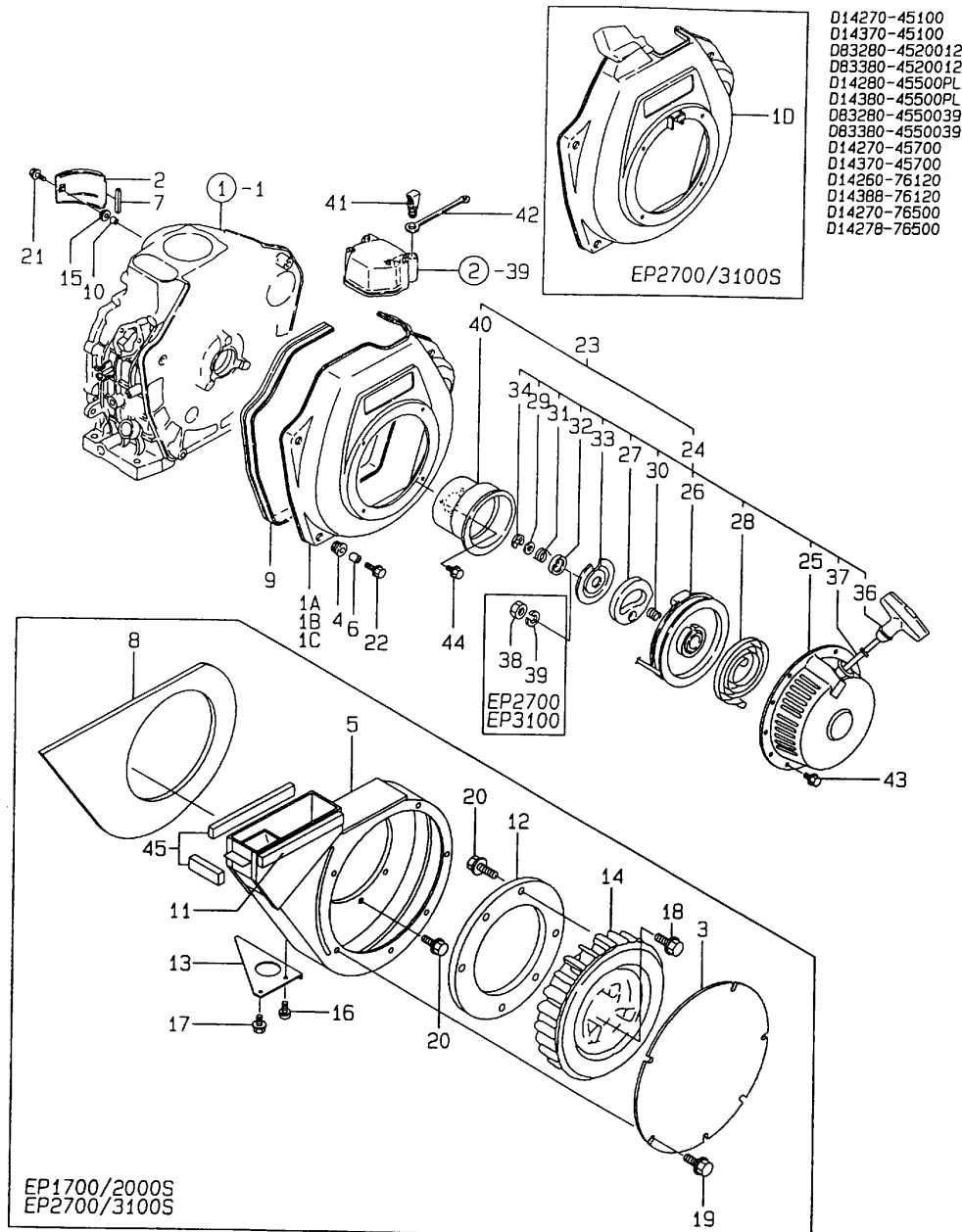

No.	Lev.	Parts No.	Description	Qty						I	R
				(A)	(B)	(C)	(D)	(E)	(F)		
37B	3	160810-76630	ROPE, STARTER			1					
38	3	181130-76680	NUT			1					
39	3	181130-76700	WASHER			1					
40A	2	114250-76590	PULLEY, STARTER	1							
40B	2	114350-76590	PULLEY, STARTER			1					
41	1	114250-76600	PLUNGER	1		1					
42	1	114250-76610	HOLDER, PLUNGER	1		1					
43	1	26106-060082	BOLT, M6X 8 PLATED	4		4					
44	1	26106-060122	BOLT, M6X 12 PLATED	3		3					
45	1	183294-95300	SPONGE ASSY		1		1				

Fig.8. FUEL INJECTION PUMP

(A)=EP1700/2000
 (B)=EP1700/2000S
 (C)=EP2700/3100

(D)=EP2700/3100S
 (E)=
 (F)=

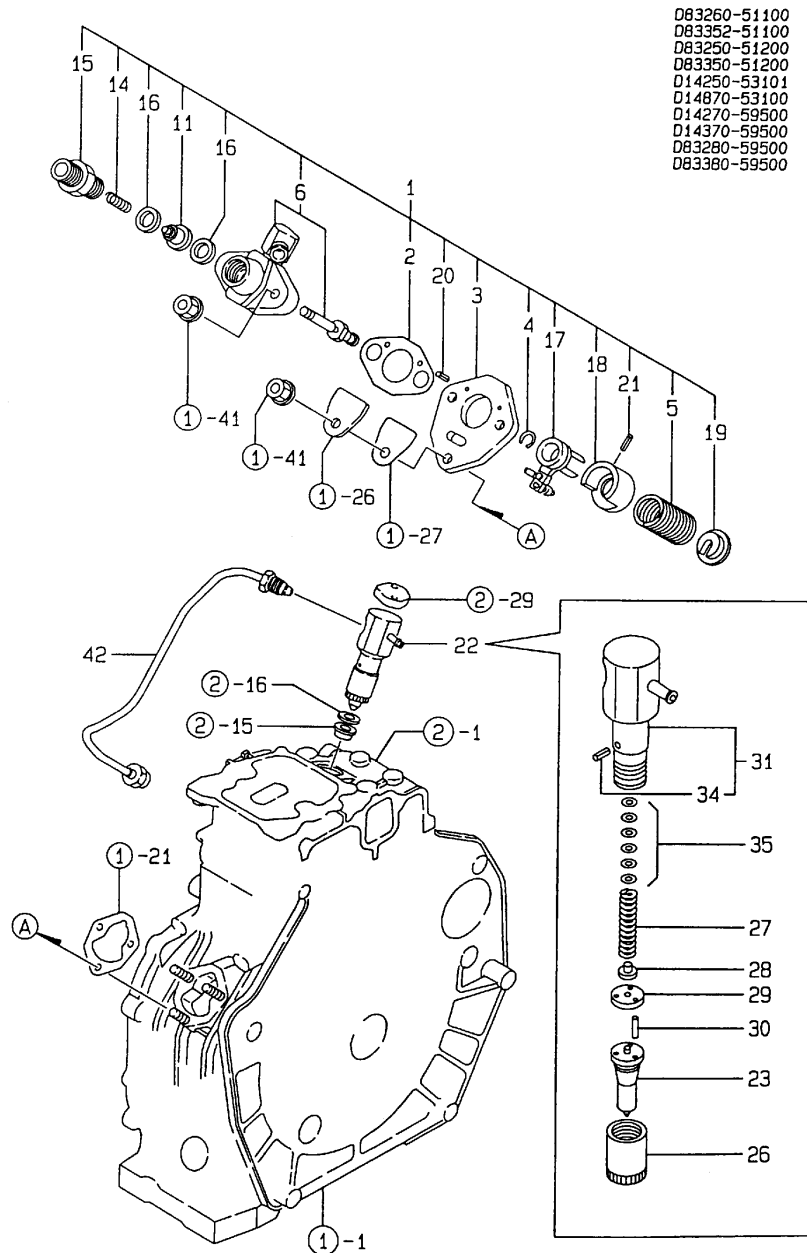

No.	Lev.	Parts No.	Description	Qty						I	R
				(A)	(B)	(C)	(D)	(E)	(F)		
1A	1	783250-51701	PUMP ASSY, INJECTION	1	1						
1B	1	783350-51701	PUMP ASSY, INJECTION					1	1		
2	2	105546-51020	GASKET	1	1	1	1				
3	2	114250-51080	PLATE	1	1	1	1				
4	2	114250-51150	RING, SNAP	1	1	1	1				
5	2	114250-51160	SPRING, PLUNGER	1	1	1	1				
6A	2	183250-51200	BODY ASSY, PUMP	1	1						
6B	2	183350-51200	BODY ASSY, PUMP					1	1		
11	2	114250-51300	VALVE ASSY, DELIVERY	1	1	1	1				
14	2	105546-51330	SPRING, DELIVERY	1	1	1	1				
15	2	114250-51340	HOLDER, DELIVERY	1	1	1	1				
16	2	124550-51350	GASKET, DELIVERY	2	2	2	2				
17	2	114250-51600	LEVER ASSY, CONTROL	1	1	1	1				
18	2	114250-51640	SEAT, SPRING A	1	1	1	1				
19	2	114250-51650	SEAT, SPRING B	1	1	1	1				
20	2	22351-020006	PIN, SPRING 2.0X 6	2	2	2	2				
21	2	22351-030008	PIN, SPRING 3.0X 8	1	1	1	1				
22A	1	714250-53101	VALVE ASSY,INJECTION	1	1						
22B	1	714870-53100	VALVE ASSY,INJECTION					1	1		
23A	2	114250-53001	VALVE ASSY,INJECTION	1	1						
23B	2	114870-53000	VALVE ASSY,INJECTION					1	1		
26	2	114250-53080	NUT, NOZZLE D16.95	1	1	1	1				
27	2	114250-53120	SPRING, NOZZLE	1	1	1	1				
28	2	114250-53130	SEAT, SPRING	1	1	1	1				
29	2	114250-53140	PLATE	1	1	1	1				
30	2	114250-53210	PIN	2	2	2	2				
31	2	114250-53300	HOLDER ASSY, NOZZLE	1	1	1	1				
34	3	114250-53331	PIN	1	1	1	1				
35	2	114250-53400	SHIM SET	1	1	1	1				
42A	1	183250-59800	PIPE ASSY, INJECTION	1							
42B	1	114250-59800	PIPE ASSY, INJECTION		1						
42C	1	183350-59800	PIPE ASSY, INJECTION					1			
42D	1	114350-59800	PIPE ASSY, INJECTION						1		

Fig.9. FUEL TANK & FUEL LINE

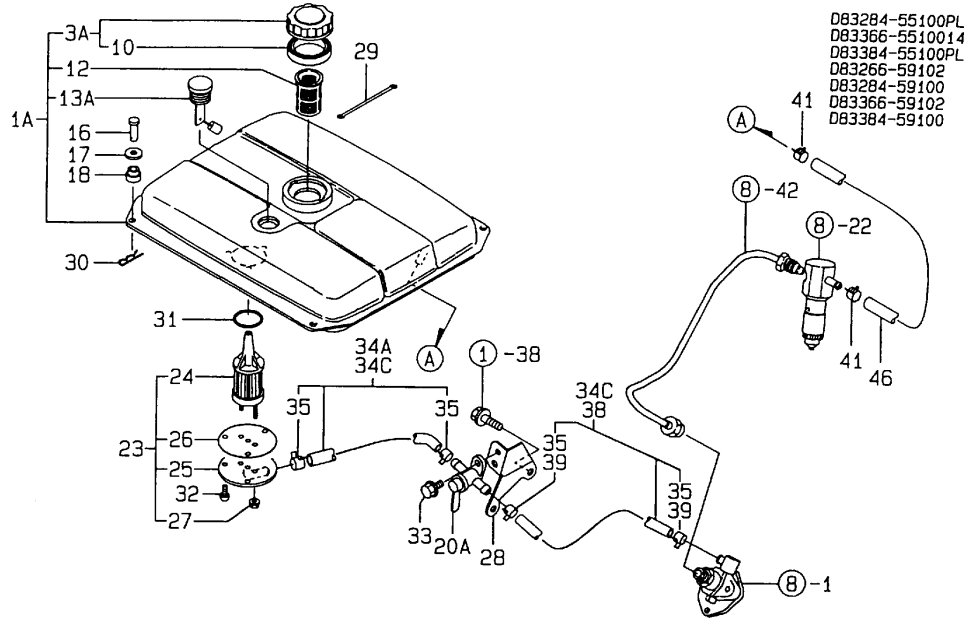

DB3284-55100PL
DB3366-5510014
DB3384-55100PL
DB3266-59102
DB3284-59100
DB3366-59102
DB3384-59100

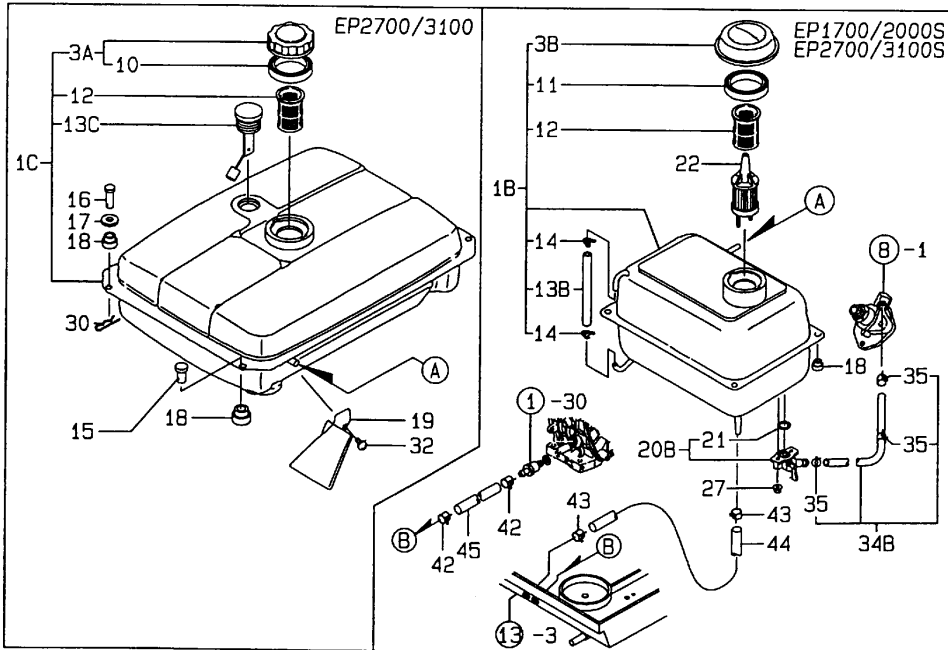

(A)=EP1700/2000
(B)=EP1700/2000S
(C)=EP2700/3100

(D)=EP2700/3100S
(E)=
(F)=

No.	Lev.	Parts No.	Description	Qty						I	R
				(A)	(B)	(C)	(D)	(E)	(F)		
1A	1	783284-55700-1	TANK ASSY, FUEL	1							
1B	1	783366-55700-1	TANK,FUEL(WHITE)(14)		1		1				
1C	1	783384-55700-1	TANK ASSY, FUEL			1					
3A	2	160710-55061	CAP ASSY	1		1					
3B	2	105015-55040	CAP, FUEL TANK		1		1				
10	3	160393-55050	GASKET	1		1					
11	2	101504-55051	GASKET		1		1				
12	2	160710-55100	FILTER, FUEL	1	1	1	1				
13A	2	183925-55150	GAUGE	1							
13B	2	183366-55150	GAUGE, LEVEL		1		1				
13C	2	183621-55150	GAUGE			1					
14	2	103854-55220	RETAINER		2		2				
15	1	183350-55110	PIN, 6X12				2				
16	1	183350-55120	PIN, 6X14	4		2					
17	1	183350-55130	WASHER	4		2					
18	1	183720-55210	GROMMET	4	4	4	4				
19	1	183350-55260	PLATE, GUIDE				1				
20A	1	183284-55300	COCK ASSY, FUEL	1		1					
20B	1	183250-55320	COCK ASSY, FUEL		1		1				
21	2	24341-000150	O-RING, 1AS15.0		1		1				
22	1	183366-55120	FILTER, FUEL		1		1				
23A	1	183284-55311	FILTER ASSY, FUEL	1							
23B	1	183384-55311	FILTER ASSY, FUEL				1				
24A	2	183284-55321	FILTER, FUEL	1							
24B	2	183384-55321	FILTER, FUEL				1				
25	2	183284-55331	PLATE	1		1					
26	2	183284-55341	GASKET	1		1					
27	2	26366-060002	NUT, M6	2	2	2	2				
28A	1	183284-55400	STAY	1							
28B	1	183384-55401	STAY				1				
29	1	114250-76610	HOLDER, PLUNGER	1							
30	1	22360-060000	PIN, SNAP 6	4		2					
31	1	24311-000400	O-RING, 1AP40.0	1		1					
32	1	26022-050102	SCREW, M5X10	3		5					
33	1	26106-060122	BOLT, M6X 12 PLATED	1		1					
34A	1	183284-59010	PIPE ASSY, FUEL	1							
34B	1	183366-59010	PIPE ASSY, FUEL		1		1				
34C	1	183384-59010	PIPE ASSY, FUEL				2				
35	2	106990-44660	CLIP, HOSE 12.5	2	3	4	3				
38	1	183284-59020	PIPE ASSY, FUEL	1							
39	2	106990-44660	CLIP, HOSE 12.5	2							
41	1	124722-59050	CLIP, HOSE 9	2	2	2	2				
42	1	171008-03990	CLIP, HOSE 18.5		2		2				
43	1	106990-44660	CLIP, HOSE 12.5		2		2				
44	1	183366-59330	PIPE, FUEL RETURN		1		1				
45A	1	183366-59341	PIPE		1						
45B	1	183366-59351	PIPE, FUEL RETURN				1				
46A	1	183284-59060	PIPE, FUEL RETURN	1							
46B	1	183671-59060	PIPE, FUEL RETURN		1		1				
46C	1	183350-59060	PIPE, FUEL RETURN				1				

Fig.10. STARTING MOTOR & DYNAMO

(A)=EP1700/2000
 (B)=EP1700/2000S
 (C)=EP2700/3100

(D)=EP2700/3100S
 (E)=
 (F)=

発行No. 000Y00D4890-1
 更新年月: 2005.05
 REVISED: May, 2005

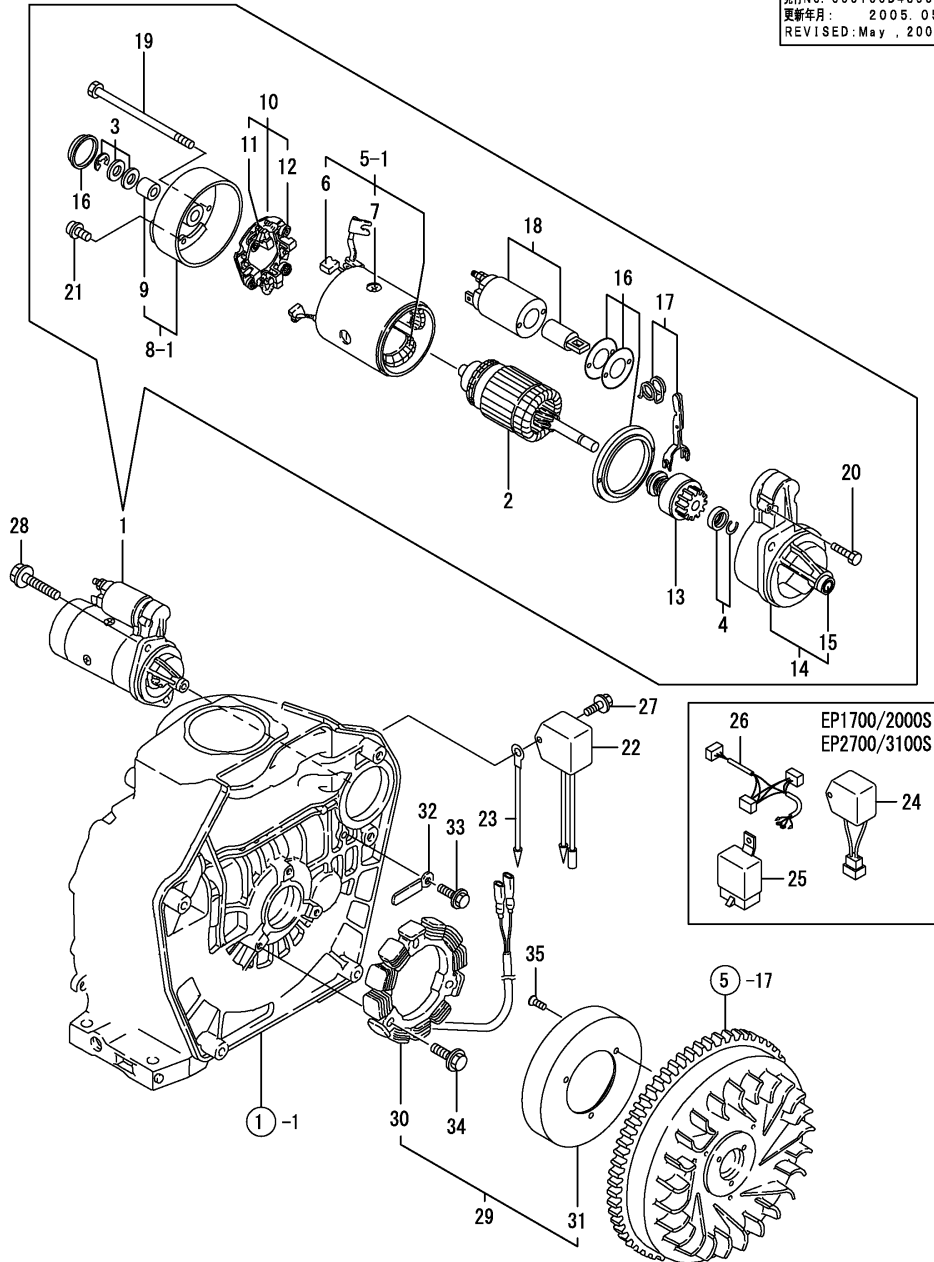

No.	Lev.	Parts No.	Description	Qty						I	R
				(A)	(B)	(C)	(D)	(E)	(F)		
1	1	114362-77010	STARTER, S114-414A	1	1	1					
2	2	X211461104	ARMATURE	1	1	1					
3	2	X21148110	WASHER SET, THRUST	1	1	1					
4	2	X21147155	STOPPER SET, PINION	1	1	1					
5-1	2	X211492108	COIL ASSY, FIELD	1	1	1					
6	3	X21145312	BRUSH, +	2	2	2					
7	3	X21143215	SCREW, CORE	4	4	4					
8-1	2	X211473008	COVER, REAR	1	1	1					
9	3	X21145352	METAL	1	1	1					
10	2	X211489001	HOLDER ASSY, BRUSH	1	1	1					
11	3	X21148313	BRUSH (-)	1	1	1					
12	3	X21149314	SPRING, BRUSH	3	3	3					
13	2	X211445508	PINION ASSY	1	1	1					
14	2	X211416603	HOUSING ASSY, GEAR	1	1	1					
15	3	X21145352	METAL	1	1	1					
16	2	X211478006	COVER KIT	1	1	1					
17	2	X211456013	LEVER KIT, SHIFT	1	1	1					
18	2	X211427501	SWITCH, MAGNETIC	1	1	1					
19	2	X211468005	BOLT, THROUGH	2	2	2					
20	2	X21145867	BOLT, M6	2	2	2					
21	2	X21142835	SCREW SET	1	1	1					
22	1	160970-77350	RECTIFIER, ZR2117			1					
23	1	183350-77400	WIRE, LEAD	1	1	1					
24	1	183256-78300	REGULATOR	1		1					
25	1	183256-78310	RELAY	1		1					
26	1	183267-91390	HARNES, WIRE	1		1					
27	1	26106-060122	BOLT, M6X 12 PLATED			1					
28	1	26106-100302	BOLT, M10X 30 PLATED	2	2	2					
29	1	114351-78250	DYNAMO ASSY	1	1	1					
30	2	114351-78750	STATOR ASSY	1	1	1					
31	2	114351-78760	WHEEL, DYNAMO	1	1	1					
32	1	160710-78710	CLAMP, CORD	1	1	1					
33	1	26476-060142	SCREW, TAPPING M6X14	1	1	1					
34	1	26476-060202	SCREW, TAPPING M6X20	3	3	3					
35	1	26577-060142	SCREW M 6X 14	3	3	3					

Fig.11. TOOL,LABEL & GASKET SET

(A)=EP1700/2000
(B)=EP1700/2000S
(C)=EP2700/3100

(D)=EP2700/3100S
(E)=
(F)=

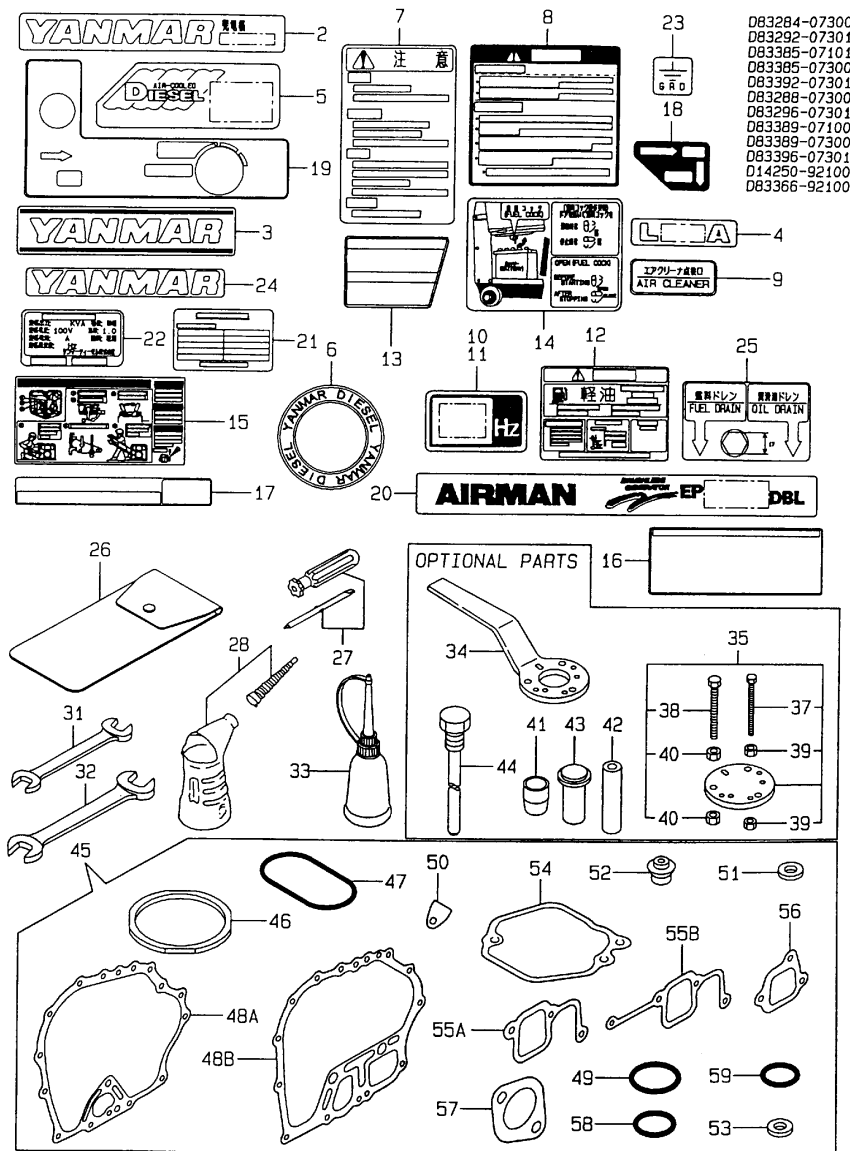

No.	Lev.	Parts No.	Description	Q'ty						I	R
				(A)	(B)	(C)	(D)	(E)	(F)		
2	1	183385-07200	LABEL			1					
3	1	183250-07110	LABEL, YANMAR			1					
4	1	114370-07050	LABEL(L60A)			1					
5	1	183384-07250	LABEL, KVA			1					
6	1	114250-07350	LABEL, YANMAR DIESEL			1					
7	1	170001-07230	LABEL,MUFFLER CAUTIO	1		1					
8	1	183366-07290	LABEL		1		1				
9	1	183366-07280	LABEL, AIR CLEANER		1		1				
10	1	183610-07230	LABEL, 50HZ	1	1	1	1				1
11	1	183620-07230	LABEL, 60HZ	1	1	1	1				2
12	1	183250-07260	LABEL, CAUTION	1	1	1	1				
13	1	183284-07351	LABEL, F.O.COCK	1		1					
14	1	183366-07251	LABEL, F.O. COCK		1		1				
15	1	183284-07370	LABEL, OPERATION	1		1					
16	1	183292-07210	LABEL, OPERATION		1		1				
17	1	183250-07450	LABEL	1	1	1	1				
18	1	183250-07480	LABEL, RUN-STOP	1		1					
19	1	183267-07230	LABEL		1		1				
20A	1	183284-07750	LABEL	1							1
20B	1	183288-07750	LABEL	1							2
20C	1	183294-07750	LABEL		2						1
20D	1	183298-07750	LABEL		2						2
20E	1	183385-07750	LABEL			1					1
20F	1	183389-07750	LABEL			1					2
20G	1	183394-07750	LABEL				2				1
20H	1	183398-07750	LABEL				2				2
21A	1	183252-07870	LABEL, GENERATOR	1							1
21B	1	183262-07870	LABEL, GENERATOR	1							2
21C	1	183252-07870	LABEL, GENERATOR		1						1
21D	1	183262-07870	LABEL, GENERATOR		1						2
21E	1	183352-07870	LABEL, GENERATOR			1					1
21F	1	183362-07870	LABEL, GENERATOR			1					2
21G	1	183352-07870	LABEL, GENERATOR				1				1
21H	1	183362-07870	LABEL, GENERATOR				1				2
22A	1	183385-07551	LABEL, GENERATOR			1					1
22B	1	183389-07550	LABEL, GENERATOR			1					2
23	1	183210-07390	LABEL, G.R.D.		1		1				
24	1	183284-07900	LABEL, YANMAR			1					
25	1	183366-07240	LABEL, DAIN		1		1				
26	1	114250-92600	BAG, TOOL	1	1	1	1				
27	1	160330-92730	DRIVE, SCREW	1	1	1	1				
28	1	7E4133-99290	JUG ASSY, OIL			1		1			
31	1	28110-100120	SPANNER, 10X12	1	1	1	1				
32	1	28110-140170	SPANNER, 14X17	1	1	1	1				
33	1	28210-000150	OILER	1	1	1	1				
34	1	114250-92101	F.W. LOCKING HANDLE	1	1	1	1				3
35	1	114250-92130	REMOVER, FLYWHEEL	1	1	1	1				3
37	2	26116-060454	BOLT M 6X 45 PLATED	4	4	4	4				3
38	2	26116-080454	BOLT, M8X 45 PLATED	3	3	3	3				3
39	2	26716-060002	NUT, M6	8	8	8	8				3
40	2	26716-080002	NUT, M8	6	6	6	6				3

Remarks

- (1) ONLY FOR EP1700/1700S/2700/2700S.
- (2) ONLY FOR EP2000/2000S/3100/3100S.
- (3) OPTIONAL PART.

Fig.11. TOOL,LABEL & GASKET SET

(A)=EP1700/2000
(B)=EP1700/2000S
(C)=EP2700/3100

(D)=EP2700/3100S
(E)=
(F)=

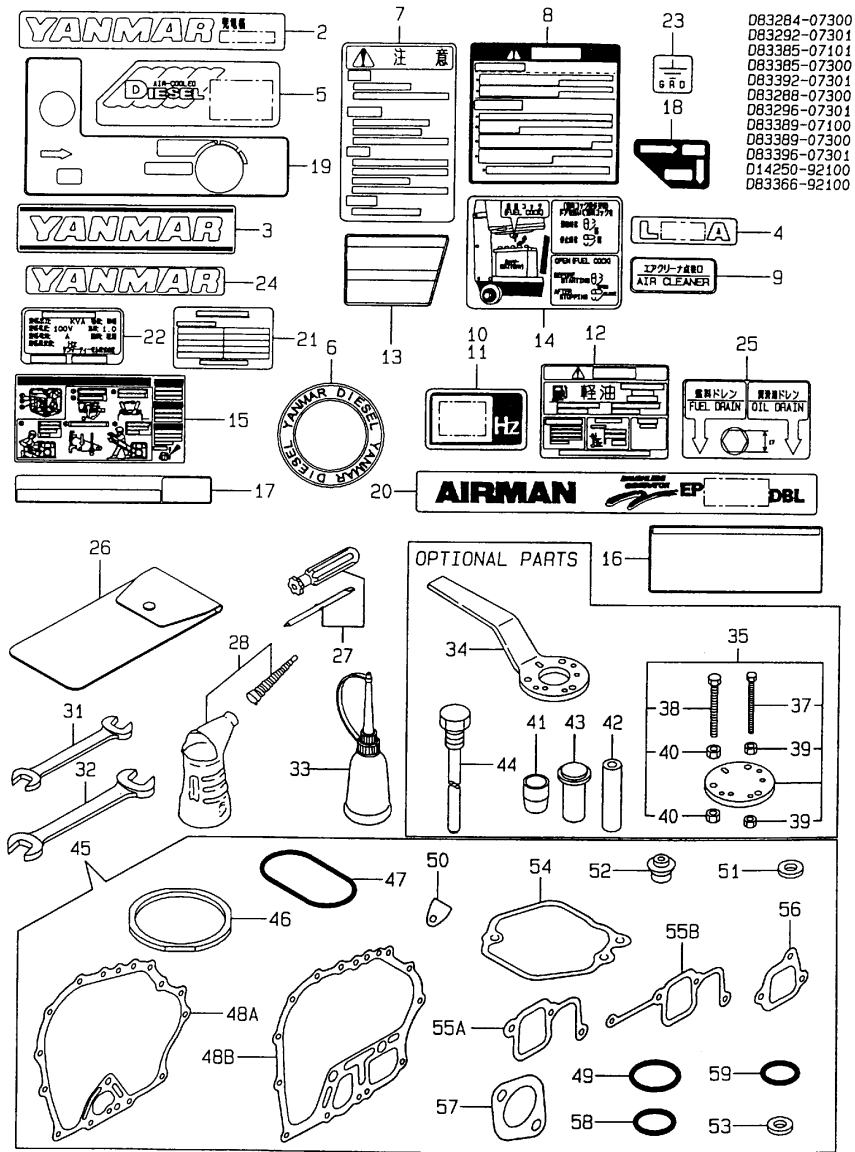

No.	Lev.	Parts No.	Description	Q'ty						I	R
				(A)	(B)	(C)	(D)	(E)	(F)		
41A	1	114350-92301	GUIDE, OIL SEAL	1	1						3
41B	1	114361-92300	GUIDE, OIL SEAL				1	1			3
42A	1	114250-92311	INSTALLING TOOL	1	1						3
42B	1	114350-92311	INSTALLING TOOL				1	1			3
43A	1	114250-92350	INSTALLING TOOL	1	1						3
43B	1	114350-92350	INSTALLING TOOL				1	1			3
44A	1	183262-92350	TOOL, ROTOR REMOVER	1	1						3
44B	1	183362-92350	TOOL, ROTOR REMOVER				1	1			3
45A	1	714250-92602	GASKET SET	1	1						3
45B	1	714350-92602	GASKET SET				1	1			3
46A	2	114250-01340	GASKET, HEAD	1	1						
46B	2	114350-01340	GASKET, HEAD					1	1		
47A	2	114250-01380	O-RING	1	1						
47B	2	114350-01380	O-RING					1	1		
48A	2	114250-01412	GASKET, CRANK CASE	1	1						
48B	2	114350-01412	GASKET, CRANK CASE					1	1		
49	2	24311-000180	O-RING, 1AP18.0	2	2	2	2				
50	2	114250-01840	GASKET	1	1	1	1				
51	2	43400-500490	SEAL WASHER 16S	2	2	2	2				
52A	2	114250-11340	SEAL, VALVE STEM	2	2						
52B	2	114350-11340	SEAL, VALVE STEM				2	2			
53	2	114250-11460	GASKET, NOZZLE	1	1	1	1				
54	2	114250-11310	GASKET, BONNET	1	1	1	1				
55A	2	114250-12200	GASKET	1	1						
55B	2	114350-12201	GASKET					1	1		
56	2	114250-12210	GASKET, AIR CLEANER	1	1	1	1				
57	2	114250-13200	GASKET, MUFFLER	1	1	1	1				
58	2	103338-32570	O-RING	1	1	1	1				
59	2	24341-000224	O-RING, 1AS22.4	1	1	1	1				

Remarks

- (1) ONLY FOR EP1700/1700S/2700/2700S.
- (2) ONLY FOR EP2000/2000S/3100/3100S.
- (3) OPTIONAL PART.

Fig.12. FRAME & BATTERY

(A)=EP1700/2000
 (B)=EP1700/2000S
 (C)=EP2700/3100

(D)=EP2700/3100S
 (E)=
 (F)=

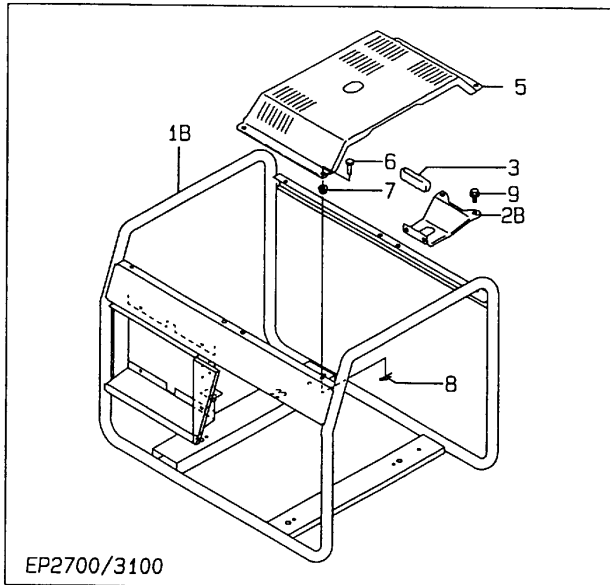
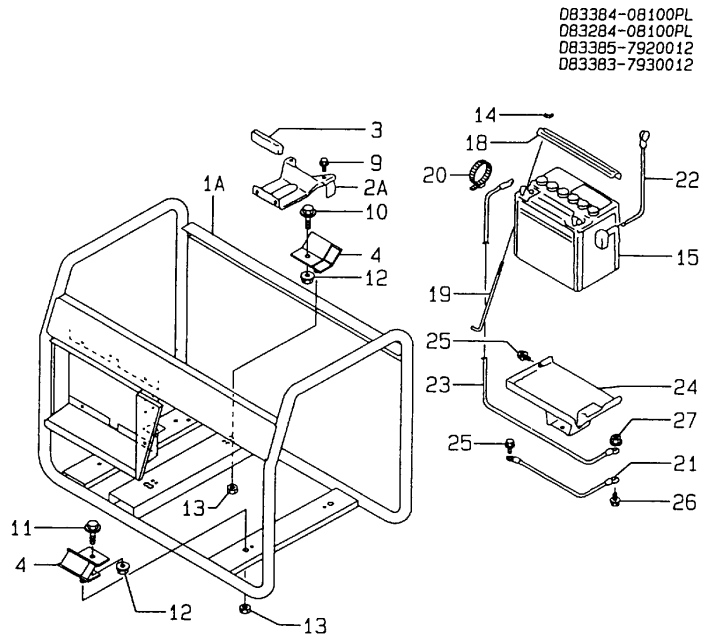

No.	Lev.	Parts No.	Description	Qty						I	R
				(A)	(B)	(C)	(D)	(E)	(F)		
1A	1	183284-08010-2	FRAME ASSY	1							
1B	1	183384-08010-1	FRAME ASSY			1					
2A	1	183250-08150	STOPPER	1							
2B	1	183350-08150	STOPPER				1				
3	1	183250-08160	RUBBER, STOPPER	1		1					
4	1	183284-08250	DAMPER	4		4					
5	1	183384-08350-1	COVER, ENGINE				1				
6	1	183350-55120	PIN, 6X14				4				
7	1	183720-55210	GROMMET				4				
8	1	22360-060000	PIN, SNAP 6				4				
9	1	26106-080162	BOLT, M8X 16 PLATED	2		2					
10	1	26106-100352	BOLT, M10X 35 PLATED	2		2					
11	1	26106-100402	BOLT, M10X 40 PLATED	2		2					
12	1	26366-100002	NUT, M10	4		4					
13	1	26696-100002	NUT, LOCK M10	4		4					
14	1	101147-12550	NUT				2				
15	1	183350-79510	BATTERY ASSY, 26A19L				1				
18	1	183350-79630	RETAINER, BATTERY				1				
19	1	183920-79650	BOLT, BATTERY				2				
20	1	121750-59890	BAND, 140				1				
21	1	183350-79550	CABLE, -				1				
22	1	183350-79560	CABLE, +				1				
23	1	183920-79560	CABLE, -				1				
24	1	183350-79610	BRACKET, BATTERY				1				
25	1	26106-060102	BOLT, M6X 10 PLATED				4				
26	1	26106-080302	BOLT, M8X 30 PLATED				1				
27	1	26366-080002	NUT, M8				1				

Fig.13. SOUND-PROOF CASE

(A)=EP1700/2000 (D)=EP2700/3100S
 (B)=EP1700/2000S (E)=
 (C)=EP2700/3100 (F)=

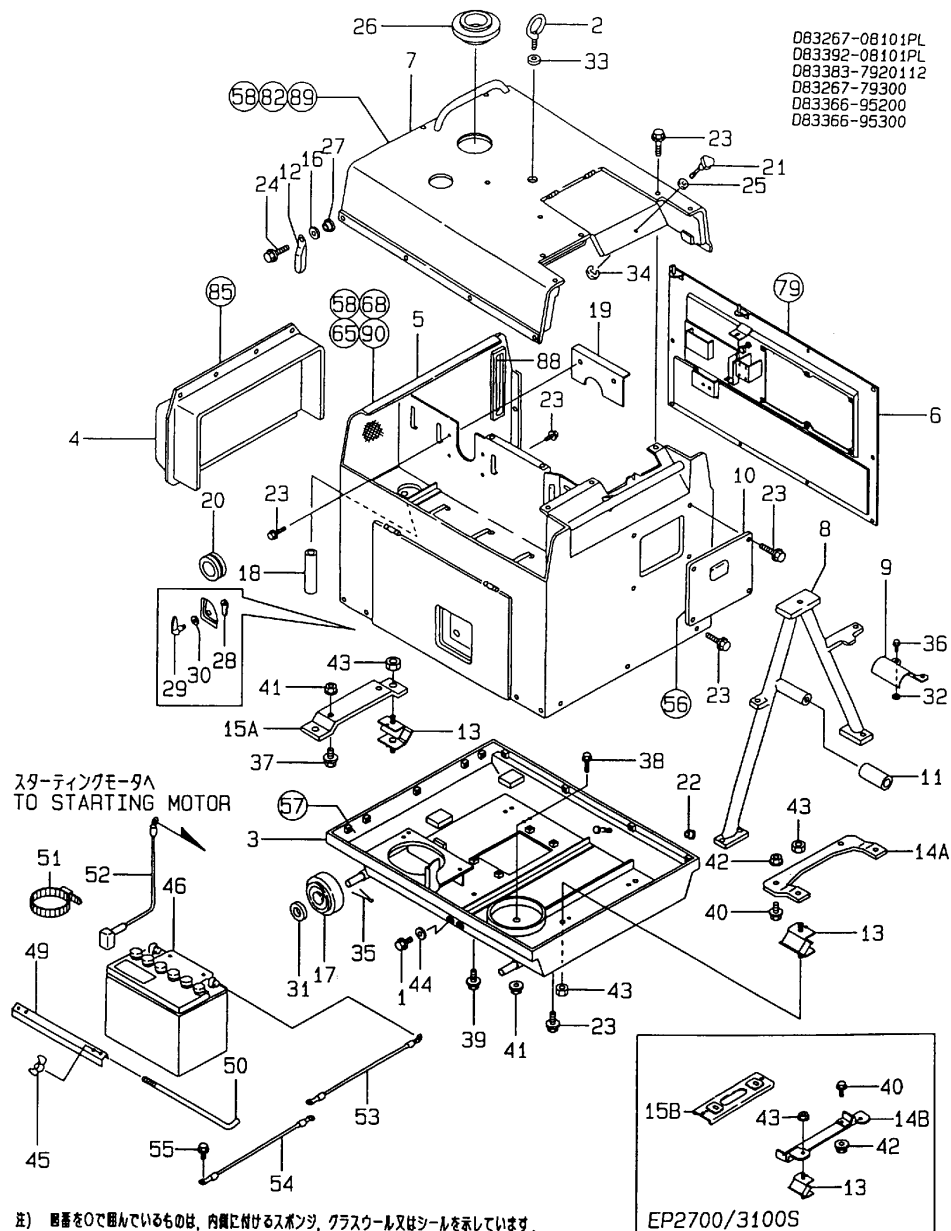

注) 番号をOで囲んでいるものは、内側に付けるスポンジ、グラスウール又はシールを示しています。
 Note) The encircled drawing numbers indicate the parts lined with rubber sponge, glass wool or some kinds of seal.

No.	Lev.	Parts No.	Description	Qty						I	R
				(A)	(B)	(C)	(D)	(E)	(F)		
1	1	105425-01690	PLUG, 16		2		2				
2	1	105990-07920	BOLT, EYE M14		1		1				
3	1	183366-08051-1	CASE		1		1				
4	1	183366-08080-4	COVER		1		1				
5	1	183366-08091-4	CASE		1		1				
6	1	183267-08100-1	CASE		1		1				
7	1	183366-08111-4	CASE		1		1				
8	1	183294-08120	FRAME, LIFTING		1		1				
9A	1	183266-08150	STOPPER		1						
9B	1	183366-08150	STOPPER						1		
10	1	183366-08170-4	COVER		1		1				
11	1	183366-08180	RUBBER		1		1				
12	1	183366-08190-1	STOPPER		1		1				
13	1	183250-08220	DAMPER		4		4				
14A	1	183266-08240	STAY, DAMPER		1						
14B	1	183392-08230	STAY, DAMPER						1		
15A	1	183267-08240	STAY, DAMPER		1						
15B	1	183392-08250	STAY, DAMPER						1		
16	1	183366-08290	WASHER		1		1				
17	1	183266-08360	WHEEL, 100		4		4				
18	1	183366-08400	PIPE, WATER DRAIN		1		1				
19A	1	183366-08461	FLANGE		1						
19B	1	183366-08460	FLANGE						1		
20	1	183366-08470	COVER, MUFFLER		1		1				
21	1	183101-08550	BOLT		1		1				
22	1	183210-08810	NUT		1		1				
23	1	183366-08900	BOLT, M6X14		52		52				
24	1	183267-08910	BOLT, M6X25		1		1				
25	1	183350-55130	WASHER		1		1				
26	1	183366-55210	GROMMET		1		1				
27	1	160810-55480	PIECE		1		1				
28	1	194312-61810	CAM, BONNET LOCK		1		1				
29	1	194555-61820	LEVER, BONNET LOCK		1		1				
30	1	194312-61840	WASHER, BWW-626		1		1				
31	1	22117-120000	WASHER, 12		4		4				
32	1	22137-080000	WASHER, 8		2		2				
33	1	22137-140000	WASHER, 14		1		1				
34	1	22272-000050	RING, E- 5		4		1				
35	1	22417-320250	PIN, COTTER 3.2X25		4		4				
36	1	26106-080202	BOLT, M8X 20 PLATED		2		2				
37	1	26106-080252	BOLT, M8X 25 PLATED		2						
38A	1	26106-080602	BOLT, M8X 60 PLATED		1						
38B	1	26106-080452	BOLT, M8X 45 PLATED						1		
39	1	26106-100162	BOLT, M10X 16 PLATED		2		2				
40	1	26106-100382	BOLT, M10X 38 PLATED		2		3				
41	1	26366-080002	NUT, M8		4		4				
42	1	26366-100002	NUT, M10		2		2				
43	1	26696-100002	NUT, LOCK M10		8		8				
44	1	43400-500490	SEAL WASHER 16S		2		2				
45	1	101147-12550	NUT		2		2				
46	1	183350-79510	BATTERY ASSY, 26A19L		1		1				

Fig.13. SOUND-PROOF CASE

(A)=EP1700/2000
 (B)=EP1700/2000S
 (C)=EP2700/3100

(D)=EP2700/3100S
 (E)=
 (F)=

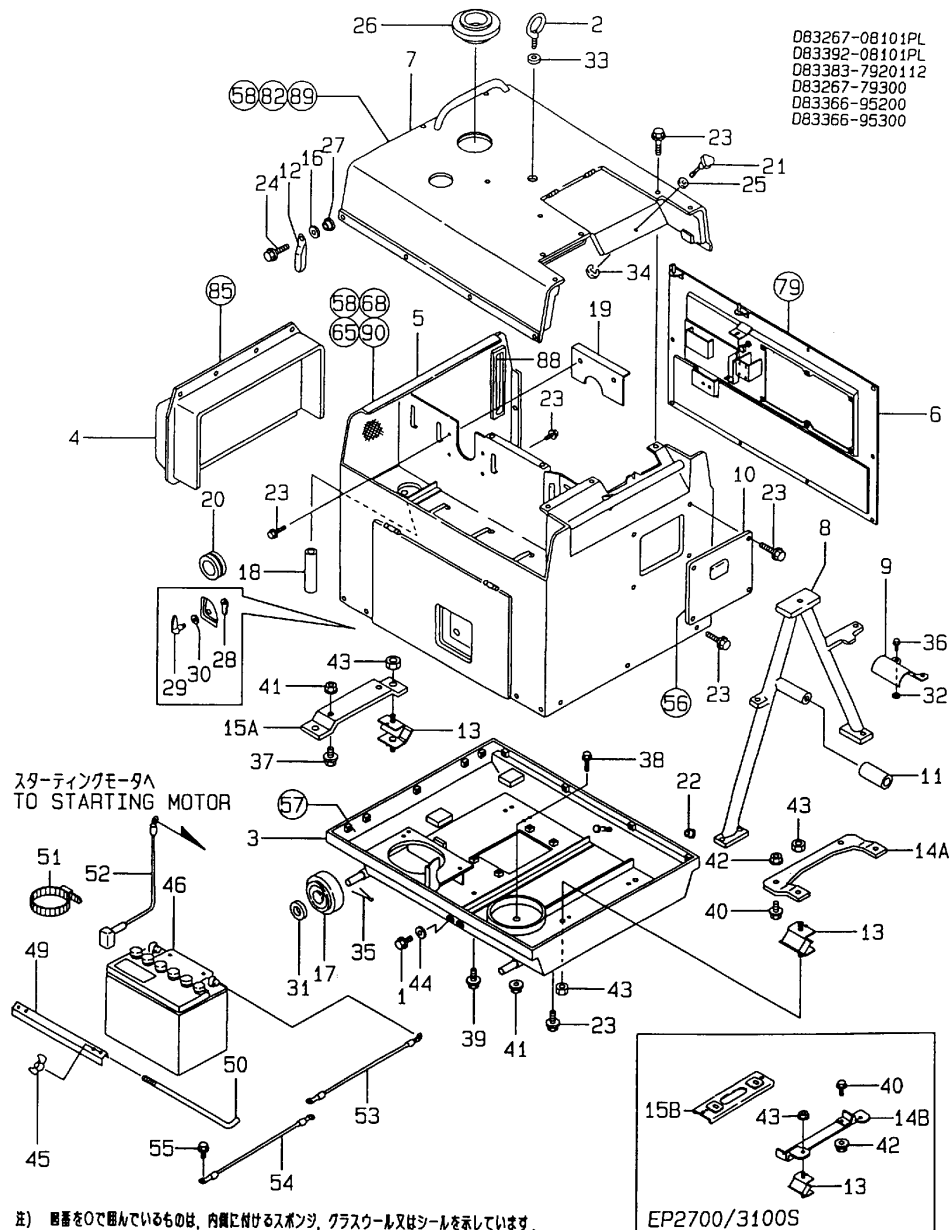

注) 図番をOで囲んでいるものは、内側に付けるスポンジ、グラスウール又はシルを示しています。
 Note) The encircled drawing numbers indicate the parts lined with rubber sponge, glass wool or some kinds of seal.

No.	Lev.	Parts No.	Description	Qty						I	R
				(A)	(B)	(C)	(D)	(E)	(F)		
49	1	183350-79630	RETAINER, BATTERY		1		1				
50	1	183920-79650	BOLT, BATTERY		2		2				
51	1	121750-59890	BAND, 140		2		2				
52	1	183251-79560	CABLE, +		1		1				
53	1	183920-79560	CABLE, -		1		1				
54	1	183251-79570	CABLE (-)		1		1				
55	1	26106-060122	BOLT, M6X 12 PLATED		2		2				
56	1	183366-95240	SPONGE		1		1				
57	1	183366-95300	SPONGE		1		1				
58	1	183294-95350	SEAT ASSY		1		1				
65	1	183294-95400	CAP ASSY		1		1				
68	1	183366-95500	SPONGE ASSY		1		1				
79	1	183366-95520	SPONGE ASSY		1		1				
82	1	183366-95530	SPONGE ASSY		1		1				
85	1	183366-95550	SPONGE ASSY		1		1				
88	1	183366-95950	SEAT		1		1				
89	1	183366-95680	WOOL, GLASS		1		1				
90	1	183366-95852	WOOL ASSY, GLASS		1		1				

Fig.14. GENERATOR

(A)=EP1700/2000
 (B)=EP1700/2000S
 (C)=EP2700/3100

(D)=EP2700/3100S
 (E)=
 (F)=

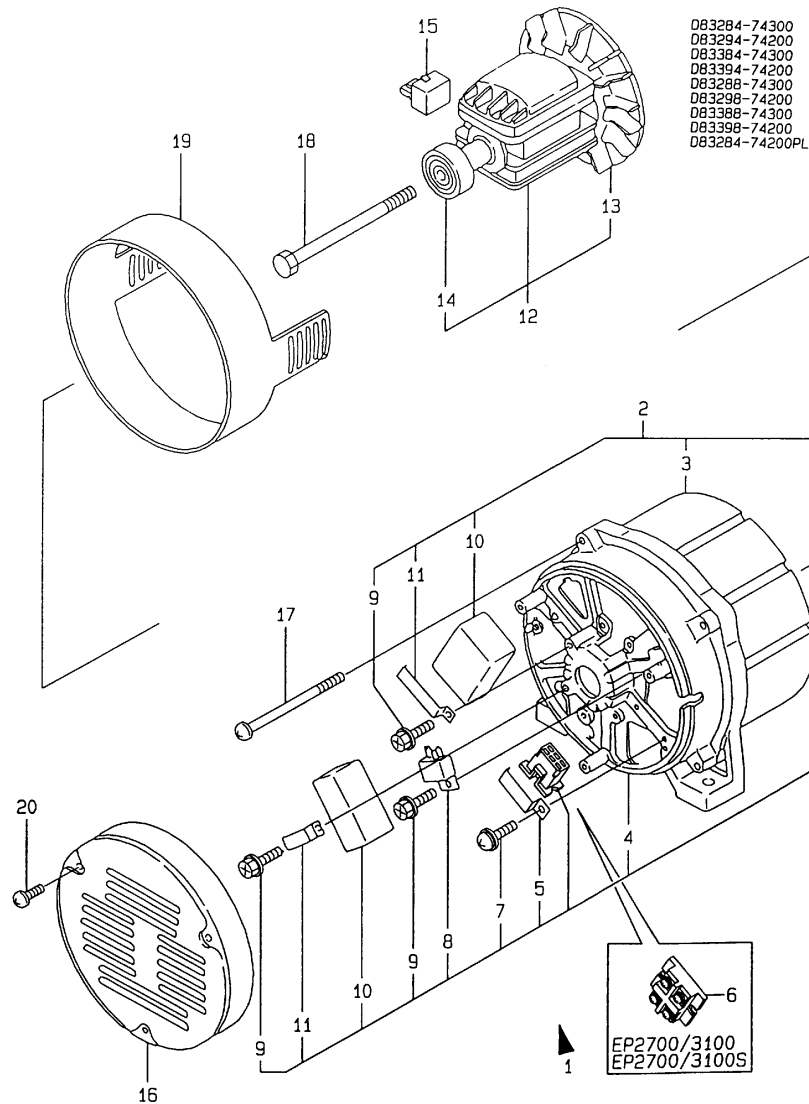

No.	Lev.	Parts No.	Description	Q'ty						I	R
				(A)	(B)	(C)	(D)	(E)	(F)		
1A	1	183284-74050	GENERATOR, 2.0KVA 50	1	1						1
1B	1	183288-74050	GENERATOR, 2.0KVA 60	1	1						2
1C	1	183384-74050	GENERATOR, 3.0KVA			1	1				3
1D	1	183388-74050	GENERATOR, 3.0KVA			1	1				4
2A	2	183730-74200	STATOR ASSY	1	1						1
2B	2	183740-74200	STATOR ASSY	1	1						2
2C	2	183830-74200	STATOR ASSY			1	1				3
2D	2	183840-74200	STATOR ASSY			1	1				4
3A	3	183730-74290	STATOR	1	1						1
3B	3	183740-74290	STATOR	1	1						2
3C	3	183830-74290	STATOR			1	1				3
3D	3	183840-74290	STATOR			1	1				4
4	3	183740-74250	COVER, REAR	1	1	1	1				
5	3	183740-74310	CLAMP	1	1						
6	3	183620-74270	TERMINAL			1	1				
7	3	183350-74380	SCREW, M4X14	1	1	1	1				
8	3	183210-74470	RECTIFIER	1	1	1	1				
9	3	183620-74310	SCREW M 5X10	3	3	3	3				
10	3	183740-74170	CONDENSER	2	2	2	2				
10-1	3	183294-74160	CONDENSER (B=*1999.08)		2		2				N
10A	4	183294-74170	CONDENSER, 350V (B=*1996.08)		2		2				W
10B	4	183294-74180	CLAMP (B=*1996.08)		2		2				W
11	3	183740-74180	CLAMP (B=*1996.08)	2	2	2	2				Z
12A	2	183741-74351	ROTOR ASSY	1	1						
12B	2	183840-74351	ROTOR ASSY			1	1				
13	3	183740-74360	FAN	1	1	1	1				
14	3	183740-74370	BEARING	1	1	1	1				
15	3	183294-74080	RECTIFIER, ROTOR	2	2	2	2				
16	1	183284-74400-1	COVER	1		1					
17A	1	183262-74410	BOLT, THROUGH M6X90	4	4						
17B	1	183362-74410	BOLT, THROUGH M6X110			4	4				
18A	1	26116-081902	BOLT, M8X190 PLATED	1	1						
18B	1	183382-74430	BOLT, M10X188			1	1				
19A	1	183262-74090	BAND, GENERATOR	1							
19B	1	183362-74090	BAND			1					
20	1	26557-040082	SCREW, M4X 8	3	3						

Remarks

- (1) ONLY FOR EP1700/1700S.
- (2) ONLY FOR EP2000/2000S.
- (3) ONLY FOR EP2700/2700S.
- (4) ONLY FOR EP3100/3100S.

Fig.15. PANEL(EP1700/2000/2700/3100)

(A)=EP1700/2000
(B)=EP1700/2000S
(C)=EP2700/3100

(D)=EP2700/3100S
(E)=
(F)=

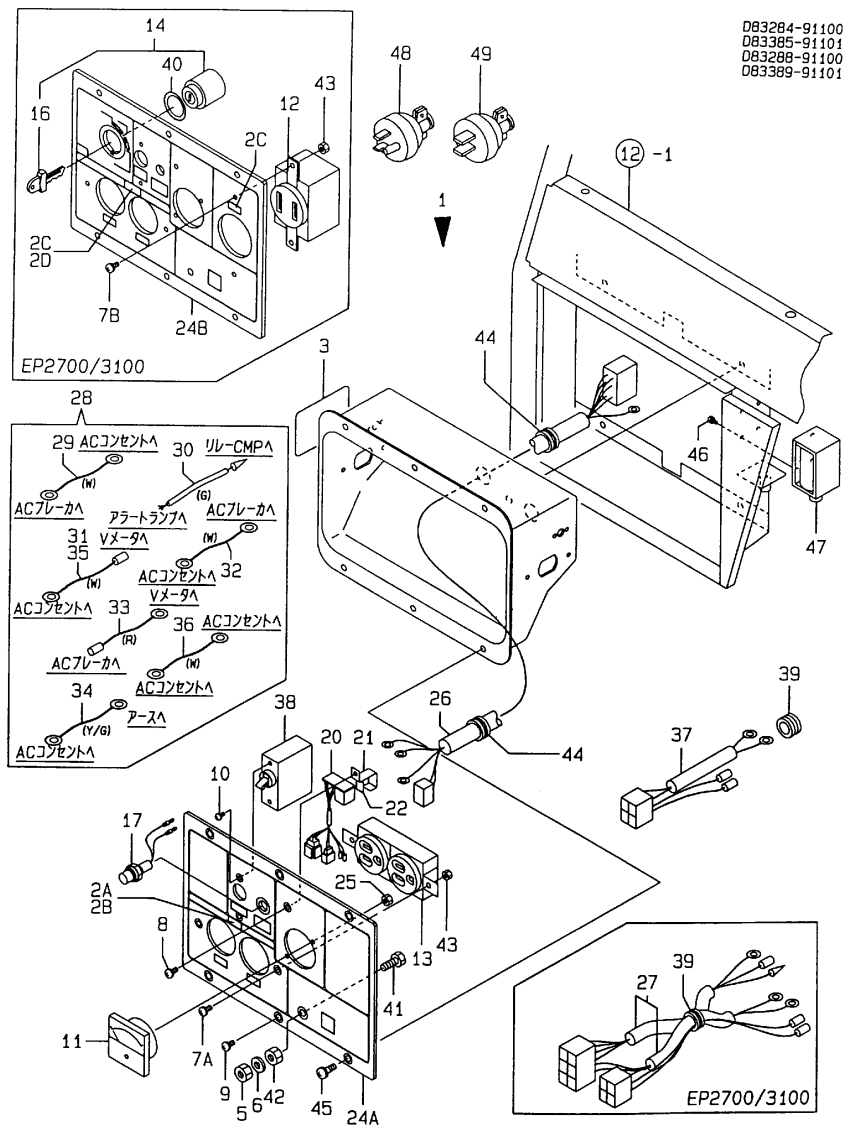

No.	Lev.	Parts No.	Description	Q'ty						I	R
				(A)	(B)	(C)	(D)	(E)	(F)		
1A	1	183284-91050	BOX ASSY, PANEL	1							1
1B	1	183288-91050	BOX ASSY, PANEL	1							2
1C	1	183385-91051	BOX ASSY, PANEL			1					3
1D	1	183389-91051	BOX ASSY, PANEL				1				4
2A	2	183284-07410	LABEL, AMPERE	1							1
2B	2	183284-07400	LABEL, AMPERE	1							2
2C	2	183394-07400	LABEL, AMPERE				2				3
2D	2	183384-07400	LABEL, AMPERE				1				4
3	2	183730-07490	SHEET	1		1					
5	2	183210-08810	NUT	1		1					
6	2	183350-55130	WASHER	1		1					
7A	2	183976-91080	SCREW, M4X10	2							
7B	2	183976-91080	SCREW, M4X10				4				
8	2	183976-91080	SCREW, M4X10	1		1					
9	2	183896-91090	SCREW, M5X10	2		2					
10	2	183976-91090	SCREW, M3X5	2		2					
11	2	183730-91210	REGULATOR, VOLTAGE	1		1					
12	2	183830-91320	SOCKET, 30A				1				
13	2	183920-91320	SOCKET, 125VX2	1		1					
14	2	183920-91450	SWITCH ASSY, KEY				1				
16	3	183920-91280	KEY, STARTER SWITCH				1				
17	2	183284-91501	LAMP ASSY, ALERT	1		1					
20	2	183284-91600	RELAY ASSY	1		1					
21	2	183284-91680	HOLDER	1		1					
22	2	183284-91690	CUSHION	1		1					
24A	2	183284-91900	BOARD, PANEL	1							
24B	2	183285-91901	BOARD, PANEL				1				
25	2	183925-91990	NUT, LOCK	2		2					
26A	2	183284-95500	HARNESS, WIRE	1							
26B	2	183384-95501	HARNESS, WIRE				1				
27	2	183285-95600	HARNESS, WIRE				1				
28A	2	183284-95810	HARNESS ASSY, WIRE	1							
28B	2	183384-95810	HARNESS ASSY, WIRE				1				
29	3	183284-95620	HARNESS, WIRE	2							
30	3	183284-95630	HARNESS, WIRE	2		2					
31	3	183284-95670	HARNESS, WIRE	1		1					
32	3	183284-95820	HARNESS, WIRE	1		2					
33	3	183284-95830	HARNESS, WIRE	1		1					
34	3	183284-95860	HARNESS, WIRE	1		1					
35	3	183384-95820	HARNESS, WIRE				1				
36	3	183384-95830	HARNESS, WIRE				2				
37	2	183284-95940	HARNESS, WIRE	1							
38A	2	183000-96400	BREAKER, AC 17.5A	1							1
38B	2	183000-96540	BREAKER, AC 20A	1							2
38C	2	183000-96560	BREAKER, AC 27A				1				3
38D	2	183000-96520	BREAKER, AC 30A				1				4
39	2	183625-98040	GROMMET	1		1					
40	2	23414-220029	GASKET, 22X1.0				1				
41	2	26113-060162	BOLT, M6X 16	1		1					
42	2	26753-060002	NUT, LOCK M6	1		1					
43	2	26757-040002	NUT, LOCK M4	2		4					

Remarks

- (1) ONLY FOR EP1700.
- (2) ONLY FOR EP2000.
- (3) ONLY FOR EP2700.
- (4) ONLY FOR EP3100.

Fig.15. PANEL(EP1700/2000/2700/3100)

(A)=EP1700/2000
 (B)=EP1700/2000S
 (C)=EP2700/3100

(D)=EP2700/3100S
 (E)=
 (F)=

No.	Lev.	Parts No.	Description	Q'ty						I	R
				(A)	(B)	(C)	(D)	(E)	(F)		
44	2	29311-122000	GROMET, 12.0X2	2		2					
45	1	183896-91090	SCREW, M5X10	4		4					
46	1	183620-91310	SCREW M 3X 10	4		4					
47	1	183266-91690	DC.SOLENOID(12V)	1		1					
48	1	183720-91750	PLUG, 125VX15A	2		2					
49	1	183392-91750	PLUG, 30A-250V	1		1					

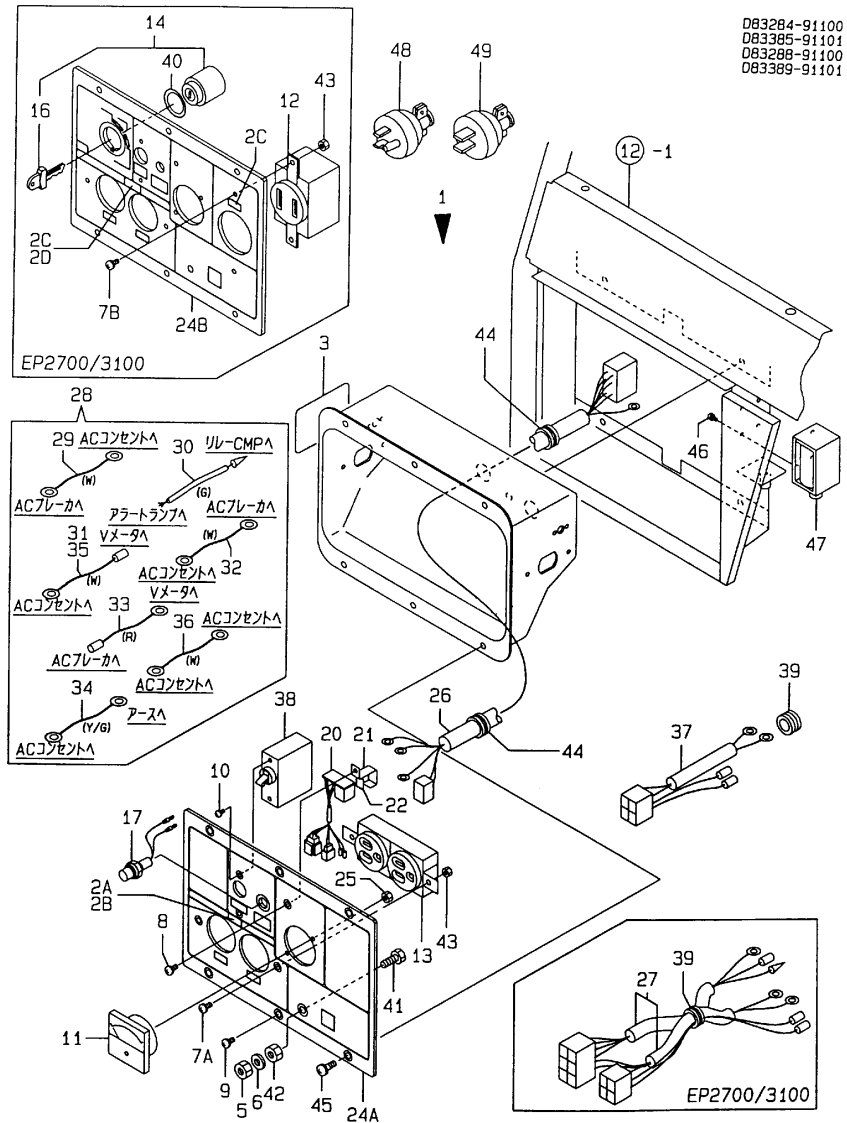

Remarks
 (1) ONLY FOR EP1700.
 (2) ONLY FOR EP2000.
 (3) ONLY FOR EP2700.
 (4) ONLY FOR EP3100.

Fig.16. PANEL(EP1700/2000/2700/3100S)

(A)=EP1700/2000 (D)=EP2700/3100S
 (B)=EP1700/2000S (E)=
 (C)=EP2700/3100 (F)=

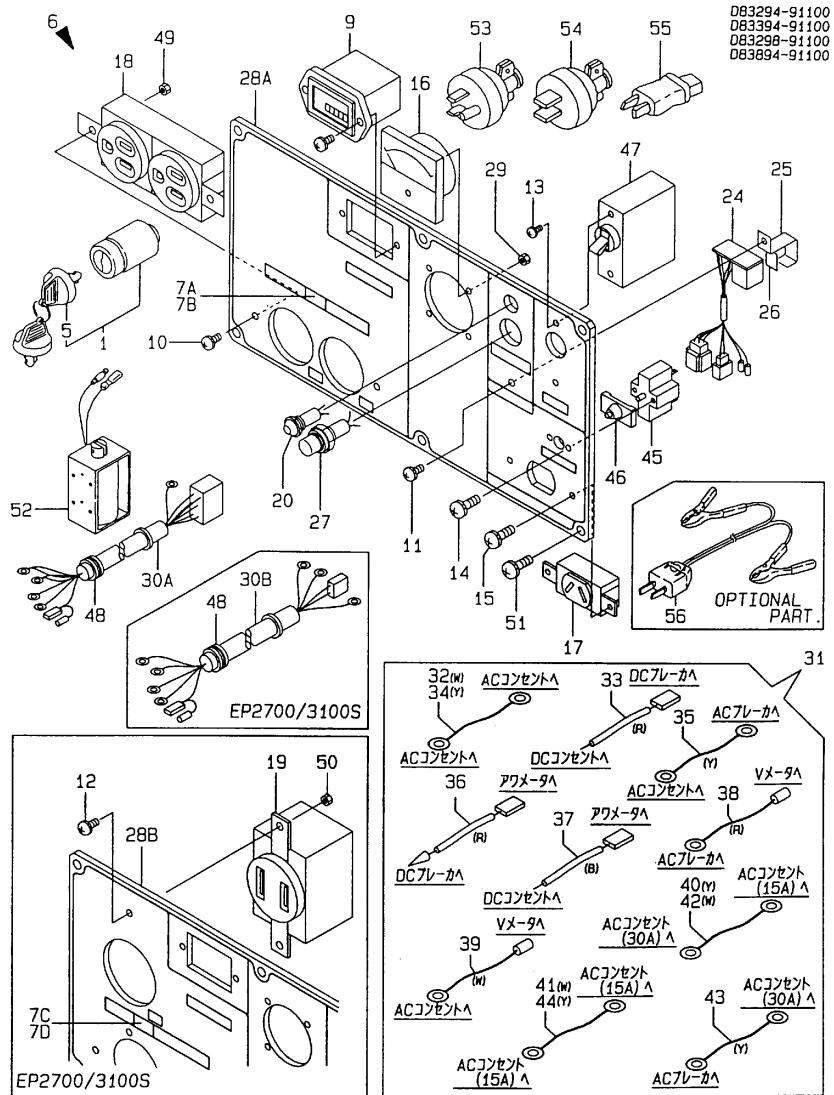

No.	Lev.	Parts No.	Description	Q'ty						I	R
				(A)	(B)	(C)	(D)	(E)	(F)		
1	1	160797-77250	SWITCH ASSY, KEY		1		1				
5	2	160797-77270	KEY, REVERSE		1		1				
6A	1	183294-91050	PANEL ASSY		1						1
6B	1	183298-91050	PANEL ASSY		1						2
6C	1	183394-91050	PANEL ASSY						1		3
6D	1	183894-91050	PANEL ASSY						1		4
7A	2	183284-07410	LABEL, AMPERE		1						1
7B	2	183284-07400	LABEL, AMPERE		1						2
7C	2	183394-07400	LABEL, AMPERE						1		3
7D	2	183384-07400	LABEL, AMPERE						1		4
9	2	183367-91070	METER, HOUR		1		1				
10	2	183976-91080	SCREW, M4X10		2		2				
11	2	183976-91080	SCREW, M4X10		1		1				
12	2	183976-91080	SCREW, M4X10						2		
13	2	183976-91090	SCREW, M3X5		2		2				
14	2	183976-91090	SCREW, M3X5		2		2				
15	2	183976-91090	SCREW, M3X5		2		2				
16	2	183730-91210	REGULATOR, VOLTAGE		1		1				
17	2	183825-91250	CONSENT		1		1				
18	2	183920-91320	SOCKET, 125VX2		1		1				
19	2	183830-91320	SOCKET, 30A						1		
20	2	183794-91510	LAMP ASSY, PILOT		1		1				
24	2	183294-91600	RELAY ASSY		1		1				
25	2	183284-91680	HOLDER		1		1				
26	2	183284-91690	CUSHION		1		1				
27	2	183131-91701	LAMP, ALARM		1		1				
28A	2	183294-91900	BOARD, PANEL		1						
28B	2	183394-91900	BOARD, PANEL						1		
29	2	183925-91990	NUT, LOCK		2		2				
30A	2	183294-95500	HARNESS, WIRE		1						
30B	2	183394-95500	HARNESS, WIRE							1	
31A	2	183294-95810	HARNESS ASSY, WIRE		1						
31B	2	183394-95810	HARNESS ASSY, WIRE							1	
32	3	183284-95620	HARNESS, WIRE		1						
33	3	183294-95670	HARNESS, WIRE		1				1		
34	3	183284-95680	HARNESS, WIRE		1						
35	3	183294-95820	HARNESS, WIRE		1						
36	3	183294-95850	HARNESS, WIRE		1		1				
37	3	183294-95860	HARNESS, WIRE		1		1				
38	3	183294-95830	HARNESS, WIRE		1		1				
39	3	183294-95900	HARNESS, WIRE		1		1				
40	3	183888-95270	HARNESS, WIRE						1		
41	3	183284-95820	HARNESS, WIRE						1		
42	3	183384-95820	HARNESS, WIRE						1		
43	3	183294-95870	HARNESS, WIRE						1		
44	3	183384-95890	HARNESS, WIRE						1		
45	2	183284-96310	BREAKER, DC		1		1				
46	2	183284-96320	CAP, BREAKER		1		1				
47A	2	183000-96400	BREAKER, AC 17.5A		1						1
47B	2	183000-96540	BREAKER, AC 20A		1						2
47C	2	183000-96560	BREAKER, AC 27A						1		3

Remarks

- (1) ONLY FOR EP1700S.
- (2) ONLY FOR EP2000S.
- (3) ONLY FOR EP2700S.
- (4) ONLY FOR EP3100S.
- (5) OPTIONAL PART.

Fig.16. PANEL(EP1700/2000/2700/3100S)

(A)=EP1700/2000
 (B)=EP1700/2000S
 (C)=EP2700/3100

(D)=EP2700/3100S
 (E)=
 (F)=

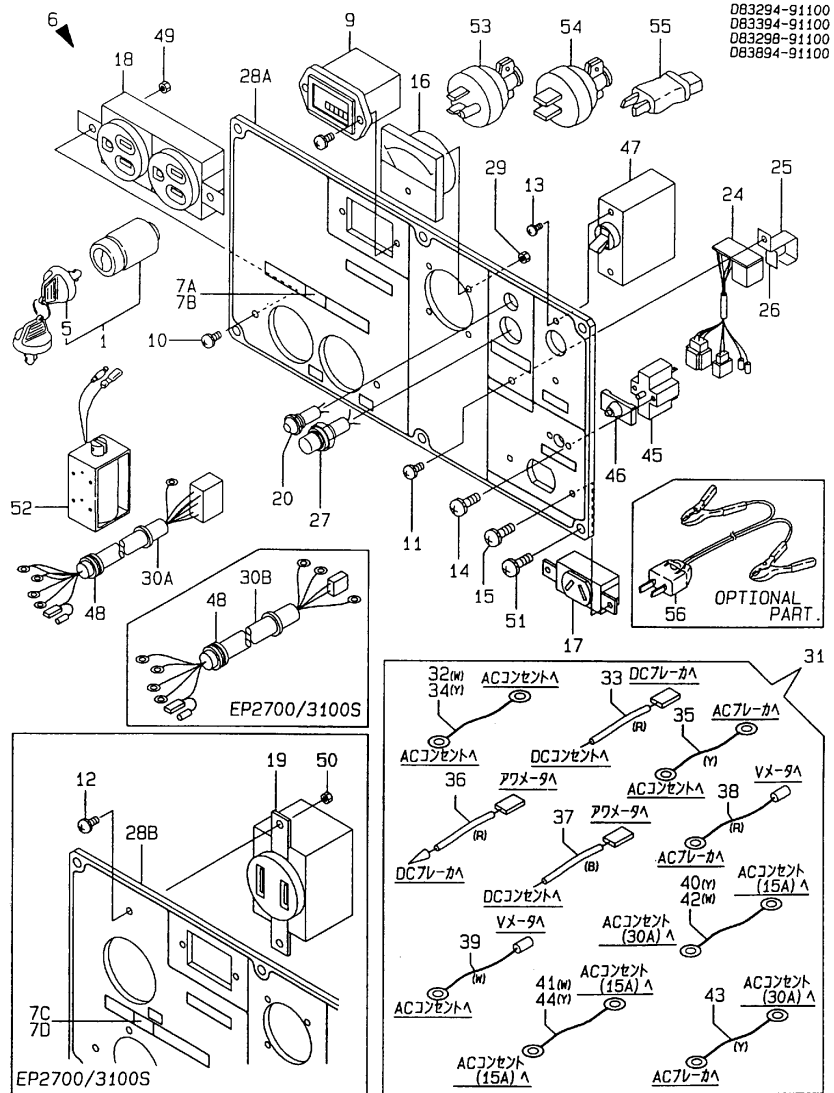

No.	Lev.	Parts No.	Description	Qty						I	R
				(A)	(B)	(C)	(D)	(E)	(F)		
47D	2	183000-96520	BREAKER, AC 30A				1				4
48	2	183625-98040	GROMMET		1		1				
49	2	26757-040002	NUT, LOCK M4		2		2				
50	2	26757-040002	NUT, LOCK M4				2				
51	1	183896-91090	SCREW, M5X10		6		6				
52	1	183250-91690	DC.SOLENOID(12V.10W)		1		1				
53	1	183720-91750	PLUG, 125VX15A		1		1				
54	1	183392-91750	PLUG, 30A-250V				1				
55	1	183720-91790	PLUG, DC12V		1		1				
56	1	183210-91880	CABLE, CHARGING		1		1				5

- Remarks
- (1) ONLY FOR EP1700S.
 - (2) ONLY FOR EP2000S.
 - (3) ONLY FOR EP2700S.
 - (4) ONLY FOR EP3100S.
 - (5) OPTIONAL PART.

Parts No. Index

Parts No.	Fig. No.	Ref. No.
101147-12550	12	14
	13	45
101158-11180	2	8 B
101504-55051	9	11
103338-32570	6	12
	11	58
103854-01221	5	8
103854-55220	9	14
105010-11490	2	27 B
		28 B
105015-55040	9	3 B
105225-01240	1	8 B
105225-66990	6	56
105425-01690	1	17
	13	1
105546-51020	8	2
105546-51330	8	14
105990-07920	13	2
106990-44660	9	35
		39
		43
114250-01200	1	5 A
114250-01210	1	6 A
114250-01220	1	7 A
114250-01250	1	9 A
114250-01340	1	10 A
	11	46 A
114250-01380	1	11 A
	11	47 A
114250-01412	1	12 A
	11	48 A
114250-01800	1	21
114250-01830	1	26
114250-01840	1	27
	11	50
114250-02030	1	44
114250-02100	1	15 A
114250-02113	1	45 A
114250-02200	1	50 A
114250-02210	1	51 A
114250-03591	2	41 B
114250-03640	2	44
114250-07350	11	6
114250-11020	2	1 A
114250-11101	2	5 A
114250-11113	2	6 A
114250-11120	2	7 A
114250-11180	2	8 A
114250-11240	2	20
		25

Parts No.	Fig. No.	Ref. No.
114250-11290	2	11
114250-11310	2	38
	11	54
114250-11340	2	14 A
	11	52 A
114250-11460	2	15
	11	53
114250-11600	2	17
114250-11651	2	18
114250-11900	2	29
114250-11951	2	39 B
114250-12010	3	1 A
114250-12200	3	2 A
	11	55 A
114250-12210	3	3
	11	56
114250-12520	3	7
114250-12530	3	8 A
114250-12550	3	11
114250-12560	3	9
114250-12580	3	10
114250-13200	4	1
	11	57
114250-14200	5	5
114250-14260	5	6
114250-14450	5	7 A
114250-21550	5	16
114250-22302	5	29 A
114250-23200	5	34
114250-23220	5	35
114250-23250	5	36
114250-32010	6	1
114250-32070	6	6
114250-35070	6	15
114250-35150	1	32
114250-45211	7	2 A
114250-45300	7	4
114250-45310	7	6
114250-45330	7	9
114250-51080	8	3
114250-51150	8	4
114250-51160	8	5
114250-51300	8	11
114250-51340	8	15
114250-51600	8	17
114250-51640	8	18
114250-51650	8	19
114250-53001	8	23 A
114250-53080	8	26
114250-53120	8	27

Parts No.	Fig. No.	Ref. No.
114250-53130	8	28
114250-53140	8	29
114250-53210	8	30
114250-53300	8	31
114250-53331	8	34
114250-53400	8	35
114250-59800	8	42 B
114250-66200	6	34
114250-66440	6	41
114250-66550	6	51 B
114250-76590	7	40 A
114250-76600	7	41
114250-76610	7	42
	9	29
114250-92101	11	34
114250-92130	11	35
114250-92311	11	42 A
114250-92350	11	43 A
114250-92600	11	26
114252-13950	4	7
114252-66120	6	33
114252-66252	6	38
114260-76050	7	23 A
114260-76250	7	24 A
114260-76520	7	25 A
114262-21600	5	19 A
114270-61520	6	25
114350-01200	1	5 B
114350-01210	1	6 B
114350-01220	1	7 B
114350-01250	1	9 B
114350-01340	1	10 B
	11	46 B
114350-01380	1	11 B
	11	47 B
114350-01412	1	12 B
	11	48 B
114350-01700	1	3
114350-02100	1	15 B
114350-02113	1	45 B
114350-02200	1	50 B
114350-02210	1	51 B
114350-11101	2	5 B
114350-11113	2	6 B
114350-11120	2	7 B
114350-11340	2	14 B
	11	52 B
114350-11470	2	16
114350-12011	3	1 B
114350-12201	3	2 B

Parts No.	Fig. No.	Ref. No.
114350-12201	11	55 B
114350-14450	5	7 B
114350-22301	5	29 B
114350-45320	7	7
114350-45340	7	10
114350-59800	8	42 D
114350-76590	7	40 B
114350-92301	11	41 A
114350-92311	11	42 B
114350-92350	11	43 B
114351-78250	10	29
114351-78750	10	30
114351-78760	10	31
114360-45101-4	7	1 C
114361-92300	11	41 B
114362-21600	5	19 B
114362-77010	10	1
114370-07050	11	4
114370-45350	7	22
114650-12350	3	4
114658-13800	4	12
114770-61600	6	28
114770-61610	6	26
114770-66010	6	30 A
114770-66550	6	51 A
114780-21400	5	15
114780-45100-2	7	1 A
114870-11020	2	1 B
114870-45200	7	2 B
114870-53000	8	23 B
114870-66010	6	30 B
114880-76050	7	23 B
114880-76250	7	24 B
114880-76510	7	25 B
114881-21590	5	17 B
114883-66060	6	31
119260-11370	2	27 A
		28 A
121750-59890	12	20
	13	51
124550-51350	8	16
124722-59050	9	41
124950-01250	1	8 A
129100-61850	2	49
160110-01870	1	28
160110-02220	1	46
		47 B
160210-02220	1	47 A
160260-76520	7	26 A
160260-76530	7	27 A

Parts No. Index

Parts No.	Fig. No.	Ref. No.
160260-76540	7	28 A
160260-76550	7	29
160260-76560	7	30 A
160260-76580	7	32
160260-76590	7	33 A
160260-76600	7	34
160260-76620	7	36 A
160260-76630	7	37 A
160290-76570	7	31
160330-92730	11	27
160393-55050	9	10
160670-66350	2	50
160710-01760	1	18 A
160710-55061	9	3 A
160710-55100	9	12
160710-78710	10	32
160797-77250	16	1
160797-77270	16	5
160810-55480	13	27
160810-76520	7	26 B
160810-76540	7	28 B
160810-76580	7	33 B
160810-76620	7	36 B
160810-76630	7	37 B
160840-76530	7	27 B
160840-76560	7	30 B
160910-01740	1	18 B
160970-77350	10	22
170001-07230	11	7
171008-03990	9	42
171022-39470	1	35
181130-76680	7	38
181130-76700	7	39
183000-96400	15	38 A
	16	47 A
183000-96520	15	38 D
	16	47 D
183000-96540	15	38 B
	16	47 B
183000-96560	15	38 C
	16	47 C
183101-08550	13	21
183131-91701	16	27
183210-07390	11	23
183210-08810	13	22
	15	5
183210-74470	14	8
183210-91880	16	56
183250-01450	1	13 A
183250-03410	2	34

Parts No.	Fig. No.	Ref. No.
183250-03450	2	35
183250-03510	2	36 A
183250-03550	2	37
183250-03601	2	41 A
183250-07110	11	3
183250-07260	11	12
183250-07450	11	17
183250-07480	11	18
183250-08150	12	2 A
183250-08160	12	3
183250-08220	13	13
183250-11951	2	39 A
183250-21350	5	14 A
183250-39450	1	33
183250-51200	8	6 A
183250-55320	9	20 B
183250-59800	8	42 A
183250-66321	6	44
183250-66331	6	39
		45
183250-66341	6	46
183250-66361	6	48
183250-66410	6	40
183250-66511	6	42
183250-91690	16	52
183251-79560	13	52
183251-79570	13	54
183252-07870	11	21 A
		21 C
183256-78300	10	24
183256-78310	10	25
183262-07870	11	21 B
		21 D
183262-74090	14	19 A
183262-74410	14	17 A
183262-92350	11	44 A
183266-08150	13	9 A
183266-08240	13	14 A
183266-08360	13	17
183266-13601	4	11 A
183266-21590	5	17 A
183266-45110	7	1 B
183266-45360	7	11
183266-45460	7	13 A
183266-66110	6	32 B
183266-66210	6	35
183266-66230	6	36
183266-91690	15	47
183267-07230	11	19
183267-08100-1	13	6

Parts No.	Fig. No.	Ref. No.
183267-08240	13	15 A
183267-08910	13	24
183267-66240	6	37
183267-66350	6	29
183267-91390	10	26
183284-07351	11	13
183284-07370	11	15
183284-07400	15	2 B
	16	7 B
183284-07410	15	2 A
	16	7 A
183284-07750	11	20 A
183284-07900	11	24
183284-08010-2	12	1 A
183284-08250	12	4
183284-13050	4	4 A
183284-13500	4	5
183284-13550	4	6
183284-55300	9	20 A
183284-55311	9	23 A
183284-55321	9	24 A
183284-55331	9	25
183284-55341	9	26
183284-55400	9	28 A
183284-59010	9	34 A
183284-59020	9	38
183284-59060	9	46 A
183284-74050	14	1 A
183284-74400-1	14	16
183284-91050	15	1 A
183284-91501	15	17
183284-91600	15	20
183284-91680	15	21
	16	25
183284-91690	15	22
	16	26
183284-91900	15	24 A
183284-95500	15	26 A
183284-95620	15	29
	16	32
183284-95630	15	30
183284-95670	15	31
183284-95680	16	34
183284-95810	15	28 A
183284-95820	15	32
	16	41
183284-95830	15	33
183284-95860	15	34
183284-95940	15	37
183284-96310	16	45

Parts No.	Fig. No.	Ref. No.
183284-96320	16	46
183285-66420	6	32 C
183285-91901	15	24 B
183285-95600	15	27
183288-07750	11	20 B
183288-74050	14	1 B
183288-91050	15	1 B
183292-07210	11	16
183294-07750	11	20 C
183294-08120	13	8
183294-74080	14	15
183294-74160	14	10 -1
183294-74170	14	10 A
183294-74180	14	10 B
183294-91050	16	6 A
183294-91600	16	24
183294-91900	16	28 A
183294-95300	7	45
183294-95350	13	58
183294-95400	13	65
183294-95500	16	30 A
183294-95670	16	33
183294-95810	16	31 A
183294-95820	16	35
183294-95830	16	38
183294-95850	16	36
183294-95860	16	37
183294-95870	16	43
183294-95900	16	39
183298-07750	11	20 D
183298-91050	16	6 B
183350-01450	1	13 B
183350-03510	2	36 B
183350-08150	12	2 B
183350-13512	4	4 C
183350-21350	5	14 B
183350-51200	8	6 B
183350-55110	9	15
183350-55120	9	16
	12	6
183350-55130	6	57
	9	17
	13	25
	15	6
183350-55260	9	19
183350-59060	9	46 C
183350-59800	8	42 C
183350-66420	6	32 A
183350-74380	14	7
183350-77400	10	23

Parts No. Index

Parts No.	Fig. No.	Ref. No.
183350-79510	12	15
	13	46
183350-79550	12	21
183350-79560	12	22
183350-79610	12	24
183350-79630	12	18
	13	49
183352-07870	11	21 E
		21 G
183362-07870	11	21 F
		21 H
183362-74090	14	19 B
183362-74410	14	17 B
183362-92350	11	44 B
183366-07240	11	25
183366-07251	11	14
183366-07280	11	9
183366-07290	11	8
183366-08051-1	13	3
183366-08080-4	13	4
183366-08091-4	13	5
183366-08111-4	13	7
183366-08150	13	9 B
183366-08170-4	13	10
183366-08180	13	11
183366-08190-1	13	12
183366-08290	1	29
	13	16
183366-08351	1	30
183366-08400	13	18
183366-08460	13	19 B
183366-08461	13	19 A
183366-08470	13	20
183366-08900	13	23
183366-12530	3	8 B
183366-12590	3	12
183366-13300	4	4 B
183366-13601	4	11 B
183366-21590	5	17 C
183366-39460	1	34
183366-45111	7	1 D
183366-45220	7	3
183366-45300	7	5
183366-45320	7	8
183366-45410	7	12
183366-45460	7	13 B
183366-45600	7	14
183366-55120	9	22
183366-55150	9	13 B
183366-55210	13	26

Parts No.	Fig. No.	Ref. No.
183366-59010	9	34 B
183366-59330	9	44
183366-59341	9	45 A
183366-59351	9	45 B
183366-95240	13	56
183366-95300	13	57
183366-95500	13	68
183366-95520	13	79
183366-95530	13	82
183366-95550	13	85
183366-95680	13	89
183366-95852	13	90
183366-95950	13	88
183367-91070	16	9
183382-74430	14	18 B
183384-07250	11	5
183384-07400	15	2 D
	16	7 D
183384-08010-1	12	1 B
183384-08350-1	12	5
183384-55311	9	23 B
183384-55321	9	24 B
183384-55401	9	28 B
183384-59010	9	34 C
183384-74050	14	1 C
183384-95501	15	26 B
183384-95810	15	28 B
183384-95820	15	35
	16	42
183384-95830	15	36
183384-95890	16	44
183385-07200	11	2
183385-07551	11	22 A
183385-07750	11	20 E
183385-91051	15	1 C
183388-74050	14	1 D
183389-07550	11	22 B
183389-07750	11	20 F
183389-91051	15	1 D
183392-08230	13	14 B
183392-08250	13	15 B
183392-91750	15	49
	16	54
183394-07400	15	2 C
	16	7 C
183394-07750	11	20 G
183394-91050	16	6 C
183394-91900	16	28 B
183394-95500	16	30 B
183394-95810	16	31 B

Parts No.	Fig. No.	Ref. No.
183398-07750	11	20 H
183610-07230	11	10
183620-07230	11	11
183620-74270	14	6
183620-74310	14	9
183620-91310	15	46
183621-55150	9	13 C
183625-98040	15	39
	16	48
183671-13210	4	2
183671-59060	9	46 B
183720-55210	7	15
	9	18
	12	7
183720-91750	15	48
	16	53
183720-91790	16	55
183730-07490	15	3
183730-74200	14	2 A
183730-74290	14	3 A
183730-91210	15	11
	16	16
183740-74170	14	10
183740-74180	14	11
183740-74200	14	2 B
183740-74250	14	4
183740-74290	14	3 B
183740-74310	14	5
183740-74360	14	13
183740-74370	14	14
183741-74351	14	12 A
183794-91510	16	20
183825-91250	16	17
183830-74200	14	2 C
183830-74290	14	3 C
183830-91320	15	12
	16	19
183840-74200	14	2 D
183840-74290	14	3 D
183840-74351	14	12 B
183888-95270	16	40
183894-91050	16	6 D
183896-91090	15	9
		45
	16	51
183920-79560	12	23
	13	53
183920-79650	12	19
	13	50
183920-91280	15	16

Parts No.	Fig. No.	Ref. No.
183920-91320	15	13
	16	18
183920-91450	15	14
183925-55150	9	13 A
183925-91990	15	25
	16	29
183976-91080	15	7 A
		7 B
		8
	16	10
		11
		12
183976-91090	15	10
	16	13
		14
		15
194312-61810	13	28
194312-61840	13	30
194555-61820	13	29
22117-100000	1	36
22117-120000	13	31
22137-080000	6	27
	13	32
22137-140000	13	33
22190-160002	1	43 A
22213-080000	4	13
22217-080000	6	67
22252-000190	5	30 A
22252-000210	5	30 B
22272-000050	13	34
22312-030080	5	37
22312-030160	2	46
	6	13
22312-080120	1	37
22322-030200	6	23
		24
22351-020006	8	20
22351-030008	8	21
22351-030012	6	58
22351-040008	2	30
22360-060000	9	30
	12	8
22417-320250	13	35
22512-040120	5	20
23414-220029	15	40
23418-050000	6	59
24101-062050	1	48 A
24101-062060	1	48 B
24162-152112	1	49
24311-000180	1	20

Parts No. Index

Parts No.	Fig. No.	Ref. No.
24311-000180	11	49
24311-000400	9	31
24341-000150	9	21
24341-000224	6	16
	11	59
26013-080302	4	15
26014-060142	4	14 B
26014-080302	7	18
26022-050102	9	32
26023-030082	6	60
26106-060082	7	19
		43
26106-060102	12	25
26106-060122	7	20
		44
	9	33
	10	27
	13	55
26106-060142	7	17
26106-060162	4	14 C
	6	17
		50
26106-060202	2	51
	4	17
	6	63
26106-060252	1	38 A
	3	13
26106-060552	2	52
26106-080122	1	31
26106-080162	4	14 A
	12	9
26106-080202	13	36
26106-080252	13	37
26106-080302	12	26
26106-080352	1	38 B
26106-080452	2	31
	13	38 B
26106-080602	13	38 A
26106-100122	1	4
26106-100162	13	39
26106-100302	10	28
26106-100352	12	10
26106-100382	13	40
26106-100402	12	11
26113-060162	15	41
26116-060454	11	37
26116-080454	11	38
26116-081902	14	18 A
26216-080182	4	3
26226-060142	3	14

Parts No.	Fig. No.	Ref. No.
26226-060182	1	39
26226-060222	1	40
26226-060502	2	32
26226-060552	3	16
26347-060002	6	68
26366-060002	1	41
	2	33
		53
	3	15
	9	27
26366-080002	4	16
	12	27
	13	41
26366-100002	12	12
	13	42
26476-060142	2	54
	6	14
		61
	7	21 A
	10	33
26476-060202	6	62
	7	21 B
	10	34
26557-040082	1	42
	6	64
	14	20
26557-060142	7	16
26577-060142	10	35
26696-100002	6	65
	12	13
	13	43
26716-060002	11	39
26716-080002	11	40
26753-060002	15	42
26756-060002	2	21
		26
		55
26757-040002	15	43
	16	49
		50
26757-060002	6	66
26757-080002	6	69
27310-060001	2	9 B
28110-100120	11	31
28110-140170	11	32
28210-000150	11	33
29311-122000	15	44
43400-500490	1	43 B
	11	51
	13	44

Parts No.	Fig. No.	Ref. No.
714250-11570	2	9 A
714250-12560	3	5 A
714250-22502	5	23 A
714250-22542	5	42 A
714250-22550	5	48 A
714250-23600	5	38 A
714250-23610	5	52 A
714250-23620	5	54 A
714250-23703	5	31 A
714250-53101	8	22 A
714250-61501	6	18 A
714250-92602	11	45 A
714270-11660	2	22 A
714271-01560	1	1 A
714280-22580	5	46 A
714280-22620	5	40 A
714280-22720	5	21 A
714350-22502	5	23 B
714350-22542	5	42 B
714350-22550	5	48 B
714350-23600	5	38 B
714350-23610	5	52 B
714350-23620	5	54 B
714350-23704	5	31 B
714350-61501	6	18 B
714350-92602	11	45 B
714370-11660	2	22 B
714371-01560	1	1 B
714380-22580	5	46 B
714380-22620	5	40 B
714380-22720	5	21 B
714770-61700	6	7
714780-14580	5	1 A
714780-14581	5	1 A-1
714870-53100	8	22 B
714880-14580	5	1 B
783250-51701	8	1 A
783284-55700-1	9	1 A
783292-21700	5	9 A
783350-51701	8	1 B
783366-12560	3	5 B
783366-55700-1	9	1 B
783384-55700-1	9	1 C
783392-21700	5	9 B
7E4133-99290	11	28
X211416603	10	14
X211427501	10	18
X21142835	10	21
X21143215	10	7
X211445508	10	13

Parts No.	Fig. No.	Ref. No.
X21145312	10	6
X21145352	10	9
		15
X211456013	10	17
X21145867	10	20
X211461104	10	2
X211468005	10	19
X21147155	10	4
X211473008	10	8 -1
X211478006	10	16
X21148110	10	3
X21148313	10	11
X211489001	10	10
X211492108	10	5 -1
X21149314	10	12