

OCD10-M35203EN

# PREFACE

1. This Parts Catalog is the 1st edition of 3TN100L-TBZ Diesel Engine for TAKEUCHI IND..

Pub. No. : 000Y00D3523

Published : June, 1994

2. Model name

Engine model	Vehicle		Vehicle made by
	Products	Model name	
3TN100L-TBZ	EXCAVATOR	—	TAKEUCHI IND.

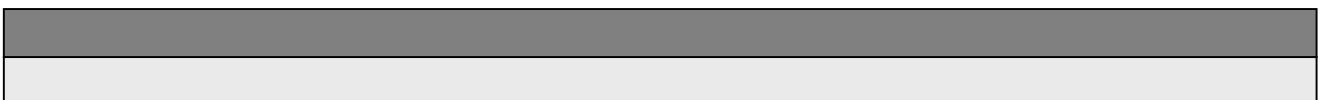

## Directions for the Parts Catalog.

1. This Parts Catalog shows both standard and optional parts.
2. Parts may change without prior notice.
3. The following is an example of the Parts Catalog format.

REF.	LEV.	PARTS NO.	DESCRIPTION	Q'TY						I	R
				(A)	(B)	(C)	(D)	(E)	(F)		
1	1	729595-51390	FUEL INJECTION PUMP	1	1	1	1	1			1
1-1	1	729595-51391	FUEL INJECTION PUMP	1	1	1	1	1		N	1
		(A=E00185) (B=E00200)									
3	2	26022-060162	SCREW M 6X 16	9	9	9	9	9			
3-1	2	26022-060162	SCREW M 6X 16	4	4	4	4	4		K	
		(A=E00156) (B=E00156) (C=E00156) (D=E00156) (E=E00156)									
4	2	129470-51040	CAMSHAFT	1	1	1	1	1			
5	2	122710-51050	BEARING, ROLLER	2	2	2	2	2			
6	2	129470-51060	RETAINER	1	1	1	1	1			

Remarks
(1) BOOST COMPEMSATOR TYPE. OPTIONAL PART, TO E00155,(4JH-DT, 4JH-DTZ

### ① Ref. No.

The Ref. No. listed may not be in accordance with the illustration Ref. No.

(Ex.) Illustration No.

List Ref No.

1

1

(Before change)

1-1

(After change)

For interchangeable symbols N, R and K, illustrations for new parts may be abbreviated.

### ② Lev. (Level)

Level indication

The numbers below indicate the level of relativity towards the main part.

1 ----- Main parts (Assembly parts)

2 ----- Sub component included in " 1 ".

3 ----- Sub component included in " 2 ".

Note) Parts that are not for sale are partially illustrated but not listed.

### ③ Interchangeability Symbol

When a part change takes place, one of the following interchangeability symbols is indicated beside the part.

Symbol	Interchangeability	Contents note
N	Old $\begin{matrix} \leftarrow \text{Yes} \\ \text{No} \rightarrow \end{matrix}$ New	New Part is interchangeable for Old Part but Old Part is not interchangeable for New Part.
Q	Old $\begin{matrix} \leftarrow \text{No} \\ \text{Yes} \rightarrow \end{matrix}$ New	New Part is not interchangeable for Old Part but Old Part is interchangeable for New Part.
R	Old $\begin{matrix} \leftarrow \text{Yes} \\ \text{Yes} \rightarrow \end{matrix}$ New	New/ Old Parts are both interchangeable.
S	Old $\begin{matrix} \leftarrow \text{No} \\ \text{No} \rightarrow \end{matrix}$ New	New/ Old Parts are both not interchangeable.
W		Part newly added.
Z		Part discontinued.
F		Not interchangeable by a single part but interchangeable together with related parts.
K		Changes only for used parts quantities.

### ④ Effective Machine No.

When a part changes, the effective Machine No. will be indicated in the (A)-(F) column.

Product Symbol	Product No.	Product Symbol	Product No.
C	Clutch No. Compressor No.	F	Machine No. (Agricultural Equip.)
D	Drive No.	M	Machine No.
E	Engine No.		

Note 1) A date may follow the symbol. (Ex.) 1996.01

Note 2) "XXXXX" and "ZZZZZ" are for parts that could not be predicted or for engine models that could not be identified.

Note 3) (A=E00185) is the E (Engine Serial Number) for the column (A) model (in this case 4JH-DT) after the parts design change.

### ⑤ Remarks

Figures or alphabets (symbols) are entered in the remarks column.

The comments (remarks) on parts that are indicated at the bottom of the illustration are the same symbols as those stated above.

# Contents

Fig. No. Fig. Name

3TN100L-TBZ

1. CYLINDER BLOCK
2. GEAR HOUSING
3. FLYWHEEL HOUSING & OIL SUMP
4. CYLINDER HEAD & BONNET
5. SUCTION MANIFOLD & AIR CLEANER
6. EXHAUST MANIFOLD & SILENCER
7. CAMSHAFT & DRIVE GEAR
8. CRANKSHAFT & PISTON
9. LUB. OIL SYSTEM
10. OIL COOLER CASE
11. COOLING WATER SYSTEM
12. FUEL INJECTION PUMP
13. FUEL INJECTION PIPE
14. FUEL OIL PIPE
15. GOVERNOR
16. STARTING MOTOR
17. GENERATOR
18. TOOL & GASKET SET(OPTIONAL)

Fig. No. Fig. Name

# Fig.1. CYLINDER BLOCK

Y0003523  
3TN100L-TBZ

D19000-01110  
D19000-02100

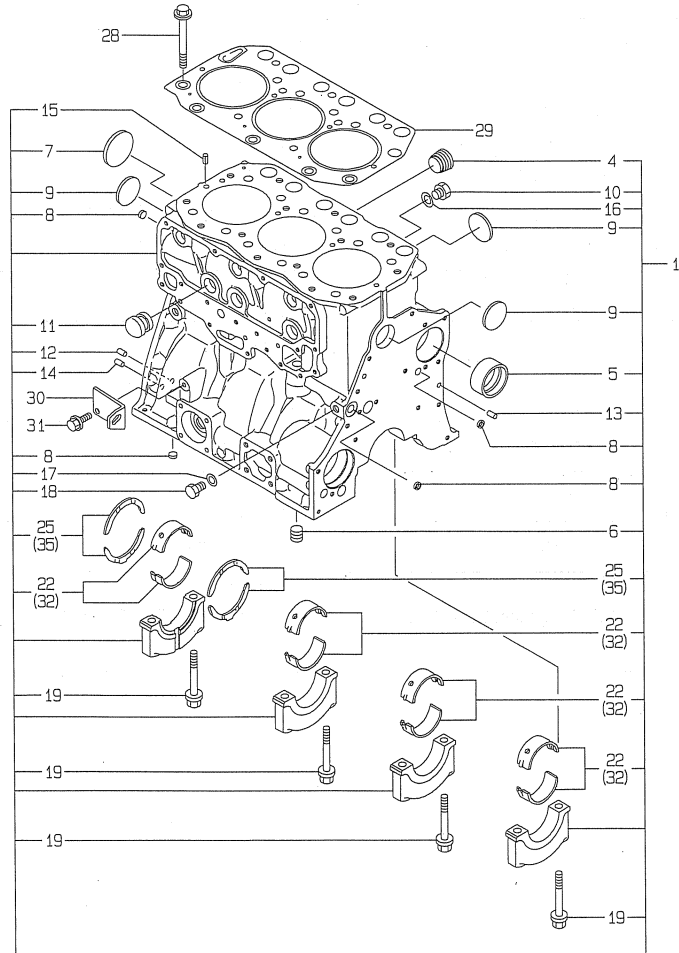

(A)=3TN100L-TBZ  
(B)=  
(C)=

(D)=  
(E)=  
(F)=

No.	Lev.	Parts No.	Description	Q'ty						I	R
				(A)	(B)	(C)	(D)	(E)	(F)		
1	1	719000-01560	BLOCK ASSY, CYLINDER	1							
4	2	171051-01921	PLUG, NPTF1	1							
5	2	119000-02410	BUSH, CAMSHAFT	1							
6	2	23871-030000	PLUG, R03	1							
7	2	27231-600000	PLUG, 60	1							
8	2	27241-140000	PLUG, 14	4							
9	2	27241-400000	PLUG, 40	3							
10	2	135400-01790	PLUG	1							
11	2	119000-01840	PLUG, RUBBER	3							
12	2	129100-01580	PIN, M8X16	2							
13	2	129100-01580	PIN, M8X16	2							
14	2	129100-01580	PIN, M8X16	2							
15	2	22351-080016	PIN, SPRING 8.0X16	2							
16	2	23414-100000	GASKET, 10X1.0	1							
17	2	23414-140000	GASKET, 14X1.0	1							
18	2	135602-34390	RETAINER	1							
19	2	119000-02020	BOLT, METAL CAP	8							
22	2	119000-02800	BEARING, MAIN	4							
25	2	119000-02930	BEARING, THRUST	2							
28	1	119000-01200	BOLT, HEAD	14							
29	1	119000-01340	GASKET, HEAD T=1.3	1							G
30	1	119000-01980	RETAINER, PUMP	1							
31	1	26106-080162	BOLT, M8X 16 PLATED	2							
32	1	719000-02870	BEARING, 0.25 US	4							1
35	1	719000-02940	BEARING, THRUST 0.25	2							2

**Remarks**

- (1) UNDER-SIZED(U.S=0.25)PART.
- (2) OVER-SIZED(O.S=0.25)PART.
- (G) THESE PARTS ARE SOLD BY FIG.18, REF.NO.1,1-1,1-2.

Fig.2. GEAR HOUSING

(A)=3TN100L-TBZ

(B)=

(C)=

(D)=

(E)=

(F)=

Y0003523  
37N100L-TBZ

D19032-01200  
D19032-01210  
D19032-26100

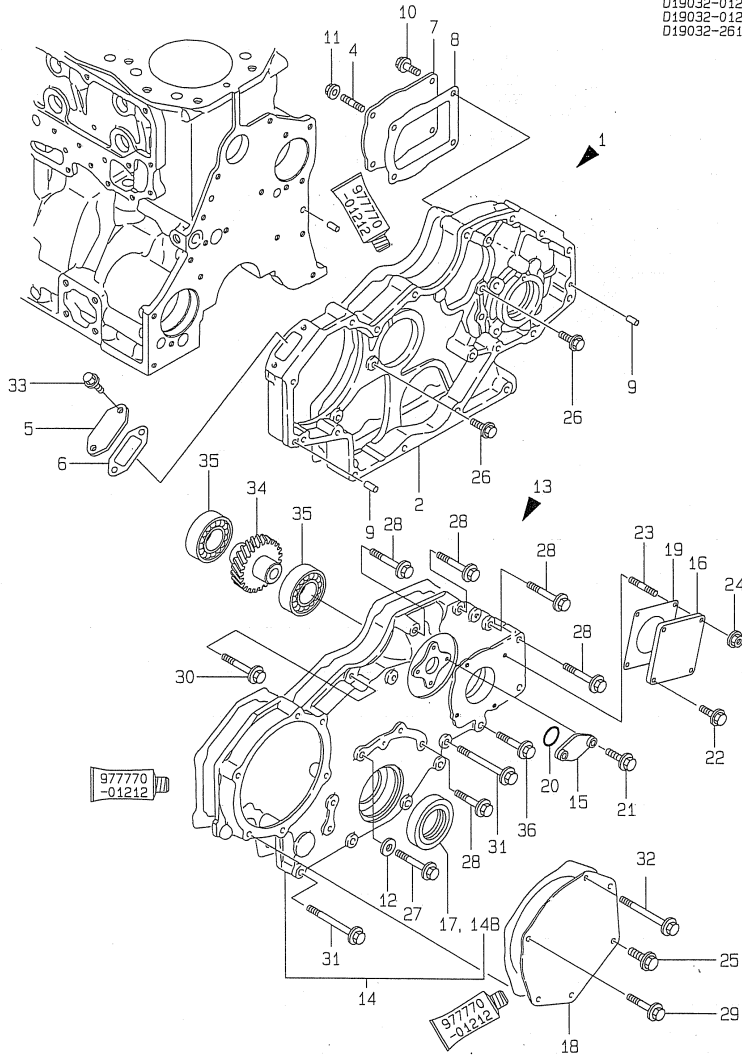

No.	Lev.	Parts No.	Description	Q'ty						I	R
				(A)	(B)	(C)	(D)	(E)	(F)		
1	1	719129-01611	CASE ASSY, GEAR	1							
2	2	719129-01500	COVER ASSY, GEAR CASE	1							
4	3	121850-01920	STUD, 2D8X22	2							
5	2	119000-01740	COVER	1							
6	2	119000-01770	GASKET	1							G
6-1	2	119000-01771	GASKET	1							N G
(A=E03907)											
7	2	124610-01851	COVER	1							
8	2	124610-01861	GASKET	1							G
8-1	2	124610-01862	GASKET	1							N G
(A=E03907)											
9	2	129100-01580	PIN, M8X16	2							
10	2	26106-080202	BOLT, M8X 20 PLATED	2							
11	2	26366-080002	NUT, M8	2							
12	2	43400-500420	SEAL WASHER 8	1							
12-1	2	22190-080003	WASHER, SEAL 8	1							N
(A=E11017)											
13	1	719129-01601	COVER ASSY, GEAR CASE	1							
14	2	119006-01590	COVER ASSY, GEAR CASE	1							W
(A=E03888)											
14B	3	121850-01800	SEAL, OIL	1							W
(A=E03888)											
15	2	121023-01550	COVER	1							
16	2	124240-01871	COVER	1							
17	2	121850-01800	SEAL, OIL	1							Z
(A=E03888)											
18	2	119000-01930	COVER	1							
19	2	124240-01883	GASKET	1							G
20	2	24341-000240	O-RING, 1AS24.0	1							
21	2	26106-060182	BOLT, M6X 18 PLATED	2							
22	2	26106-080202	BOLT, M8X 20 PLATED	2							
23	2	121850-01920	STUD, 2D8X22	2							
24	2	26366-080002	NUT, M8	2							
25	1	26106-080182	BOLT, M8X 18 PLATED	1							
26	1	26106-080202	BOLT, M8X 20 PLATED	5							
27	1	26106-080402	BOLT, M8X 40 PLATED	1							
28	1	26106-080452	BOLT, M8X 45 PLATED	6							
29	1	26106-080452	BOLT, M8X 45 PLATED	3							
30	1	26106-080552	BOLT, M8X 55 PLATED	1							
31	1	26106-080752	BOLT, M8X 75 PLATED	4							
32	1	26106-080902	BOLT, M8X 90 PLATED	2							
33	1	26106-080252	BOLT, M8X 25 PLATED	2							
34	1	119100-26200	GEAR, PUMP	1							
35	1	24101-060064	BEARING, BALL 6006	2							
35-1	1	24105-060064	BEARING, BALL 6006Z	2							N
(A=E08144)											
36	1	26106-080352	BOLT, M8X 35 PLATED	1							

Remarks

(G) THESE PARTS ARE SOLD BY FIG.18,  
REF.NO.1,1-1,1-2.

Fig.3. FLYWHEEL HOUSING & OIL SUMP

Y00D3523  
3TN100L-TBZ

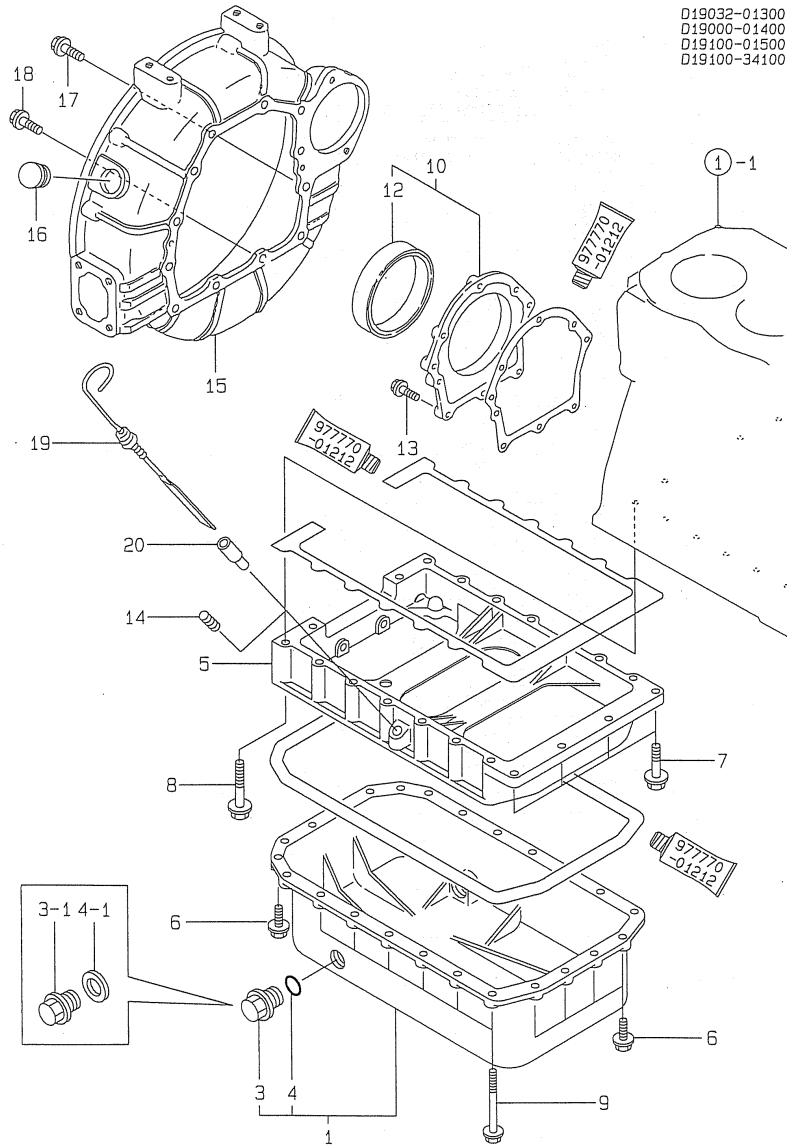

(A)=3TN100L-TBZ

(B)=

(C)=

(D)=

(E)=

(F)=

No.	Lev.	Parts No.	Description	Q'ty						I	R
				(A)	(B)	(C)	(D)	(E)	(F)		
1	1	119000-01780	SUMP ASSY, OIL	1							
3	2	171301-01640	PLUG, 22	2							
3-1	2	171301-01640	PLUG, 22	1							K
		(A=E11530)									
3-2	2	119640-01640	PLUG, DRAIN M22	1							S
		(A=E11530)									
4	2	24341-000240	O-RING, 1AS24.0	2							
4-1	2	24341-000240	O-RING, 1AS24.0	1							K
		(A=E11530)									
4-2	2	22190-220002	WASHER, SEAL 22	1							S
		(A=E11530)									
5	1	119000-01730	SPACER, OIL SUMP	1							
6	1	26106-080252	BOLT, M8X 25 PLATED	8							
7	1	26106-080352	BOLT, M8X 35 PLATED	4							
8	1	26106-080702	BOLT, M8X 70 PLATED	2							
9	1	26106-080802	BOLT, M8X 80 PLATED	14							
10	1	119100-01640	CASE ASSY, OIL SEAL	1							
12	2	124411-01780	SEAL, HTC95X115X12	1							
13	1	26106-080252	BOLT, M8X 25 PLATED	8							
14	1	124976-34850	CAP	1							
15	1	119130-01600	HOUSING, FLYWHEEL	1							
15-1	1	119032-01601	HOUSING, FLYWHEEL	1							N
		(A=E08144)									
16	1	119620-01750	CAP	1							
17	1	26106-100252	BOLT, M10X 25 PLATED	8							
18	1	26106-100302	BOLT, M10X 30 PLATED	4							
19	1	119100-34800	DIPSTICK, OIL	1							
20	1	121520-34810	GUIDE, DIPSTICK	1							

Fig.4. CYLINDER HEAD & BONNET

Y0003523  
3TN100L-TBZ

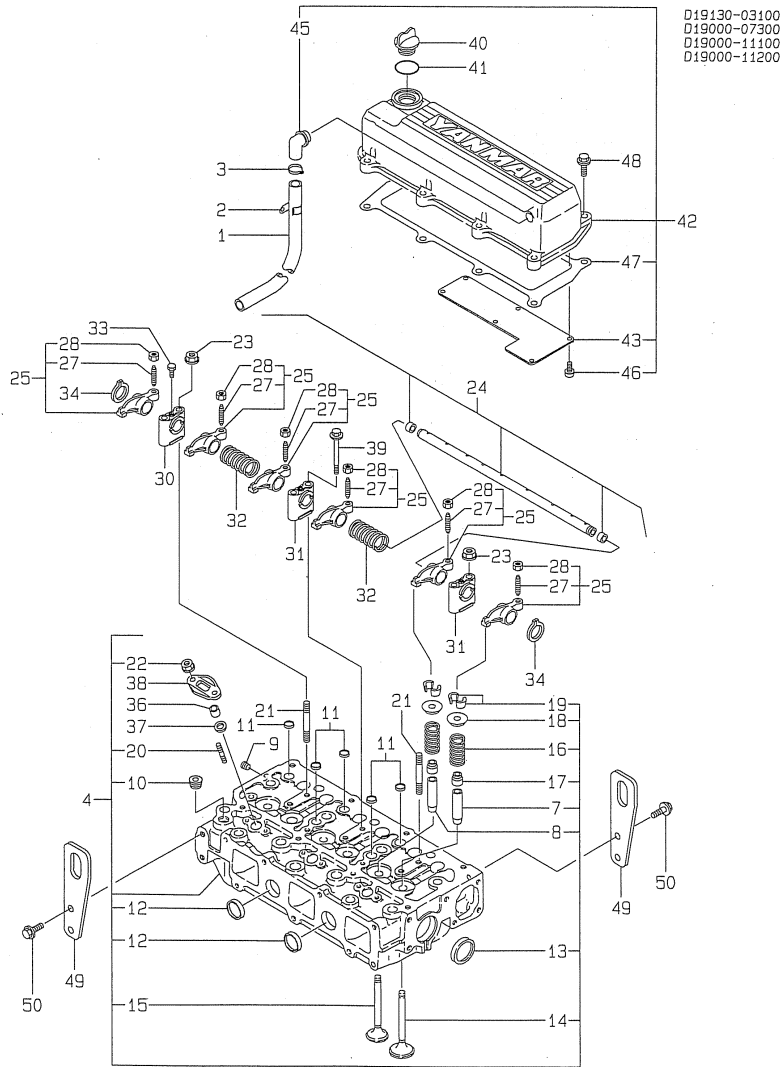

(A)=3TN100L-TBZ

(B)=

(C)=

(D)=

(E)=

(F)=

No.	Lev.	Parts No.	Description	Q'ty						I	R
				(A)	(B)	(C)	(D)	(E)	(F)		
1	1	171350-03090	PIPE , BREATHER 900	1							
2	1	129150-03100	RETAINER, PIPE	1							
3	1	23000-022000	CLAMP, 22	1							Z
(A=E10580)											
4	1	719000-11700	HEAD ASSY, CYLINDER	1							
7	2	121850-11160	GUIDE, VALVE	3							
8	2	119000-11170	GUIDE, VALVE	3							
9	2	123385-82200	PLUG, 1/16	1							
10	2	23871-030000	PLUG, R03	1							
11	2	27241-160000	PLUG, 16	5							
12	2	27241-280000	PLUG, 28	2							
13	2	27241-400000	PLUG, 40	2							
14	2	121850-11100	VALVE, INTAKE	3							
15	2	119000-11110	VALVE, EXHAUST	3							
16	2	121850-11120	SPRING, VALVE	6							
17	2	121850-11150	SEAL, VALVE STEM	6							G
18	2	121850-11180	RETAINER, SPRING	6							
19	2	124250-11190	COTTER	6							
20	2	26216-060252	STUD, M6X 25	6							
21	2	26216-080652	STUD, M8X 65	2							
22	2	26366-060002	NUT, M6	6							
23	2	26366-080002	NUT, M8	2							
24	1	119000-11240	SHAFT ASSY, ROCKER	1							
25	2	719000-11650	ARM ASSY, ROCKER	6							
27	3	119000-11230	SCREW, VALVE ADJUST	6							
28	3	129150-11750	NUT, M8	6							
30	2	119000-11260	SUPPORT, ROCKER ARM	1							
31	2	119000-11270	SUPPORT, ROCKER ARM	2							
32	2	119000-11280	SPRING	2							
33	2	119000-11290	BOLT	1							
34	2	22242-000180	RING, 18	2							
36	1	119625-11870	PROTECTOR, NOZZLE	3							G
37	1	119625-11880	SEAT, NOZZLE	3							G
38	1	119625-11900	RETAINER, NOZZLE	3							
39	1	26106-080652	BOLT, M8X 65 PLATED	4							
40	1	124160-01751	COVER, FILLER	1							
41	1	24311-000320	O-RING, 1AP32.0	1							G
42	1	119000-11311	BONNET ASSY, HEAD	1							
43	2	119000-03200	COVER, BREATHER	1							
45	2	119100-11330	ELBOW	1							
46	2	26022-050122	SCREW, M5X12	7							
47	2	119000-11320	GASKET, BONNET	1							
48	1	26106-080252	BOLT, M8X 25 PLATED	8							
49	1	119000-07200	LIFTER	2							
50	1	26106-100202	BOLT, M10X 20 PLATED	4							

Remarks

(G) THESE PARTS ARE SOLD BY FIG.18,  
REF.NO.1,1-1,1-2.



Fig.5. SUCTION MANIFOLD & AIR CLEANER

(A)=3TN100L-TBZ

(B)=

(C)=

(D)=

(E)=

(F)=

Y0003523  
3TN100L-TBZ

D19006-12100  
D19006-77500  
D19032-93020

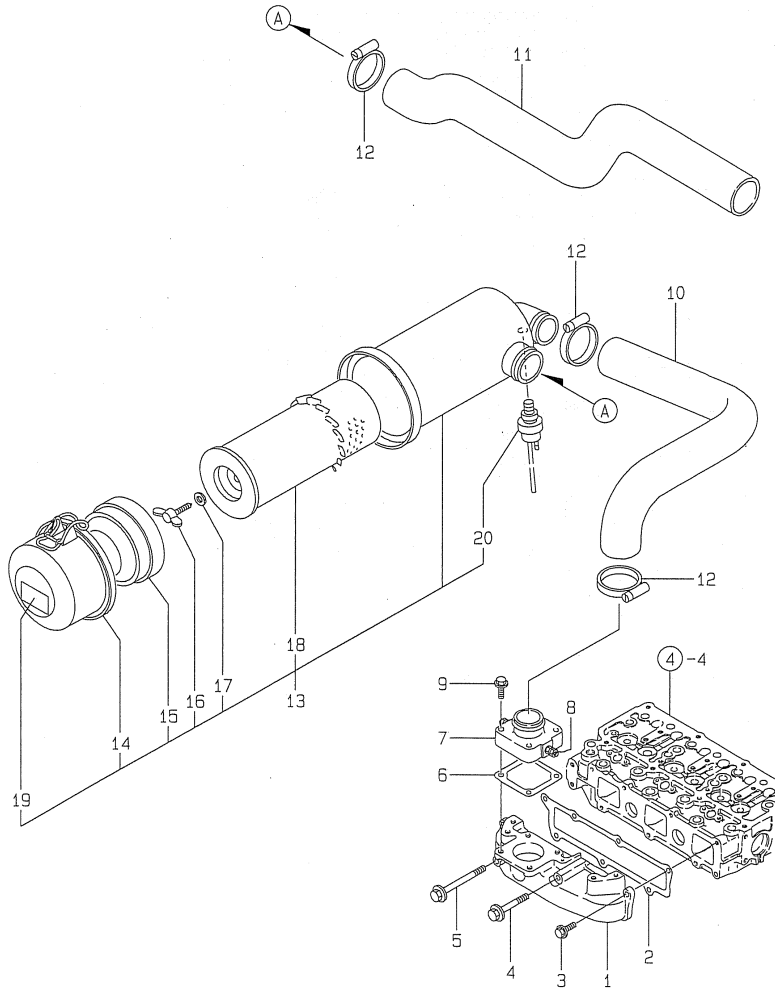

No.	Lev.	Parts No.	Description	Qty						I	R
				(A)	(B)	(C)	(D)	(E)	(F)		
1	1	119000-12100	MANIFOLD, AIR INTAKE	1							
2	1	119000-12110	GASKET, MANIFOLD	1							G
3	1	26106-080202	BOLT, M8X 20 PLATED	5							
4	1	26106-080702	BOLT, M8X 70 PLATED	1							
5	1	26106-081152	BOLT, M8X115 PLATED	1							
6	1	121850-77020	GASKET	1							G
6-1	1	121850-77021	GASKET	1							N G
(A=E03907)											
7	1	121850-77050	HEATER	1							
8	1	129100-77820	WIRE	1							
9	1	26106-080352	BOLT, M8X 35 PLATED	4							
10	1	119032-12250	PIPE, AIR INTAKE	1							
11	1	119032-12260	PIPE, AIR INTAKE	1							
12	1	23000-070000	CLAMP, 70	3							
13	1	119032-12500	CLEANER, AIR	1							
14	2	121850-12530	PAN ASSY, DUST	1							
15	2	121492-12700	RETAINER, ELEMENT	1							
16	2	121120-12561	BOLT	1							
17	2	121120-12571	WASHER, SEAL	1							
18	2	121850-12510	ELEMENT	1							
19	2	121258-12600	LABEL, AIR CLEANER	1							
20	2	121262-12800	INDICATOR	1							

Remarks  
(G) THESE PARTS ARE SOLD BY FIG.18,  
REF.NO.1,1-1,1-2.

Fig.6. EXHAUST MANIFOLD & SILENCER

(A)=3TN100L-TBZ

(B)=

(C)=

(D)=

(E)=

(F)=

Y0003523  
3TN100L-TBZ

D19000-13100TK  
D19032-93020

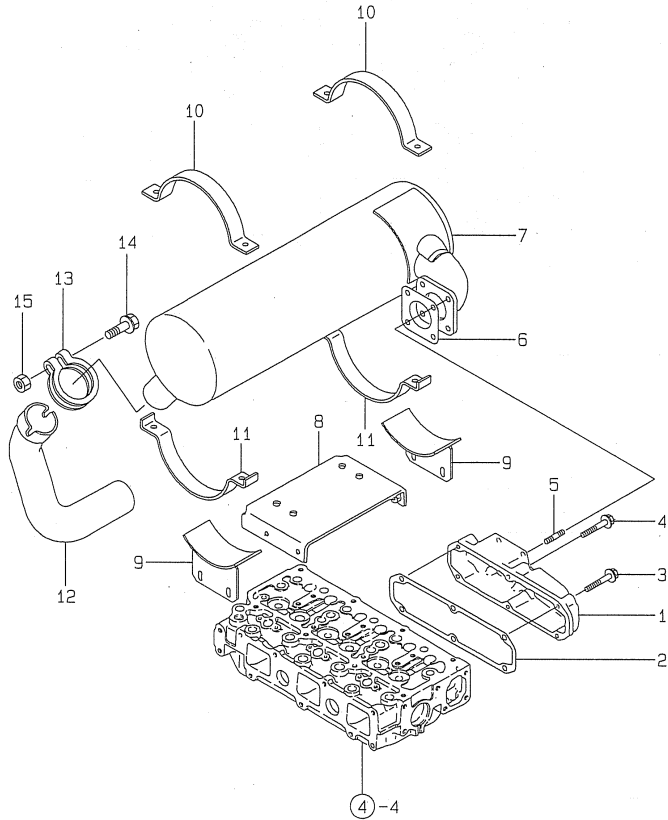

No.	Lev.	Parts No.	Description	Q'ty						I	R
				(A)	(B)	(C)	(D)	(E)	(F)		
1	1	119000-13100	MANIFOLD, EXHAUST	1							
2	1	119000-13200	GASKET	1							G
3	1	26106-080402	BOLT, M8X 40 PLATED	4							
4	1	26106-080502	BOLT, M8X 50 PLATED	2							
5	1	26216-080222	STUD, M8X 22	4							
6	1	129400-13200	GASKET, SILENCER	1							G
6-1	1	129400-13201	GASKET, SILENCER	1							N G
		(A=E03907)									
7	1	119032-13500	SILENCER	1							
8	1	119032-13650	BRACKET, SILENCER	1							
9	1	171091-13660	STAY, SILENCER	2							
10	1	171091-13670	BAND	2							
11	1	171091-13680	BAND	2							
12	1	119032-13570	PIPE	1							
12-1	1	119032-13571	PIPE	1							N
		(A=E04208)									
13	1	121423-13580	CLAMP	1							
14	1	26106-100652	BOLT, M10X 65 PLATED	1							Z
		(A=EXXX)									
15	1	26706-100002	NUT, M10	1							Z
		(A=EXXX)									

Remarks

(G) THESE PARTS ARE SOLD BY FIG.18,  
REF.NO.1,1-1,1-2.

# Fig.7. CAMSHAFT & DRIVE GEAR

Y0003523  
3TN100L-TBZ

019000-14100  
019000-25100

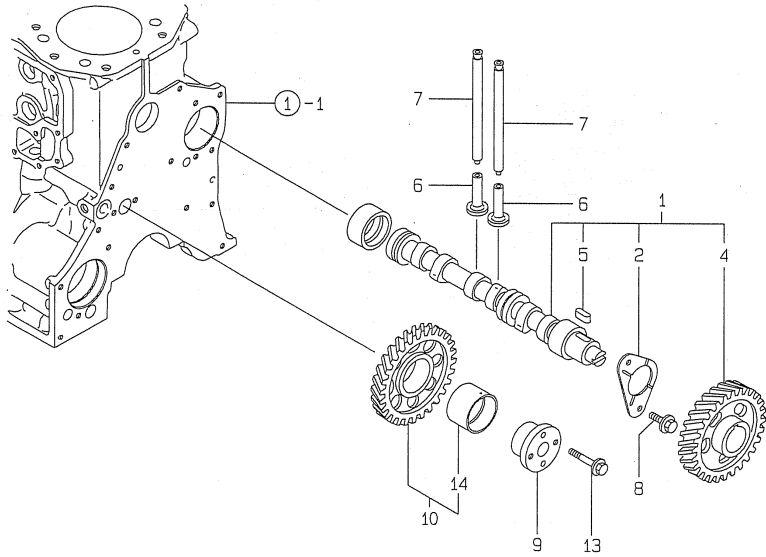

(A)=3TN100L-TBZ

(B)=

(C)=

(D)=

(E)=

(F)=

No.	Lev.	Parts No.	Description	Q'ty						I	R
				(A)	(B)	(C)	(D)	(E)	(F)		
1	1	119000-14000	CAMSHAFT ASSY	1							
2	2	119000-02450	BEARING, THRUST	1							
4	2	119000-14100	GEAR, CAMSHAFT Z=48	1							
5	2	22512-070140	KEY, 7X 14	1							
6	1	119000-14200	TAPPET	6							
7	1	129150-14400	ROD, PUSH L=178	6							
8	1	26106-080162	BOLT, M8X 16 PLATED	2							
9	1	119000-25050	SHAFT, IDLE GEAR	1							
10	1	119000-25100	GEAR ASSY, IDLE Z=51	1							
13	1	26013-080452	BOLT, M8X 45	2							
14	1	119000-25930	BUSH, IDLE GEAR	1							1

Remarks

(1) REPAIR PART.

# Fig.8. CRANKSHAFT & PISTON

Y0003523  
3TN100L-TBZ

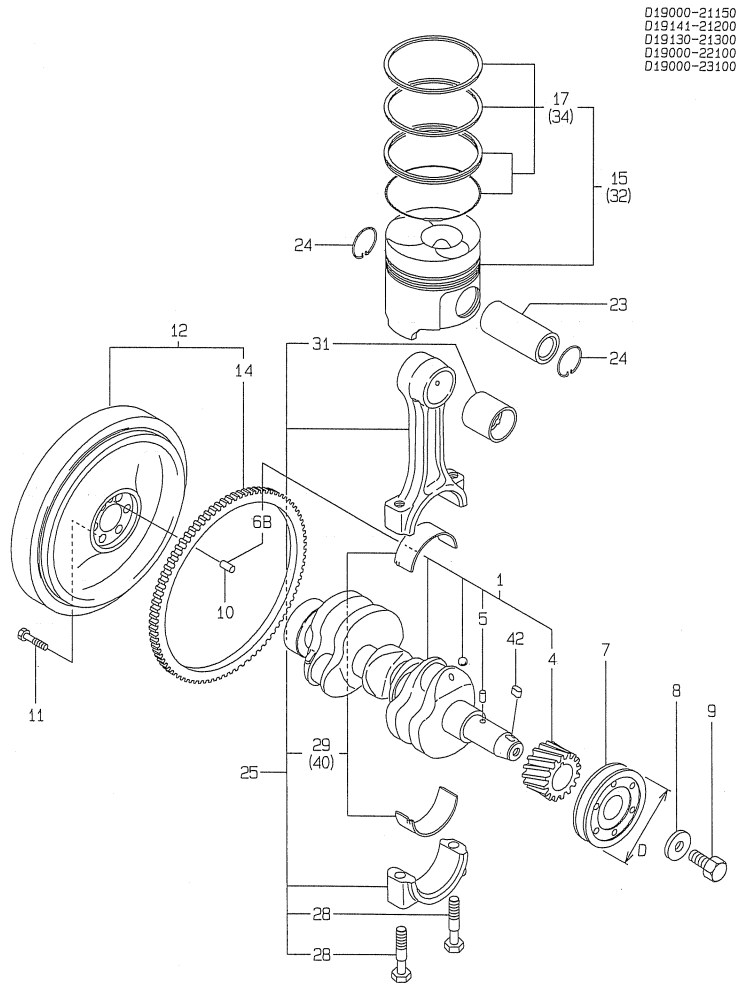

(A)=3TN100L-TBZ

(B)=

(C)=

(D)=

(E)=

(F)=

No.	Lev.	Parts No.	Description	Q'ty						I	R
				(A)	(B)	(C)	(D)	(E)	(F)		
1	1	719000-21700	CRANKSHAFT ASSY	1							
4	2	121850-21200	GEAR, CRANKSHAFT	1							
5	2	121850-21290	PIN	1							
6B	2	121850-21920 (A=E10195)	PIN, M10X22	1							W
7	1	119000-21650	V-PULLEY	1							
7-1	1	119141-21650 (A=E10195)	V-PULLEY	1							S 4
8	1	121850-21660	WASHER	1							
9	1	121850-21680	BOLT	1							
10	1	121850-21920 (A=E10195)	PIN, M10X22	1							Z
11	1	121850-21130	BOLT, FLYWHEEL	6							
12	1	119130-21590	FLYWHEEL ASSY	1							
14	2	124550-21600	GEAR, RING	1							
15	1	119000-22000	PISTON ASSY	3							
17	2	719000-22500	RING SET, PISTON	3							
23	1	119000-22300	PIN, PISTON	3							
24	1	22252-000340	RING, 34	6							
25	1	719000-23100	ROD ASSY, CONNECTING	3							
28	2	121850-23200	BOLT, CONNECTING ROD	6							
29	2	719000-23600	BEARING, CRANK PIN	3							
31	1	119000-23910	BEARING, PISTON PIN	3							
32	1	719000-22900	PISTON ASSY, 0.25 OS	3							2
34	2	719000-22950	RING SET, 0.25 OS	3							2
40	1	719000-23610	BEARING ASSY, 0.25	3							3
42	1	22512-070140	KEY, 7X 14	1							

Remarks

- (1) REPAIR PART.
- (2) OVER-SIZED(O.S=0.25)PART.
- (3) UNDER-SIZED(U.S=0.25)PART.
- (4) D=REF.NO.7 130M/M,7-1 145M/M.

# Fig.9. LUB. OIL SYSTEM

(A)=3TN100L-TBZ

(B)=

(C)=

(D)=

(E)=

(F)=

Y0003523  
3TN100L-TBZ

019000-32100  
019100-35100  
019100-35200  
019000-39200

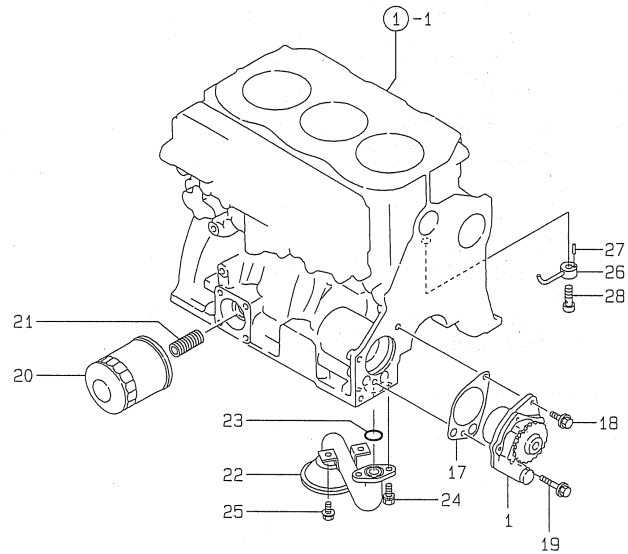

No.	Lev.	Parts No.	Description	Q'ty						I	R
				(A)	(B)	(C)	(D)	(E)	(F)		
1	1	119000-32001	PUMP ASSY, OIL	1							
17	1	119000-32020	GASKET, PUMP	1							G
18	1	26106-080162	BOLT, M8X 16 PLATED	1							
19	1	26106-080502	BOLT, M8X 50 PLATED	1							
20	1	119100-35100	FILTER, OIL	1							
20-1	1	119005-35100	FILTER, D80X100L	1							R
(A=E06274)											
21	1	119000-35140	BOLT, FILTER	1							
22	1	119100-35090	PIPE ASSY, OIL INLET	1							
23	1	24311-000220	O-RING, 1AP22.0	1							
24	1	26013-080162	BOLT, M8X 16	2							
25	1	26106-080162	BOLT, M8X 16 PLATED	2							
26	1	119000-39650	NOZZLE	3							
27	1	22351-030010	PIN, SPRING 3.0X10	3							
28	1	23857-030000	BOLT, JOINT 3	3							

Remarks  
(G) THESE PARTS ARE SOLD BY FIG.18,  
REF.NO.1,1-1,1-2.

Fig.10. OIL COOLER CASE

(A)=3TN100L-TBZ

(B)=

(C)=

(D)=

(E)=

(F)=

Y00D3523  
3TN100L-TBZ

D19000-33100  
D19000-39100  
D19100-39400

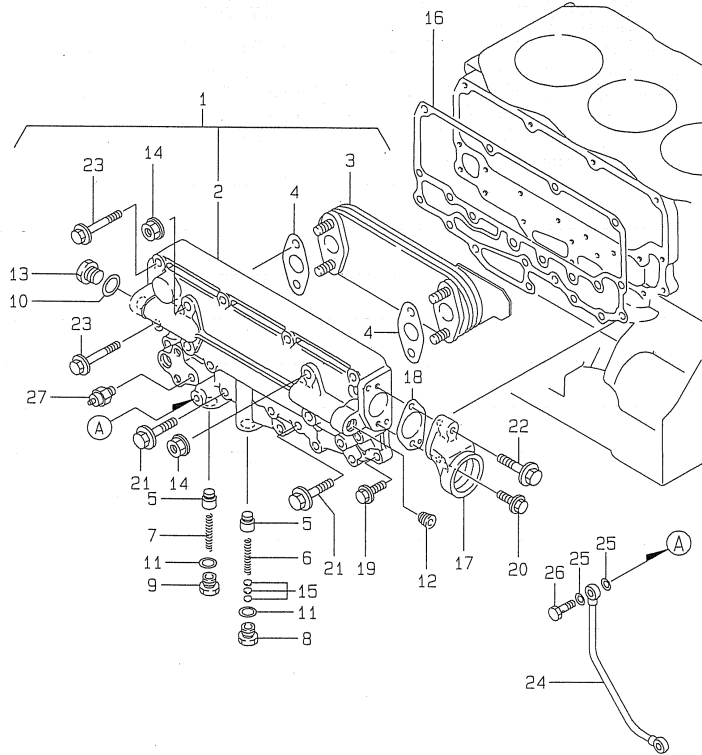

No.	Lev.	Parts No.	Description	Q'ty						I	R
				(A)	(B)	(C)	(D)	(E)	(F)		
1	1	719000-33700	COOLER ASSY, OIL	1							
2	2	119000-33010	CASE, OIL COOLER	1							
3	2	119000-33050	COOLER, OIL	1							
4	2	121952-33070	GASKET, COOLER	2							G
4-1	2	121952-33071	GASKET, COOLER	2							N G
(A=E03907)											
5	2	119000-34030	VALVE, CONTROL	2							
6	2	124411-35520	SPRING	1							
7	2	121952-39830	SPRING	1							
8	2	124223-35510	RETAINER, SPRING	1							
9	2	123672-84530	RETAINER, VALVE	1							
10	2	23414-160000	GASKET, 16X1.0	1							
11	2	23414-180000	GASKET, 18X1.0	2							
12	2	23871-030000	PLUG, R03	1							
13	2	23887-160002	PLUG, 16	1							
14	2	26376-100002	NUT, M10	4							
15	2	121850-35230	SHIM, T=1.0	5							
16	1	119000-33020	GASKET	1							G
16-1	1	119000-33021	GASKET	1							N G
(A=E03907)											
16-2	1	119000-33022	GASKET	1							N G
(A=E11112)											
17	1	119000-33030	BEND	1							
18	1	119000-33040	GASKET	1							G
18-1	1	119000-33041	GASKET	1							N G
(A=E03907)											
19	1	26106-080202	BOLT, M8X 20 PLATED	3							
20	1	26106-080202	BOLT, M8X 20 PLATED	1							
21	1	26106-080352	BOLT, M8X 35 PLATED	8							
22	1	26106-080352	BOLT, M8X 35 PLATED	1							
23	1	26106-080502	BOLT, M8X 50 PLATED	10							
24	1	119000-39350	PIPE, OIL	1							
25	1	23414-080000	GASKET, 8X1.0	2							
26	1	23857-030000	BOLT, JOINT 3	1							
27	1	121250-39450	SWITCH, 1.0KG	1							

Remarks

(G) THESE PARTS ARE SOLD BY FIG.18,  
REF.NO.1,1-1,1-2.

Fig.11. COOLING WATER SYSTEM

Y00D3522  
3TN100L-TBZ

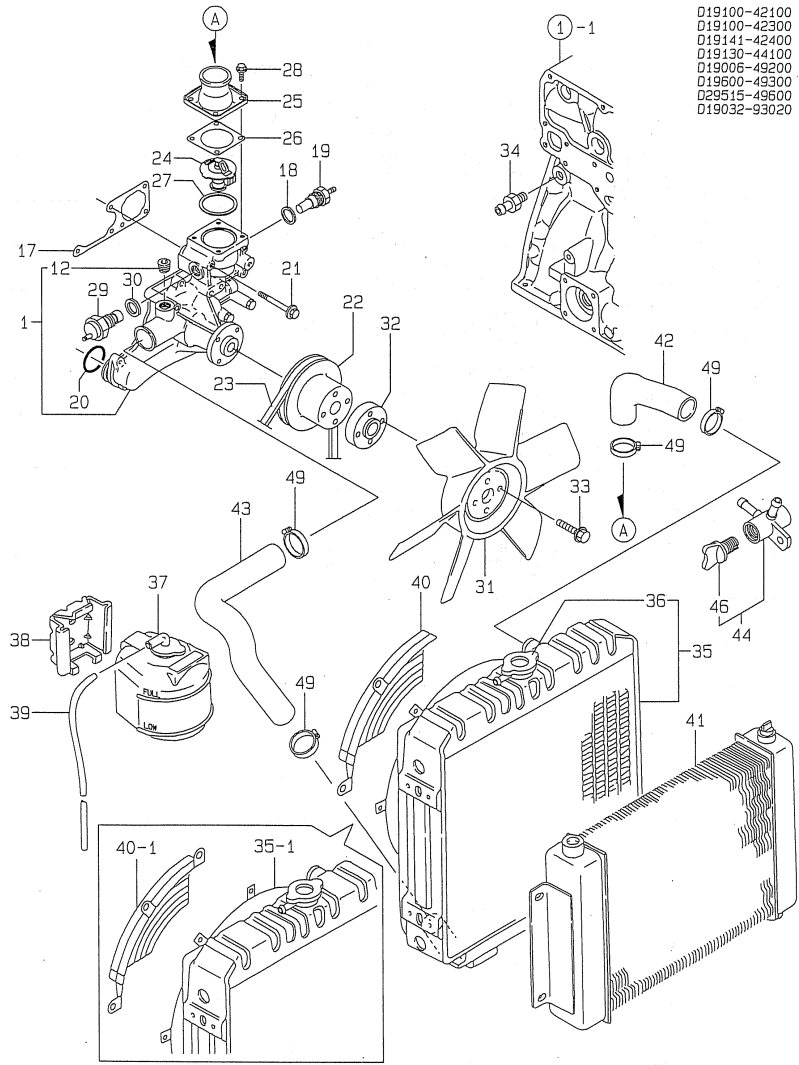

(A)=3TN100L-TBZ

(B)=

(C)=

(D)=

(E)=

(F)=

No.	Lev.	Parts No.	Description	Q'ty						I	R
				(A)	(B)	(C)	(D)	(E)	(F)		
1	1	119006-42000	PUMP ASSY, WATER	1							
1-1	1	119006-42001	PUMP ASSY, WATER	1							N
(A=E04208)											
12	2	23871-030000	PLUG, R03	1							
17	1	119000-42020	GASKET, WATER PUMP	1							G
17-1	1	119000-42021	GASKET, WATER PUMP	1							N G
(A=E03907)											
18	1	129150-49360	GASKET	1							
19	1	171056-49351	SENSOR	1							
20	1	24311-000360	O-RING, 1AP36.0	1							G
21	1	26106-080652	BOLT, M8X 65 PLATED	5							
22	1	119000-42250	V-PULLEY	1							
23	1	171087-42280	V-BELT, A44	1							
23-1	1	129052-96150	V-BELT, A45	1							S
(A=E10195)											
24	1	119000-48170	THERMOSTAT, 71	1							
25	1	121850-49530	COVER, THERMOSTAT	1							
26	1	121850-49540	GASKET, THERMOSTAT	1							G
27	1	121850-49550	GASKET, THERMOSTAT	1							G
28	1	26014-060142	BOLT, M6X 14	4							
29	1	121250-44901	SWITCH, 110	1							
30	1	124465-44950	GASKET, 16	1							
31	1	121950-44741	FAN, COOLING	1							
32	1	119130-44760	SPACER, FAN	1							
33	1	26014-080452	BOLT, M8X 45	4							
34	1	121550-49111	JOINT, PT1/4	1							
35	1	119032-44500	RADIATOR	1							
35-1	1	119032-44501	RADIATOR	1							S
(A=E11443)											
36	2	124450-44590	CAP, RADIATOR	1							
37	1	120445-44530	TANK, SUB	1							
38	1	120445-44540	SUPPORT	1							
39	1	127420-44560	PIPE, OVERFLOW L=740	1							
40	1	119032-44590	NET, WIRE	1							
40-1	1	119032-44591	NET, WIRE	1							S
(A=E11443)											
41	1	171091-44900	COOLER ASSY, OIL	1							
42	1	121970-49010	PIPE, WATER	1							
43	1	119130-49020	PIPE, WATER	1							
44	1	129150-49100	COCK ASSY, 3-WAY	1							
46	2	129150-49080	COCK, DRAIN	1							
49	1	23010-050000	CLAMP, 50	4							

Remarks

(G) THESE PARTS ARE SOLD BY FIG.18,  
REF.NO.1,1-1,1-2.

# Fig.12. FUEL INJECTION PUMP

Y0003523  
3TN100L-TBZ

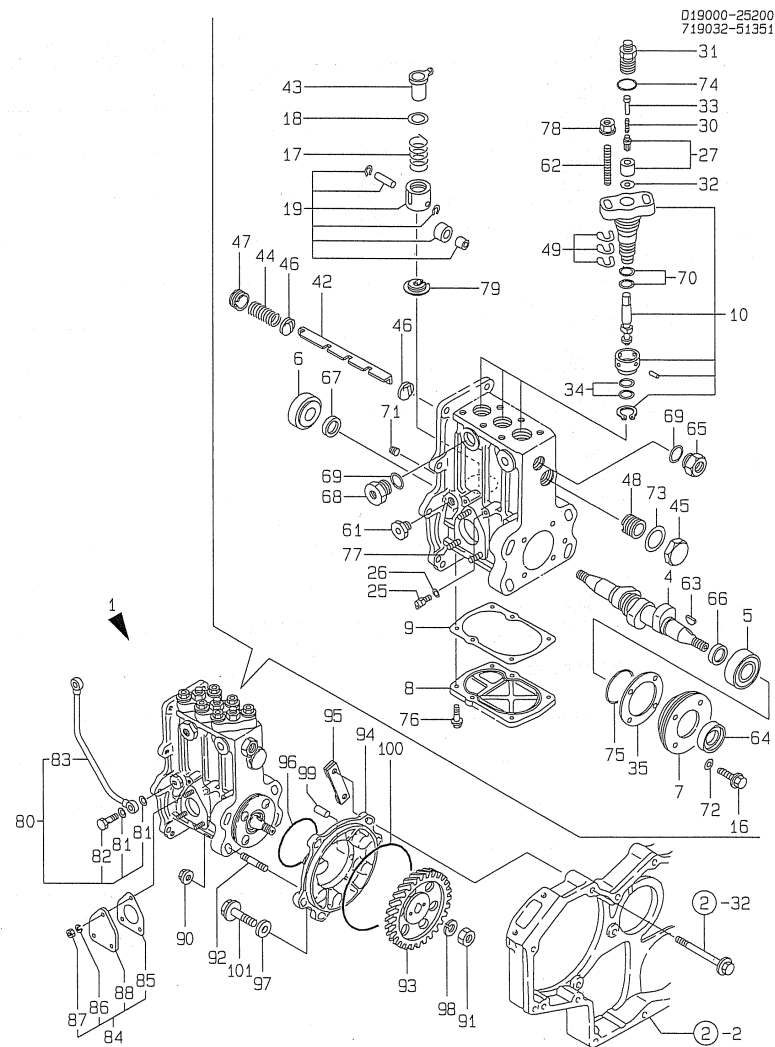

Remarks  
(1) GOVERNOR ASSY(FIG.15) IS  
INCORPORATED IN THIS FUEL  
INJECTION PUMP ASSY(REF.NO.1).

(A)=3TN100L-TBZ  
(B)=  
(C)=

(D)=  
(E)=  
(F)=

No.	Lev.	Parts No.	Description	Q'ty						I	R
				(A)	(B)	(C)	(D)	(E)	(F)		
1	1	719032-51351	PUMP ASSY, INJECTION	1							1
4	3	119000-51030	CAMSHAFT	1							
5	3	119000-51050	BEARING, HR32005XJ	1							
6	3	122710-51050	BEARING, HR30203J	1							
7	3	119000-51060	SUPPORT, BEARING A	1							
8	3	119000-51081	COVER	1							
9	3	119000-51091	GASKET	1							
10	3	119000-51101	PLUNGER ASSY	3							
16	3	26106-060202	BOLT, M6X 20 PLATED	4							
17	3	119000-51161	SPRING, PLUNGER	3							
18	3	119000-51170	SEAT, SPRING A	3							
19	3	119000-51201	TAPPET ASSY	3							
25	3	129155-51270	STOPPER, TAPPET	3							
26	3	129155-51280	O-RING, S6	3							
27	3	128400-51300	VALVE ASSY, DELIVERY	3							
30	3	119000-51330	SPRING, DELIVERY	3							
31	3	119000-51340	HOLDER, DELIVERY	3							
32	3	122710-51350	GASKET	3							
33	3	119000-51360	STOPPER, VALVE	3							
34	3	119000-51410	O-RING, S18	6							
35	3	119000-51450	SHIM SET, CAMSHAFT	1							
42	3	119000-51500	RACK, CONTROL	1							
43	3	119000-51510	SLEEVE, CONTROL	3							
44	3	119000-51530	SPRING, RACK	1							
45	3	119000-51550	COVER	1							
46	3	119000-51570	GUIDE, RACK	2							
47	3	119000-51580	SCREW	1							
48	3	119000-51590	SCREW	1							
49	3	119000-51650	SHIM SET, ADJUSTING	6							
61	3	121850-51700	BUSH	1							
62	3	119000-51800	BOLT	6							
63	3	144626-51090	KEY, 5X19	1							
64	3	119000-51900	SEAL, AC1290E0	1							
65	3	121952-51900	PLUG	1							
66	3	119000-51911	SPACER, CAMSHAFT	1							
67	3	122710-51920	SPACER	1							
68	3	144626-51940	PLUG	1							
69	3	144626-51950	O-RING, 1016	2							
70	3	24341-000260	O-RING, 1AS26.0	3							
71	3	137600-53900	SCREW, M6X6	1							
72	3	22190-060000	WASHER, SEAL 6	4							
73	3	23414-220029	GASKET, 22X1.0	1							
74	3	24312-000150	O-RING, 2P15.0	3							
75	3	24341-000500	O-RING, 1AS50.0	1							
76	3	26106-060182	BOLT, M6X 18 PLATED	6							
77	3	26216-060162	STUD, M6X 16	3							Z
(A=E07328)											
78	3	26366-080002	NUT, M8	6							
79	3	119000-51181	SEAT, SPRING B	3							
80	2	119000-51990	PIPE ASSY, OIL	1							
81	3	23414-080000	GASKET, 8X1.0	2							



Fig.12. FUEL INJECTION PUMP

Y00D3523  
3TN100L-TBZ

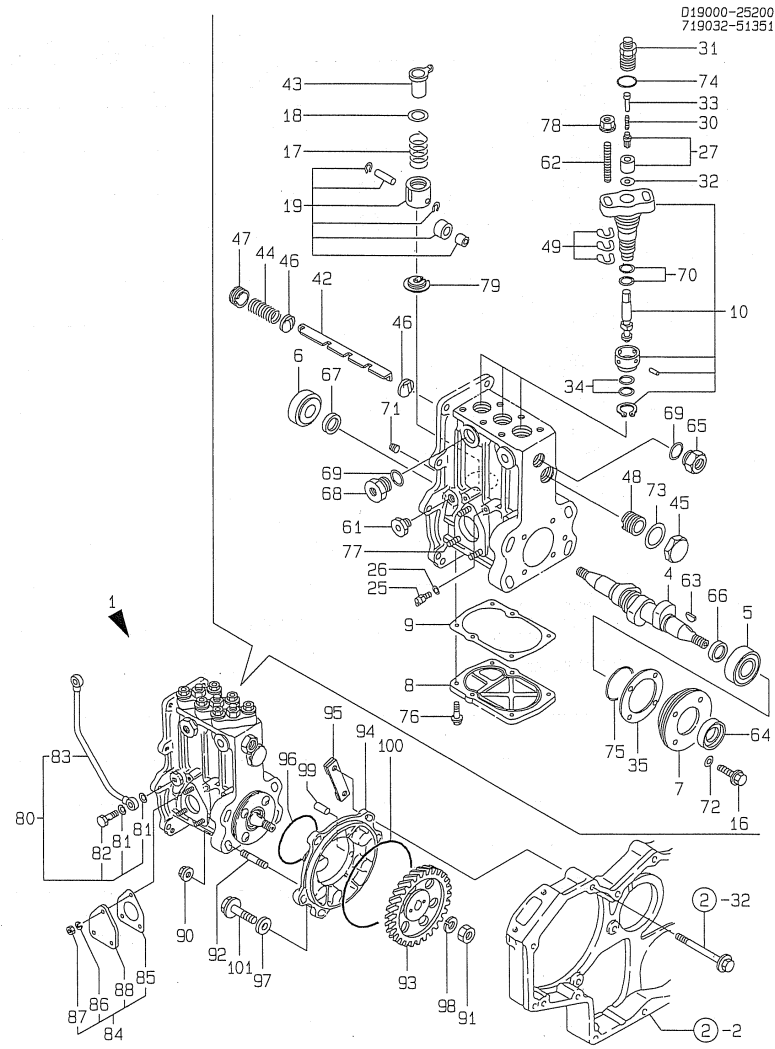

D19000-25200  
719032-51351

(A)=3TN100L-TBZ

(B)=

(C)=

(D)=

(E)=

(F)=

No.	Lev.	Parts No.	Description	Q'ty						I	R
				(A)	(B)	(C)	(D)	(E)	(F)		
82	3	23857-030000	BOLT, JOINT 3	1							
83	3	119000-39350	PIPE, OIL	1							
84	2	119001-52000	COVER ASSY	1							Z
(A=E07328)											
85	3	124410-51860	GASKET	1							
85-1	3	124410-51861	GASKET	1							N
(A=E04208)											
85-2	3	124410-51861	GASKET	1							Z
(A=E07328)											
86	3	22217-060000	WASHER, SPRING 6	3							Z
(A=E07328)											
87	3	26716-060002	NUT, M6	3							Z
(A=E07328)											
88	3	152623-51860	COVER	1							Z
(A=E07328)											
90	1	26366-100002	NUT, M10	4							
91	1	26776-180002	NUT, LOCK M18	1							
92	1	121850-01900	STUD, SB10X32	4							
93	1	119000-25900	GEAR, PUMP	1							
94	1	119000-25910	BRACKET, PUMP	1							
95	1	119000-25920	RETAINER	1							
96	1	124410-51960	O-RING	1							
97	1	106100-55800	WASHER	3							
98	1	22217-180000	WASHER, SPRING 18	1							
99	1	22351-050012	PIN, SPRING 5.0X12	1							
100	1	24341-001350	O-RING, 1AS135.0	1							
101	1	26106-080252	BOLT, M8X 25 PLATED	3							

Remarks

(1) GOVERNOR ASSY(FIG.15) IS INCORPORATED IN THIS FUEL INJECTION PUMP ASSY(REF.NO.1).

Fig.13. FUEL INJECTION PIPE

Y00D3523  
3TN100L-TBZ

D19000-53100  
D19000-59100

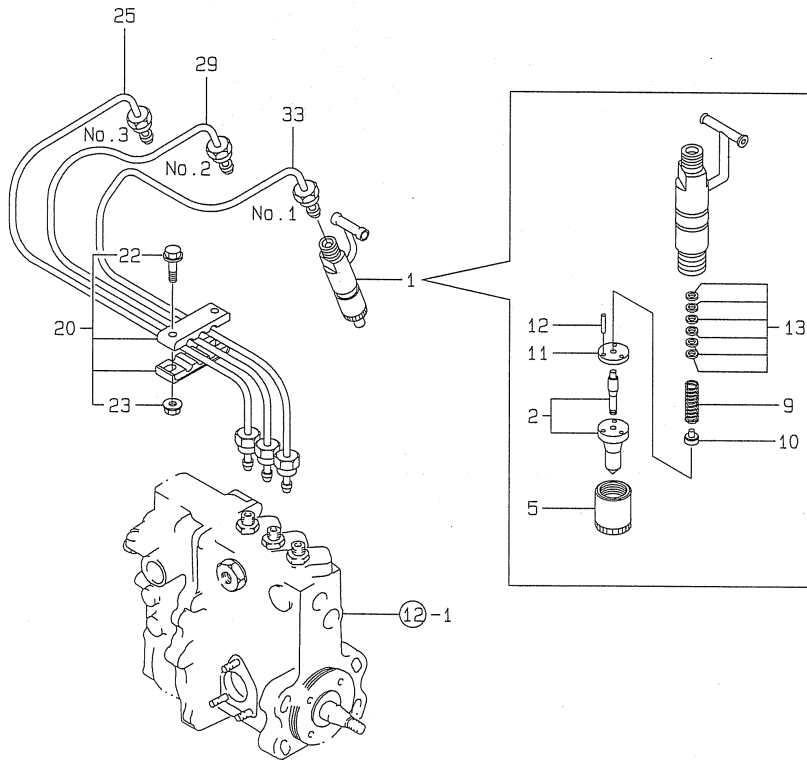

(A)=3TN100L-TBZ

(B)=

(C)=

(D)=

(E)=

(F)=

No.	Lev.	Parts No.	Description	Q'ty						I	R
				(A)	(B)	(C)	(D)	(E)	(F)		
1	1	719000-53100	VALVE ASSY,INJECTION	3							
2	2	119000-53000	VALVE ASSY,INJECTION	3							
5	2	114250-53080	NUT, NOZZLE D16.95	3							
9	2	114250-53120	SPRING, NOZZLE	3							
10	2	114250-53130	SEAT, SPRING	3							
11	2	114250-53140	PLATE	3							
12	2	114250-53210	PIN	3							
12-1	2	114250-53210	PIN	6							K
(A=EXXX)											
13	2	114250-53400	SHIM SET	3							
20	1	123372-59080	RETAINER	1							
22	2	26106-060202	BOLT, M6X 20 PLATED	2							
23	2	26366-060002	NUT, M6	2							
25	1	119100-59820	PIPE ASSY, INJECTION	1							
29	1	119100-59830	PIPE ASSY, INJECTION	1							
33	1	119100-59840	PIPE ASSY, INJECTION	1							

Fig.14. FUEL OIL PIPE

Y00D3523  
3TN100L-TBZ

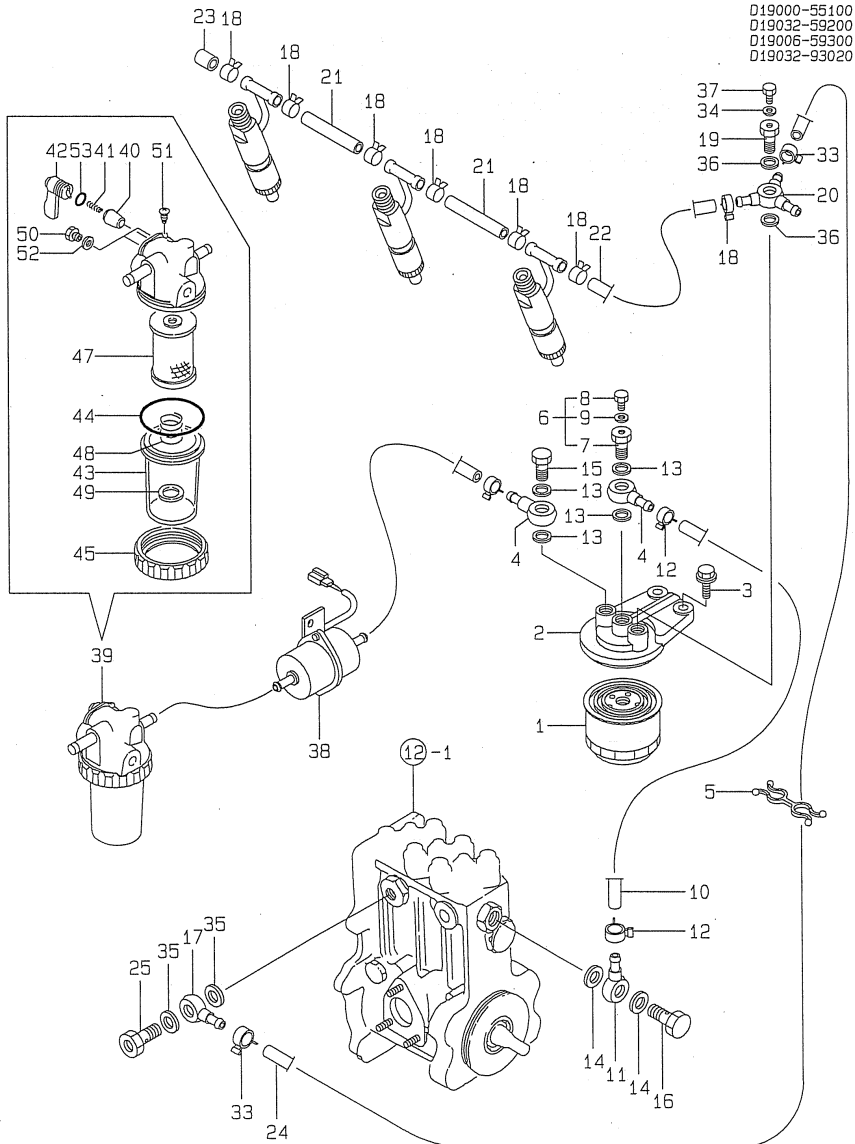

(A)=3TN100L-TBZ

(B)=

(C)=

(D)=

(E)=

(F)=

No.	Lev.	Parts No.	Description	Qty						I	R
				(A)	(B)	(C)	(D)	(E)	(F)		
1	1	119000-55600	FILTER, FUEL	1							
2	1	129470-55610	BODY, STRAINER	1							
3	1	26106-100252	BOLT, M10X 25 PLATED	2							
4	1	101304-59020	JOINT, PIPE 12	2							
5	1	121750-59890	BAND, 140	1							
6	1	103854-59191	BOLT ASSY, JOINT M12	1							
7	2	103854-59201	BOLT, PIPE JOINT M12	1							
8	2	124060-59380	PLUG, 6	1							
9	2	43400-500390	SEAL WASHER 6S	1							
9-1	2	22190-060002	WASHER, SEAL 6	1							N
		(A=E11017)									
10	1	129129-59510	PIPE ASSY, RETURN	1							
11	1	121855-59880	JOINT, PIPE	1							
12	1	23000-013000	CLAMP, 13	2							
13	1	23414-120000	GASKET, 12X1.0	2							
13-1	1	43400-500450	SEAL WASHER 12S	2							N
		(A=E04488)									
13-2	1	22190-120002	WASHER, SEAL 12	2							N
		(A=E11017)									
14	1	23414-140000	GASKET, 14X1.0	2							
14-1	1	43400-500470	SEAL WASHER 14S	2							N
		(A=E04488)									
14-2	1	22190-140002	WASHER, SEAL 14	2							N
		(A=E11017)									
15	1	23857-060000	BOLT, JOINT 6	1							
16	1	23857-080000	BOLT, JOINT 8	1							
17	1	101304-59020	JOINT, PIPE 12	1							
18	1	124066-59100	CLIP, HOSE 8	7							
19	1	129495-59300	BOLT, PIPE JOINT	1							
20	1	129470-59530	JOINT, PIPE	1							
21	1	119000-59550	PIPE, FUEL RETURN	2							
22	1	119000-59560	PIPE, FUEL RETURN	1							
23	1	129150-59580	CAP	1							
24	1	129255-59580	PIPE, FUEL	1							
25	1	129100-59951	VALVE ASSY, CHECK	1							
33	1	23000-013000	CLAMP, 13	2							
34	1	23414-080000	GASKET, 8X1.0	1							
35	1	23414-120000	GASKET, 12X1.0	2							
35-1	1	43400-500450	SEAL WASHER 12S	2							N
		(A=E04488)									
35-2	1	22190-120002	WASHER, SEAL 12	2							N
		(A=E11017)									
36	1	23414-140000	GASKET, 14X1.0	2							
36-1	1	43400-500470	SEAL WASHER 14S	2							N
		(A=E04488)									
36-2	1	22190-140002	WASHER, SEAL 14	2							N
		(A=E11017)									
37	1	26106-080102	BOLT, M8X 10 PLATED	1							
38	1	129322-77401	PUMP ASSY, FUEL FEED	1							
39	1	121850-55800	SEPARATOR ASSY, WATER	1							
40	2	104200-55321	VALVE, TAPER	1							

Fig.14. FUEL OIL PIPE

Y00D3523  
3TN100L-TBZ

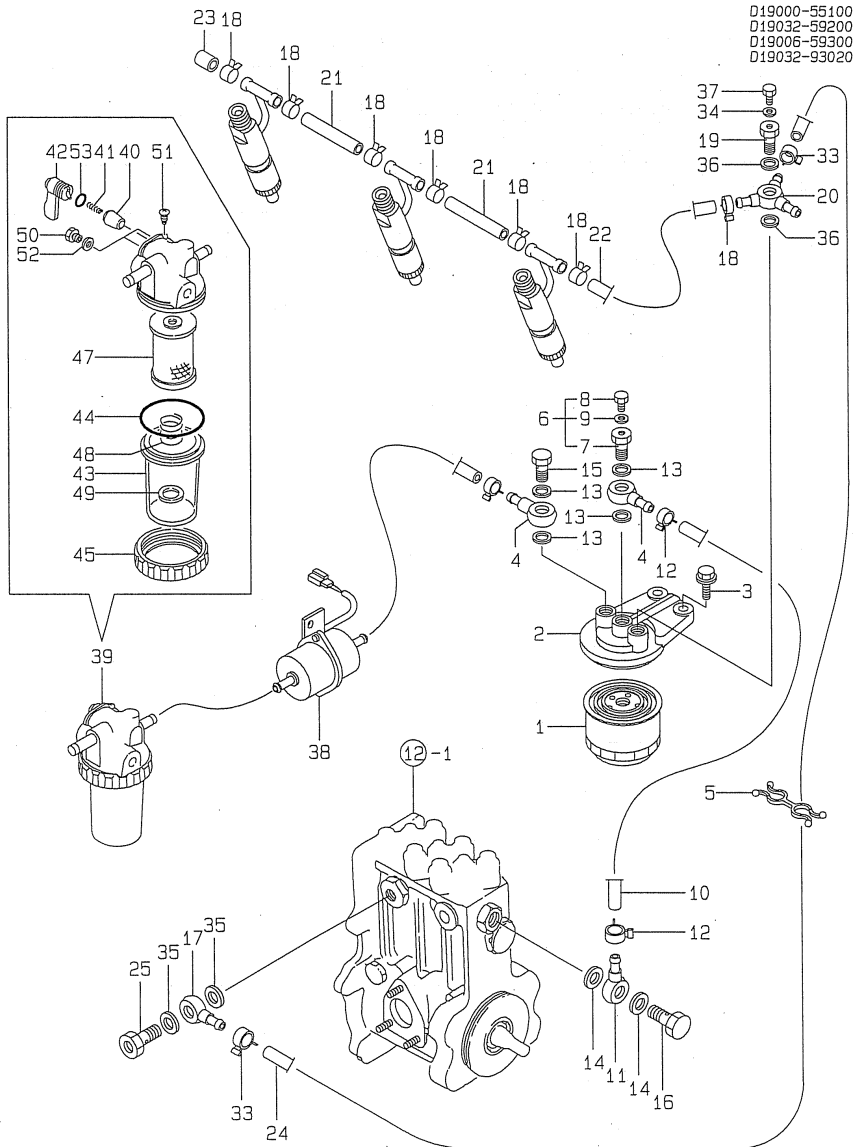

D19000-55100  
D19032-59200  
D19006-59300  
D19032-93020

(A)=3TN100L-TBZ

(B)=

(C)=

(D)=

(E)=

(F)=

No.	Lev.	Parts No.	Description	Q'ty						I	R
				(A)	(B)	(C)	(D)	(E)	(F)		
41	2	104200-55330	SPRING, VALVE	1							
42	2	104200-55341	HANDLE	1							
43	2	121254-55510	COVER	1							
44	2	102103-55520	O-RING	1							
45	2	110250-55610	RING, RETAINING	1							
47	2	121850-55710	SCREEN	1							
48	2	121257-55720	SPRING	1							
49	2	121257-55731	FLOAT	1							
50	2	101720-55750	PLUG, 6	2							
51	2	104200-55750	SCREW, M4	1							
52	2	23418-060000	GASKET, 6X1.0	2							
53	2	24311-240100	O-RING, 1AP10A	1							

# Fig.15. COVERNOR

Y0003523  
3TN100L-TBZ

719032-51351

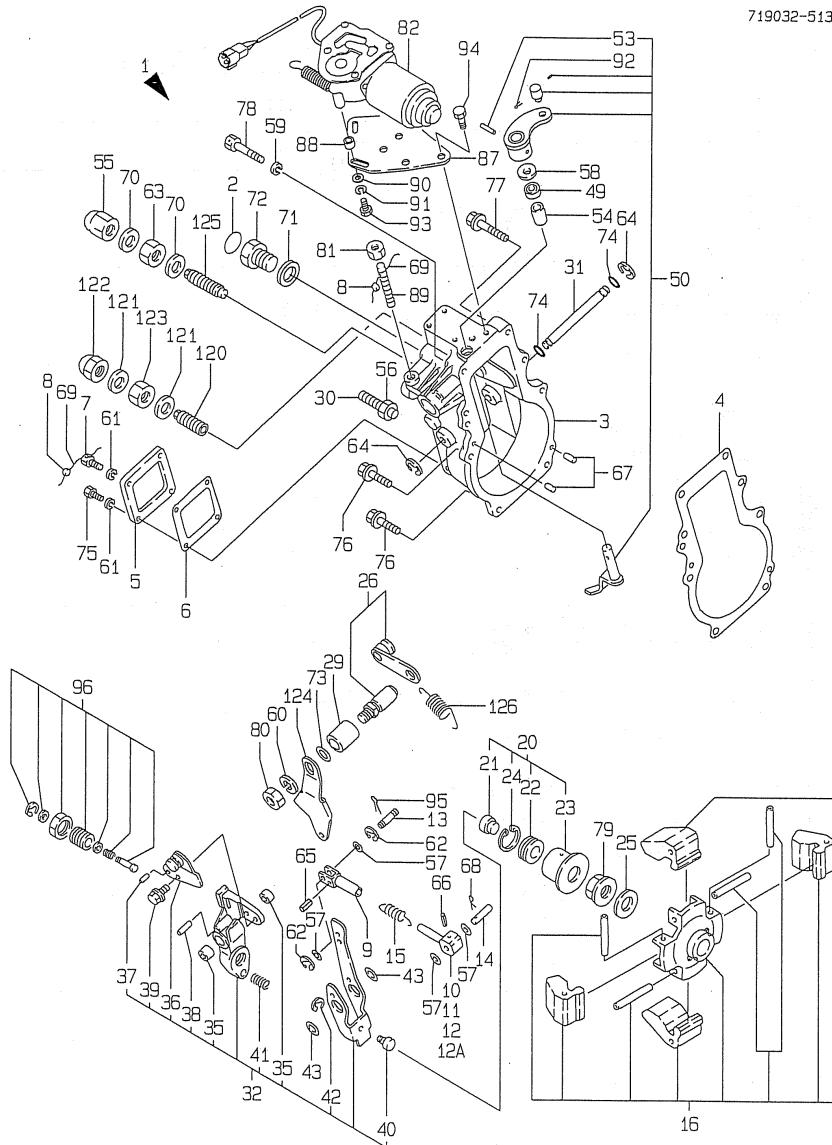

(A)=3TN100L-TBZ

(B)=

(C)=

(D)=

(E)=

(F)=

No.	Lev.	Parts No.	Description	Qty						I	R
				(A)	(B)	(C)	(D)	(E)	(F)		
1	2	119023-61000	GOVERNOR ASSY	1							
2	3	124610-51970	LABEL	1							
3	3	119000-61011	CASE, GOVERNOR	1							
4	3	119000-61050	GASKET	1							
4-1	3	119000-61051	GASKET	1							N
(A=E04208)											
5	3	120323-61060	COVER, GOVERNOR CASE	1							
6	3	120323-61070	GASKET	1							
7	3	129155-61090	BOLT	1							
8	3	135210-61090	LEAD	2							
9	3	119000-61120	LINK	1							
10	3	119000-61140	LINK, MARK-1 L=40	1							
11	3	119000-61150	LINK, MARK-2 L=42	1							
12	3	119000-61160	LINK, MARK-3 L=44	1							
12A	3	119000-61080	LINK	1							W
(A=E11112)											
13	3	119000-61170	PIN, LINK	1							
14	3	119000-61180	PIN, LINK	1							
15	3	119000-61190	SPRING	1							
16	3	119000-61200	WEIGHT ASSY,GOVERNOR	1							
20	3	119000-61300	SLEEVE ASSY, L=30	1							
21	4	119000-61310	SHIFTER	1							
22	4	119000-61320	BEARING, THRUST	1							
23	4	119000-61340	SLEEVE	1							
24	4	22262-000260	RING, R-26	1							
25	3	119000-61380	SPACER	1							
26	3	119000-61400	SHAFT ASSY	1							
29	3	119000-61430	BUSH	1							
29-1	3	119100-61430	BUSH	1							R
(A=E07901)											
30	3	129470-61450	BOLT, LIMITER	1							
30-1	3	129155-61460	BOLT, IDLE	1							R
(A=*1991.)											
31	3	119000-61490	SHAFT	1							
32	3	119000-61500	LEVER ASSY, GOVERNOR	1							
35	4	119000-61530	BUSH	2							
36	4	119000-61540	HOOK	1							
37	4	119000-61560	PIN	1							
37-1	4	119000-61561	PIN	1							N
(A=E09769)											
38	4	22351-020016	PIN, SPRING 2.0X16	1							
38-1	4	22351-020012	PIN, SPRING 2.0X12	1							N
(A=E04723)											
39	4	26106-060122	BOLT, M6X 12 PLATED	1							
40	4	124616-61540	SHIFTER	1							
41	4	121850-61600	SPRING, FUEL CONTROL	1							
42	4	22272-000040	RING, E- 4	1							
43	3	119000-61630	SHIM SET	1							
49	3	148616-61650	SEAL, VC081404	1							
50	3	119000-61801	LEVER ASSY, STOP	1							
53	4	22351-030016	PIN, SPRING 3.0X16	1							

Fig.15. COVERNOR

Y0003523  
3TN100L-TBZ

719032-51351

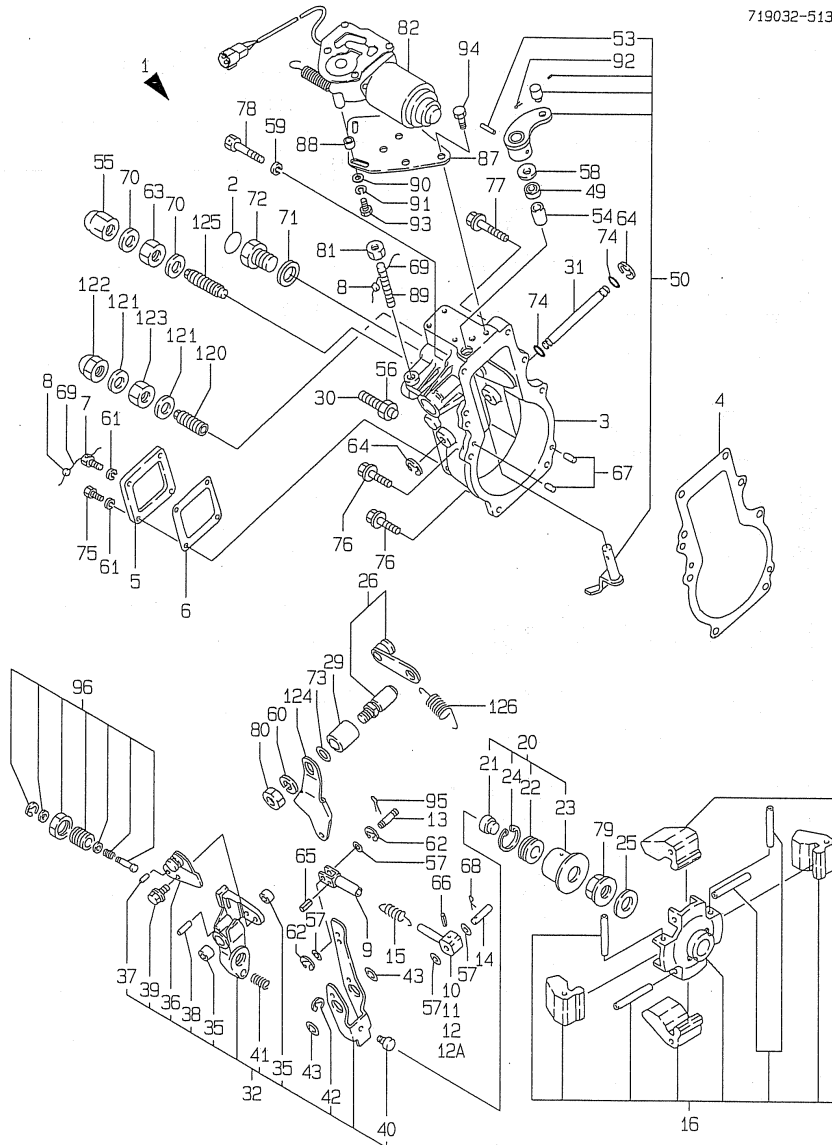

(A)=3TN100L-TBZ

(B)=

(C)=

(D)=

(E)=

(F)=

No.	Lev.	Parts No.	Description	Q'ty						I	R
				(A)	(B)	(C)	(D)	(E)	(F)		
54	3	119000-61841	BUSH	1							
55	3	129100-61930	NUT, CAP	1							
56	3	119000-61470	NUT, M6	1							
57	3	22117-050000	WASHER, 5	4							
58	3	22137-080000	WASHER, 8	2							
59	3	22217-060000	WASHER, SPRING 6	1							
60	3	22217-100000	WASHER, SPRING 10	1							
61	3	22217-050000	WASHER, SPRING 5	4							
62	3	22272-000040	RING, E- 4	2							
63	3	26777-120002	NUT, LOCK M12	1							
64	3	22272-000080	RING, E- 8	2							
65	3	22351-030016	PIN, SPRING 3.0X16	1							
66	3	22351-030025	PIN, SPRING 3.0X25	1							
67	3	22351-050020	PIN, SPRING 5.0X20	2							
68	3	22360-050000	SNAP PIN 5	1							
68-1	3	22372-050000	PIN, SNAP 5	1							R
		(A=E06037)									
69	3	22451-100000	WIRE, 1.0	2							
69-1	3	22453-060000	WIRE, 0.6	2							R
		(A=*1992.)									
70	3	43400-500450	SEAL WASHER 12S	2							
70-1	3	22190-120002	WASHER, SEAL 12	2							N
		(A=E11112)									
71	3	43400-500500	SEAL WASHER 16	1							
71-1	3	22190-160002	WASHER, SEAL 16	1							N
		(A=E11112)									
72	3	23887-160002	PLUG, 16	1							
73	3	24311-000110	O-RING, 1AP11.0	1							
74	3	24341-000080	O-RING, 1AS8.0	2							
75	3	26116-050102	BOLT, M5X 10 PLATED	3							
76	3	26106-060222	BOLT, M6X 22 PLATED	6							
77	3	26106-060352	BOLT, M6X 35 PLATED	1							
78	3	26116-060356	BOLT, M6X 35 PLATED	1							
79	3	26376-120002	NUT, M12	1							
80	3	26736-100002	NUT, M10	1							
80-1	3	26606-100002	NUT, M10	1							R
		(A=*1991.)									
81	3	26757-080002	NUT, LOCK M8	1							
81-1	3	26756-080002	NUT, LOCK M8	1							R
		(A=E07901)									
82	3	119032-61850	MOTOR, STOP	1							
87	3	119000-61870	BRACKET, STOP MOTOR	1							
88	3	119000-61880	SPACER	3							
89	3	121855-61910	BOLT, LIMITER	1							
90	3	119000-61890	WASHER	3							
91	3	22217-050000	WASHER, SPRING 5	3							
92	3	22417-160120	PIN, COTTER 1.6X12	1							
93	3	26116-050252	BOLT, M5X 25 PLATED	3							
94	3	26116-080142	BOLT 8X14	4							
95	3	22417-120120	PIN, COTTER 1.2X12	1							
96	2	171091-61550	ANGLEICH ASSY	1							

N:Old  $\frac{Yes}{No}$  New, Q:Old  $\frac{No}{Yes}$  New, R:Old  $\frac{Yes}{No}$  New, S:Old  $\frac{No}{Yes}$  New, W:Add, Z:Discontinued, F:Interchangeable by set, K:Q'ty Change

++ CONTINUE ++

Copyright (C) YANMAR CO., LTD. All Rights Reserved.

# Fig.15. COVERNOR

Y0003523  
3TN100L-TBZ

719032-51351

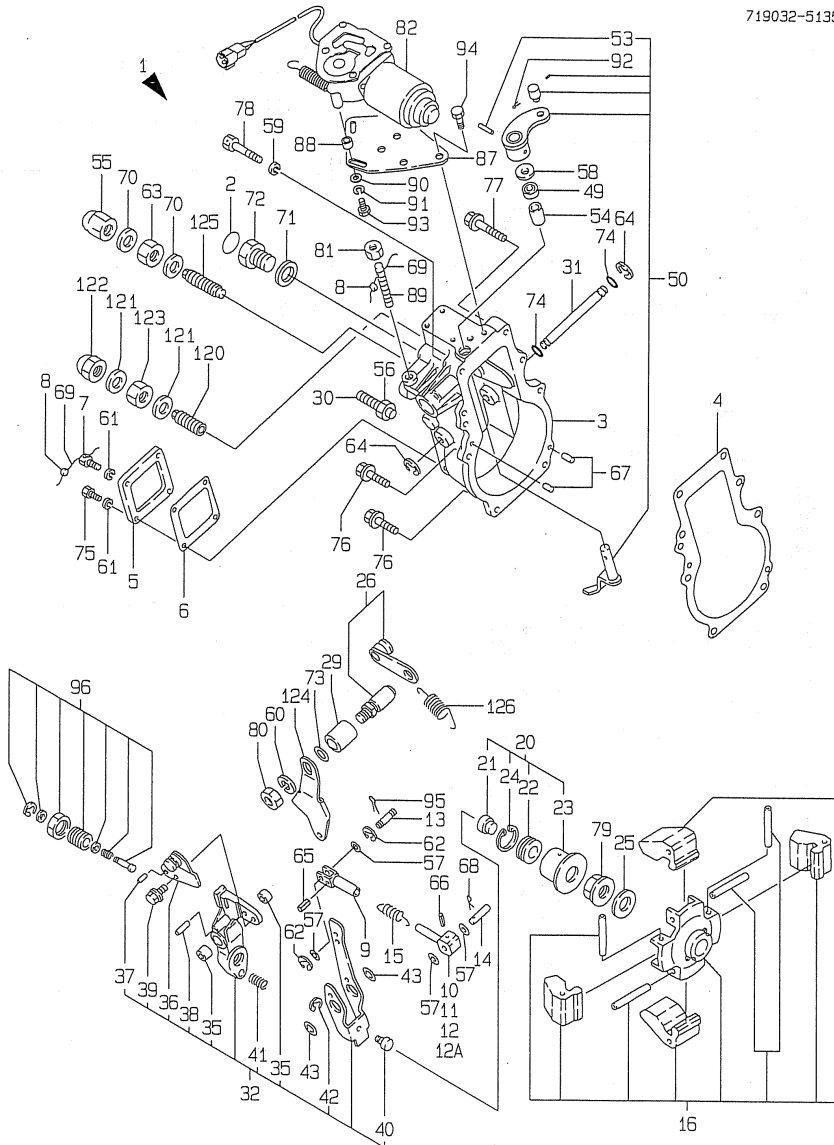

(A)=3TN100L-TBZ  
(B)=  
(C)=

(D)=  
(E)=  
(F)=

No.	Lev.	Parts No.	Description	Q'ty						I	R
				(A)	(B)	(C)	(D)	(E)	(F)		
120	2	26911-080322	SCREW, M8X32	1							
121	2	43400-500420	SEAL WASHER 8	2							
121-1	2	22190-080002	WASHER, SEAL 6	2							N
(A=E11112)											
122	2	26667-080002	NUT, CAP M8	1							
123	2	26757-080002	NUT, LOCK M8	1							
123-1	2	26756-080002	NUT, LOCK M8	1							R
(A=E07901)											
124	2	119000-61440	LEVER, CONTROL	1							
125	2	120323-61470	BOLT, CONTROL	1							
126	2	119032-61700	SPRING, GOVERNOR	1							

Fig.16. STARTING MOTOR

Y00D3523  
3TN100L-TBZ

D19100-77100  
D19032-93020

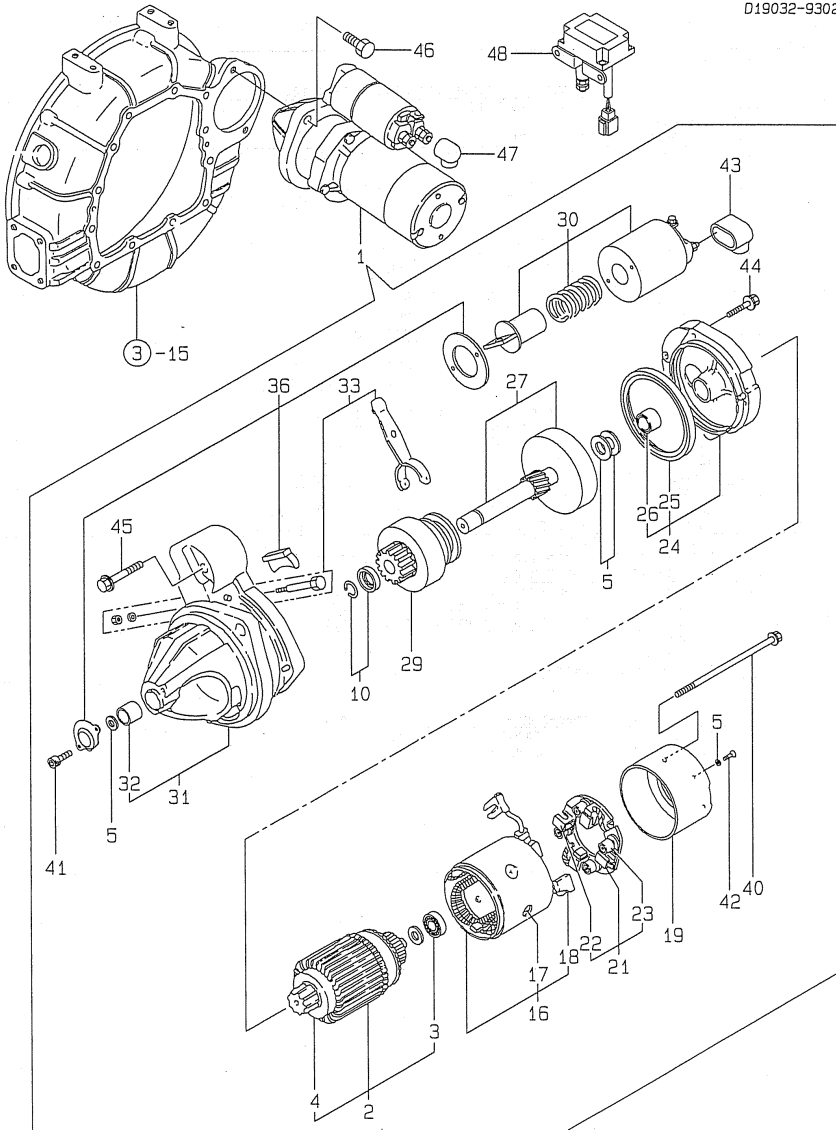

(A)=3TN100L-TBZ

(B)=

(C)=

(D)=

(E)=

(F)=

No.	Lev.	Parts No.	Description	Qty						I	R
				(A)	(B)	(C)	(D)	(E)	(F)		
1	1	121254-77011	STARTER, S13-41A	1							
1-1	1	121254-77012	STARTING MOTOR(DC12V	1							N
(A=E04208)											
2	2	121254-77400	ARMATURE ASSY	1							
2-1	2	121254-77401	ARMATURE ASSY	1							N
(A=E04208)											
3	3	121254-77410	BALL BEARING	1							Z
(A=E04208)											
4	3	121254-77420	BALL BEARING	1							Z
(A=E04208)											
5	2	121254-77430	WASHER KIT, THRUST	1							
10	2	121254-77480	STOPPER KIT, PINION	1							
16	2	121254-77520	COIL ASSY, FIELD	1							
17	3	121254-77530	SCREW, POLE CORE	8							
18	3	121254-77540	BRUSH(+)	2							
19	2	121254-77550	COVER ASSY, REAR	1							
21	2	121254-77570	HOLDER ASSY, BRUSH	1							
22	3	121254-77580	BRUSH (-)	2							
23	3	121254-77590	SPRING	4							
24	2	121254-77600	BEARING ASSY, CENTER	1							
25	3	119129-77210	SEAL, OIL	1							
26	3	119129-77220	BEARING, NEEDLE	1							
27	2	121254-77640	SHAFT ASSY, GEAR	1							
29	2	121254-77661	PINION ASSY	1							
30	2	121254-77670	SWITCH, MAGNETIC	1							
31	2	121254-77681	CASE ASSY, GEAR	1							
32	3	121254-77690	METAL, GEAR CASE	1							
33	2	121254-77700	LEVER SET, SHIFT	1							
36	2	121254-77730	DUST COVER SET	1							
40	2	121254-77770	BOLT, THROUGH	2							
41	2	26450-050122	BOLT, M5X 12	2							
42	2	121254-77790	SCREW 4	2							
43	2	121254-77810	COVER, TERMINAL	1							
44	2	26106-060302	BOLT, M6X 30 PLATED	3							
45	2	26106-060452	BOLT, M6X 45 PLATED	2							
46	1	26116-120302	BOLT, M12X 30 PLATED	2							
47	1	124550-77030	COVER, TERMINAL	1							
48	1	129136-77100	RELAY, SAFETY	1							W
(A=E05448)											



Fig.17. GENERATOR

Y0003523  
37N100L-TBZ

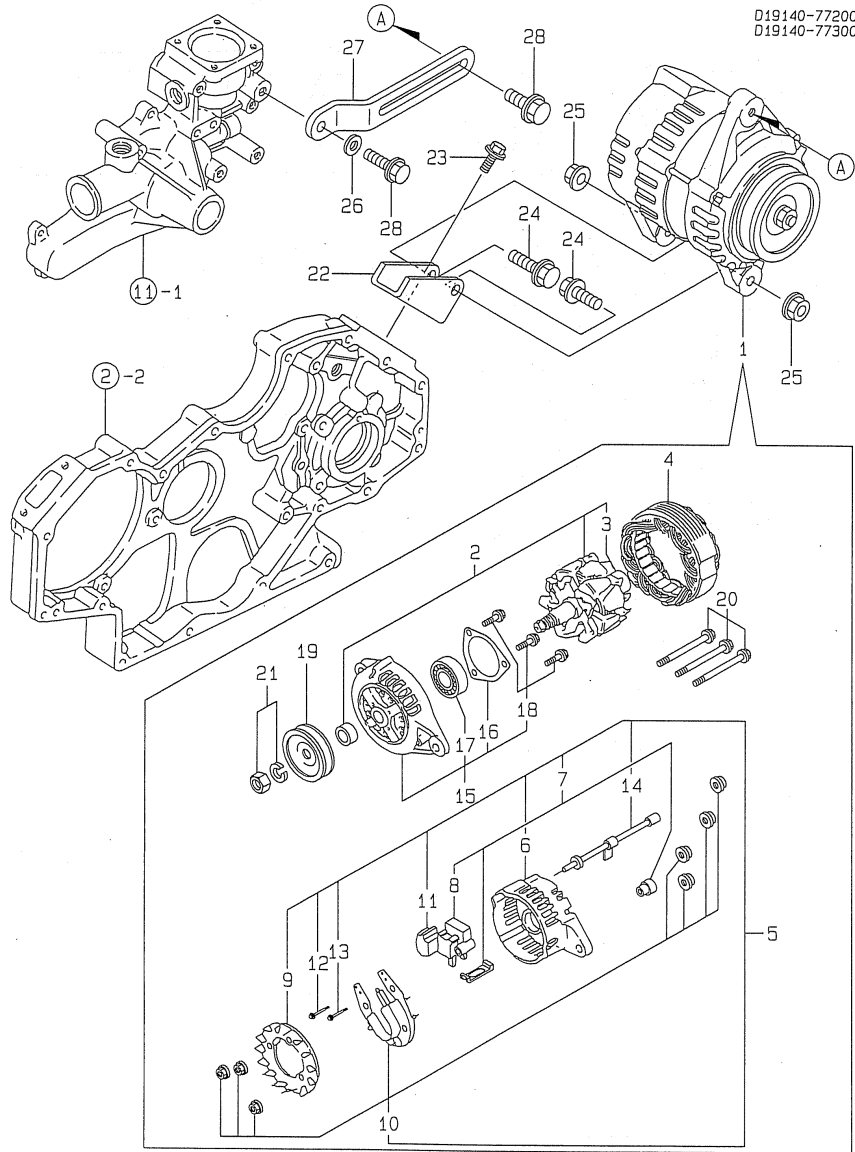

(A)=3TN100L-TBZ

(B)=

(C)=

(D)=

(E)=

(F)=

No.	Lev.	Parts No.	Description	Q'ty						I	R
				(A)	(B)	(C)	(D)	(E)	(F)		
1	1	119836-77200	GENERATOR	1							
2	2	119836-77700	ROTOR ASSY	1							
3	3	119836-77850	BALL BEARING	1							
4	2	119836-77710	STATOR ASSY	1							
5	2	119836-77721	COVER ASSY, REAR	1							
6	3	119836-77730	COVER, REAR	1							
7	3	119836-77741	BRUSH ASSY,REGULATOR	1							
8	4	119836-77750	BRUSH ASSY	1							
9	3	119836-77760	GUIDE, FAN SIDE	1							
10	3	119836-77770	DIODE ASSY	1							
11	3	119836-77780	CONDENSER	1							
12	3	119836-77871	BOLT (1)	1							
13	3	119836-77880	BOLT (2)	1							
14	3	119836-77890	WIRE ASSY, LEAD	1							
15	2	119836-77790	COVER ASSY, FRONT	1							
16	3	119836-77800	RETAINER, BEARING	1							
17	3	119836-77840	BALL BEARING	1							
18	3	119836-77860	SCREW KID	1							
19	2	119836-77810	PULLEY	1							
20	2	119836-77830	BOLT, THROUGH	3							
21	2	119836-77820	NUT ASSY, PULLEY	1							
22	1	119005-77340	BRACKET, GENERATOR	1							
23	1	26106-080202	BOLT, M8X 20 PLATED	2							
24	1	26106-080302	BOLT, M8X 30 PLATED	2							
25	1	26366-080002	NUT, M8	2							
26	1	106100-55800	WASHER	1							
27	1	121857-77330	ADJUSTER	1							
28	1	26106-080202	BOLT, M8X 20 PLATED	2							

Fig.18. TOOL & GASKET SET(OPTIONAL)

Y0003523  
3TN100L-TBZ

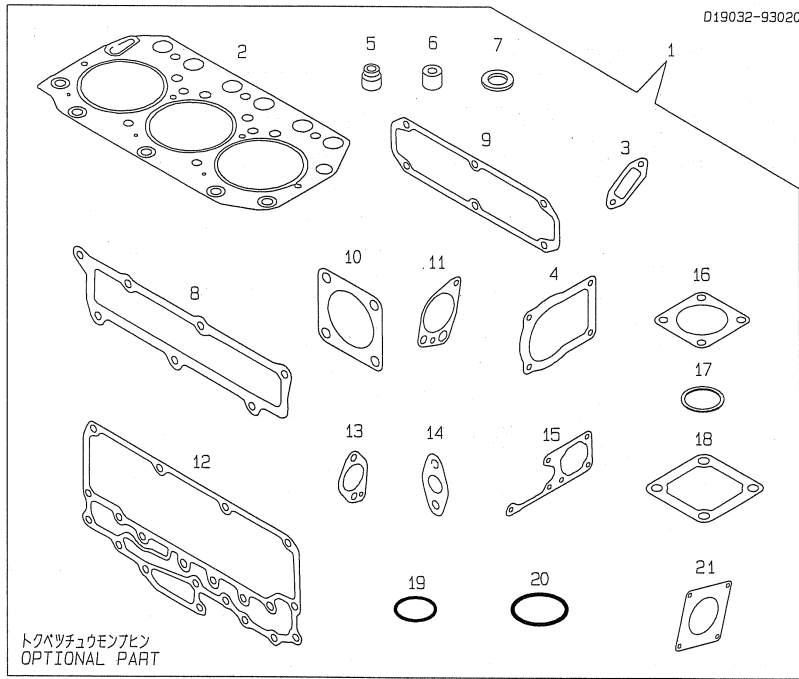

トクバツチュウモンアピン  
OPTIONAL PART

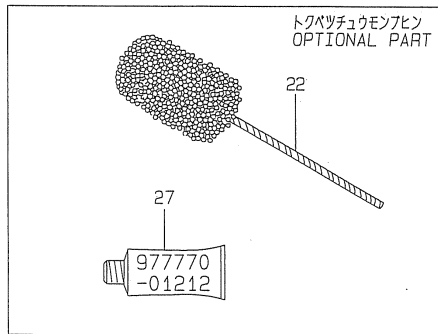
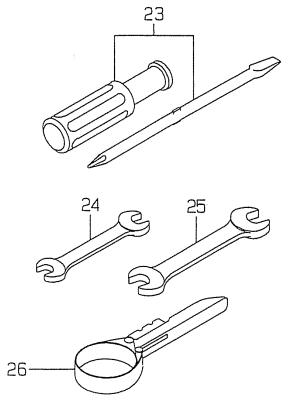

トクバツチュウモンアピン  
OPTIONAL PART

(A)=3TN100L-TBZ

(B)=

(C)=

(D)=

(E)=

(F)=

No.	Lev.	Parts No.	Description	Q'ty						I	R
				(A)	(B)	(C)	(D)	(E)	(F)		
1	1	719032-92600	GASKET SET	1							1
1-1	1	719032-92601	GASKET SET	1							N 1
		(A=EXXX)									
1-2	2	719032-92603	GASKET SET	1							N 1
		(A=E11112)									
2	2	119000-01340	GASKET, HEAD T=1.3	1							
3	2	119000-01770	GASKET	1							
3-1	2	119000-01771	GASKET	1							N
		(A=E03907)									
4	2	124610-01861	GASKET	1							
4-1	2	124610-01862	GASKET	1							N
		(A=E03907)									
5	2	121850-11150	SEAL, VALVE STEM	6							
6	2	119625-11870	PROTECTOR, NOZZLE	3							
7	2	119625-11880	SEAT, NOZZLE	3							
8	2	119000-12110	GASKET, MANIFOLD	1							
9	2	119000-13200	GASKET	1							
10	2	129400-13200	GASKET, SILENCER	1							
10-1	2	129400-13201	GASKET, SILENCER	1							N
		(A=E03907)									
11	2	119000-32020	GASKET, PUMP	1							
12	2	119000-33020	GASKET	1							
12-1	2	119000-33021	GASKET	1							N
		(A=E03907)									
12-2	2	119000-33022	GASKET	1							N
		(A=E11112)									
13	2	119000-33040	GASKET	1							
13-1	2	119000-33041	GASKET	1							N
		(A=E03907)									
14	2	121952-33070	GASKET, COOLER	2							
14-1	2	121952-33071	GASKET, COOLER	2							N
		(A=E03907)									
15	2	119000-42020	GASKET, WATER PUMP	1							
15-1	2	119000-42021	GASKET, WATER PUMP	1							N
		(A=E03907)									
16	2	121850-49540	GASKET, THERMOSTAT	1							
17	2	121850-49550	GASKET, THERMOSTAT	1							
18	2	121850-77020	GASKET	1							
18-1	2	121850-77021	GASKET	1							N
		(A=E03907)									
19	2	24311-000320	O-RING, 1AP32.0	1							
20	2	24311-000360	O-RING, 1AP36.0	1							
21	2	124240-01883	GASKET	1							
22	1	129400-92450	HONE	1							1
23	1	104200-92350	DRIVER, SCREW	1							
24	1	28110-100120	SPANNER, 10X12	1							
25	1	28110-140170	SPANNER, 14X17	1							
26	1	127610-92750	WRENCH, FILTER	1							
27	1	977770-01212	GASKET, LIQUID	1							W 1
		(A=EXXX)									

Remarks  
(1) OPTIONAL PART.

## Parts No. Index

Parts No.	Fig. No.	Ref. No.
101304-59020	14	4
		17
101720-55750	14	50
102103-55520	14	44
103854-59191	14	6
103854-59201	14	7
104200-55321	14	40
104200-55330	14	41
104200-55341	14	42
104200-55750	14	51
104200-92350	18	23
106100-55800	12	97
	17	26
110250-55610	14	45
114250-53080	13	5
114250-53120	13	9
114250-53130	13	10
114250-53140	13	11
114250-53210	13	12
		12 -1
114250-53400	13	13
119000-01200	1	28
119000-01340	1	29
	18	2
119000-01730	3	5
119000-01740	2	5
119000-01770	2	6
	18	3
119000-01771	2	6 -1
	18	3 -1
119000-01780	3	1
119000-01840	1	11
119000-01930	2	18
119000-01980	1	30
119000-02020	1	19
119000-02410	1	5
119000-02450	7	2
119000-02800	1	22
119000-02930	1	25
119000-03200	4	43
119000-07200	4	49
119000-11110	4	15
119000-11170	4	8
119000-11230	4	27
119000-11240	4	24
119000-11260	4	30
119000-11270	4	31
119000-11280	4	32
119000-11290	4	33
119000-11311	4	42

Parts No.	Fig. No.	Ref. No.
119000-11320	4	47
119000-12100	5	1
119000-12110	5	2
	18	8
119000-13100	6	1
119000-13200	6	2
	18	9
119000-14000	7	1
119000-14100	7	4
119000-14200	7	6
119000-21650	8	7
119000-22000	8	15
119000-22300	8	23
119000-23910	8	31
119000-25050	7	9
119000-25100	7	10
119000-25900	12	93
119000-25910	12	94
119000-25920	12	95
119000-25930	7	14
119000-32001	9	1
119000-32020	9	17
	18	11
119000-33010	10	2
119000-33020	10	16
	18	12
119000-33021	10	16 -1
	18	12 -1
119000-33022	10	16 -2
	18	12 -2
119000-33030	10	17
119000-33040	10	18
	18	13
119000-33041	10	18 -1
	18	13 -1
119000-33050	10	3
119000-34030	10	5
119000-35140	9	21
119000-39350	10	24
	12	83
119000-39650	9	26
119000-42020	11	17
	18	15
119000-42021	11	17 -1
	18	15 -1
119000-42250	11	22
119000-48170	11	24
119000-51030	12	4
119000-51050	12	5
119000-51060	12	7

Parts No.	Fig. No.	Ref. No.
119000-51081	12	8
119000-51091	12	9
119000-51101	12	10
119000-51161	12	17
119000-51170	12	18
119000-51181	12	79
119000-51201	12	19
119000-51330	12	30
119000-51340	12	31
119000-51360	12	33
119000-51410	12	34
119000-51450	12	35
119000-51500	12	42
119000-51510	12	43
119000-51530	12	44
119000-51550	12	45
119000-51570	12	46
119000-51580	12	47
119000-51590	12	48
119000-51650	12	49
119000-51800	12	62
119000-51900	12	64
119000-51911	12	66
119000-51990	12	80
119000-53000	13	2
119000-55600	14	1
119000-59550	14	21
119000-59560	14	22
119000-61011	15	3
119000-61050	15	4
119000-61051	15	4 -1
119000-61080	15	12 A
119000-61120	15	9
119000-61140	15	10
119000-61150	15	11
119000-61160	15	12
119000-61170	15	13
119000-61180	15	14
119000-61190	15	15
119000-61200	15	16
119000-61300	15	20
119000-61310	15	21
119000-61320	15	22
119000-61340	15	23
119000-61380	15	25
119000-61400	15	26
119000-61430	15	29
119000-61440	15	124
119000-61470	15	56
119000-61490	15	31

Parts No.	Fig. No.	Ref. No.
119000-61500	15	32
119000-61530	15	35
119000-61540	15	36
119000-61560	15	37
119000-61561	15	37 -1
119000-61630	15	43
119000-61801	15	50
119000-61841	15	54
119000-61870	15	87
119000-61880	15	88
119000-61890	15	90
119001-52000	12	84
119005-35100	9	20 -1
119005-77340	17	22
119006-01590	2	14
119006-42000	11	1
119006-42001	11	1 -1
119023-61000	15	1
119032-01601	3	15 -1
119032-12250	5	10
119032-12260	5	11
119032-12500	5	13
119032-13500	6	7
119032-13570	6	12
119032-13571	6	12 -1
119032-13650	6	8
119032-44500	11	35
119032-44501	11	35 -1
119032-44590	11	40
119032-44591	11	40 -1
119032-61700	15	126
119032-61850	15	82
119100-01640	3	10
119100-11330	4	45
119100-26200	2	34
119100-34800	3	19
119100-35090	9	22
119100-35100	9	20
119100-59820	13	25
119100-59830	13	29
119100-59840	13	33
119100-61430	15	29 -1
119129-77210	16	25
119129-77220	16	26
119130-01600	3	15
119130-21590	8	12
119130-44760	11	32
119130-49020	11	43
119141-21650	8	7 -1
119620-01750	3	16

## Parts No. Index

Parts No.	Fig. No.	Ref. No.
119625-11870	4	36
	18	6
119625-11880	4	37
	18	7
119625-11900	4	38
119640-01640	3	3 -2
119836-77200	17	1
119836-77700	17	2
119836-77710	17	4
119836-77721	17	5
119836-77730	17	6
119836-77741	17	7
119836-77750	17	8
119836-77760	17	9
119836-77770	17	10
119836-77780	17	11
119836-77790	17	15
119836-77800	17	16
119836-77810	17	19
119836-77820	17	21
119836-77830	17	20
119836-77840	17	17
119836-77850	17	3
119836-77860	17	18
119836-77871	17	12
119836-77880	17	13
119836-77890	17	14
120323-61060	15	5
120323-61070	15	6
120323-61470	15	125
120445-44530	11	37
120445-44540	11	38
121023-01550	2	15
121120-12561	5	16
121120-12571	5	17
121250-39450	10	27
121250-44901	11	29
121254-55510	14	43
121254-77011	16	1
121254-77012	16	1 -1
121254-77400	16	2
121254-77401	16	2 -1
121254-77410	16	3
121254-77420	16	4
121254-77430	16	5
121254-77480	16	10
121254-77520	16	16
121254-77530	16	17
121254-77540	16	18
121254-77550	16	19

Parts No.	Fig. No.	Ref. No.
121254-77570	16	21
121254-77580	16	22
121254-77590	16	23
121254-77600	16	24
121254-77640	16	27
121254-77661	16	29
121254-77670	16	30
121254-77681	16	31
121254-77690	16	32
121254-77700	16	33
121254-77730	16	36
121254-77770	16	40
121254-77790	16	42
121254-77810	16	43
121257-55720	14	48
121257-55731	14	49
121258-12600	5	19
121262-12800	5	20
121423-13580	6	13
121492-12700	5	15
121520-34810	3	20
121550-49111	11	34
121750-59890	14	5
121850-01800	2	14 B
		17
121850-01900	12	92
121850-01920	2	4
		23
121850-11100	4	14
121850-11120	4	16
121850-11150	4	17
	18	5
121850-11160	4	7
121850-11180	4	18
121850-12510	5	18
121850-12530	5	14
121850-21130	8	11
121850-21200	8	4
121850-21290	8	5
121850-21660	8	8
121850-21680	8	9
121850-21920	8	6 B
		10
121850-23200	8	28
121850-35230	10	15
121850-49530	11	25
121850-49540	11	26
	18	16
	18	16
121850-49550	11	27
	18	17

Parts No.	Fig. No.	Ref. No.
121850-51700	12	61
121850-55710	14	47
121850-55800	14	39
121850-61600	15	41
121850-77020	5	6
	18	18
121850-77021	5	6 -1
	18	18 -1
121850-77050	5	7
121855-59880	14	11
121855-61910	15	89
121857-77330	17	27
121950-44741	11	31
121952-33070	10	4
	18	14
121952-33071	10	4 -1
	18	14 -1
121952-39830	10	7
121952-51900	12	65
121970-49010	11	42
122710-51050	12	6
122710-51350	12	32
122710-51920	12	67
123372-59080	13	20
123385-82200	4	9
123672-84530	10	9
124060-59380	14	8
124066-59100	14	18
124160-01751	4	40
124223-35510	10	8
124240-01871	2	16
124240-01883	2	19
	18	21
124250-11190	4	19
124410-51860	12	85
124410-51861	12	85 -1
		85 -2
124410-51960	12	96
124411-01780	3	12
124411-35520	10	6
124450-44590	11	36
124465-44950	11	30
124550-21600	8	14
124550-77030	16	47
124610-01851	2	7
124610-01861	2	8
	18	4
124610-01862	2	8 -1
	18	4 -1
124610-51970	15	2

Parts No.	Fig. No.	Ref. No.
124616-61540	15	40
124976-34850	3	14
127420-44560	11	39
127610-92750	18	26
128400-51300	12	27
129052-96150	11	23 -1
129100-01580	1	12
		13
		14
	2	9
129100-59951	14	25
129100-61930	15	55
129100-77820	5	8
129129-59510	14	10
129136-77100	16	48
129150-03100	4	2
129150-11750	4	28
129150-14400	7	7
129150-49080	11	46
129150-49100	11	44
129150-49360	11	18
129150-59580	14	23
129155-51270	12	25
129155-51280	12	26
129155-61090	15	7
129155-61460	15	30 -1
129255-59580	14	24
129322-77401	14	38
129400-13200	6	6
	18	10
129400-13201	6	6 -1
	18	10 -1
129400-92450	18	22
129470-55610	14	2
129470-59530	14	20
129470-61450	15	30
129495-59300	14	19
135210-61090	15	8
135400-01790	1	10
135602-34390	1	18
137600-53900	12	71
144626-51090	12	63
144626-51940	12	68
144626-51950	12	69
148616-61650	15	49
152623-51860	12	88
171051-01921	1	4
171056-49351	11	19
171087-42280	11	23
171091-13660	6	9

## Parts No. Index

Parts No.	Fig. No.	Ref. No.
171091-13670	6	10
171091-13680	6	11
171091-44900	11	41
171091-61550	15	96
171301-01640	3	3
		3 -1
171350-03090	4	1
22117-050000	15	57
22137-080000	15	58
22190-060000	12	72
22190-060002	14	9 -1
22190-080002	15	121 -1
22190-080003	2	12 -1
22190-120002	14	13 -2
		35 -2
	15	70 -1
22190-140002	14	14 -2
		36 -2
22190-160002	15	71 -1
22190-220002	3	4 -2
22217-050000	15	61
		91
22217-060000	12	86
	15	59
22217-100000	15	60
22217-180000	12	98
22242-000180	4	34
22252-000340	8	24
22262-000260	15	24
22272-000040	15	42
		62
22272-000080	15	64
22351-020012	15	38 -1
22351-020016	15	38
22351-030010	9	27
22351-030016	15	53
		65
22351-030025	15	66
22351-050012	12	99
22351-050020	15	67
22351-080016	1	15
22360-050000	15	68
22372-050000	15	68 -1
22417-120120	15	95
22417-160120	15	92
22451-100000	15	69
22453-060000	15	69 -1
22512-070140	7	5
	8	42
23000-013000	14	12

Parts No.	Fig. No.	Ref. No.
23000-013000	14	33
23000-022000	4	3
23000-070000	5	12
23010-050000	11	49
23414-080000	10	25
	12	81
	14	34
23414-100000	1	16
23414-120000	14	13
		35
23414-140000	1	17
	14	14
		36
23414-160000	10	10
23414-180000	10	11
23414-220029	12	73
23418-060000	14	52
23857-030000	9	28
	10	26
	12	82
23857-060000	14	15
23857-080000	14	16
23871-030000	1	6
	4	10
	10	12
	11	12
23887-160002	10	13
	15	72
24101-060064	2	35
24105-060064	2	35 -1
24311-000110	15	73
24311-000220	9	23
24311-000320	4	41
	18	19
24311-000360	11	20
	18	20
24311-240100	14	53
24312-000150	12	74
24341-000080	15	74
24341-000240	2	20
	3	4
		4 -1
24341-000260	12	70
24341-000500	12	75
24341-001350	12	100
26013-080162	9	24
26013-080452	7	13
26014-060142	11	28
26014-080452	11	33
26022-050122	4	46

Parts No.	Fig. No.	Ref. No.
26106-060122	15	39
26106-060182	2	21
	12	76
26106-060202	12	16
	13	22
26106-060222	15	76
26106-060302	16	44
26106-060352	15	77
26106-060452	16	45
26106-080102	14	37
26106-080162	1	31
	7	8
	9	18
		25
26106-080182	2	25
26106-080202	2	10
		22
		26
	5	3
	10	19
		20
	17	23
		28
26106-080252	2	33
	3	6
		13
	4	48
	12	101
26106-080302	17	24
26106-080352	2	36
	3	7
	5	9
	10	21
		22
26106-080402	2	27
	6	3
26106-080452	2	28
		29
26106-080502	6	4
	9	19
	10	23
26106-080552	2	30
26106-080652	4	39
	11	21
26106-080702	3	8
	5	4
26106-080752	2	31
26106-080802	3	9
26106-080902	2	32
26106-081152	5	5

Parts No.	Fig. No.	Ref. No.
26106-100202	4	50
26106-100252	3	17
	14	3
26106-100302	3	18
26106-100652	6	14
26116-050102	15	75
26116-050252	15	93
26116-060356	15	78
26116-080142	15	94
26116-120302	16	46
26216-060162	12	77
26216-060252	4	20
26216-080222	6	5
26216-080652	4	21
26366-060002	4	22
	13	23
26366-080002	2	11
		24
	4	23
	12	78
	17	25
26366-100002	12	90
26376-100002	10	14
26376-120002	15	79
26450-050122	16	41
26606-100002	15	80 -1
26667-080002	15	122
26706-100002	6	15
26716-060002	12	87
26736-100002	15	80
26756-080002	15	81 -1
		123 -1
26757-080002	15	81
		123
26776-180002	12	91
26777-120002	15	63
26911-080322	15	120
27231-600000	1	7
27241-140000	1	8
27241-160000	4	11
27241-280000	4	12
27241-400000	1	9
	4	13
28110-100120	18	24
28110-140170	18	25
43400-500390	14	9
43400-500420	2	12
	15	121
43400-500450	14	13 -1
		35 -1

# Parts No. Index

Parts No.	Fig. No.	Ref. No.
43400-500450	15	70
43400-500470	14	14 -1
		36 -1
43400-500500	15	71
719000-01560	1	1
719000-02870	1	32
719000-02940	1	35
719000-11650	4	25
719000-11700	4	4
719000-21700	8	1
719000-22500	8	17
719000-22900	8	32
719000-22950	8	34
719000-23100	8	25
719000-23600	8	29
719000-23610	8	40
719000-33700	10	1
719000-53100	13	1
719032-51351	12	1
719032-92600	18	1
719032-92601	18	1 -1
719032-92603	18	1 -2
719129-01500	2	2
719129-01601	2	13
719129-01611	2	1
977770-01212	18	27

Parts No.	Fig. No.	Ref. No.
-----------	----------	----------

Parts No.	Fig. No.	Ref. No.
-----------	----------	----------

Parts No.	Fig. No.	Ref. No.
-----------	----------	----------