

0CC50-M00790EN

Introduction

1. This parts catalog is a first edition of the TF160LE diesel engine.

	Date of issue	Remarks
First edition	Mar., 2016	

2. This parts catalog does not contain the technical data needed for maintenance service.

3. The illustrations used in this parts catalog have been simplified for clarity.

4. The contents of this parts catalog are subject to change without notice.

5. Be sure to use only Yanmar genuine parts for repairs. If imitation parts are used, it may cause engine defects.

Contents

OCC50-M00790

Fig. No. Fig. Name

Fig. No. Fig. Name

TF160LE

1. CYLINDER BLOCK
2. BREATHER
3. ENGINE BED
4. CYLINDER HEAD & BONNET
5. AIR CLEANER & MUFFLER
6. CAMSHAFT
7. CRANKSHAFT & FLYWHEEL
8. PISTON & CONNECTING ROD
9. BALANCER
10. LUB. OIL SYSTEM
11. RADIATOR
12. FAN
13. FUEL INJECTION PUMP
14. FUEL INJECTION DEVICE
15. FUEL TANK
16. GOVERNOR & CONTROL EQUIPMENT
17. STARTING DEVICE
18. STARTER MOTOR
19. LAMP
20. LABEL
21. TOOL
22. BUNDLED ITEMS

Fig.1. CYLINDER BLOCK

(A)=TF160LE
(B)=
(C)=

(D)=
(E)=
(F)=

No.	Lev.	Parts No.	Description	Qty						I	R
				(A)	(B)	(C)	(D)	(E)	(F)		
1	1	705700-01561	BLOCK ASSY, CYLINDER	1							
4	2	22351-060012	PIN, SPRING 6.0X12	2							
5	1	705800-01900	LINER ASSY, CYLINDER	1							
8	2	105700-01300	O-RING	2							
9	1	103854-01200	BOLT, HEAD	4							
10	1	103854-01221	NUT, CYLINDER HEAD	4							
11	1	104700-01240	WASHER	4							
12	1	10570H-01331	GASKET, HEAD	1							
13	1	10570H-01392	CASE ASSY, GEAR	1							
19	1	105100-01660	PLUG, 14	1							
20	1	22351-060012	PIN, SPRING 6.0X12	1							
21	1	105300-34040	SPRING	1							
22	1	22252-000100	RING, 10	1							
23	1	24190-120001	BALL, STEEL 3/8	1							
24	1	10571H-61250	SEAL,OIL START SHAFT	1							
25	1	105700-01410	GASKET, GEAR CASE	1							
26	1	10550H-01481	COVER, REAR	1							
27	1	10550H-01490	GASKET, REAR COVER	1							
28	1	105300-01690	PLUG	1							
29	1	10570H-01750	CAP, DIPSTICK	1							
30	1	101104-01760	GASKET, CAP	1							
31	1	10570H-01850	SHIM ASSY,F.I.TIMING	1							
45	1	24311-000060	O-RING, 1AP6.0	1							
46	1	24321-000250	O-RING, 1AG25.0	1							
47	1	26106-060142	BOLT, M6X 14 PLATED	10							
48	1	26106-080352	BOLT, M8X 35 PLATED	7							
49	1	26106-080752	BOLT, M8X 75 PLATED	6							
50	1	26216-080222	STUD, M8X 22	3							
51	1	26366-080002	NUT, M8	3							

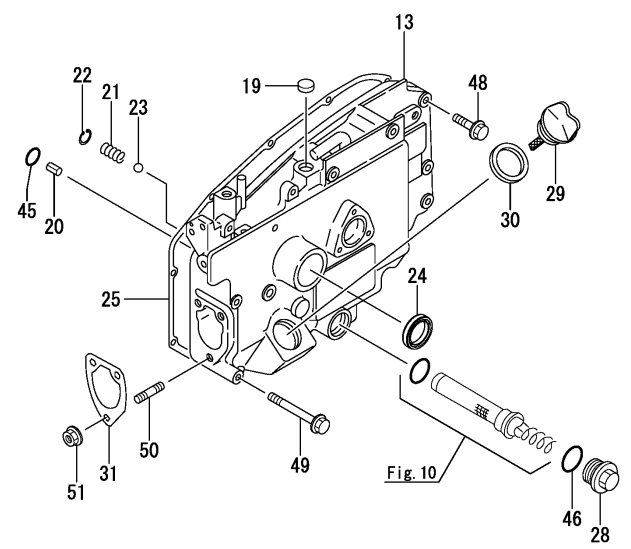
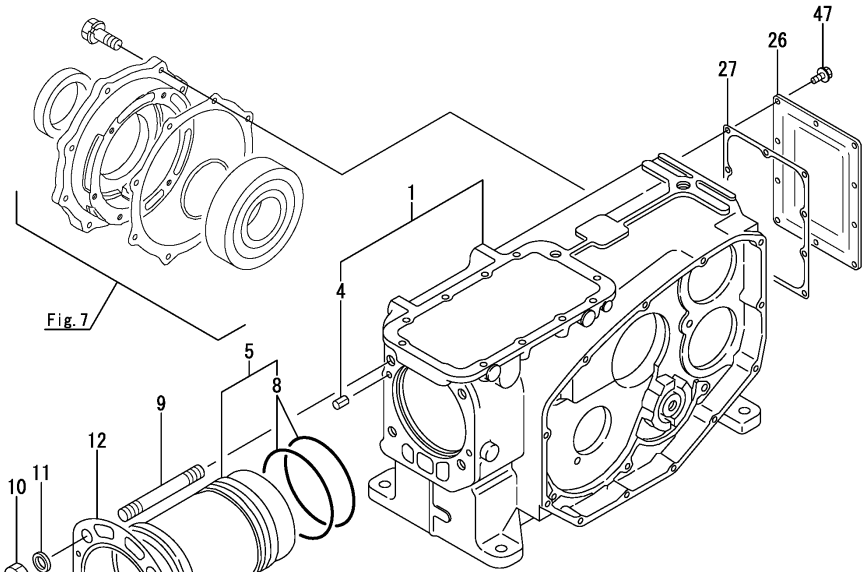

(A)=TF160LE
 (B)=
 (C)=

(D)=
 (E)=
 (F)=

No.	Lev.	Parts No.	Description	Q'ty						I	R
				(A)	(B)	(C)	(D)	(E)	(F)		
1	1	10570H-03070	COVER ASSY, BREATHER	1							
2	2	10537H-03060	VALVE, RETURN	1							
4	2	101158-03111	RETAINER	1							
5	2	105362-78960	SCREW, M4X8	2							
6	2	22217-040000	WASHER, SPRING 4	2							
7	1	105700-03132	GASKET	1							
8	1	23064-110450	HOSE, 11 X 450	1							
9	1	26106-060222	BOLT, M6X 22 PLATED	4							

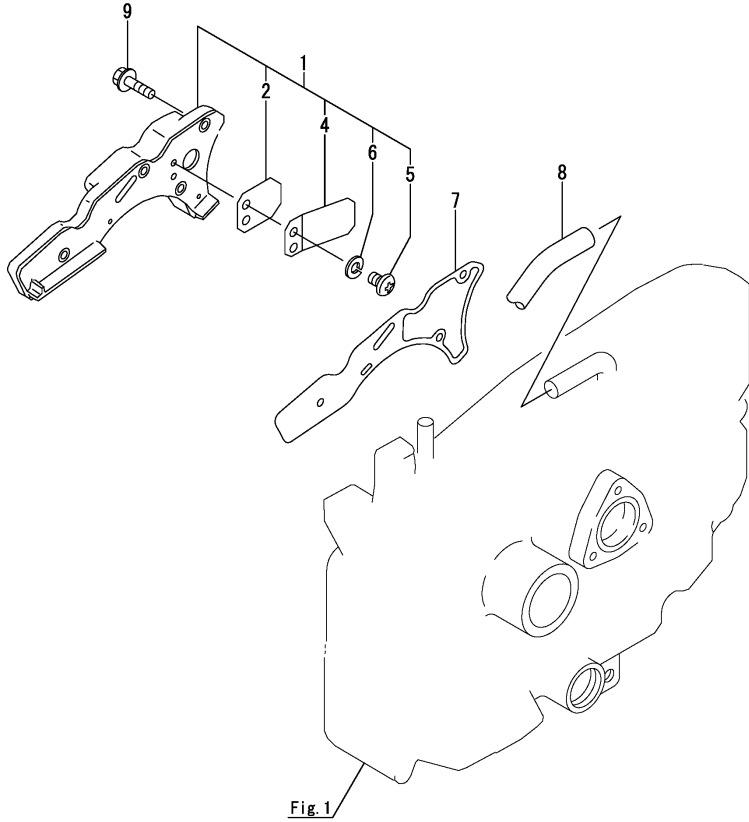

Fig.4. CYLINDER HEAD & BONNET

(A)=TF160LE

(B)=

(C)=

(D)=

(E)=

(F)=

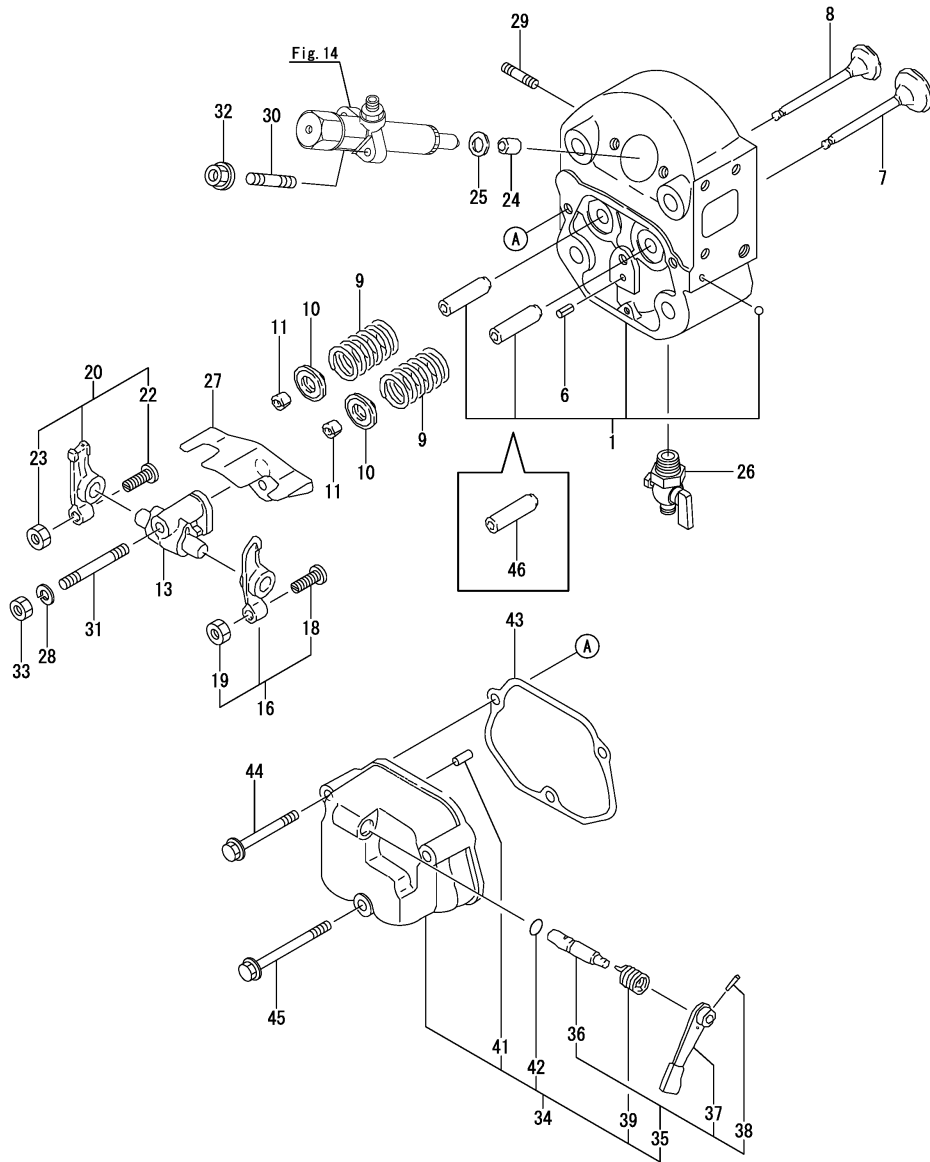

No.	Lev.	Parts No.	Description	Q'ty						I	R
				(A)	(B)	(C)	(D)	(E)	(F)		
1	1	705706-11701	HEAD ASSY, CYLINDER	1							
6	2	105300-11330	PIN	1							
7	1	105700-11100	VALVE, INTAKE	1							
8	1	105700-11111	VALVE, EXHAUST	1							
9	1	10570H-11120	SPRING, VALVE	2							
10	1	103854-11180	RETAINER, SPRING	2							
11	1	103854-11191	COTTER	2							
13	1	105700-11290	SUPPORT ASSY, ARM	1							
16	1	10570H-11650	ARM ASSY, INTAKE	1							
18	2	103854-11230	SCREW, VALVE ADJUST	1							
19	2	26796-100002	NUT, LOCK M10	1							
20	1	10570H-11660	ARM ASSY, EXHAUST	1							
22	2	103854-11230	SCREW, VALVE ADJUST	1							
23	2	26796-100002	NUT, LOCK M10	1							
24	1	128610-11900	INSULATOR	1							
25	1	10570H-11910	GASKET, NOZZLE	1							
26	1	105010-11920	COCK, WATER	1							
27	1	10570H-11940	PLATE, BAFFLE	1							
28	1	22217-100000	WASHER, SPRING 10	1							
29	1	26216-080222	STUD, M8X 22	4							
30	1	26216-080502	STUD, M8X 50	2							
31	1	26216-100552	STUD, M10X 55	1							
32	1	26366-080002	NUT, M8	2							
33	1	26716-100002	NUT, M10	1							
34	1	10570G-11650	BONNET SUB ASSY	1							
35	2	10530H-03550	LEVER ASSY, DECOMP.	1							
36	3	10530H-03610	SHAFT, DECOMP LEVER	1							
37	3	104104-03750	LEVER, DECOMPRESSION	1							
38	3	22322-030160	PIN, TAPER 3X16	1							
39	2	104200-03641	SPRING, DECOMPRESSION	1							
41	2	22312-030180	PIN, PARALLEL M3X18	1							
42	2	24311-000070	O-RING, 1AP7.0	1							
43	1	10570H-11310	PACKING, BONNET	1							
44	1	26106-060552	BOLT, M6X 55 PLATED	1							
45	1	26106-060702	BOLT, M6X 70 PLATED	2							
46	1	105700-11801	GUIDE, VALVE	2							1

Remarks

(1) Spare parts.

N:Old $\begin{matrix} \leftarrow \text{Yes} \\ \text{No} \end{matrix}$ New, Q:Old $\begin{matrix} \leftarrow \text{No} \\ \text{Yes} \end{matrix}$ New, R:Old $\begin{matrix} \leftarrow \text{Yes} \\ \text{Yes} \end{matrix}$ New, S:Old $\begin{matrix} \leftarrow \text{No} \\ \text{No} \end{matrix}$ New, W:Add, Z:Discontinued, F:Interchangeable by set, K:Q'ty Change

Fig.5. AIR CLEANER & MUFFLER

(A)=TF160LE
(B)=
(C)=

(D)=
(E)=
(F)=

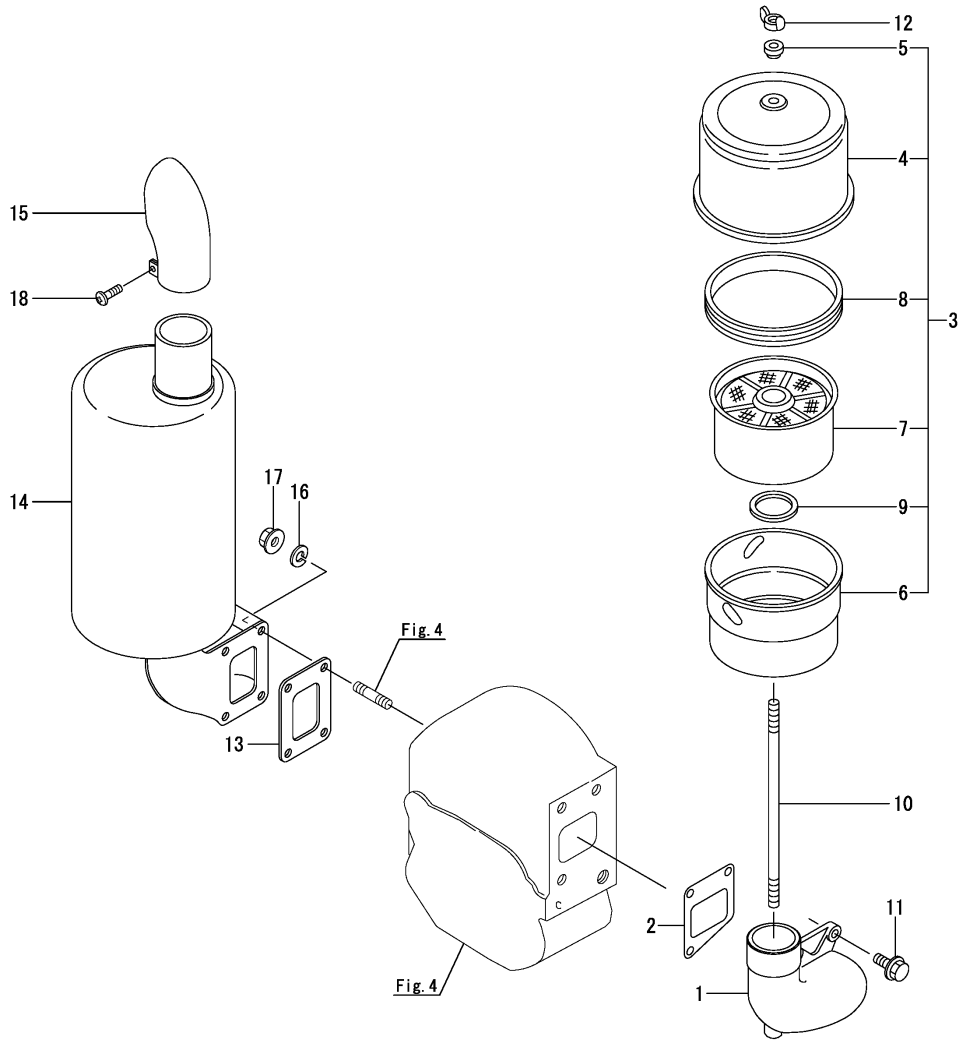

No.	Lev.	Parts No.	Description	Q'ty						I	R
				(A)	(B)	(C)	(D)	(E)	(F)		
1	1	10570H-12021	PIPE, AIR INTAKE	1							
2	1	105700-12050	GASKET	1							
3	1	10570H-12510	CLEANER ASSY, AIR	1							
4	2	10570H-12701	CAP, AIR CLEANER	1							
5	2	10570H-12710	WASHER, SEAL	1							
6	2	10570H-12750	BODY, AIR CLEANER	1							
7	2	10570H-12800	ELEMENT	1							
8	2	10570H-12850	GASKET, CAP	1							
9	2	10570H-12860	GASKET, AIR CLEANER	1							
10	1	10570H-12551	BOLT	1							
11	1	26106-080202	BOLT, M8X 20 PLATED	3							
12	1	26636-080002	NUT, WING M8	1							
13	1	105700-13201	GASKET, SILENCER	1							
14	1	10570H-13519	SILENCER	1							
15	1	10570H-13570	PIPE, EXHAUST	1							
16	1	22217-080000	WASHER, SPRING 8	4							
17	1	26366-080002	NUT, M8	4							
18	1	26557-060202	SCREW, M6X20	1							

Fig.6. CAMSHAFT

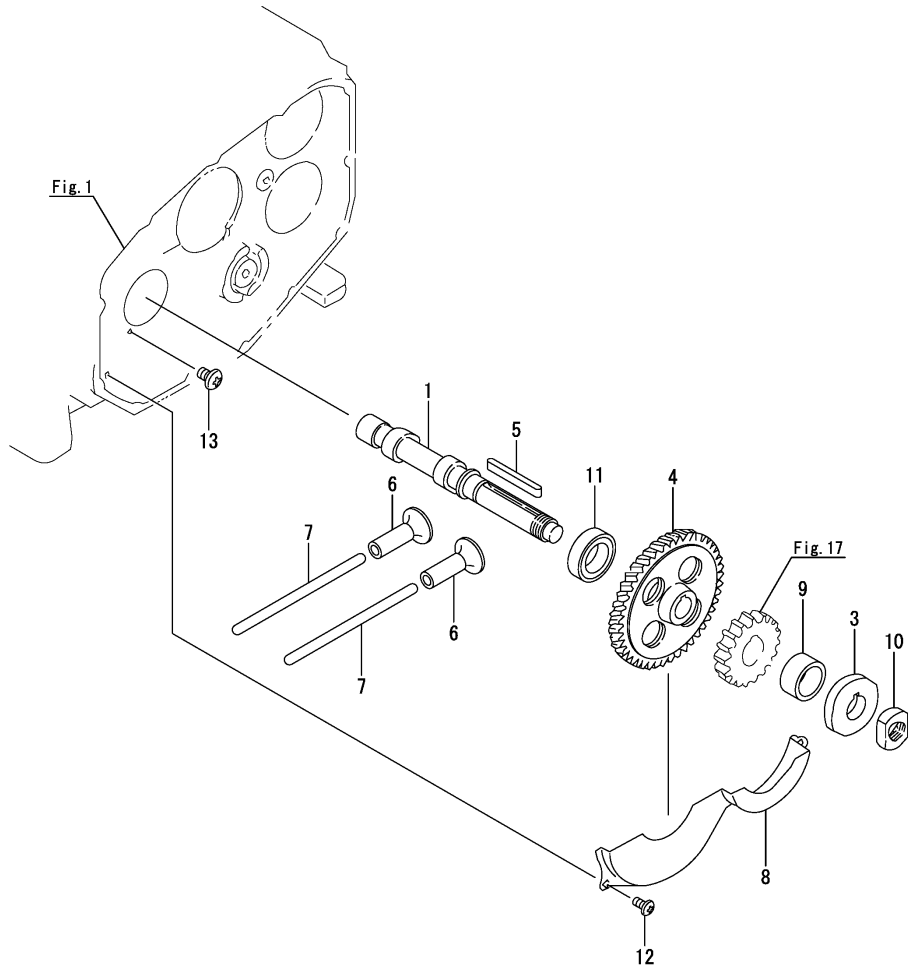

(A)=TF160LE
(B)=
(C)=

(D)=
(E)=
(F)=

No.	Lev.	Parts No.	Description	Q'ty						I	R
				(A)	(B)	(C)	(D)	(E)	(F)		
1	1	105700-14010	CAMSHAFT	1							
3	1	105700-14090	CAM, FUEL	1							
4	1	105700-14100	GEAR, CAMSHAFT	1							
5	1	10537H-14190	KEY, CAMSHAFT GEAR	1							
6	1	103854-14200	TAPPET	2							
7	1	10570H-14400	ROD, PUSH	2							
8	1	105700-14600	COVER	1							
9	1	10570H-14700	SPACER, CAMSHAFT	1							
10	1	104300-76460	NUT	1							
11	1	24101-060064	BEARING, BALL 6006	1							
12	1	26022-060122	SCREW, M6X12	3							
13	1	26587-080122	SCREW, M8X12	1							

Fig.7. CRANKSHAFT & FLYWHEEL

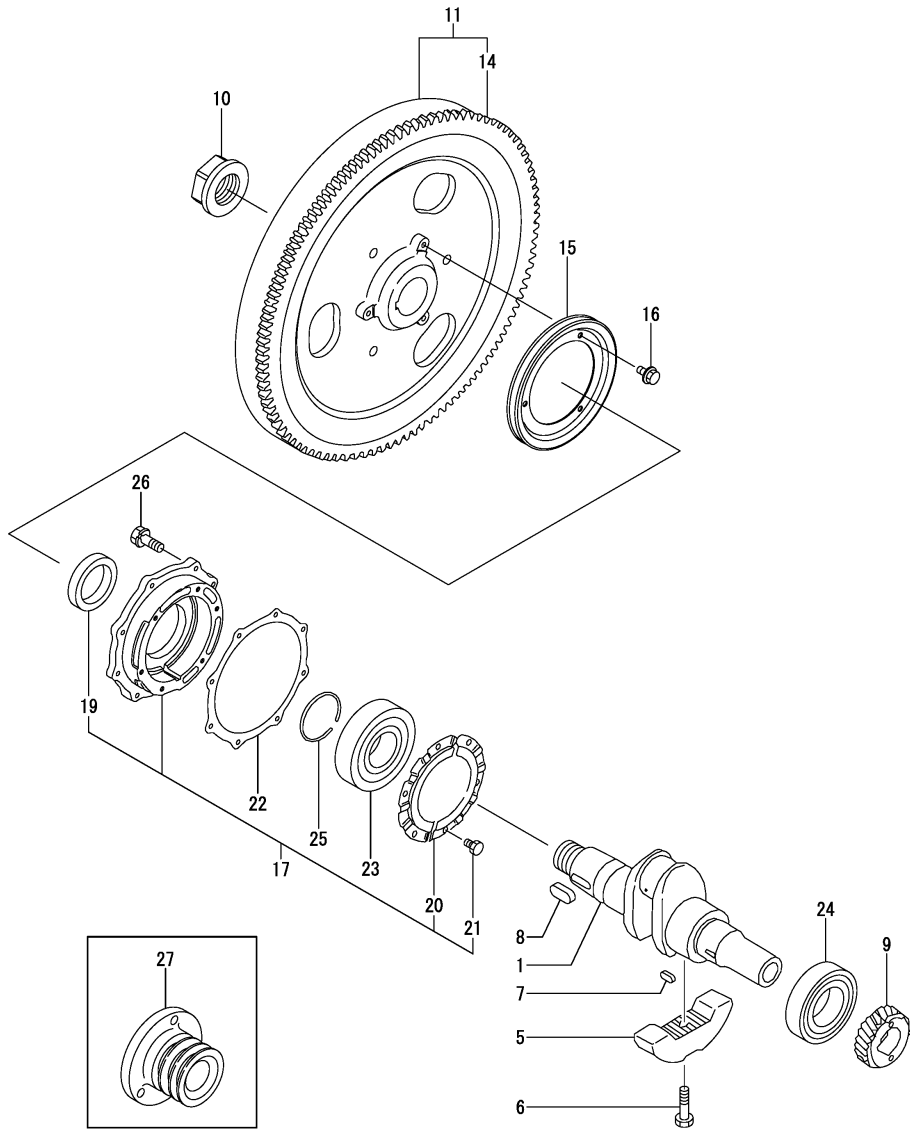

(A)=TF160LE
(B)=
(C)=

(D)=
(E)=
(F)=

No.	Lev.	Parts No.	Description	Q'ty						I	R
				(A)	(B)	(C)	(D)	(E)	(F)		
1	1	105700-21010	CRANKSHAFT	1							
5	1	10570H-21100	WEIGHT, BALANCE	2							
6	1	104600-21130	BOLT	2							
7	1	10570H-21290	KEY	1							
8	1	10557H-21520	KEY, FLYWHEEL	1							
9	1	105700-21200	GEAR, CRANKSHAFT	1							
10	1	10550H-21530	NUT, END	1							
11	1	105700-21591	FLYWHEEL ASSY	1							
14	2	105700-21601	GEAR, RING	1							
15	1	10510H-21600	V-PULLEY	1							
16	1	26106-060122	BOLT, M6X 12 PLATED	3							
17	1	705700-02500	HOUSING ASSY, METAL	1							
19	2	104700-02220	SEAL, OIL	1							
20	2	105700-02320	RETAINER	2							
21	2	26116-060102	BOLT, M6X 10 PLATED	6							
22	1	105700-02020	GASKET	1							
23	1	105800-02300	BEARING, 6312BG3C3	1							
24	1	10570H-02310	BEARING	1							
25	1	22242-000600	RING, 60	1							
26	1	26013-080202	BOLT, M8X 20	8							
27	1	10530H-21700	V-PULLEY	1							1

Remarks

(1)P.T.O. specification(Optional parts).

N:Old $\xrightarrow{\text{Yes}}$ New, Q:Old $\xrightarrow{\text{No}}$ New, R:Old $\xrightarrow{\text{Yes}}$ New, S:Old $\xrightarrow{\text{No}}$ New, W:Add, Z:Discontinued, F:Interchangeable by set, K:Q'ty Change

Fig.8. PISTON & CONNECTING ROD

(A)=TF160LE
(B)=
(C)=

(D)=
(E)=
(F)=

No.	Lev.	Parts No.	Description	Q'ty						I	R
				(A)	(B)	(C)	(D)	(E)	(F)		
1	1	105800-22090	PISTON ASSY	1							
3	2	704800-22502	RING SET, PISTON	1							
8	1	121850-22300	PIN, PISTON	1							
9	1	101400-22400	CIRCLIP	2							
10	1	105700-23011	ROD ASSY, CONNECTING	1							
12	2	121850-23200	BOLT, CONNECTING ROD	2							
14	1	10570H-23300	METAL, CRANK PIN	2							
15	1	105800-22470	PISTON ASSY, 0.25 OS	1							1
17	2	105800-22510	RING SET, 0.25 OS	1							1
22	1	105800-22480	PISTON ASSY, 0.50 OS	1							2
24	2	105800-22520	RING SET, 0.50 OS	1							2
29	1	105700-23910	BEARING, PISTON PIN	1							3
30	1	10570H-23350	METAL, CRANK PIN	2							4
31	1	10570H-23360	METAL, CRANK PIN	2							5

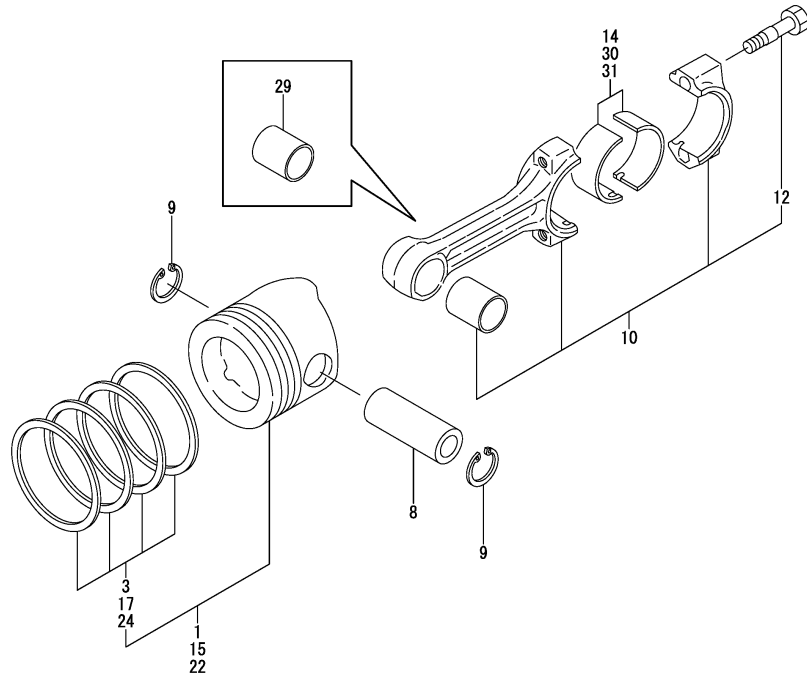

Remarks

- (1) Over-sized (O.S.=0.25) parts.
- (2) Over-sized (O.S.=0.5) parts.
- (3) Spare parts.
- (4) Under-sized (U.S.=0.25) parts.
- (5) Under-sized (U.S.=0.5) parts.

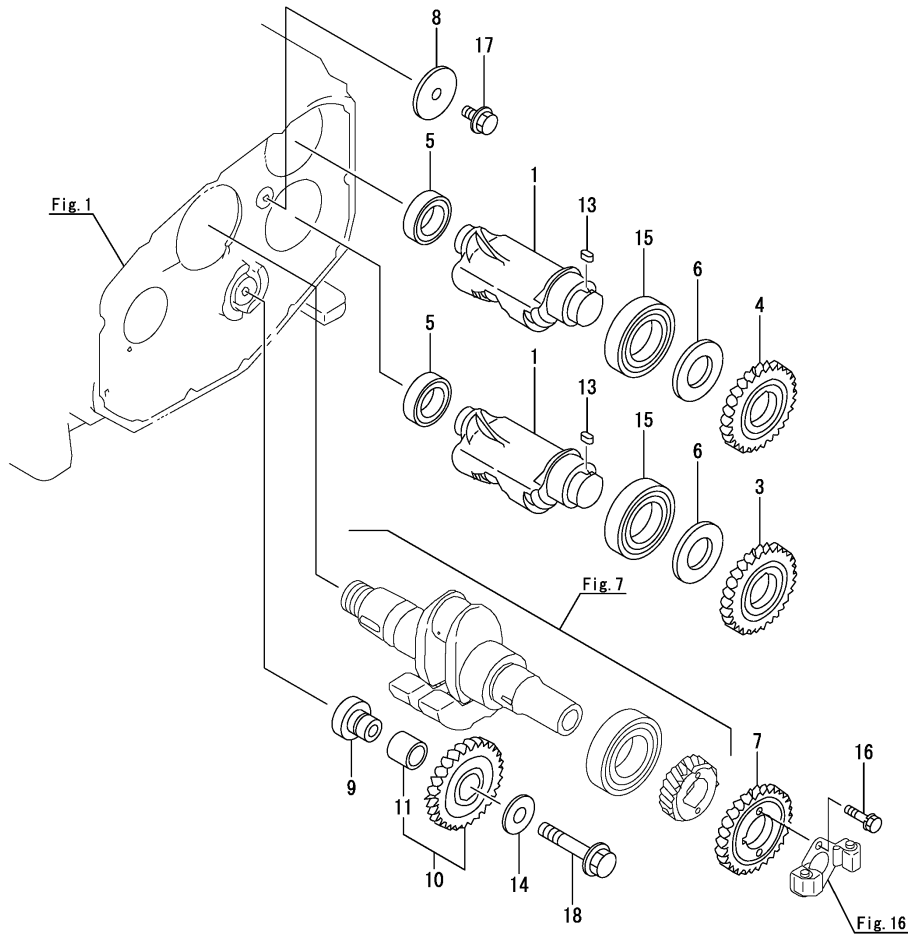

(A)=TF160LE
 (B)=
 (C)=

(D)=
 (E)=
 (F)=

No.	Lev.	Parts No.	Description	Q'ty						I	R
				(A)	(B)	(C)	(D)	(E)	(F)		
1	1	105700-28251	SHAFT, BALANCER	2							
3	1	105700-28300	GEAR, BALANCER	1							
4	1	105700-28310	GEAR, BALANCER	1							
5	1	105700-28360	BEARING, 6205SH2	2							
6	1	105500-28380	SPACER	2							
7	1	105700-28410	GEAR, BALANCER	1							
8	1	105700-28451	RETAINER	1							
9	1	105300-28700	SHAFT	1							
10	1	105700-28710	GEAR ASSY, IDLE	1							
11	2	105430-28720	BUSH, IDLE GEAR	1							
13	1	105215-76490	KEY	2							
14	1	123672-83880	RETAINER	1							
15	1	24101-060104	BEARING, BALL 6010	2							
16	1	26013-060222	BOLT, M6X 22	2							
17	1	26106-080142	BOLT, M8X 14 PLATED	1							
18	1	26106-100552	BOLT, M10X 55 PLATED	1							

Fig.10. LUB. OIL SYSTEM

(A)=TF160LE
(B)=
(C)=

(D)=
(E)=
(F)=

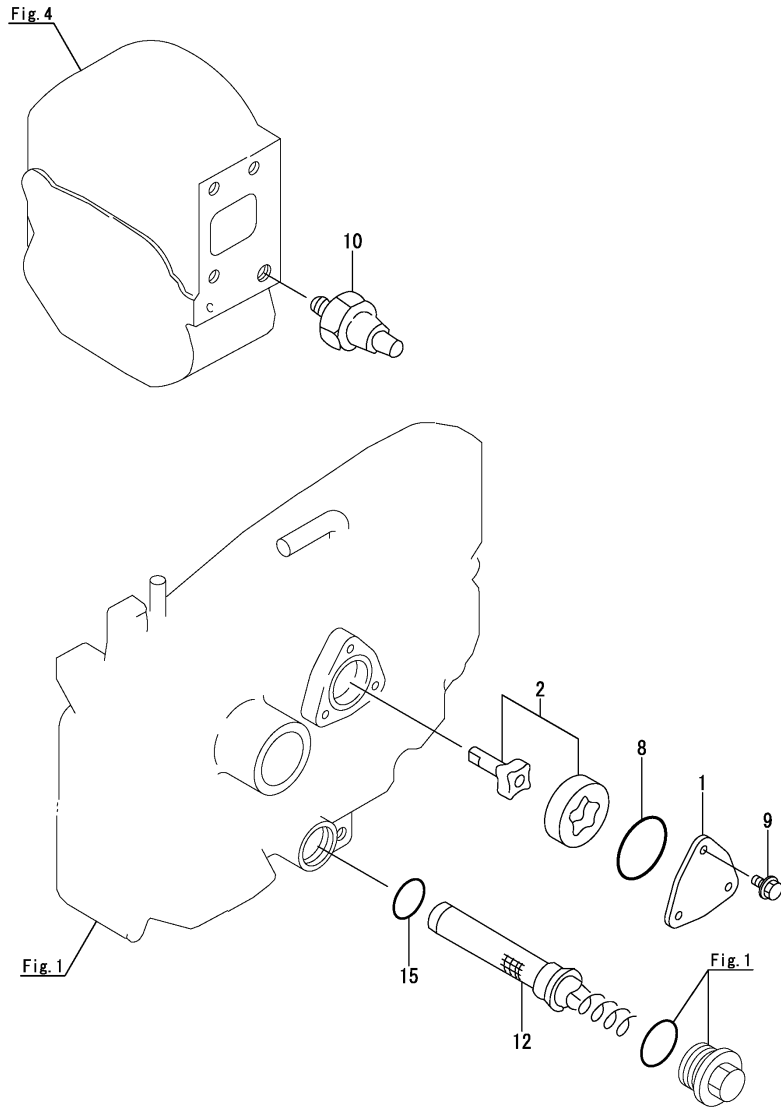

No.	Lev.	Parts No.	Description	Q'ty						I	R
				(A)	(B)	(C)	(D)	(E)	(F)		
1	1	103338-32070	COVER	1							
2	1	105500-32500	PUMP, LUB.OIL CMP	1							
8	1	103338-32570	O-RING	1							
9	1	26106-060122	BOLT, M6X 12 PLATED	3							
10	1	105582-34100	SIGNAL	1							
12	1	105700-35052	STRAINER ASSY, OIL	1							
15	1	24341-000200	O-RING, 1AS20.0	1							

Fig.11. RADIATOR

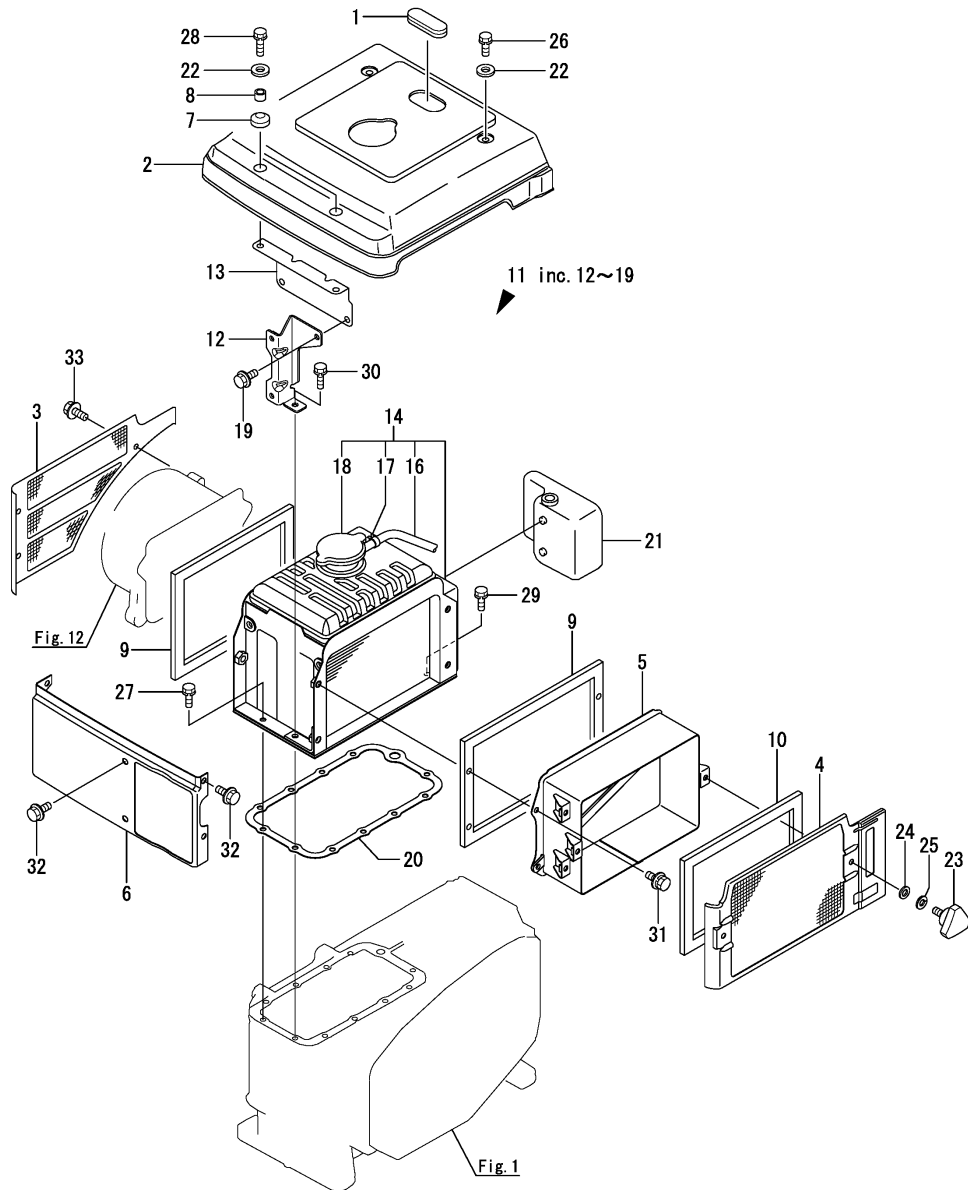

(A)=TF160LE
(B)=
(C)=

(D)=
(E)=
(F)=

No.	Lev.	Parts No.	Description	Q'ty						I	R
				(A)	(B)	(C)	(D)	(E)	(F)		
1	1	105300-44220	COVER, RADIATOR	1							
2	1	105700-44250	COVER, RADIATOR	1							
3	1	105700-44330	SCREEN	1							
4	1	10570H-44340	SCREEN	1							
5	1	10570H-44360	DUCT, SCREEN	1							
6	1	10570H-44370	COVER	1							
7	1	105300-44451	ABSORBER	2							
8	1	105300-44460	COLLAR	2							
9	1	104607-44540	SPONGE	2							
10	1	106100-44560	SPONGE, 15X5X1000	1							
11	1	10570H-44600	RADIATOR ASSY, SUB	1							
12	2	10570H-44380	STAY	1							
13	2	10570H-44490	STAY, RADIATOR COVER	1							
14	2	10570H-44500	RADIATOR ASSY	1							
16	3	105640-44570	PIPE, 7X225	1							
17	3	121250-44590	CLAMP, HOSE	1							
18	3	10530H-44600	CAP, RADIATOR	1							
19	2	26106-060122	BOLT, M6X 12 PLATED	2							
20	1	10570H-44610	GASKET, RADIATOR	1							
21	1	10570H-44630	TANK, SUB	1							
22	1	10540H-76940	WASHER	4							
23	1	160725-78350	KNOB, BOLT M6X15	2							
24	1	22117-060000	WASHER, 6	2							
25	1	22217-060000	WASHER, SPRING 6	2							
26	1	26013-060142	BOLT, M6X 14	2							
27	1	26013-060162	BOLT, M6X 16	9							
28	1	26013-060182	BOLT, M6X 18	2							
29	1	26013-060182	BOLT, M6X 18	1							
30	1	26013-060202	BOLT, M6X 20	1							
31	1	26014-060142	BOLT, M6X 14	4							
32	1	26106-060122	BOLT, M6X 12 PLATED	6							
33	1	26106-060122	BOLT, M6X 12 PLATED	3							

Fig.12. FAN

(A)=TF160LE
(B)=
(C)=

(D)=
(E)=
(F)=

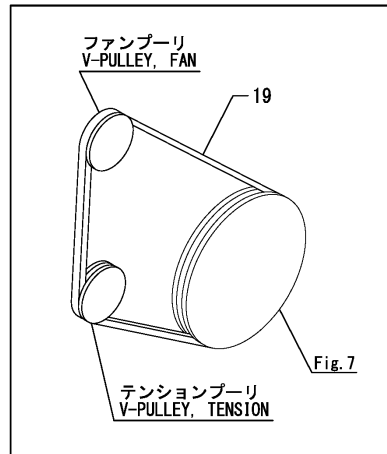
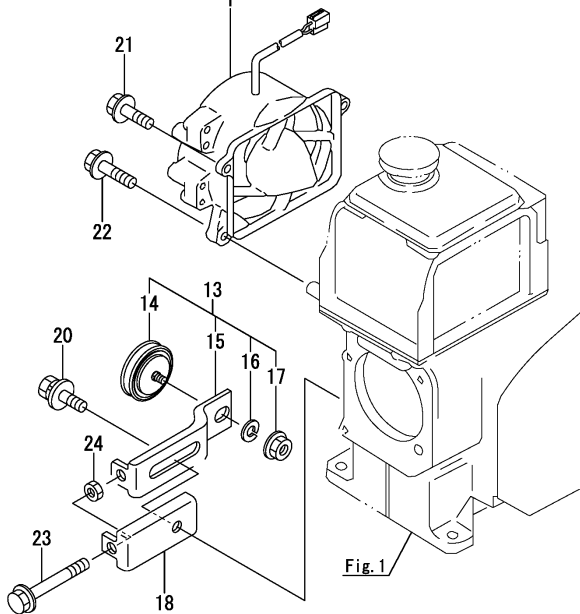
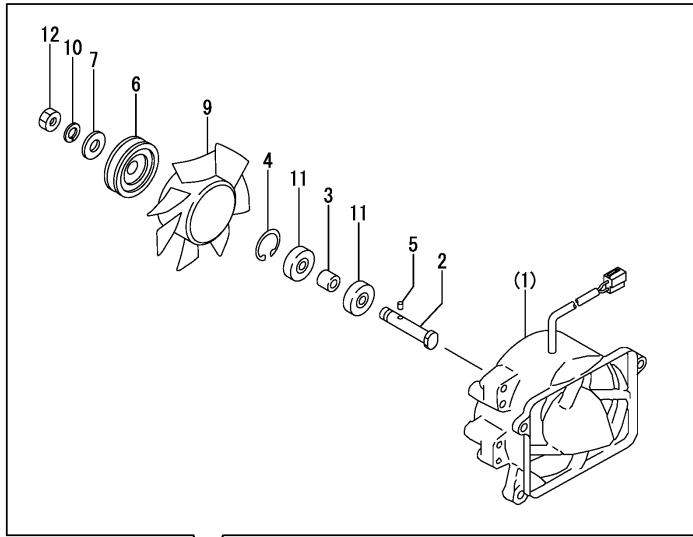

No.	Lev.	Parts No.	Description	Q'ty						I	R
				(A)	(B)	(C)	(D)	(E)	(F)		
1	1	105700-44211	CASE ASSY, FAN	1							
2	2	105340-44710	SHAFT, FAN	1							
3	2	106383-44720	SPACER	1							
4	2	106383-44740	CIRCLIP	1							
5	2	105340-44750	PIN	1							
6	2	105100-44770	PULLEY, FAN	2							
7	2	105100-44780	WASHER, PULLEY	1							
9	2	105700-44850	FAN, COOLING	1							
10	2	22217-120000	WASHER, SPRING 12	1							
11	2	24107-062013	BEARING, 6201ZZP6	2							
12	2	26777-120002	NUT, LOCK M12	1							
13	1	10570H-44820	PULLEY ASSY, TENSION	1							
14	2	10610H-44651	PULLEY, TENSION	1							
15	2	10570H-44950	LEVER, TENSION PULLEY	1							
16	2	22217-080000	WASHER, SPRING 8	1							
17	2	26366-080002	NUT, M8	1							
18	1	105700-44951	LEVER, PULLEY	1							
19	1	25117-004101	V-BELT, M41H	1							
20	1	26014-080202	BOLT, M8X 20	1							
21	1	26106-080252	BOLT, M8X 25 PLATED	2							
22	1	26106-080302	BOLT, M8X 30 PLATED	2							
23	1	26106-080604	BOLT M 8X 60	1							
24	1	26756-080002	NUT, LOCK M8	1							

Fig.13. FUEL INJECTION PUMP

(A)=TF160LE
(B)=
(C)=

(D)=
(E)=
(F)=

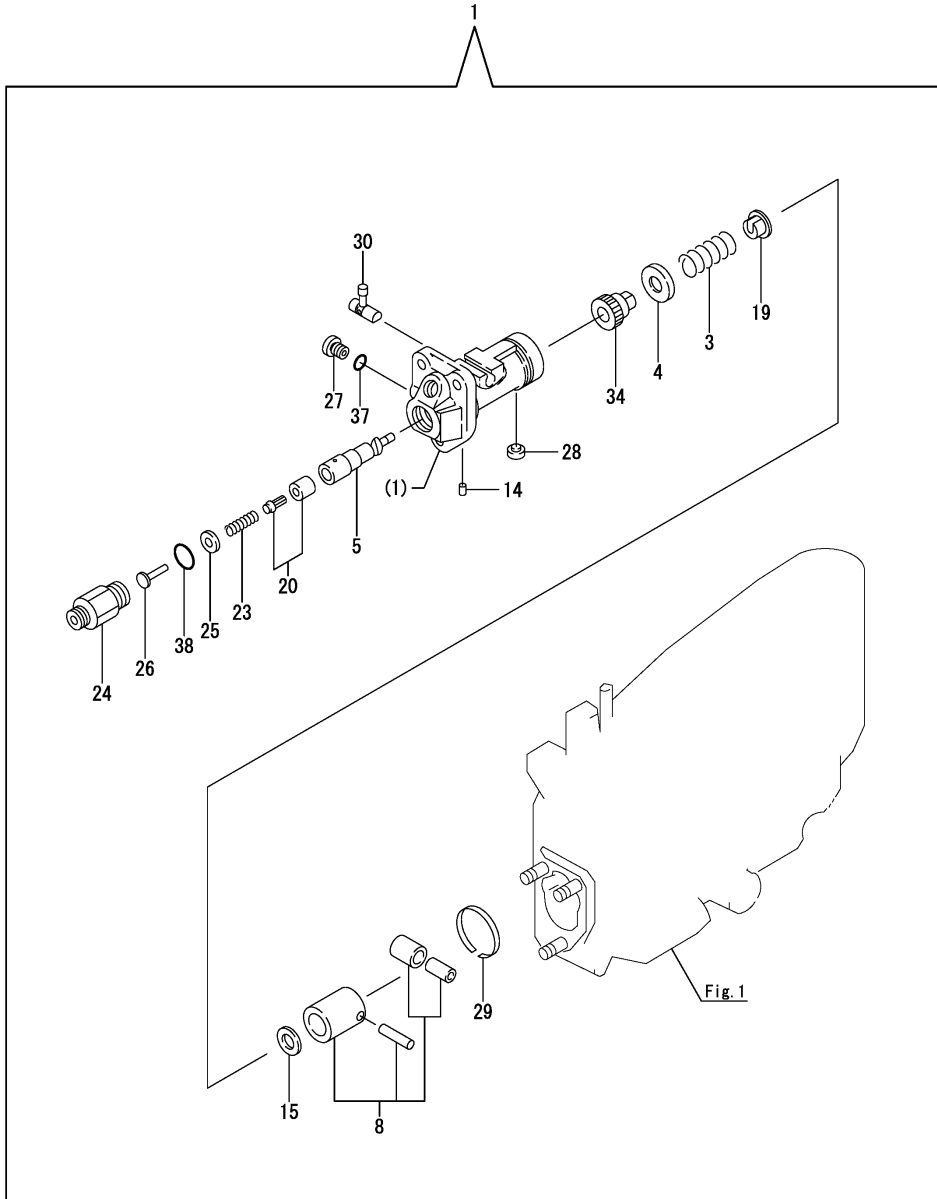

No.	Lev.	Parts No.	Description	Q'ty						I	R
				(A)	(B)	(C)	(D)	(E)	(F)		
1	1	70580H-51100	PUMP ASSY, INJECTION	1							
3	2	105990-51180	SPRING, PLUNGER	1							
4	2	105990-51190	RETAINER, SPRING A	1							
5	2	105700-51200	PLUNGER ASSY	1							
8	2	105990-51200	TAPPET ASSY	1							
14	2	103854-51251	PIN, PLUNGER	1							
15	2	105990-51250	SHIM SET	1							
19	2	105990-51290	RETAINER, SPRING B	1							
20	2	105700-51300	VALVE ASSY, DELIVERY	1							
23	2	121952-51330	SPRING, DELIVERY	1							
24	2	105990-51340	HOLDER	1							
25	2	122710-51350	GASKET	1							
26	2	121952-51370	STOPPER, VALVE	1							
27	2	105990-51400	PLUG, DEFLECTOR	1							
28	2	105990-51450	PIN	1							
29	2	103854-51460	CIRCLIP	1							
30	2	105700-51500	RACK ASSY, CONTROL	1							
34	2	105990-51550	SLEEVE, PINION	1							
37	2	24312-000060	O-RING, 2P6.0	1							
38	2	24312-000210	O-RING 2 P-21.0	1							

Fig.14. FUEL INJECTION DEVICE

(A)=TF160LE

(B)=

(C)=

(D)=

(E)=

(F)=

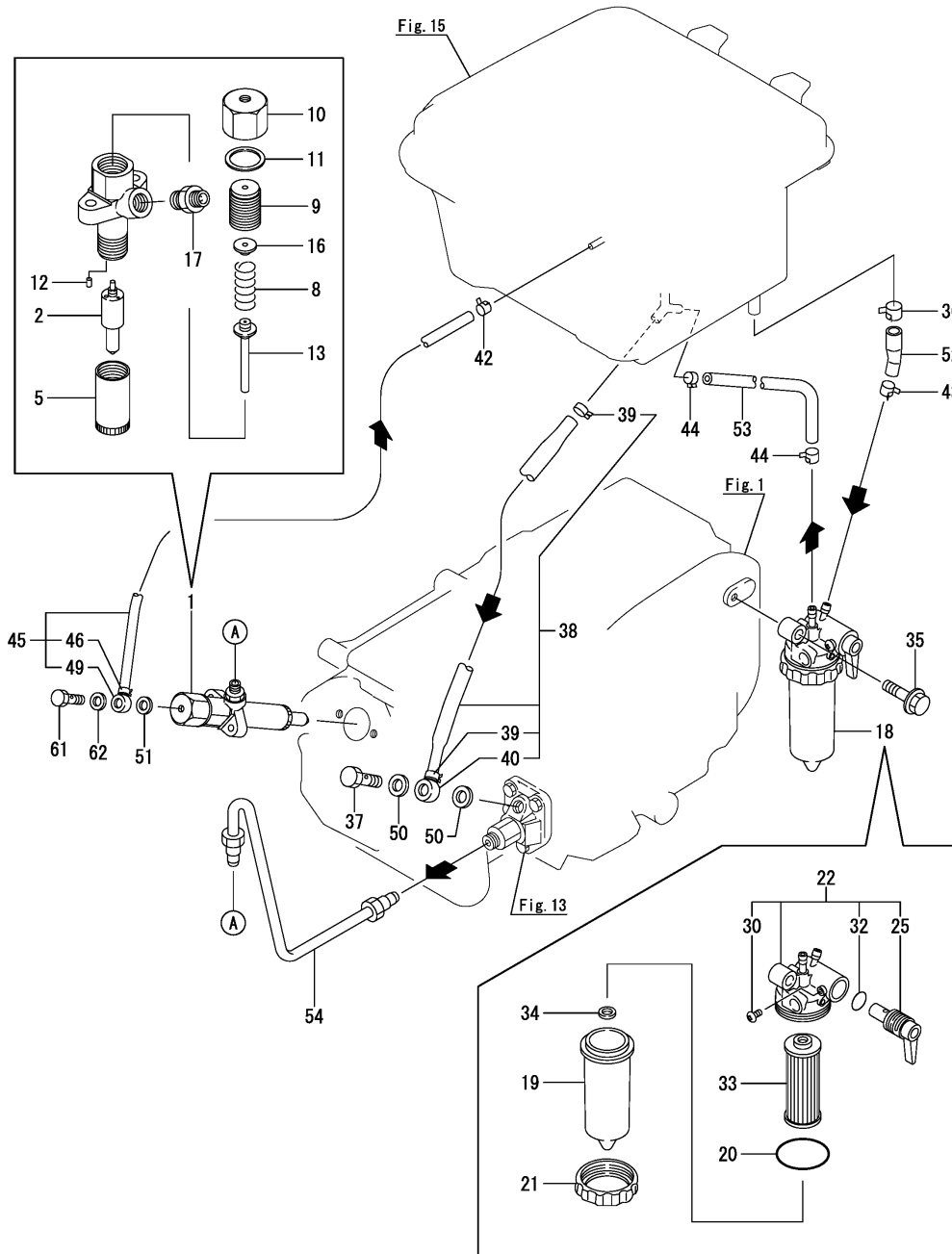

No.	Lev.	Parts No.	Description	Qty						I	R
				(A)	(B)	(C)	(D)	(E)	(F)		
1	1	705700-53100	VALVE ASSY,INJECTION	1							
2	2	105700-53000	VALVE ASSY,INJECTION	1							
5	2	126630-53080	NUT, NOZZLE L=48	1							
8	2	144626-53120	SPRING, NOZZLE	1							
9	2	144626-53181	HOLDER	1							
10	2	126630-53190	CAP, SPRING	1							
11	2	144626-53200	GASKET	1							
12	2	103200-53210	KNOCK, VALVE	2							
13	2	121850-53250	SPINDLE ASSY	1							
16	2	144626-53301	RETAINER, SPRING	1							
17	2	127610-53330	JOINT	1							
18	1	105198-55600	STRAINER ASSY, FUEL	1							
19	2	105198-55510	CUP, STRAINER	1							
20	2	105300-55520	O-RING	1							
21	2	105300-55610	RING, RETAINING	1							
22	2	105300-55700	BODY ASSY, STRAINER	1							
25	3	105300-55340	LEVER	1							
30	3	104200-55750	SCREW, PAN M4	1							
32	3	24311-000160	O-RING, 1AP16.0	1							
33	2	105370-55711	ELEMENT	1							
34	2	105300-55750	FLOAT	1							
35	1	26106-080302	BOLT, M8X 30 PLATED	1							
36	1	129301-03660	CLAMP 15	1							
37	1	103854-39140	BOLT, PIPE JOINT	1							
38	1	105700-59020	PIPE ASSY, FUEL	1							
39	2	129301-03660	CLAMP 15	2							
40	2	105800-59270	JOINT, PIPE 12	1							
42	1	124722-59050	CLAMP, HOSE 9	1							
43	1	124766-59050	CLAMP, HOSE 11.5	1							
44	1	124766-59050	CLAMP, HOSE 11.5	2							
45	1	105840-59140	PIPE ASSY, RETURN	1							
46	2	124722-59050	CLAMP, HOSE 9	1							
49	2	103854-59110	JOINT	1							
50	1	104200-59170	GASKET, 12	2							
51	1	104884-59170	GASKET	1							
52	1	105700-59561	PIPE, FUEL	1							
53	1	105700-59570	PIPE, FUEL	1							
54	1	105700-59800	PIPE ASSY, INJECTION	1							
61	1	101147-59810	BOLT, PIPE JOINT M8	1							
62	1	23414-080012	GASKET, 8X1.0	1							

Fig.15. FUEL TANK

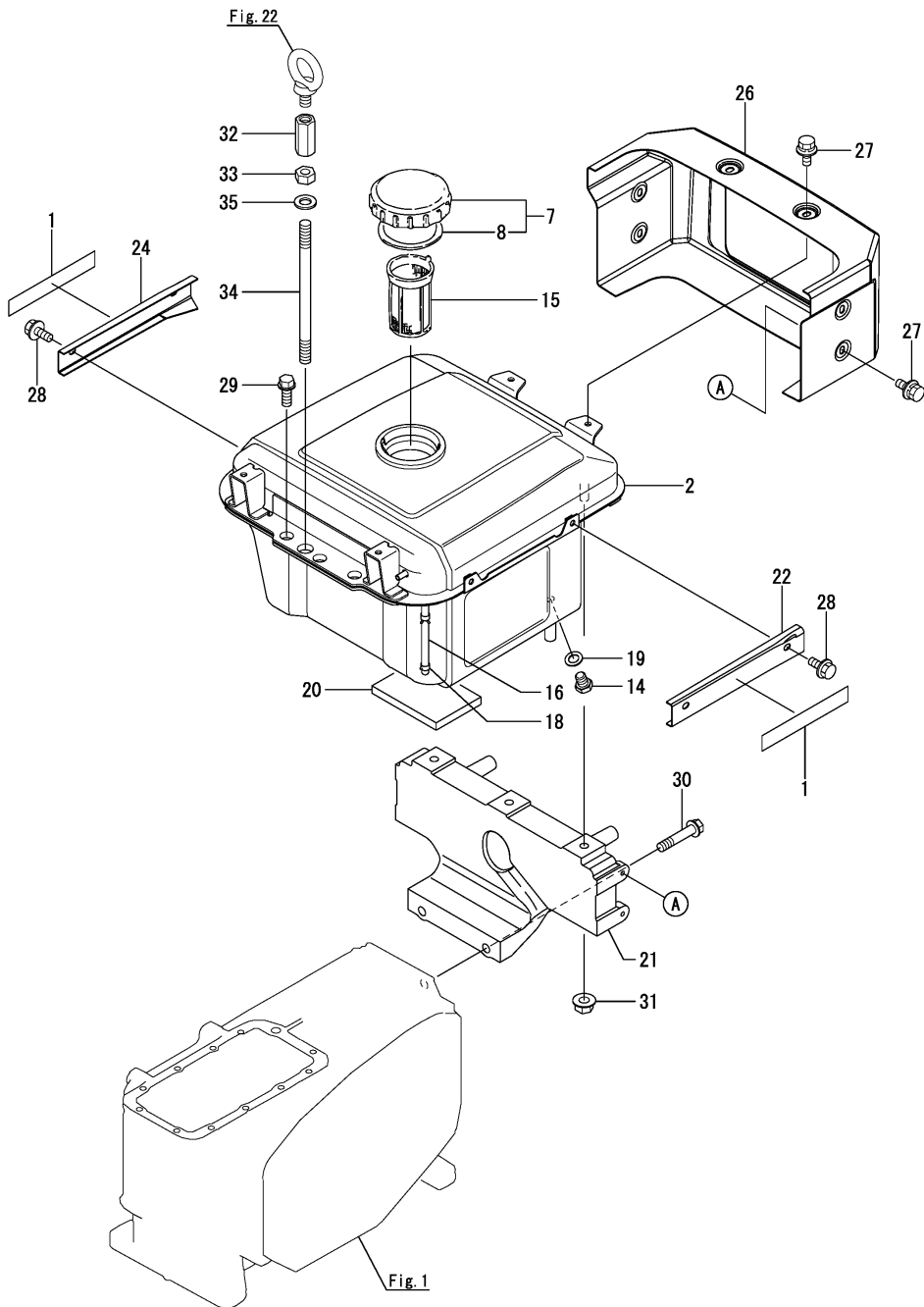

(A)=TF160LE
(B)=
(C)=

(D)=
(E)=
(F)=

No.	Lev.	Parts No.	Description	Q'ty						I	R
				(A)	(B)	(C)	(D)	(E)	(F)		
1	1	10580H-07100	LABEL, ENGINE MODEL	2							
2	1	10570H-55010	TANK ASSY, FUEL OIL	1							
7	1	10547H-55040	CAP, FUEL TANK	1							
8	2	10530H-55050	GASKET	1							
14	1	105300-55080	PLUG, 8	1							
15	1	101504-55101	STRAINER, FUEL	1							
16	1	104300-55160	GAUGE, LEVEL	1							
18	1	103854-55220	RETAINER	2							
19	1	23414-080000	GASKET, 8X1.0	1							
20	1	10570H-55210	SEAT, FELT	2							
21	1	10570H-55240	STAY	1							
22	1	10580H-55240	GUARD, LINE OFW	1							
24	1	10580H-55290	GUARD, LINE FW	1							
26	1	10570H-55810	COVER, LIGHT	1							
27	1	26014-060142	BOLT, M6X 14	6							
28	1	26106-060102	BOLT, M6X 10 PLATED	4							
29	1	26106-100202	BOLT, M10X 20 PLATED	2							
30	1	26106-100502	BOLT, M10X 50 PLATED	2							
31	1	26366-080002	NUT, M8	3							
32	1	105700-07910	NUT	1							
33	1	104507-07920	NUT, M12	1							
34	1	10550H-07940	BOLT, ENGINE LIFT	1							
35	1	22137-120000	WASHER, 12	1							

Fig.16. GOVERNOR & CONTROL EQUIPMENT

(A)=TF160LE

(B)=

(C)=

(D)=

(E)=

(F)=

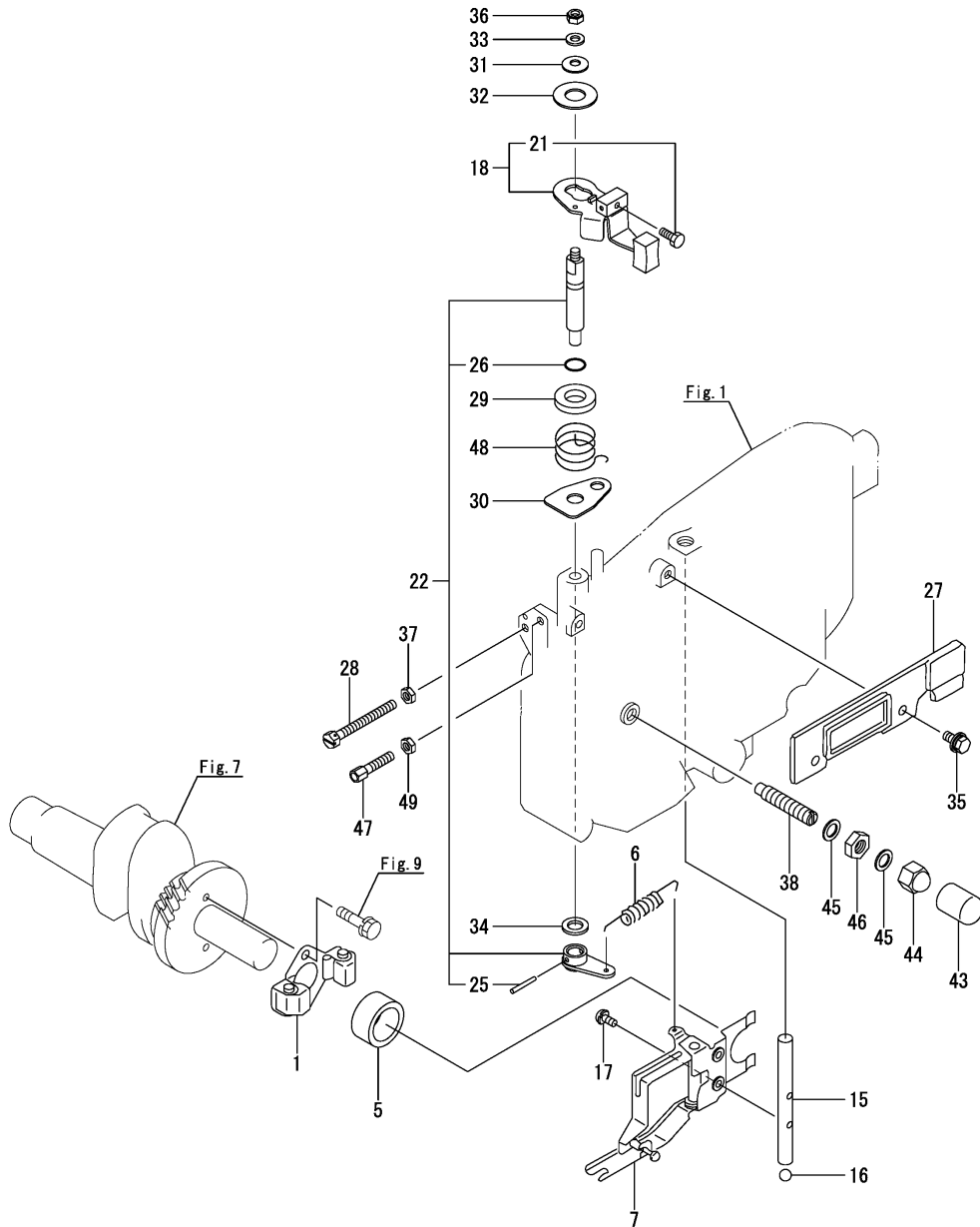

No.	Lev.	Parts No.	Description	Qty						I	R
				(A)	(B)	(C)	(D)	(E)	(F)		
1	1	705300-61701	GOVERNOR ASSY	1							
5	1	10530H-61600	SLEEVE, GOVERNOR	1							
6	1	10570H-66010	SPRING, REGULATOR	1							
7	1	10570H-66310	LEVER ASSY, GOVERNOR	1							
15	1	105300-66400	SHAFT	1							
16	1	24190-120001	BALL, STEEL 3/8	1							
17	1	26022-050102	SCREW, M5X10	2							
18	1	10570H-66041	HANDLE ASSY, DECOMP.	1							
21	2	105225-66990	SCREW, M5X8.5	1							
22	1	705215-66700	LEVER ASSY,REGULATOR	1							
25	2	22322-030220	PIN, TAPER 3X22	1							
26	2	24311-000100	O-RING, 1AP10.0	1							
27	1	10570H-66110	COVER, HANDLE	1							
28	1	105300-66520	SCREW	1							
29	1	10570H-66830	PLATE, FRICTION	1							
30	1	10570H-66850	RETAINER	1							
31	1	10540H-66880	SPRING	1							
32	1	104600-76461	PIECE, DISTANCE	1							
33	1	22137-060000	WASHER, 6	1							
34	1	22137-100000	WASHER, 10	1							
35	1	26014-060142	BOLT, M6X 14	2							
36	1	26347-060002	NUT, M6	1							
37	1	26756-060002	NUT, LOCK M6	1							
38	1	105500-66551	LIMITER ASSY, FUEL	1							
43	1	10530H-66610	CAP (F.O. LIMITER	1							
44	1	124060-66950	NUT, CAP M10	1							
45	1	22190-100002	WASHER, SEAL 10	2							
46	1	26796-100002	NUT, LOCK M10	1							
47	1	102100-67080	BOLT, ADJUST	1							
48	1	105502-67301	SPRING, RETURN	1							
49	1	26756-060002	NUT, LOCK M6	1							

Fig.17. STARTING DEVICE

(A)=TF160LE
(B)=
(C)=

(D)=
(E)=
(F)=

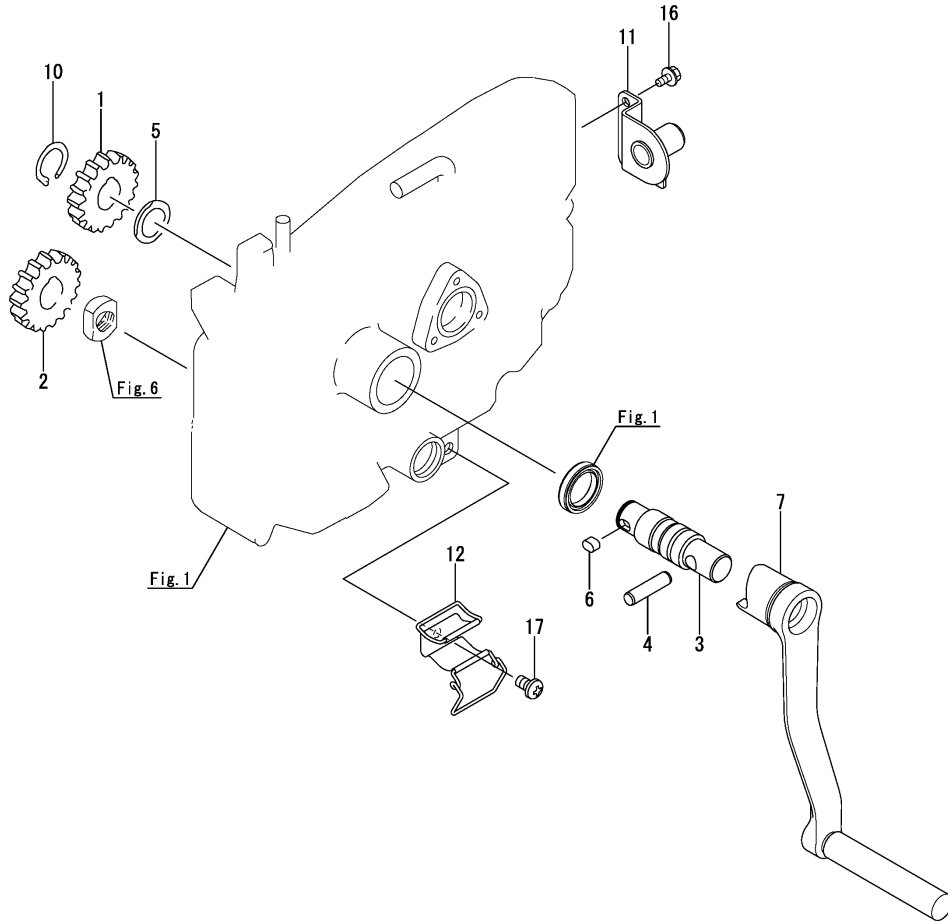

No.	Lev.	Parts No.	Description	Q'ty						I	R
				(A)	(B)	(C)	(D)	(E)	(F)		
1	1	10530G-76330	GEAR, STARTING	1							
2	1	10530G-76330	GEAR, STARTING	1							
3	1	10570H-76340	SHAFT, STARTING	1							
4	1	10570H-76480	PIN, STARTING SHAFT	1							
5	1	105300-76470	COLLAR	1							
6	1	105300-76490	KEY, 7X10	1							
7	1	10570H-76790	HANDLE ASSY, START	1							
10	1	22242-000200	RING, 20	1							
11	1	10570H-08101	RETAINER, HANDLE	1							
12	1	10530G-08510	SPRING ASSY	1							
16	1	26106-060122	BOLT, M6X 12 PLATED	2							
17	1	26557-060102	SCREW, M6X10	1							

Fig.18. STARTER MOTOR

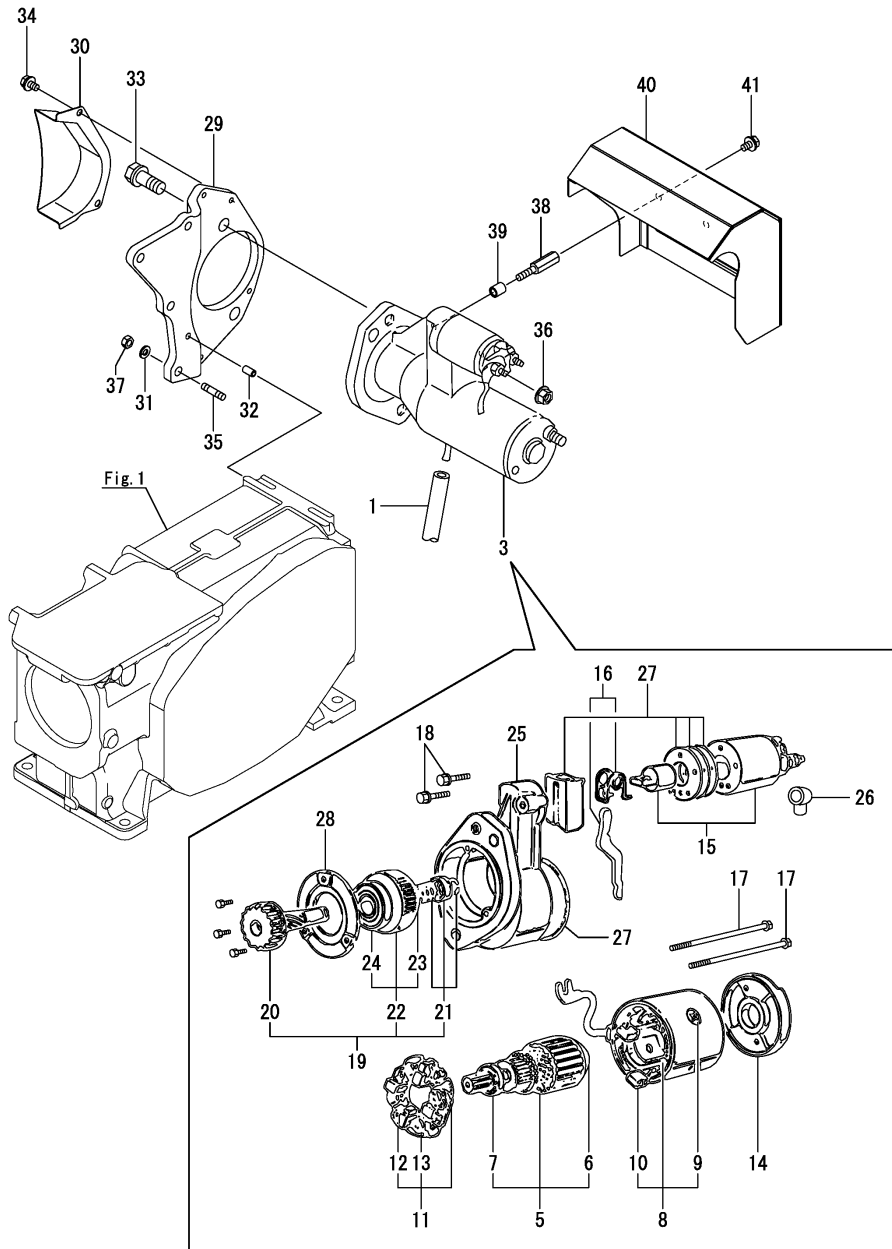

(A)=TF160LE
(B)=
(C)=

(D)=
(E)=
(F)=

No.	Lev.	Parts No.	Description	Qty						I	R
				(A)	(B)	(C)	(D)	(E)	(F)		
1	1	105840-59100	PIPE	1							
3	1	10530H-77030	MOTOR, STARTER ADD	1							
5	3	X211461005	ARMATURE	1							
6	4	X2130350900	BEARING, BALL	1							
7	4	X211425511	BALL BEARING	1							
8	3	X211442003	COIL ASSY, FIELD	1							
9	4	X21143215	SCREW, CORE	4							
10	4	X211469002	BRUSH (+)	2							
11	3	X211449007	HOLDER ASSY, BRUSH	1							
12	4	X211459002	BRUSH (-)	2							
13	4	X21148314	SPRING, BRUSH	4							
14	3	X211483003	COVER	1							
15	3	X2114T71110	SWITCH, MAGNETIC	1							
16	3	X211446012	LEVER, SHIFT	1							
17	3	X211468005	BOLT, THROUGH	2							
18	3	X21145866	BOLT	2							
19	3	X211455011	PINION ASSY	1							
20	4	X211465011	SHAFT, PINION	1							
21	4	X211429006	STOPPER SET	1							
22	4	X211425506	CLUTCH ASSY	1							
23	5	X211495502	BEARING, BALL	1							
24	5	X211455502	BALL BEARING	1							
25	3	X211456605	CASE ASSY, GEAR	1							
26	3	X21142742	COVER (A), RUBBER	1							
27	3	X211458012	COVER KIT	1							
28	3	X211428008	RETAINER, BEARING	1							
29	1	10580H-77470	BRACKET, STARTER	1							
30	1	10567H-77480	COVER, PINION	1							
31	1	22217-060000	WASHER, SPRING 6	4							
32	1	22351-060012	PIN, SPRING 6.0X12	1							
33	1	26013-120302	BOLT, M12X 30	2							
34	1	26014-060122	BOLT, M6X 12	2							
35	1	26216-060202	STUD, M6X 20	4							
36	1	26366-080002	NUT, M8	1							
37	1	26716-060002	NUT, M6	4							
38	1	10540H-77500	BOLT, SPACER	2							
39	1	10567H-77600	COLLAR	2							
40	1	10567H-77780	COVER, STARTER MOTOR	1							
41	1	26014-060122	BOLT, M6X 12	2							

Fig.19. LAMP

(A)=TF160LE
(B)=
(C)=

(D)=
(E)=
(F)=

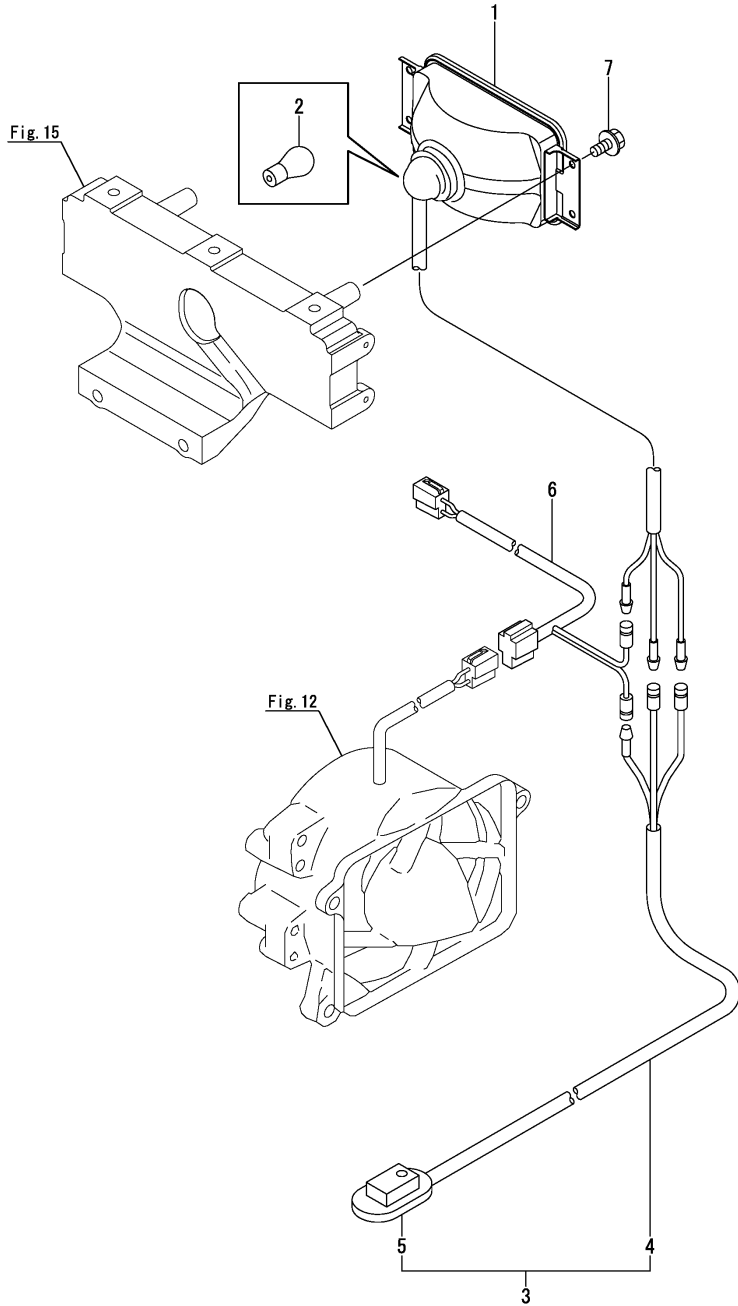

No.	Lev.	Parts No.	Description	Q'ty						I	R
				(A)	(B)	(C)	(D)	(E)	(F)		
1	1	10570H-78020	LAMP ASSY	1							
2	2	10530H-78250	BULB, 45W	1							
3	1	10530H-78520	SWITCH ASSY, RIGHT	1							
4	2	10530H-78530	HARNES, WIRE	1							
5	2	10530H-78960	SWITCH, LIGHT	1							
6	1	10567H-78600	HARNES, WIRE E	1							
7	1	26014-060142	BOLT, M6X 14	4							

Fig.20. LABEL

(A)=TF160LE
(B)=
(C)=

(D)=
(E)=
(F)=

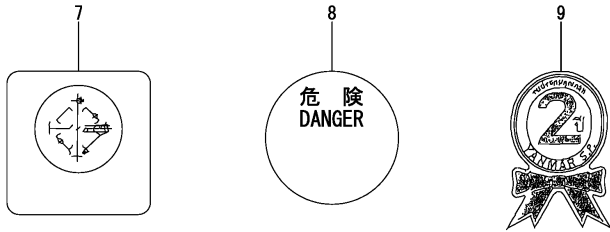
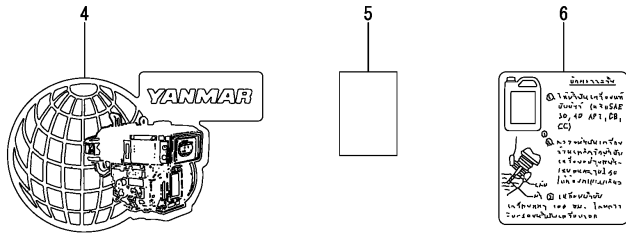
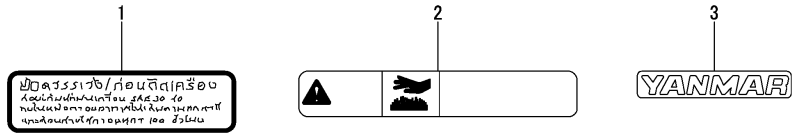

No.	Lev.	Parts No.	Description	Q'ty						I	R
				(A)	(B)	(C)	(D)	(E)	(F)		
1	1	10530H-07211	LABEL, AIR CLEANER	1							
2	1	10537H-07330	LABEL, CAUTION	1							
3	1	10530H-07530	LABEL, YANMAR	1							
4	1	10540H-07621	LABEL, YANMAR WORLD	1							
5	1	10540H-07640	LABEL, F.O.STRAINER	1							
6	1	10530H-07670	LABEL, CAUTION	1							
7	1	10530H-07720	LABEL, TIS MARK	1							
8	1	10530H-07750	LABEL, RADIATOR	1							
9	1	10530H-07781	LABEL, WARRANTY 2	1							
10	1	10530H-07700	LABEL, CAUTION	1							1

Remarks

(1)Optional parts.

N:Old $\xrightarrow{\text{Yes}}$ New, Q:Old $\xrightarrow{\text{No}}$ New, R:Old $\xrightarrow{\text{Yes}}$ New, S:Old $\xrightarrow{\text{No}}$ New, W:Add, Z:Discontinued, F:Interchangeable by set, K:Q'ty Change

Parts No. Index

Parts No.	Fig. No.	Ref. No.
101104-01760	1	30
101147-59810	14	61
101158-03111	2	4
101400-22400	8	9
101504-55101	15	15
102100-67080	16	47
103200-53210	14	12
103338-32070	10	1
103338-32570	10	8
103854-01200	1	9
103854-01221	1	10
103854-11180	4	10
103854-11191	4	11
103854-11230	4	18
		22
103854-14200	6	6
103854-39140	14	37
103854-51251	13	14
103854-51460	13	29
103854-55220	15	18
103854-59110	14	49
104104-03750	4	37
104200-03641	4	39
104200-55750	14	30
104200-59170	14	50
104200-92350	21	2
104300-55160	15	16
104300-76460	6	10
104507-07920	15	33
104600-21130	7	6
104600-76461	16	32
104607-44540	11	9
104700-01240	1	11
104700-02220	7	19
104884-59170	14	51
105010-11920	4	26
105100-01660	1	19
105100-44770	12	6
105100-44780	12	7
10510H-21600	7	15
105198-55510	14	19
105198-55600	14	18
105215-76490	9	13
105225-66990	16	21
105300-01690	1	28
105300-11330	4	6
105300-28700	9	9
105300-34040	1	21
105300-44220	11	1
105300-44451	11	7

Parts No.	Fig. No.	Ref. No.
105300-44460	11	8
105300-55080	15	14
105300-55340	14	25
105300-55520	14	20
105300-55610	14	21
105300-55700	14	22
105300-55750	14	34
105300-66400	16	15
105300-66520	16	28
105300-76470	17	5
105300-76490	17	6
10530G-08510	17	12
10530G-76330	17	1
		2
10530G-92600	21	3
10530H-03550	4	35
10530H-03610	4	36
10530H-07211	20	1
10530H-07530	20	3
10530H-07670	20	6
10530H-07700	20	10
10530H-07720	20	7
10530H-07750	20	8
10530H-07781	20	9
10530H-21700	7	27
10530H-44600	11	18
10530H-55050	15	8
10530H-61600	16	5
10530H-66610	16	43
10530H-77030	18	3
10530H-78250	19	2
10530H-78520	19	3
10530H-78530	19	4
10530H-78960	19	5
10530H-92100	21	1
105340-44710	12	2
105340-44750	12	5
105362-78960	2	5
105370-55711	14	33
10537H-03060	2	2
10537H-07330	20	2
10537H-14190	6	5
10537H-97132	22	4
10540H-07621	20	4
10540H-07640	20	5
10540H-66880	16	31
10540H-76940	11	22
10540H-77500	18	38
10540H-92701	22	2
105430-28720	9	11

Parts No.	Fig. No.	Ref. No.
10547H-55040	15	7
10547H-95701	22	3
105500-28380	9	6
105500-32500	10	2
105500-66551	16	38
105502-67301	16	48
10550H-01481	1	26
10550H-01490	1	27
10550H-07940	15	34
10550H-21530	7	10
10557H-21520	7	8
105582-34100	10	10
105640-44570	11	16
10567H-77480	18	30
10567H-77600	18	39
10567H-77780	18	40
10567H-78600	19	6
105700-01300	1	8
105700-01410	1	25
105700-02020	7	22
105700-02320	7	20
105700-03132	2	7
105700-07910	15	32
105700-08010	3	1
105700-08020	3	2
105700-08050	3	3
105700-11100	4	7
105700-11111	4	8
105700-11290	4	13
105700-11801	4	46
105700-12050	5	2
105700-13201	5	13
105700-14010	6	1
105700-14090	6	3
105700-14100	6	4
105700-14600	6	8
105700-21010	7	1
105700-21200	7	9
105700-21591	7	11
105700-21601	7	14
105700-23011	8	10
105700-23910	8	29
105700-28251	9	1
105700-28300	9	3
105700-28310	9	4
105700-28360	9	5
105700-28410	9	7
105700-28451	9	8
105700-28710	9	10
105700-35052	10	12

Parts No.	Fig. No.	Ref. No.
105700-44211	12	1
105700-44250	11	2
105700-44330	11	3
105700-44850	12	9
105700-44951	12	18
105700-51200	13	5
105700-51300	13	20
105700-51500	13	30
105700-53000	14	2
105700-59020	14	38
105700-59561	14	52
105700-59570	14	53
105700-59800	14	54
10570G-11650	4	34
10570H-01331	1	12
10570H-01392	1	13
10570H-01750	1	29
10570H-01850	1	31
10570H-02310	7	24
10570H-03070	2	1
10570H-08101	17	11
10570H-11120	4	9
10570H-11310	4	43
10570H-11650	4	16
10570H-11660	4	20
10570H-11910	4	25
10570H-11940	4	27
10570H-12021	5	1
10570H-12510	5	3
10570H-12551	5	10
10570H-12701	5	4
10570H-12710	5	5
10570H-12750	5	6
10570H-12800	5	7
10570H-12850	5	8
10570H-12860	5	9
10570H-13519	5	14
10570H-13570	5	15
10570H-14400	6	7
10570H-14700	6	9
10570H-21100	7	5
10570H-21290	7	7
10570H-23300	8	14
10570H-23350	8	30
10570H-23360	8	31
10570H-44340	11	4
10570H-44360	11	5
10570H-44370	11	6
10570H-44380	11	12
10570H-44490	11	13

Parts No. Index

Parts No.	Fig. No.	Ref. No.
10570H-44500	11	14
10570H-44600	11	11
10570H-44610	11	20
10570H-44630	11	21
10570H-44820	12	13
10570H-44950	12	15
10570H-55010	15	2
10570H-55210	15	20
10570H-55240	15	21
10570H-55810	15	26
10570H-66010	16	6
10570H-66041	16	18
10570H-66110	16	27
10570H-66310	16	7
10570H-66830	16	29
10570H-66850	16	30
10570H-76340	17	3
10570H-76480	17	4
10570H-76790	17	7
10570H-78020	19	1
10570H-92510	22	1
10571H-61250	1	24
105800-02300	7	23
105800-22090	8	1
105800-22470	8	15
105800-22480	8	22
105800-22510	8	17
105800-22520	8	24
105800-59270	14	40
10580H-07100	15	1
10580H-55240	15	22
10580H-55290	15	24
10580H-77470	18	29
105840-59100	18	1
105840-59140	14	45
105990-51180	13	3
105990-51190	13	4
105990-51200	13	8
105990-51250	13	15
105990-51290	13	19
105990-51340	13	24
105990-51400	13	27
105990-51450	13	28
105990-51550	13	34
106100-44560	11	10
10610H-44651	12	14
106383-44720	12	3
106383-44740	12	4
121250-44590	11	17
121850-22300	8	8

Parts No.	Fig. No.	Ref. No.
121850-23200	8	12
121850-53250	14	13
121952-51330	13	23
121952-51370	13	26
122710-51350	13	25
123672-83880	9	14
124060-66950	16	44
124722-59050	14	42
		46
124766-59050	14	43
		44
126630-53080	14	5
126630-53190	14	10
127610-53330	14	17
128610-11900	4	24
129301-03660	14	36
		39
144626-53120	14	8
144626-53181	14	9
144626-53200	14	11
144626-53301	14	16
160725-78350	11	23
22117-060000	11	24
22137-060000	16	33
22137-100000	16	34
22137-120000	15	35
22190-100002	16	45
22217-040000	2	6
22217-060000	11	25
	18	31
22217-080000	5	16
	12	16
22217-100000	4	28
22217-120000	12	10
	22	5
22217-140000	3	4
22242-000200	17	10
22242-000600	7	25
22252-000100	1	22
22312-030180	4	41
22322-030160	4	38
22322-030220	16	25
22351-060012	1	4
		20
	18	32
23064-110450	2	8
23414-080000	15	19
23414-080012	14	62
24101-060064	6	11
24101-060104	9	15

Parts No.	Fig. No.	Ref. No.
24107-062013	12	11
24190-120001	1	23
	16	16
24311-000060	1	45
24311-000070	4	42
24311-000100	16	26
24311-000160	14	32
24312-000060	13	37
24312-000210	13	38
24321-000250	1	46
24341-000200	10	15
25117-004101	12	19
26013-060142	11	26
26013-060162	11	27
26013-060182	11	28
		29
26013-060202	11	30
26013-060222	9	16
26013-080202	7	26
26013-120302	18	33
26014-060122	18	34
		41
26014-060142	11	31
	15	27
	16	35
	19	7
26014-080202	12	20
26022-050102	16	17
26022-060122	6	12
26106-060102	15	28
26106-060122	7	16
	10	9
	11	19
		32
		33
26106-060142	17	16
26106-060142	1	47
26106-060222	2	9
26106-060552	4	44
26106-060702	4	45
26106-080142	9	17
26106-080202	5	11
26106-080252	12	21
26106-080302	12	22
	14	35
26106-080352	1	48
26106-080604	12	23
26106-080752	1	49
26106-100202	15	29
26106-100502	15	30

Parts No.	Fig. No.	Ref. No.
26106-100552	9	18
26116-060102	7	21
26206-120352	22	6
26216-060202	18	35
26216-080222	1	50
	4	29
26216-080502	4	30
26216-100552	4	31
26347-060002	16	36
26366-080002	1	51
	4	32
	5	17
	12	17
	15	31
	18	36
26557-060102	17	17
26557-060202	5	18
26587-080122	6	13
26617-120002	22	7
26636-080002	5	12
26716-060002	18	37
26716-100002	4	33
26716-140002	3	5
26756-060002	16	37
		49
26756-080002	12	24
26777-120002	12	12
26796-100002	4	19
		23
	16	46
28110-100120	21	4
28110-140170	21	5
28110-190220	21	6
704800-22502	8	3
705215-66700	16	22
705300-61701	16	1
705700-01561	1	1
705700-02500	7	17
705700-53100	14	1
705706-11701	4	1
705800-01900	1	5
70580H-51100	13	1
X211425506	18	22
X211425511	18	7
X21142742	18	26
X211428008	18	28
X211429006	18	21
X21143215	18	9
X211442003	18	8
X211446012	18	16

Parts No. Index

Parts No.	Fig. No.	Ref. No.
X211449007	18	11
X211455011	18	19
X211455502	18	24
X211456605	18	25
X211458012	18	27
X21145866	18	18
X211459002	18	12
X211461005	18	5
X211465011	18	20
X211468005	18	17
X211469002	18	10
X211483003	18	14
X21148314	18	13
X211495502	18	23
X2114T71110	18	15
X2130350900	18	6

Parts No.	Fig. No.	Ref. No.
-----------	----------	----------

Parts No.	Fig. No.	Ref. No.
-----------	----------	----------

Parts No.	Fig. No.	Ref. No.
-----------	----------	----------