

0CC50-M00780EN

Introduction

1. This parts catalog is a first edition of the TF160LX diesel engine.

	Date of issue	Remarks
First edition	Mar., 2016	

2. This parts catalog does not contain the technical data needed for maintenance service.

3. The illustrations used in this parts catalog have been simplified for clarity.

4. The contents of this parts catalog are subject to change without notice.

5. Be sure to use only Yanmar genuine parts for repairs. If imitation parts are used, it may cause engine defects.

Contents

OCC50-M00780

Fig. No. Fig. Name

Fig. No. Fig. Name

TF160LX

1. CYLINDER BLOCK
2. BREATHER
3. ENGINE BED
4. CYLINDER HEAD & BONNET
5. AIR CLEANER & MUFFLER
6. CAMSHAFT
7. CRANKSHAFT & FLYWHEEL
8. PISTON & CONNECTING ROD
9. BALANCER
10. LUB. OIL SYSTEM
11. RADIATOR
12. FAN
13. FUEL INJECTION PUMP
14. FUEL INJECTION DEVICE
15. FUEL TANK
16. GOVERNOR & CONTROL EQUIPMENT
17. STARTING DEVICE
18. LAMP
19. LABEL
20. TOOL
21. BUNDLED ITEMS

Fig.1. CYLINDER BLOCK

(A)=TF160LX
(B)=
(C)=

(D)=
(E)=
(F)=

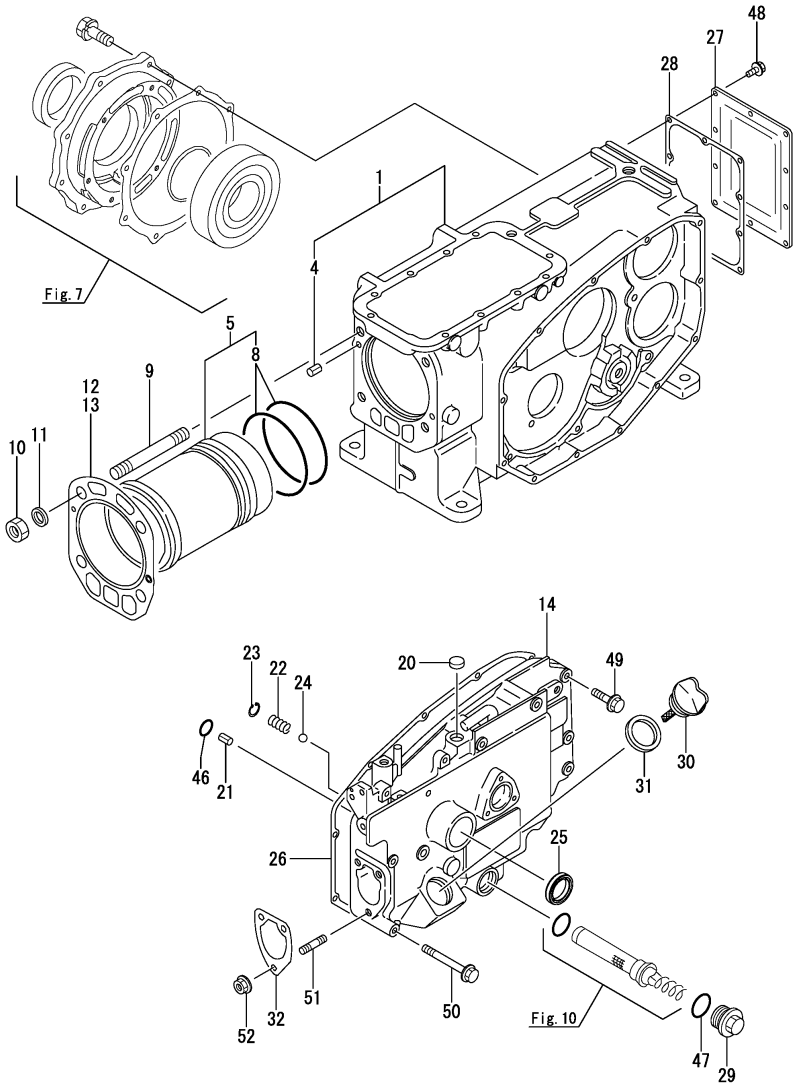

No.	Lev.	Parts No.	Description	Q'ty						I	R
				(A)	(B)	(C)	(D)	(E)	(F)		
1	1	705700-01561	BLOCK ASSY, CYLINDER	1							
4	2	22351-060012	PIN, SPRING 6.0X12	2							
5	1	705800-01900	LINER ASSY, CYLINDER	1							
8	2	105700-01300	O-RING	2							
9	1	103854-01200	BOLT, HEAD	4							
10	1	103854-01221	NUT, CYLINDER HEAD	4							
11	1	104700-01240	WASHER	4							
12	1	10570H-01331	GASKET, HEAD	1							1
13	1	10570H-01340	GASKET, HEAD	1							2
14	1	10570H-01392	CASE ASSY, GEAR	1							
20	1	105100-01660	PLUG, 14	1							
21	1	22351-060012	PIN, SPRING 6.0X12	1							
22	1	105300-34040	SPRING	1							
23	1	22252-000100	RING, 10	1							
24	1	24190-120001	BALL, STEEL 3/8	1							
25	1	10571H-61250	SEAL,OIL START SHAFT	1							
26	1	105700-01410	GASKET, GEAR CASE	1							
27	1	10550H-01481	COVER, REAR	1							
28	1	10550H-01490	GASKET, REAR COVER	1							
29	1	105300-01690	PLUG	1							
30	1	10570H-01750	CAP, DIPSTICK	1							
31	1	101104-01760	GASKET, CAP	1							
32	1	10570H-01850	SHIM ASSY,F.I.TIMING	1							
46	1	24311-000060	O-RING, 1AP6.0	1							
47	1	24321-000250	O-RING, 1AG25.0	1							
48	1	26106-060142	BOLT, M6X 14 PLATED	10							
49	1	26106-080352	BOLT, M8X 35 PLATED	7							
50	1	26106-080752	BOLT, M8X 75 PLATED	6							
51	1	26216-080222	STUD, M8X 22	3							
52	1	26366-080002	NUT, M8	3							

Remarks

- (1) Selective parts(T=1.5mm).
- (2) Selective parts(T=1.4mm).

Fig.2. BREATHER

(A)=TF160LX
(B)=
(C)=

(D)=
(E)=
(F)=

No.	Lev.	Parts No.	Description	Q'ty						I	R
				(A)	(B)	(C)	(D)	(E)	(F)		
1	1	10570H-03070	COVER ASSY, BREATHER	1							
2	2	10537H-03060	VALVE, RETURN	1							
4	2	101158-03111	RETAINER	1							
5	2	105362-78960	SCREW, M4X8	2							
6	2	22217-040000	WASHER, SPRING 4	2							
7	1	105700-03132	GASKET	1							
8	1	23064-110450	HOSE, 11 X 450	1							
9	1	26106-060222	BOLT, M6X 22 PLATED	4							

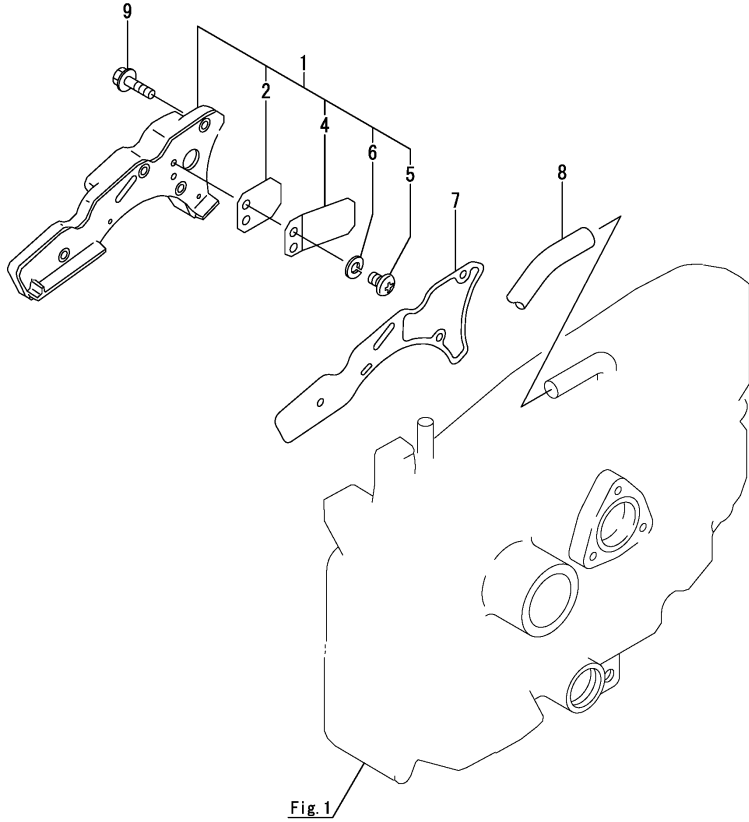
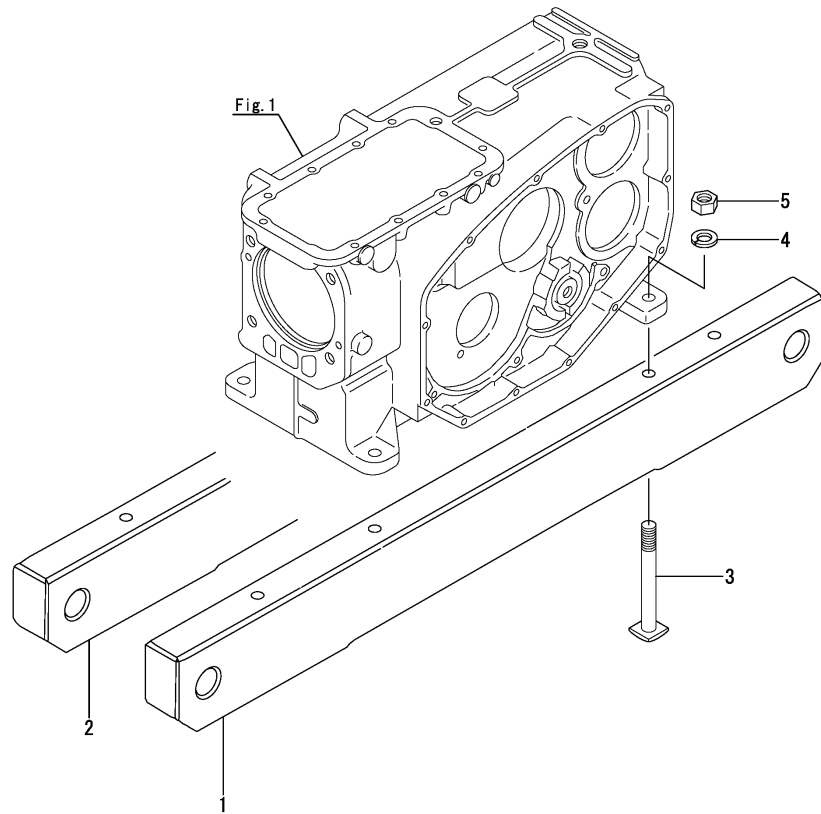

Fig.3. ENGINE BED

(A)=TF160LX
(B)=
(C)=

(D)=
(E)=
(F)=



No.	Lev.	Parts No.	Description	Q'ty						I	R
				(A)	(B)	(C)	(D)	(E)	(F)		
1	1	105700-08010	BED, WOODEN	1							
2	1	105700-08020	BED, WOODEN	1							
3	1	105700-08050	BOLT, FOUNDATION	4							
4	1	22217-140000	WASHER, SPRING 14	4							
5	1	26716-140002	NUT, M14	4							

Fig.4. CYLINDER HEAD & BONNET

(A)=TF160LX

(B)=

(C)=

(D)=

(E)=

(F)=

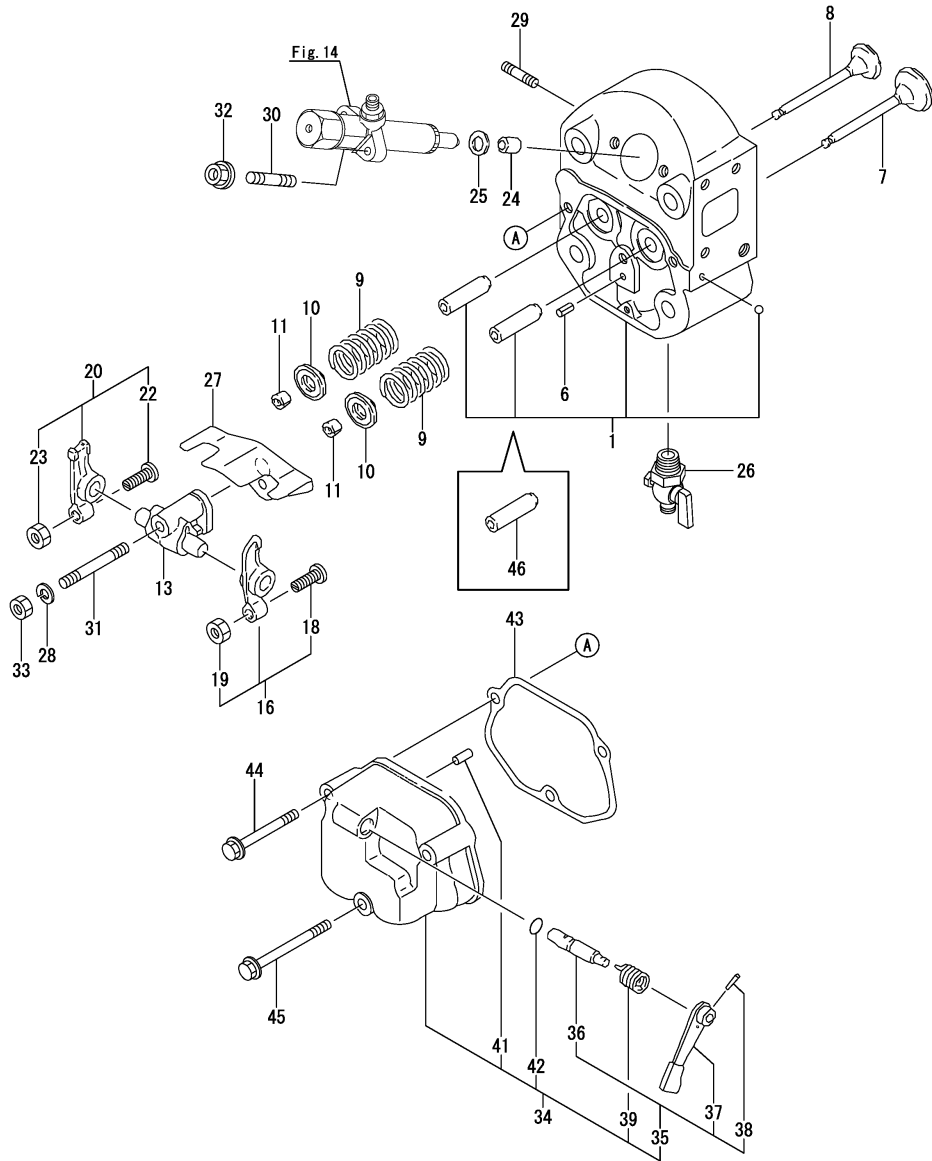

No.	Lev.	Parts No.	Description	Q'ty						I	R
				(A)	(B)	(C)	(D)	(E)	(F)		
1	1	705706-11701	HEAD ASSY, CYLINDER	1							
6	2	105300-11330	PIN	1							
7	1	105700-11100	VALVE, INTAKE	1							
8	1	105700-11111	VALVE, EXHAUST	1							
9	1	10570H-11120	SPRING, VALVE	2							
10	1	103854-11180	RETAINER, SPRING	2							
11	1	103854-11191	COTTER	2							
13	1	105700-11290	SUPPORT ASSY, ARM	1							
16	1	10570H-11650	ARM ASSY, INTAKE	1							
18	2	103854-11230	SCREW, VALVE ADJUST	1							
19	2	26796-100002	NUT, LOCK M10	1							
20	1	10570H-11660	ARM ASSY, EXHAUST	1							
22	2	103854-11230	SCREW, VALVE ADJUST	1							
23	2	26796-100002	NUT, LOCK M10	1							
24	1	128610-11900	INSULATOR	1							
25	1	10570H-11910	GASKET, NOZZLE	1							
26	1	105010-11920	COCK, WATER	1							
27	1	10570H-11940	PLATE, BAFFLE	1							
28	1	22217-100000	WASHER, SPRING 10	1							
29	1	26216-080222	STUD, M8X 22	4							
30	1	26216-080502	STUD, M8X 50	2							
31	1	26216-100552	STUD, M10X 55	1							
32	1	26366-080002	NUT, M8	2							
33	1	26716-100002	NUT, M10	1							
34	1	10570G-11650	BONNET SUB ASSY	1							
35	2	10530H-03550	LEVER ASSY, DECOMP.	1							
36	3	10530H-03610	SHAFT, DECOMP LEVER	1							
37	3	104104-03750	LEVER, DECOMPRESSION	1							
38	3	22322-030160	PIN, TAPER 3X16	1							
39	2	104200-03641	SPRING, DECOMPRESSION	1							
41	2	22312-030180	PIN, PARALLEL M3X18	1							
42	2	24311-000070	O-RING, 1AP7.0	1							
43	1	10570H-11310	PACKING, BONNET	1							
44	1	26106-060552	BOLT, M6X 55 PLATED	1							
45	1	26106-060702	BOLT, M6X 70 PLATED	2							
46	1	105700-11801	GUIDE, VALVE	2							1

Remarks

(1) Spare parts.

N:Old $\begin{matrix} \leftarrow \text{Yes} \\ \text{No} \end{matrix}$ New, Q:Old $\begin{matrix} \leftarrow \text{No} \\ \text{Yes} \end{matrix}$ New, R:Old $\begin{matrix} \leftarrow \text{Yes} \\ \text{Yes} \end{matrix}$ New, S:Old $\begin{matrix} \leftarrow \text{No} \\ \text{No} \end{matrix}$ New, W:Add, Z:Discontinued, F:Interchangeable by set, K:Q'ty Change

Fig.5. AIR CLEANER & MUFFLER

(A)=TF160LX
(B)=
(C)=

(D)=
(E)=
(F)=

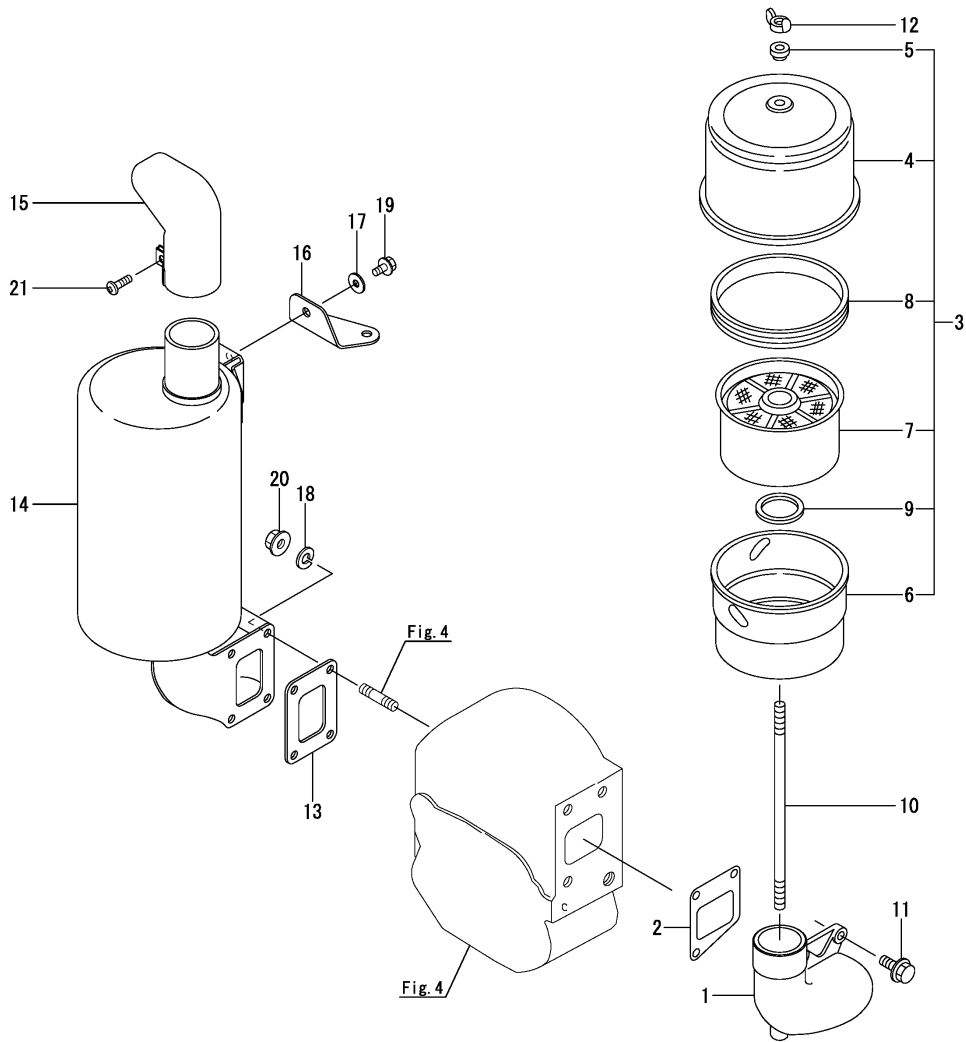

No.	Lev.	Parts No.	Description	Q'ty						I	R
				(A)	(B)	(C)	(D)	(E)	(F)		
1	1	10570H-12021	PIPE, AIR INTAKE	1							
2	1	105700-12050	GASKET	1							
3	1	10570H-12510	CLEANER ASSY, AIR	1							
4	2	10570H-12701	CAP, AIR CLEANER	1							
5	2	10570H-12710	WASHER, SEAL	1							
6	2	10570H-12750	BODY, AIR CLEANER	1							
7	2	10570H-12800	ELEMENT	1							
8	2	10570H-12850	GASKET, CAP	1							
9	2	10570H-12860	GASKET, AIR CLEANER	1							
10	1	10570H-12551	BOLT	1							
11	1	26106-080202	BOLT, M8X 20 PLATED	3							
12	1	26636-080002	NUT, WING M8	1							
13	1	105700-13201	GASKET, SILENCER	1							
14	1	10570H-13520	SILENCER	1							
15	1	10570H-13570	PIPE, EXHAUST	1							
16	1	10570H-13900	STIFFENER, SILENCER	1							
17	1	10540H-76940	WASHER	1							
18	1	22217-080000	WASHER, SPRING 8	4							
19	1	26106-060122	BOLT, M6X 12 PLATED	1							
20	1	26366-080002	NUT, M8	4							
21	1	26557-060202	SCREW, M6X20	1							

Fig.6. CAMSHAFT

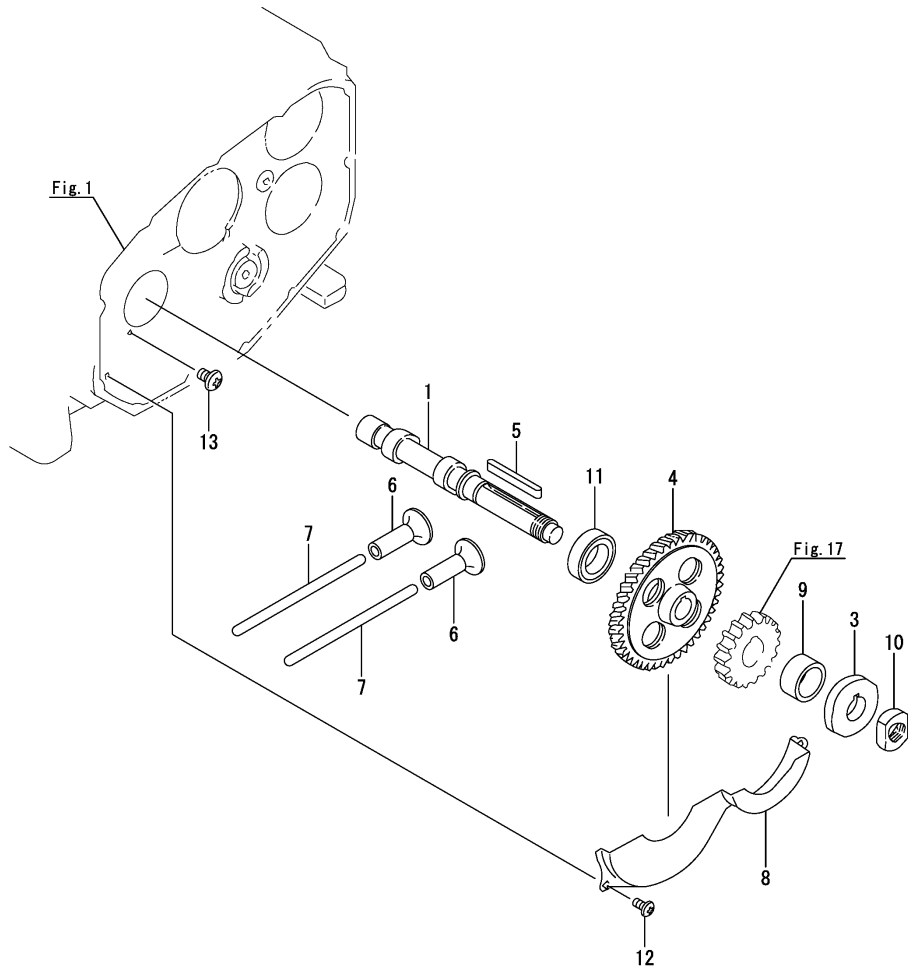

(A)=TF160LX
(B)=
(C)=

(D)=
(E)=
(F)=

No.	Lev.	Parts No.	Description	Q'ty						I	R
				(A)	(B)	(C)	(D)	(E)	(F)		
1	1	105700-14010	CAMSHAFT	1							
3	1	105700-14090	CAM, FUEL	1							
4	1	105700-14100	GEAR, CAMSHAFT	1							
5	1	10537H-14190	KEY, CAMSHAFT GEAR	1							
6	1	103854-14200	TAPPET	2							
7	1	10570H-14400	ROD, PUSH	2							
8	1	105700-14600	COVER	1							
9	1	10570H-14700	SPACER, CAMSHAFT	1							
10	1	104300-76460	NUT	1							
11	1	24101-060064	BEARING, BALL 6006	1							
12	1	26022-060122	SCREW, M6X12	3							
13	1	26587-080122	SCREW, M8X12	1							

Fig.7. CRANKSHAFT & FLYWHEEL

(A)=TF160LX
(B)=
(C)=

(D)=
(E)=
(F)=

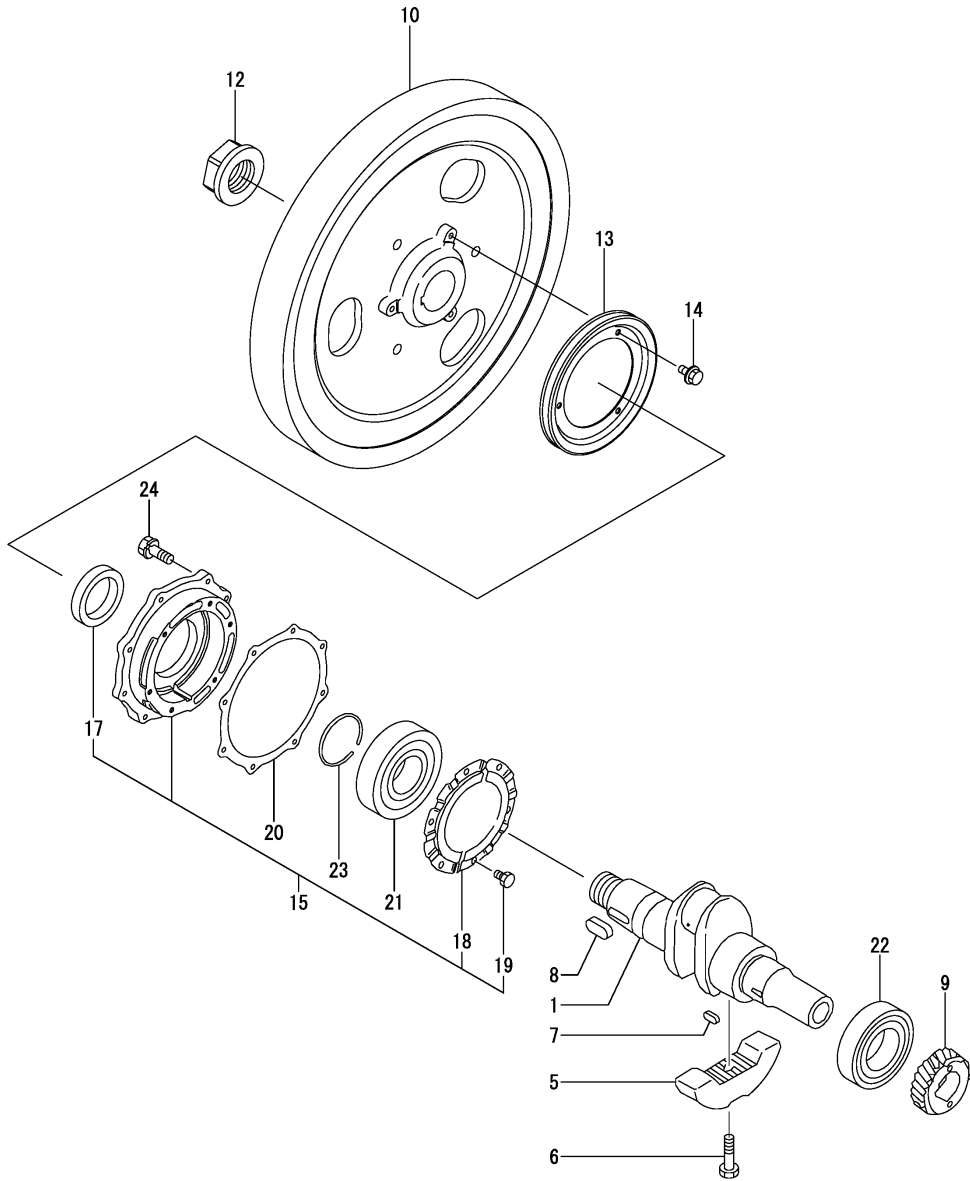

No.	Lev.	Parts No.	Description	Q'ty						I	R
				(A)	(B)	(C)	(D)	(E)	(F)		
1	1	105700-21010	CRANKSHAFT	1							
5	1	10570H-21100	WEIGHT, BALANCE	2							
6	1	104600-21130	BOLT	2							
7	1	10570H-21290	KEY	1							
8	1	10557H-21520	KEY, FLYWHEEL	1							
9	1	105700-21200	GEAR, CRANKSHAFT	1							
10	1	105700-21400	FLYWHEEL	1							
12	1	10550H-21530	NUT, END	1							
13	1	10510H-21600	V-PULLEY	1							
14	1	26106-060122	BOLT, M6X 12 PLATED	3							
15	1	705700-02500	HOUSING ASSY, METAL	1							
17	2	104700-02220	SEAL, OIL	1							
18	2	105700-02320	RETAINER	2							
19	2	26116-060102	BOLT, M6X 10 PLATED	6							
20	1	105700-02020	GASKET	1							
21	1	105800-02300	BEARING, 6312BG3C3	1							
22	1	10570H-02310	BEARING	1							
23	1	22242-000600	RING, 60	1							
24	1	26013-080202	BOLT, M8X 20	8							

Fig.8. PISTON & CONNECTING ROD

(A)=TF160LX
(B)=
(C)=

(D)=
(E)=
(F)=

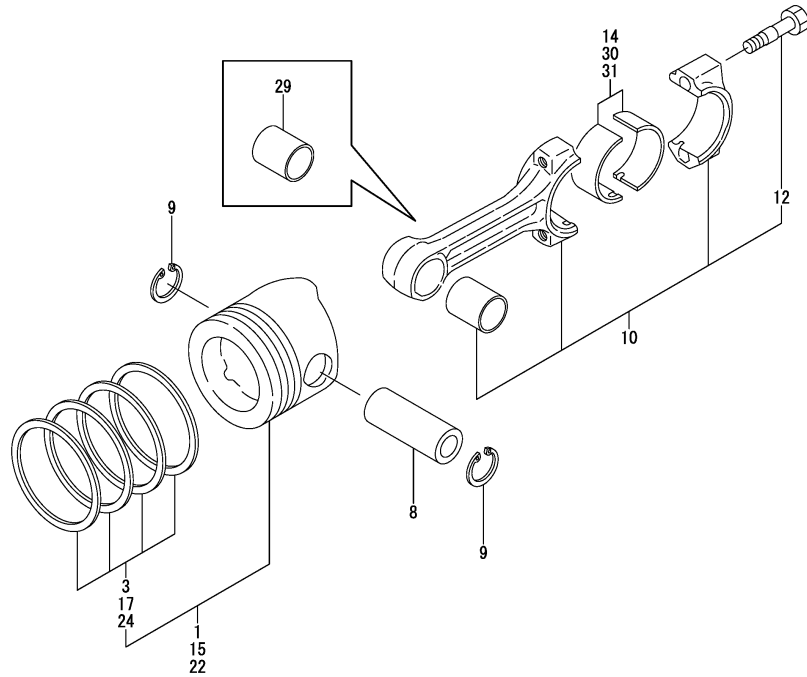

No.	Lev.	Parts No.	Description	Q'ty						I	R
				(A)	(B)	(C)	(D)	(E)	(F)		
1	1	105800-22090	PISTON ASSY	1							
3	2	704800-22502	RING SET, PISTON	1							
8	1	121850-22300	PIN, PISTON	1							
9	1	101400-22400	CIRCLIP	2							
10	1	105700-23011	ROD ASSY, CONNECTING	1							
12	2	121850-23200	BOLT, CONNECTING ROD	2							
14	1	10570H-23300	METAL, CRANK PIN	2							
15	1	105800-22470	PISTON ASSY, 0.25 OS	1							1
17	2	105800-22510	RING SET, 0.25 OS	1							1
22	1	105800-22480	PISTON ASSY, 0.50 OS	1							2
24	2	105800-22520	RING SET, 0.50 OS	1							2
29	1	105700-23910	BEARING, PISTON PIN	1							3
30	1	10570H-23350	METAL, CRANK PIN	2							4
31	1	10570H-23360	METAL, CRANK PIN	2							5

Remarks

- (1) Over-sized (O.S.=0.25) parts.
- (2) Over-sized (O.S.=0.5) parts.
- (3) Spare parts.
- (4) Under-sized (U.S.=0.25) parts.
- (5) Under-sized (U.S.=0.5) parts.

(A)=TF160LX
 (B)=
 (C)=

(D)=
 (E)=
 (F)=

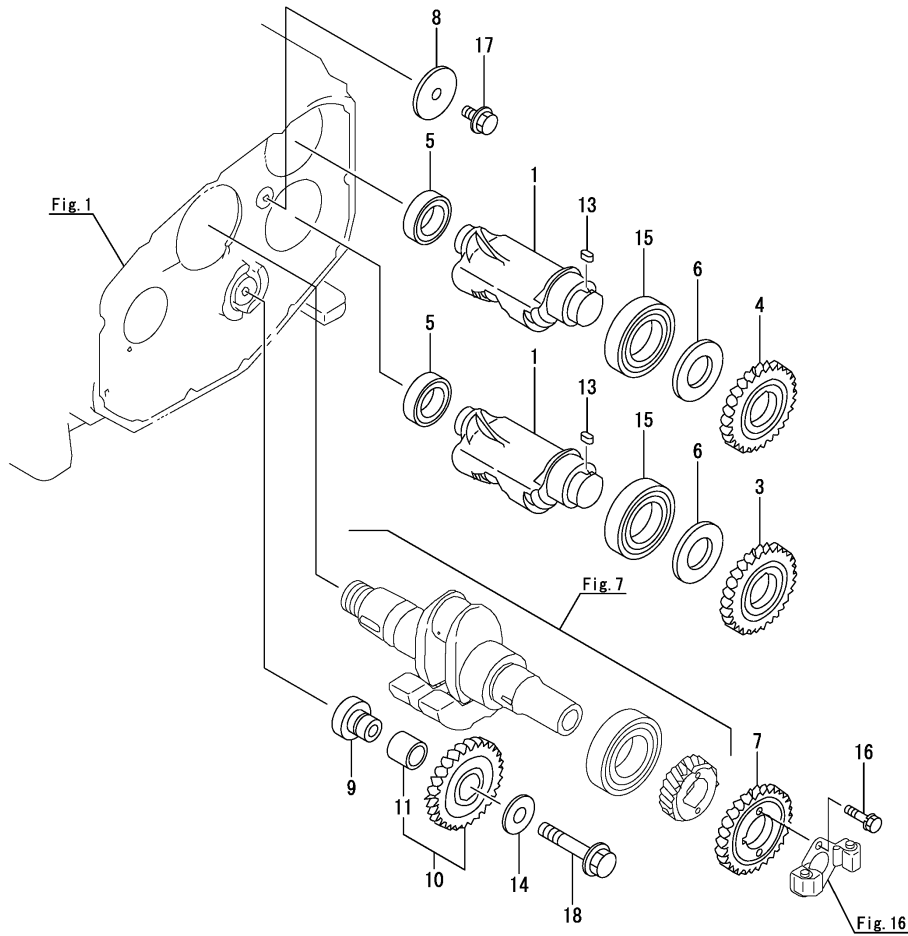

No.	Lev.	Parts No.	Description	Q'ty						I	R
				(A)	(B)	(C)	(D)	(E)	(F)		
1	1	105700-28251	SHAFT, BALANCER	2							
3	1	105700-28300	GEAR, BALANCER	1							
4	1	105700-28310	GEAR, BALANCER	1							
5	1	105700-28360	BEARING, 6205SH2	2							
6	1	105500-28380	SPACER	2							
7	1	105700-28410	GEAR, BALANCER	1							
8	1	105700-28451	RETAINER	1							
9	1	105300-28700	SHAFT	1							
10	1	105700-28710	GEAR ASSY, IDLE	1							
11	2	105430-28720	BUSH, IDLE GEAR	1							
13	1	105215-76490	KEY	2							
14	1	123672-83880	RETAINER	1							
15	1	24101-060104	BEARING, BALL 6010	2							
16	1	26013-060222	BOLT, M6X 22	2							
17	1	26106-080142	BOLT, M8X 14 PLATED	1							
18	1	26106-100552	BOLT, M10X 55 PLATED	1							

Fig.10. LUB. OIL SYSTEM

(A)=TF160LX
(B)=
(C)=

(D)=
(E)=
(F)=

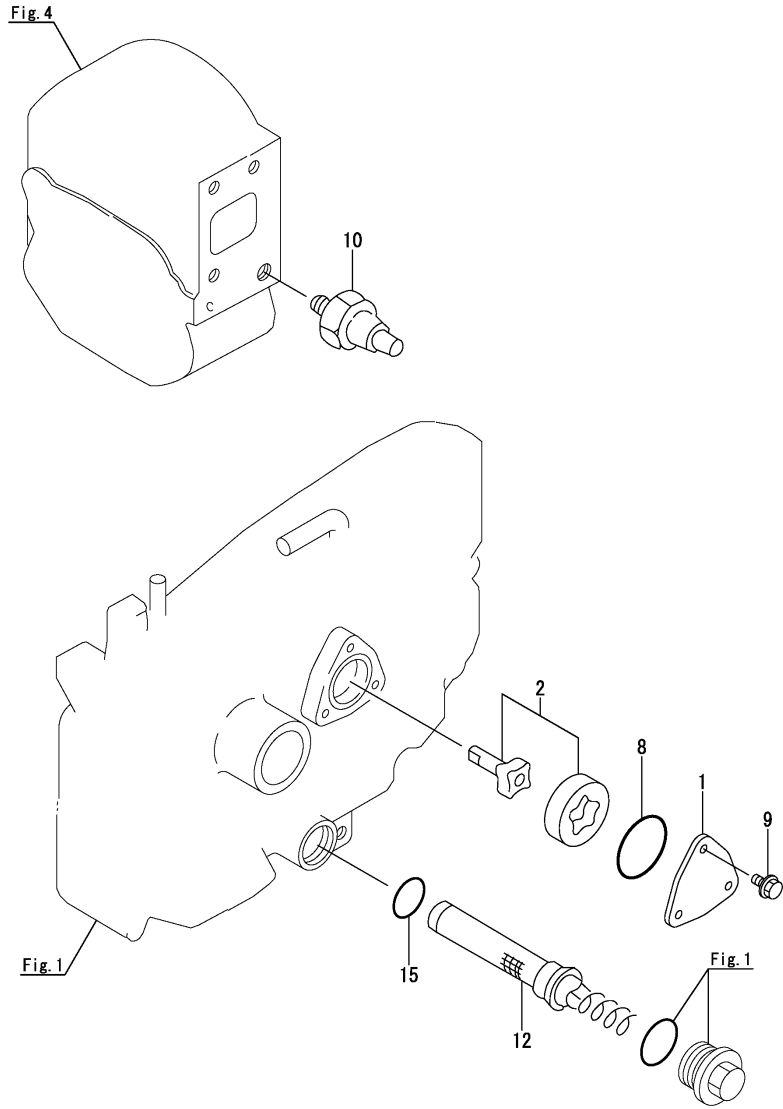

No.	Lev.	Parts No.	Description	Q'ty						I	R
				(A)	(B)	(C)	(D)	(E)	(F)		
1	1	103338-32070	COVER	1							
2	1	105500-32500	PUMP, LUB.OIL CMP	1							
8	1	103338-32570	O-RING	1							
9	1	26106-060122	BOLT, M6X 12 PLATED	3							
10	1	105582-34100	SIGNAL	1							
12	1	105700-35052	STRAINER ASSY, OIL	1							
15	1	24341-000200	O-RING, 1AS20.0	1							

Fig.11. RADIATOR

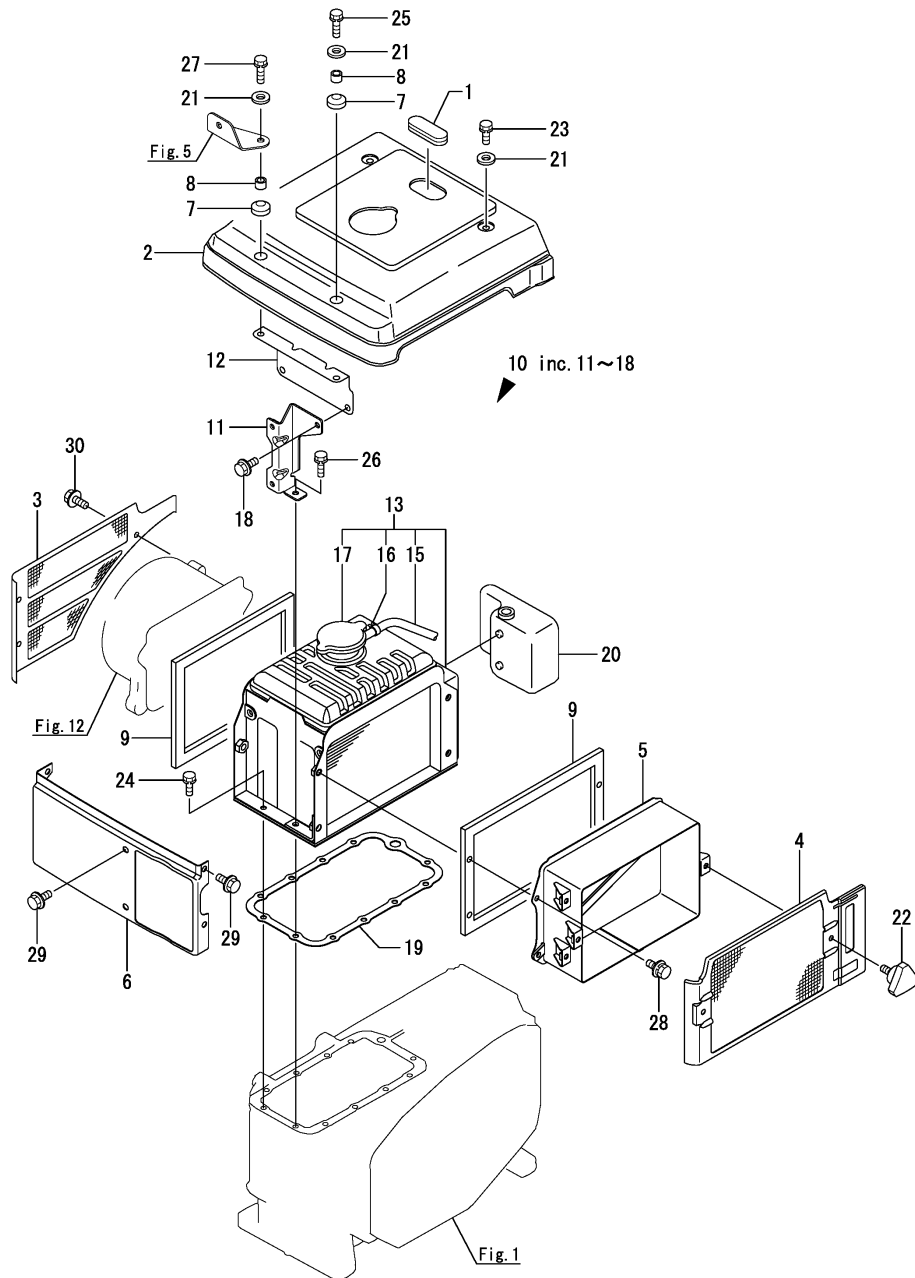

(A)=TF160LX
(B)=
(C)=

(D)=
(E)=
(F)=

No.	Lev.	Parts No.	Description	Q'ty						I	R
				(A)	(B)	(C)	(D)	(E)	(F)		
1	1	105300-44220	COVER, RADIATOR	1							
2	1	105700-44250	COVER, RADIATOR	1							
3	1	105700-44330	SCREEN	1							
4	1	10570H-44340	SCREEN	1							
5	1	10570H-44360	DUCT, SCREEN	1							
6	1	10570H-44370	COVER	1							
7	1	105300-44451	ABSORBER	2							
8	1	105300-44460	COLLAR	2							
9	1	104607-44540	SPONGE	2							
10	1	10570H-44600	RADIATOR ASSY, SUB	1							
11	2	10570H-44380	STAY	1							
12	2	10570H-44490	STAY, RADIATOR COVER	1							
13	2	10570H-44500	RADIATOR ASSY	1							
15	3	105640-44570	PIPE, 7X225	1							
16	3	121250-44590	CLAMP, HOSE	1							
17	3	10530H-44600	CAP, RADIATOR	1							
18	2	26106-060122	BOLT, M6X 12 PLATED	2							
19	1	10570H-44610	GASKET, RADIATOR	1							
20	1	10570H-44630	TANK, SUB	1							
21	1	10540H-76940	WASHER	4							
22	1	160725-78350	KNOB, BOLT M6X15	2							
23	1	26013-060142	BOLT, M6X 14	2							
24	1	26013-060162	BOLT, M6X 16	10							
25	1	26013-060182	BOLT, M6X 18	1							
26	1	26013-060202	BOLT, M6X 20	1							
27	1	26013-060202	BOLT, M6X 20	1							
28	1	26014-060142	BOLT, M6X 14	4							
29	1	26106-060122	BOLT, M6X 12 PLATED	6							
30	1	26106-060122	BOLT, M6X 12 PLATED	3							

Fig.12. FAN

(A)=TF160LX
(B)=
(C)=

(D)=
(E)=
(F)=

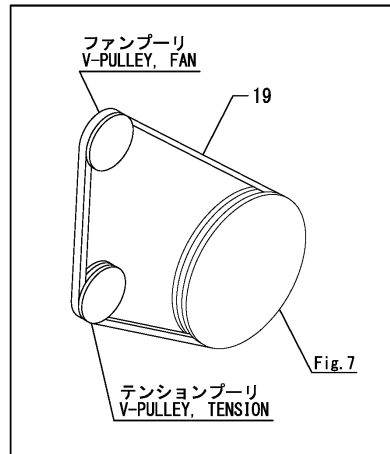
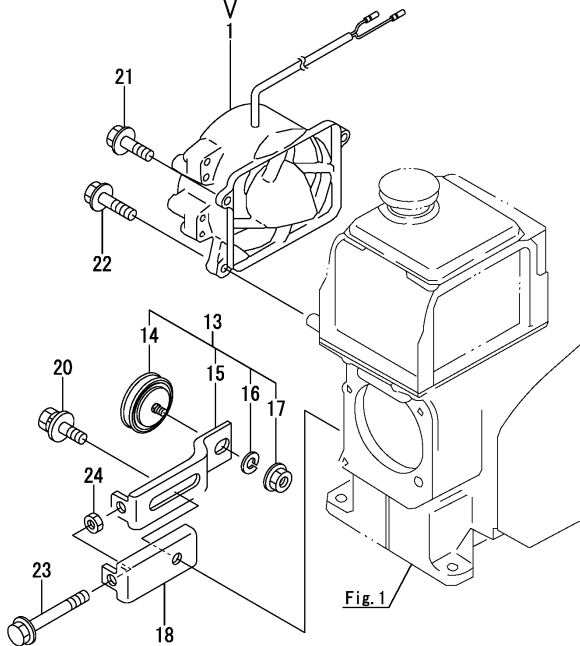
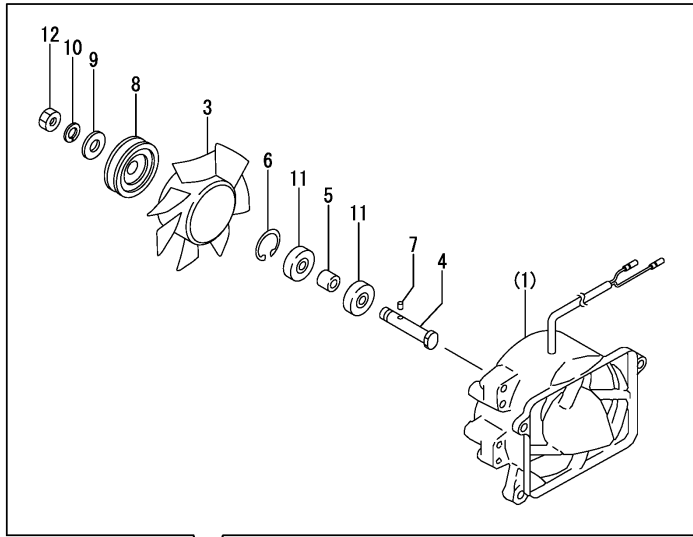

No.	Lev.	Parts No.	Description	Q'ty						I	R
				(A)	(B)	(C)	(D)	(E)	(F)		
1	1	10570H-44200	CASE ASSY, FAN	1							
3	2	105702-44700	FAN, COOLING	1							
4	2	105340-44710	SHAFT, FAN	1							
5	2	106383-44720	SPACER	1							
6	2	106383-44740	CIRCLIP	1							
7	2	105340-44750	PIN	1							
8	2	105100-44770	PULLEY, FAN	1							
9	2	105100-44780	WASHER, PULLEY	1							
10	2	22217-120000	WASHER, SPRING 12	1							
11	2	24107-062013	BEARING, 6201ZZP6	2							
12	2	26777-120002	NUT, LOCK M12	1							
13	1	10570H-44820	PULLEY ASSY, TENSION	1							
14	2	10610H-44651	PULLEY, TENSION	1							
15	2	10570H-44950	LEVER, TENSION PULLEY	1							
16	2	22217-080000	WASHER, SPRING 8	1							
17	2	26366-080002	NUT, M8	1							
18	1	105700-44951	LEVER, PULLEY	1							
19	1	25117-004101	V-BELT, M41H	1							
20	1	26014-080202	BOLT, M8X 20	1							
21	1	26106-080252	BOLT, M8X 25 PLATED	2							
22	1	26106-080302	BOLT, M8X 30 PLATED	2							
23	1	26106-080604	BOLT M 8X 60	1							
24	1	26756-080002	NUT, LOCK M8	1							

Fig.13. FUEL INJECTION PUMP

(A)=TF160LX
(B)=
(C)=

(D)=
(E)=
(F)=

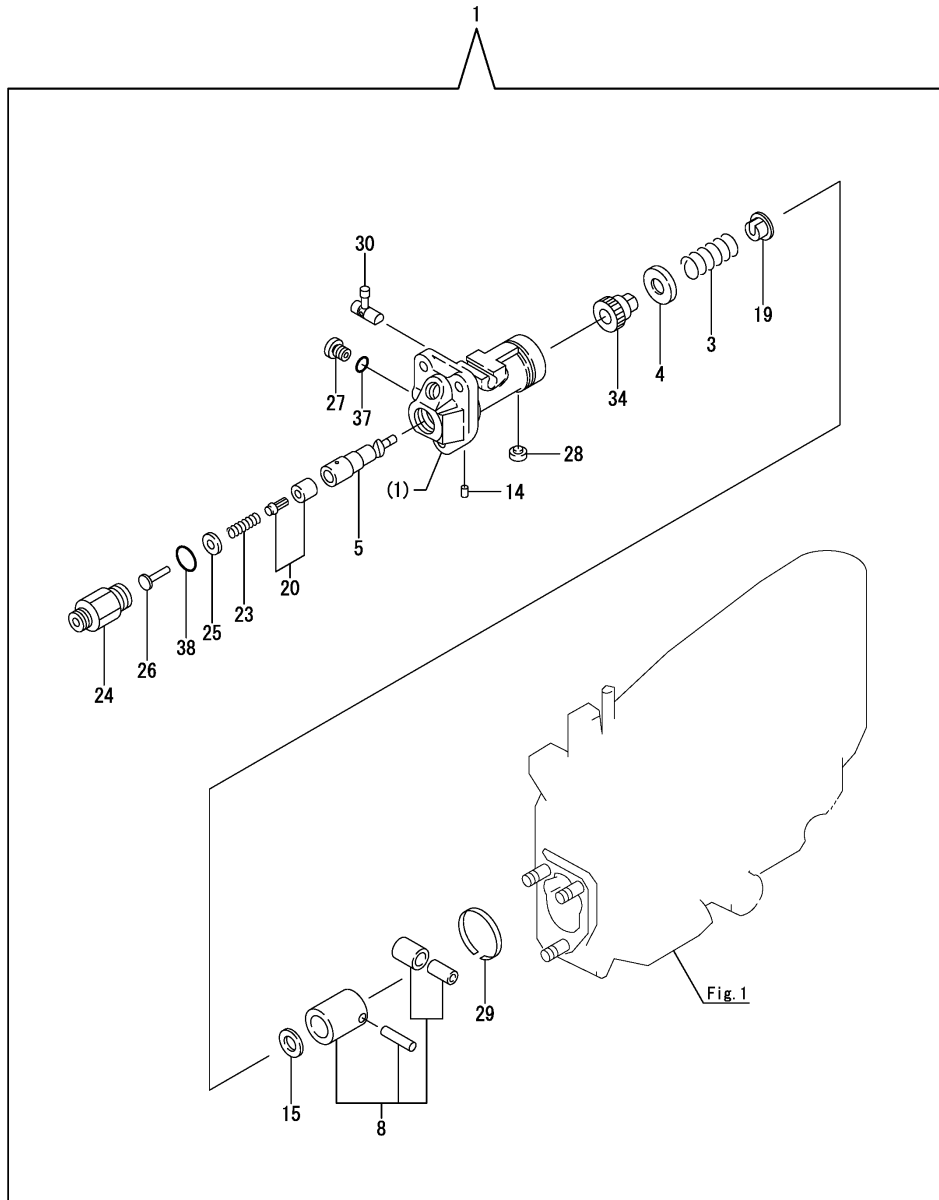

No.	Lev.	Parts No.	Description	Q'ty						I	R
				(A)	(B)	(C)	(D)	(E)	(F)		
1	1	70580H-51100	PUMP ASSY, INJECTION	1							
3	2	105990-51180	SPRING, PLUNGER	1							
4	2	105990-51190	RETAINER, SPRING A	1							
5	2	105700-51200	PLUNGER ASSY	1							
8	2	105990-51200	TAPPET ASSY	1							
14	2	103854-51251	PIN, PLUNGER	1							
15	2	105990-51250	SHIM SET	1							
19	2	105990-51290	RETAINER, SPRING B	1							
20	2	105700-51300	VALVE ASSY, DELIVERY	1							
23	2	121952-51330	SPRING, DELIVERY	1							
24	2	105990-51340	HOLDER	1							
25	2	122710-51350	GASKET	1							
26	2	121952-51370	STOPPER, VALVE	1							
27	2	105990-51400	PLUG, DEFLECTOR	1							
28	2	105990-51450	PIN	1							
29	2	103854-51460	CIRCLIP	1							
30	2	105700-51500	RACK ASSY, CONTROL	1							
34	2	105990-51550	SLEEVE, PINION	1							
37	2	24312-000060	O-RING, 2P6.0	1							
38	2	24312-000210	O-RING 2 P-21.0	1							

Fig.14. FUEL INJECTION DEVICE

(A)=TF160LX

(B)=

(C)=

(D)=

(E)=

(F)=

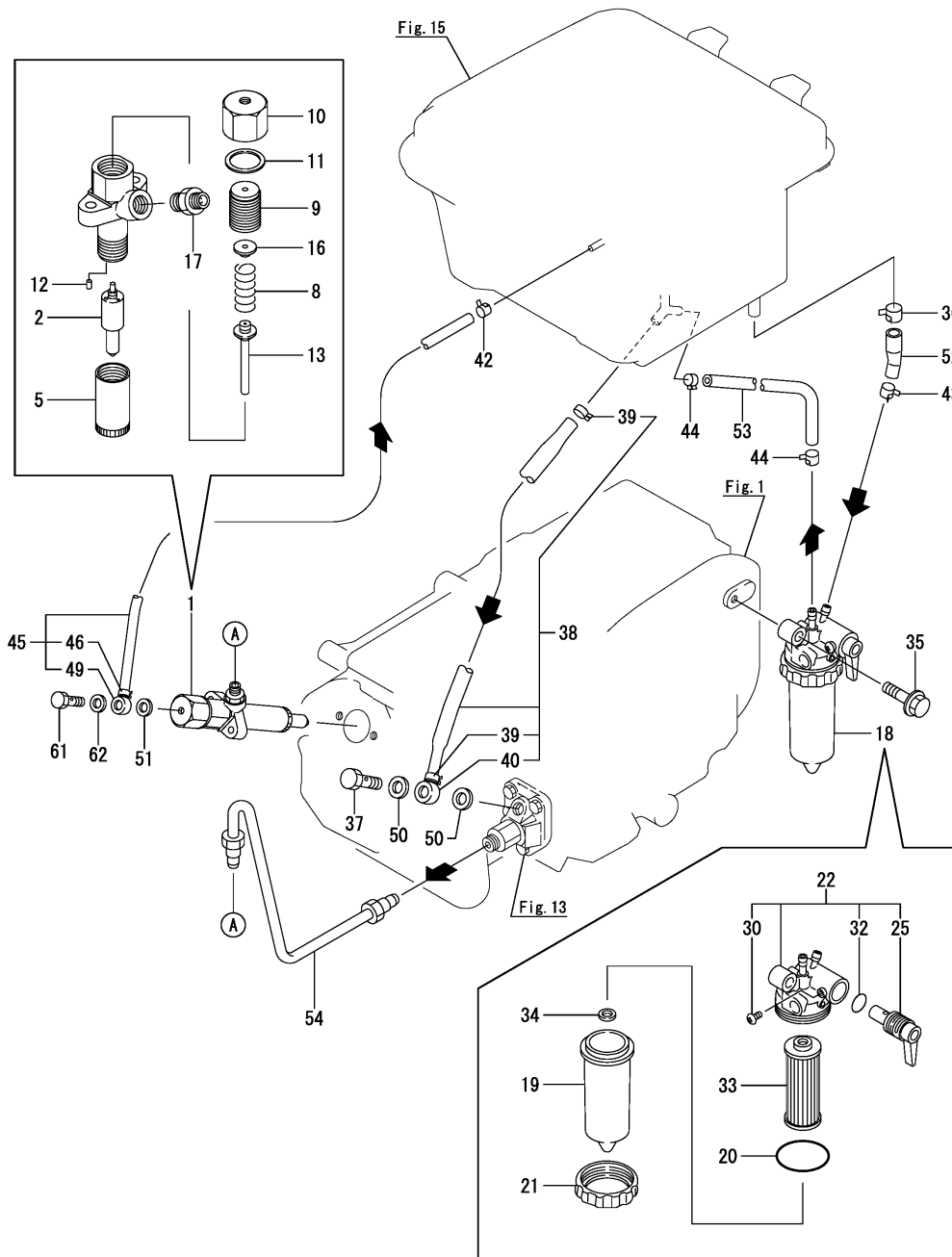

No.	Lev.	Parts No.	Description	Qty						I	R
				(A)	(B)	(C)	(D)	(E)	(F)		
1	1	705700-53100	VALVE ASSY,INJECTION	1							
2	2	105700-53000	VALVE ASSY,INJECTION	1							
5	2	126630-53080	NUT, NOZZLE L=48	1							
8	2	144626-53120	SPRING, NOZZLE	1							
9	2	144626-53181	HOLDER	1							
10	2	126630-53190	CAP, SPRING	1							
11	2	144626-53200	GASKET	1							
12	2	103200-53210	KNOCK, VALVE	2							
13	2	121850-53250	SPINDLE ASSY	1							
16	2	144626-53301	RETAINER, SPRING	1							
17	2	127610-53330	JOINT	1							
18	1	105198-55600	STRAINER ASSY, FUEL	1							
19	2	105198-55510	CUP, STRAINER	1							
20	2	105300-55520	O-RING	1							
21	2	105300-55610	RING, RETAINING	1							
22	2	105300-55700	BODY ASSY, STRAINER	1							
25	3	105300-55340	LEVER	1							
30	3	104200-55750	SCREW, PAN M4	1							
32	3	24311-000160	O-RING, 1AP16.0	1							
33	2	105370-55711	ELEMENT	1							
34	2	105300-55750	FLOAT	1							
35	1	26106-080302	BOLT, M8X 30 PLATED	1							
36	1	129301-03660	CLAMP 15	1							
37	1	103854-39140	BOLT, PIPE JOINT	1							
38	1	105700-59020	PIPE ASSY, FUEL	1							
39	2	129301-03660	CLAMP 15	2							
40	2	105800-59270	JOINT, PIPE 12	1							
42	1	124722-59050	CLAMP, HOSE 9	1							
43	1	124766-59050	CLAMP, HOSE 11.5	1							
44	1	124766-59050	CLAMP, HOSE 11.5	2							
45	1	105840-59140	PIPE ASSY, RETURN	1							
46	2	124722-59050	CLAMP, HOSE 9	1							
49	2	103854-59110	JOINT	1							
50	1	104200-59170	GASKET, 12	2							
51	1	104884-59170	GASKET	1							
52	1	105700-59561	PIPE, FUEL	1							
53	1	105700-59570	PIPE, FUEL	1							
54	1	105700-59800	PIPE ASSY, INJECTION	1							
61	1	101147-59810	BOLT, PIPE JOINT M8	1							
62	1	23414-080012	GASKET, 8X1.0	1							

Fig.15. FUEL TANK

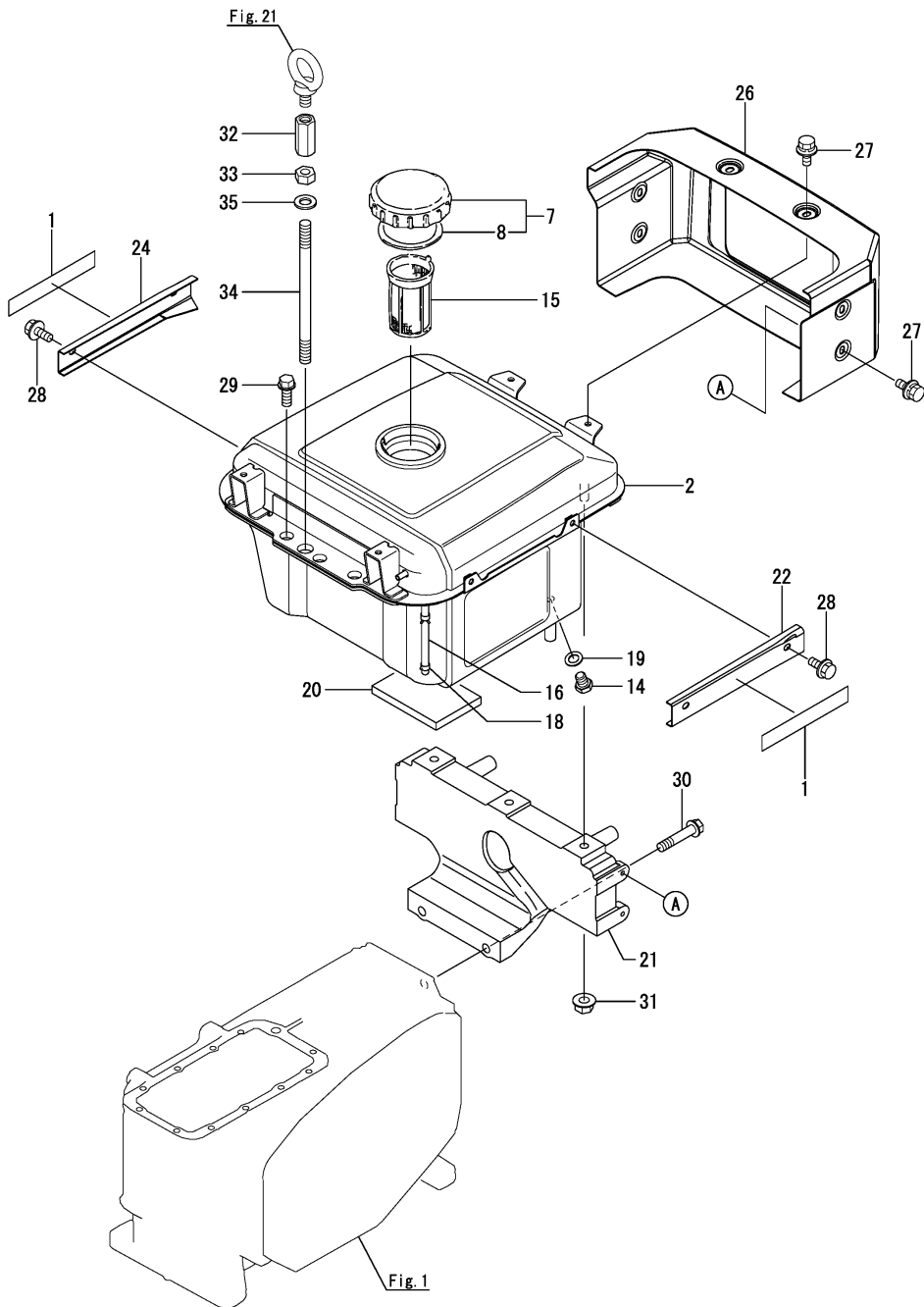

(A)=TF160LX
(B)=
(C)=

(D)=
(E)=
(F)=

No.	Lev.	Parts No.	Description	Q'ty						I	R
				(A)	(B)	(C)	(D)	(E)	(F)		
1	1	10580H-07100	LABEL, ENGINE MODEL	2							
2	1	10570H-55010	TANK ASSY, FUEL OIL	1							
7	1	10547H-55040	CAP, FUEL TANK	1							
8	2	10530H-55050	GASKET	1							
14	1	105300-55080	PLUG, 8	1							
15	1	101504-55101	STRAINER, FUEL	1							
16	1	104300-55160	GAUGE, LEVEL	1							
18	1	103854-55220	RETAINER	2							
19	1	23414-080000	GASKET, 8X1.0	1							
20	1	10570H-55210	SEAT, FELT	2							
21	1	10570H-55240	STAY	1							
22	1	10580H-55240	GUARD, LINE OFW	1							
24	1	10580H-55290	GUARD, LINE FW	1							
26	1	10570H-55810	COVER, LIGHT	1							
27	1	26014-060142	BOLT, M6X 14	6							
28	1	26106-060102	BOLT, M6X 10 PLATED	4							
29	1	26106-100202	BOLT, M10X 20 PLATED	2							
30	1	26106-100502	BOLT, M10X 50 PLATED	2							
31	1	26366-080002	NUT, M8	3							
32	1	105700-07910	NUT	1							
33	1	104507-07920	NUT, M12	1							
34	1	10550H-07940	BOLT, ENGINE LIFT	1							
35	1	22137-120000	WASHER, 12	1							

Fig.16. GOVERNOR & CONTROL EQUIPMENT

(A)=TF160LX

(B)=

(C)=

(D)=

(E)=

(F)=

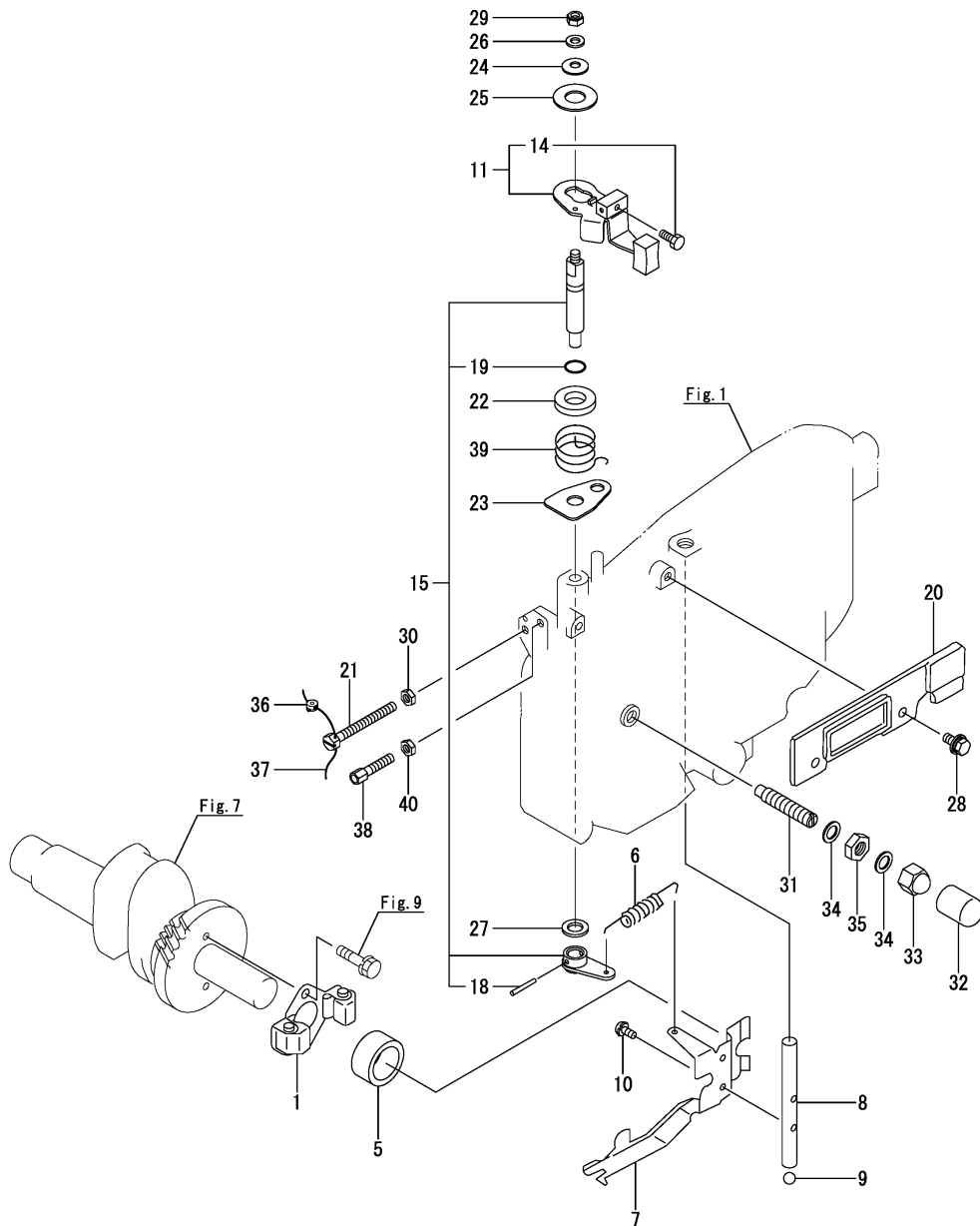

No.	Lev.	Parts No.	Description	Q'ty						I	R
				(A)	(B)	(C)	(D)	(E)	(F)		
1	1	705300-61701	GOVERNOR ASSY	1							
5	1	10530H-61600	SLEEVE, GOVERNOR	1							
6	1	10570H-66010	SPRING, REGULATOR	1							
7	1	105700-66300	LEVER, GOVERNOR	1							
8	1	105300-66400	SHAFT	1							
9	1	24190-120001	BALL, STEEL 3/8	1							
10	1	26022-050102	SCREW, M5X10	2							
11	1	10570H-66041	HANDLE ASSY, DECOMP.	1							
14	2	105225-66990	SCREW, M5X8.5	1							
15	1	705215-66700	LEVER ASSY,REGULATOR	1							
18	2	22322-030220	PIN, TAPER 3X22	1							
19	2	24311-000100	O-RING, 1AP10.0	1							
20	1	10570H-66110	COVER, HANDLE	1							
21	1	105300-66520	SCREW	1							
22	1	10570H-66830	PLATE, FRICTION	1							
23	1	10570H-66850	RETAINER	1							
24	1	10540H-66880	SPRING	1							
25	1	104600-76461	PIECE, DISTANCE	1							
26	1	22137-060000	WASHER, 6	1							
27	1	22137-100000	WASHER, 10	1							
28	1	26014-060142	BOLT, M6X 14	2							
29	1	26347-060002	NUT, M6	1							
30	1	26756-060002	NUT, LOCK M6	1							
31	1	10580H-66550	LIMITER, FO	1							
32	1	10530H-66610	CAP (F.O. LIMITTER	1							
33	1	124060-66950	NUT, CAP M10	1							
34	1	22190-100002	WASHER, SEAL 10	2							
35	1	26796-100002	NUT, LOCK M10	1							
36	1	114780-61090	TIN	1							
37	1	22451-060000	WIRE, 0.6	1							
38	1	102100-67080	BOLT, ADJUST	1							
39	1	105502-67301	SPRING, RETURN	1							
40	1	26756-060002	NUT, LOCK M6	1							

Fig.17. STARTING DEVICE

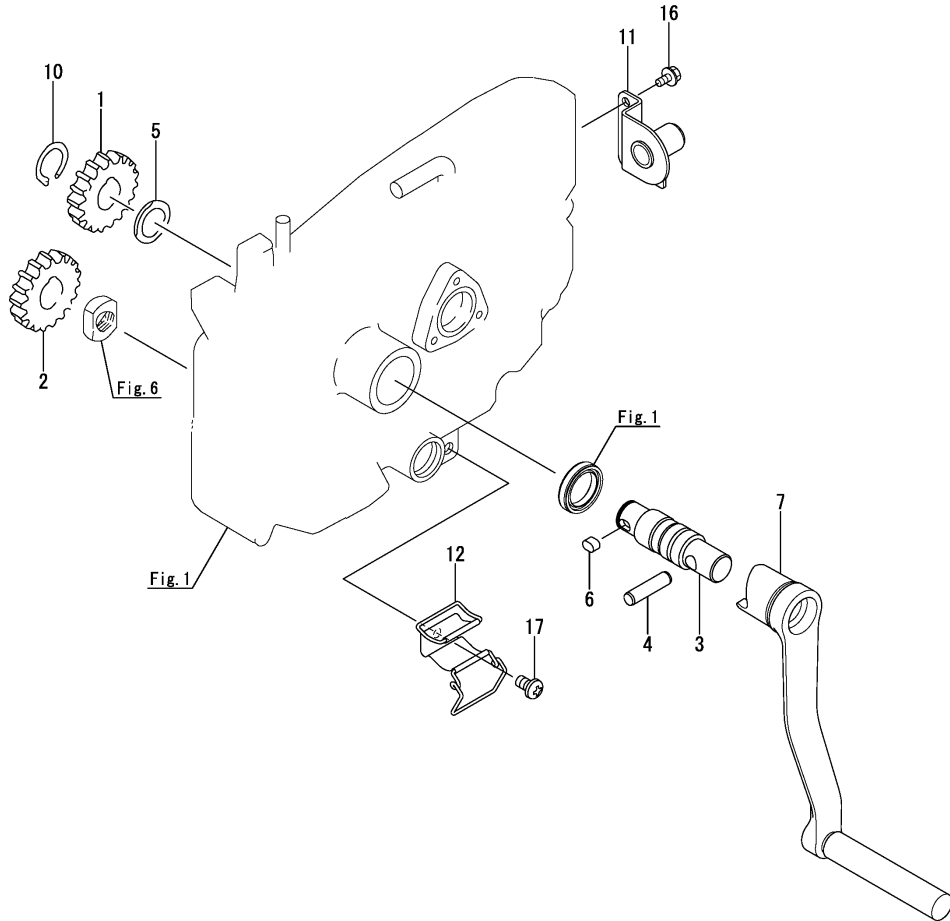

(A)=TF160LX
(B)=
(C)=

(D)=
(E)=
(F)=

No.	Lev.	Parts No.	Description	Q'ty						I	R
				(A)	(B)	(C)	(D)	(E)	(F)		
1	1	10530G-76330	GEAR, STARTING	1							
2	1	10530G-76330	GEAR, STARTING	1							
3	1	10570H-76340	SHAFT, STARTING	1							
4	1	10570H-76480	PIN, STARTING SHAFT	1							
5	1	105300-76470	COLLAR	1							
6	1	105300-76490	KEY, 7X10	1							
7	1	10570H-76790	HANDLE ASSY, START	1							
10	1	22242-000200	RING, 20	1							
11	1	10570H-08101	RETAINER, HANDLE	1							
12	1	10530G-08510	SPRING ASSY	1							
16	1	26106-060122	BOLT, M6X 12 PLATED	2							
17	1	26557-060102	SCREW, M6X10	1							

Fig.18. LAMP

(A)=TF160LX
(B)=
(C)=

(D)=
(E)=
(F)=

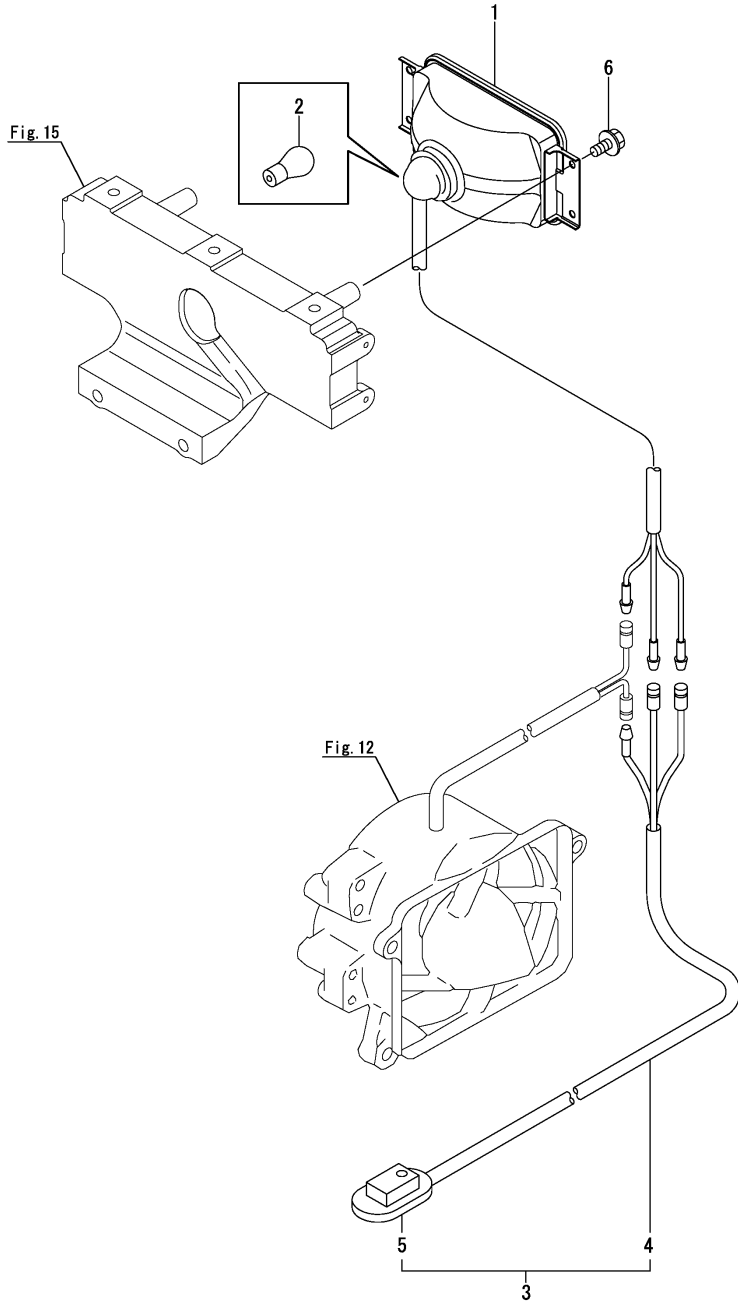

No.	Lev.	Parts No.	Description	Q'ty						I	R
				(A)	(B)	(C)	(D)	(E)	(F)		
1	1	10570H-78020	LAMP ASSY	1							
2	2	10530H-78250	BULB, 45W	1							
3	1	10530H-78520	SWITCH ASSY, RIGHT	1							
4	2	10530H-78530	HARNES, WIRE	1							
5	2	10530H-78960	SWITCH, LIGHT	1							
6	1	26014-060142	BOLT, M6X 14	4							

Fig.19. LABEL

(A)=TF160LX
(B)=
(C)=

(D)=
(E)=
(F)=

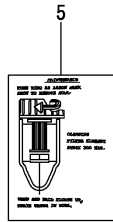
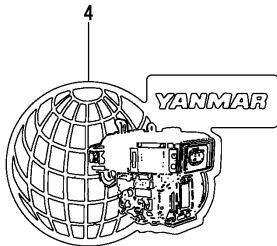
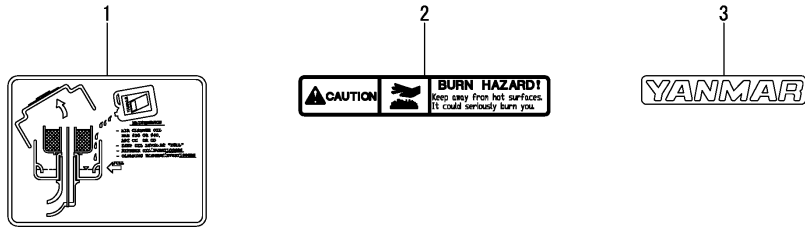

No.	Lev.	Parts No.	Description	Q'ty						I	R
				(A)	(B)	(C)	(D)	(E)	(F)		
1	1	10567H-07210	LABEL, AIR CLEANER	1							
2	1	10530H-07330	LABEL, CAUTION	1							
3	1	10530H-07530	LABEL, YANMAR	1							
4	1	10540H-07621	LABEL, YANMAR WORLD	1							
5	1	10567H-07640	LABEL, F.O.STRAINER	1							
6	1	10530H-07700	LABEL, CAUTION	1							
7	1	10530H-07750	LABEL, RADIATOR	1							
8	1	10530H-07771	LABEL, WARRANTY 2	1							

Fig.20. TOOL

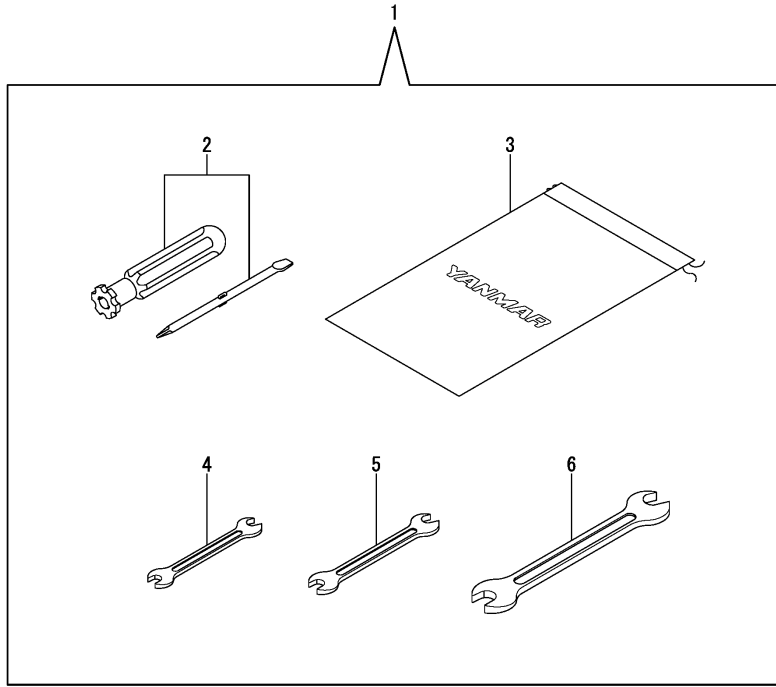

(A)=TF160LX
 (B)=
 (C)=

(D)=
 (E)=
 (F)=

No.	Lev.	Parts No.	Description	Q'ty						I	R
				(A)	(B)	(C)	(D)	(E)	(F)		
1	1	10530H-92100	TOOL SET CMP	1							
2	2	104200-92350	SCREW-DRIVER	1							
3	2	10530G-92600	BAG, TOOL	1							
4	2	28110-100120	SPANNER, 10X12	1							
5	2	28110-140170	SPANNER, 14X17	1							
6	2	28110-190220	SPANNER, 19X22	1							

Fig.21. BUNDLED ITEMS

(A)=TF160LX
(B)=
(C)=

(D)=
(E)=
(F)=

No.	Lev.	Parts No.	Description	Q'ty						I	R
				(A)	(B)	(C)	(D)	(E)	(F)		
1	1	22217-120000	WASHER, SPRING 12	3							
2	1	26206-120352	BOLT, M12X 35 PLATED	3							
3	1	26617-120002	BOLT, EYE M12	1							

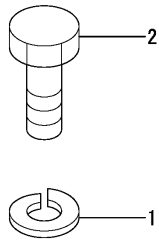

Parts No. Index

Parts No.	Fig. No.	Ref. No.
101104-01760	1	31
101147-59810	14	61
101158-03111	2	4
101400-22400	8	9
101504-55101	15	15
102100-67080	16	38
103200-53210	14	12
103338-32070	10	1
103338-32570	10	8
103854-01200	1	9
103854-01221	1	10
103854-11180	4	10
103854-11191	4	11
103854-11230	4	18
		22
103854-14200	6	6
103854-39140	14	37
103854-51251	13	14
103854-51460	13	29
103854-55220	15	18
103854-59110	14	49
104104-03750	4	37
104200-03641	4	39
104200-55750	14	30
104200-59170	14	50
104200-92350	20	2
104300-55160	15	16
104300-76460	6	10
104507-07920	15	33
104600-21130	7	6
104600-76461	16	25
104607-44540	11	9
104700-01240	1	11
104700-02220	7	17
104884-59170	14	51
105010-11920	4	26
105100-01660	1	20
105100-44770	12	8
105100-44780	12	9
10510H-21600	7	13
105198-55510	14	19
105198-55600	14	18
105215-76490	9	13
105225-66990	16	14
105300-01690	1	29
105300-11330	4	6
105300-28700	9	9
105300-34040	1	22
105300-44220	11	1
105300-44451	11	7

Parts No.	Fig. No.	Ref. No.
105300-44460	11	8
105300-55080	15	14
105300-55340	14	25
105300-55520	14	20
105300-55610	14	21
105300-55700	14	22
105300-55750	14	34
105300-66400	16	8
105300-66520	16	21
105300-76470	17	5
105300-76490	17	6
10530G-08510	17	12
10530G-76330	17	1
		2
10530G-92600	20	3
10530H-03550	4	35
10530H-03610	4	36
10530H-07330	19	2
10530H-07530	19	3
10530H-07700	19	6
10530H-07750	19	7
10530H-07771	19	8
10530H-44600	11	17
10530H-55050	15	8
10530H-61600	16	5
10530H-66610	16	32
10530H-78250	18	2
10530H-78520	18	3
10530H-78530	18	4
10530H-78960	18	5
10530H-92100	20	1
105340-44710	12	4
105340-44750	12	7
105362-78960	2	5
105370-55711	14	33
10537H-03060	2	2
10537H-14190	6	5
10540H-07621	19	4
10540H-66880	16	24
10540H-76940	5	17
	11	21
105430-28720	9	11
10547H-55040	15	7
105500-28380	9	6
105500-32500	10	2
105502-67301	16	39
10550H-01481	1	27
10550H-01490	1	28
10550H-07940	15	34
10550H-21530	7	12

Parts No.	Fig. No.	Ref. No.
10557H-21520	7	8
105582-34100	10	10
105640-44570	11	15
10567H-07210	19	1
10567H-07640	19	5
105700-01300	1	8
105700-01410	1	26
105700-02020	7	20
105700-02320	7	18
105700-03132	2	7
105700-07910	15	32
105700-08010	3	1
105700-08020	3	2
105700-08050	3	3
105700-11100	4	7
105700-11111	4	8
105700-11290	4	13
105700-11801	4	46
105700-12050	5	2
105700-13201	5	13
105700-14010	6	1
105700-14090	6	3
105700-14100	6	4
105700-14600	6	8
105700-21010	7	1
105700-21200	7	9
105700-21400	7	10
105700-23011	8	10
105700-23910	8	29
105700-28251	9	1
105700-28300	9	3
105700-28310	9	4
105700-28360	9	5
105700-28410	9	7
105700-28451	9	8
105700-28710	9	10
105700-35052	10	12
105700-44250	11	2
105700-44330	11	3
105700-44951	12	18
105700-51200	13	5
105700-51300	13	20
105700-51500	13	30
105700-53000	14	2
105700-59020	14	38
105700-59561	14	52
105700-59570	14	53
105700-59800	14	54
105700-66300	16	7
105702-44700	12	3

Parts No.	Fig. No.	Ref. No.
10570G-11650	4	34
10570H-01331	1	12
10570H-01340	1	13
10570H-01392	1	14
10570H-01750	1	30
10570H-01850	1	32
10570H-02310	7	22
10570H-03070	2	1
10570H-08101	17	11
10570H-11120	4	9
10570H-11310	4	43
10570H-11650	4	16
10570H-11660	4	20
10570H-11910	4	25
10570H-11940	4	27
10570H-12021	5	1
10570H-12510	5	3
10570H-12551	5	10
10570H-12701	5	4
10570H-12710	5	5
10570H-12750	5	6
10570H-12800	5	7
10570H-12850	5	8
10570H-12860	5	9
10570H-13520	5	14
10570H-13570	5	15
10570H-13900	5	16
10570H-14400	6	7
10570H-14700	6	9
10570H-21100	7	5
10570H-21290	7	7
10570H-23300	8	14
10570H-23350	8	30
10570H-23360	8	31
10570H-44200	12	1
10570H-44340	11	4
10570H-44360	11	5
10570H-44370	11	6
10570H-44380	11	11
10570H-44490	11	12
10570H-44500	11	13
10570H-44600	11	10
10570H-44610	11	19
10570H-44630	11	20
10570H-44820	12	13
10570H-44950	12	15
10570H-55010	15	2
10570H-55210	15	20
10570H-55240	15	21
10570H-55810	15	26

Parts No. Index

Parts No.	Fig. No.	Ref. No.
10570H-66010	16	6
10570H-66041	16	11
10570H-66110	16	20
10570H-66830	16	22
10570H-66850	16	23
10570H-76340	17	3
10570H-76480	17	4
10570H-76790	17	7
10570H-78020	18	1
10571H-61250	1	25
105800-02300	7	21
105800-22090	8	1
105800-22470	8	15
105800-22480	8	22
105800-22510	8	17
105800-22520	8	24
105800-59270	14	40
10580H-07100	15	1
10580H-55240	15	22
10580H-55290	15	24
10580H-66550	16	31
105840-59140	14	45
105990-51180	13	3
105990-51190	13	4
105990-51200	13	8
105990-51250	13	15
105990-51290	13	19
105990-51340	13	24
105990-51400	13	27
105990-51450	13	28
105990-51550	13	34
10610H-44651	12	14
106383-44720	12	5
106383-44740	12	6
114780-61090	16	36
121250-44590	11	16
121850-22300	8	8
121850-23200	8	12
121850-53250	14	13
121952-51330	13	23
121952-51370	13	26
122710-51350	13	25
123672-83880	9	14
124060-66950	16	33
124722-59050	14	42
		46
124766-59050	14	43
		44
126630-53080	14	5
126630-53190	14	10

Parts No.	Fig. No.	Ref. No.
127610-53330	14	17
128610-11900	4	24
129301-03660	14	36
		39
144626-53120	14	8
144626-53181	14	9
144626-53200	14	11
144626-53301	14	16
160725-78350	11	22
22137-060000	16	26
22137-100000	16	27
22137-120000	15	35
22190-100002	16	34
22217-040000	2	6
22217-080000	5	18
	12	16
22217-100000	4	28
22217-120000	12	10
	21	1
22217-140000	3	4
22242-000200	17	10
22242-000600	7	23
22252-000100	1	23
22312-030180	4	41
22322-030160	4	38
22322-030220	16	18
22351-060012	1	4
		21
22451-060000	16	37
23064-110450	2	8
23414-080000	15	19
23414-080012	14	62
24101-060064	6	11
24101-060104	9	15
24107-062013	12	11
24190-120001	1	24
	16	9
24311-000060	1	46
24311-000070	4	42
24311-000100	16	19
24311-000160	14	32
24312-000060	13	37
24312-000210	13	38
24321-000250	1	47
24341-000200	10	15
25117-004101	12	19
26013-060142	11	23
26013-060162	11	24
26013-060182	11	25
26013-060202	11	26

Parts No.	Fig. No.	Ref. No.
26013-060202	11	27
26013-060222	9	16
26013-080202	7	24
26014-060142	11	28
	15	27
	16	28
	18	6
26014-080202	12	20
26022-050102	16	10
26022-060122	6	12
26106-060102	15	28
26106-060122	5	19
	7	14
	10	9
	11	18
		29
		30
	17	16
26106-060142	1	48
26106-060222	2	9
26106-060552	4	44
26106-060702	4	45
26106-080142	9	17
26106-080202	5	11
26106-080252	12	21
26106-080302	12	22
	14	35
26106-080352	1	49
26106-080604	12	23
26106-080752	1	50
26106-100202	15	29
26106-100502	15	30
26106-100552	9	18
26116-060102	7	19
26206-120352	21	2
26216-080222	1	51
	4	29
26216-080502	4	30
26216-100552	4	31
26347-060002	16	29
26366-080002	1	52
	4	32
	5	20
	12	17
	15	31
26557-060102	17	17
26557-060202	5	21
26587-080122	6	13
26617-120002	21	3
26636-080002	5	12

Parts No.	Fig. No.	Ref. No.
26716-100002	4	33
26716-140002	3	5
26756-060002	16	30
		40
26756-080002	12	24
26777-120002	12	12
26796-100002	4	19
		23
	16	35
28110-100120	20	4
28110-140170	20	5
28110-190220	20	6
704800-22502	8	3
705215-66700	16	15
705300-61701	16	1
705700-01561	1	1
705700-02500	7	15
705700-53100	14	1
705706-11701	4	1
705800-01900	1	5
70580H-51100	13	1