

0CC50-M00750EN

# Introduction

1. This parts catalog is a first edition of the TF115HM diesel engine.

	Date of issue	Remarks
First edition	Mar., 2016	

2. This parts catalog does not contain the technical data needed for maintenance service.

3. The illustrations used in this parts catalog have been simplified for clarity.

4. The contents of this parts catalog are subject to change without notice.

5. Be sure to use only Yanmar genuine parts for repairs. If imitation parts are used, it may cause engine defects.

# Contents

OCC50-M00750

Fig. No. Fig. Name

Fig. No. Fig. Name

TF115HM

1. CYLINDER BLOCK
2. BREATHER
3. ENGINE BED
4. CYLINDER HEAD & BONNET
5. AIR CLEANER & MUFFLER
6. CAMSHAFT
7. CRANKSHAFT & FLYWHEEL
8. PISTON & CONNECTING ROD
9. BALANCER
10. LUB. OIL SYSTEM
11. HOPPER
12. FUEL INJECTION PUMP
13. FUEL INJECTION DEVICE
14. FUEL TANK
15. GOVERNOR & CONTROL EQUIPMENT
16. STARTING DEVICE
17. LABEL
18. TOOL
19. BUNDLED ITEMS
20. GASKET SET(OPTIONAL)

Fig.1. CYLINDER BLOCK

(A)=TF115HM  
(B)=  
(C)=

(D)=  
(E)=  
(F)=

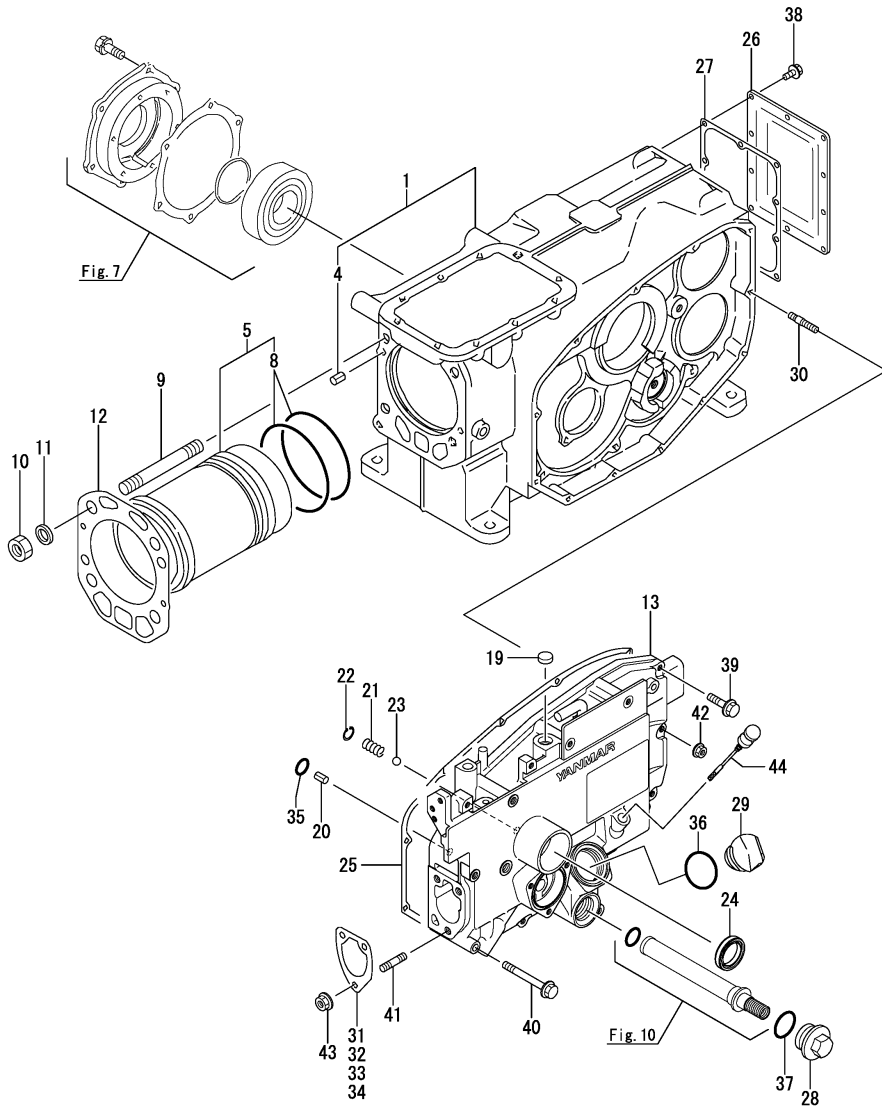

No.	Lev.	Parts No.	Description	Q'ty						I	R
				(A)	(B)	(C)	(D)	(E)	(F)		
1	1	105600-01560	BODY, CYLINDER SUB A	1							
4	2	22351-060012	PIN, SPRING 6.0X12	2							
5	1	10560H-01900	LINER,CYLINDER SUB A	1							
8	2	10550H-01300	O-RING, CYL. LINER	2							A
9	1	105500-01200	BOLT, HEAD	4							
10	1	104300-01220	NUT, CYLINDER HEAD	4							
11	1	103338-01240	WASHER	4							
12	1	10557H-01330	GASKET, HEAD	1							A
13	1	10560H-01390	CASE ASSY, GEAR	1							
19	1	105100-01660	PLUG, 14	1							
20	1	22351-060012	PIN, SPRING 6.0X12	1							
21	1	105300-34040	SPRING	1							
22	1	22252-000100	RING, 10	1							
23	1	24190-120001	BALL, STEEL 3/8	1							
24	1	10571H-61250	SEAL,OIL START SHAFT	1							
25	1	105500-01410	GASKET	1							A
26	1	10550H-01481	COVER, REAR	1							
27	1	10550H-01490	GASKET, REAR COVER	1							
28	1	105300-01690	PLUG	1							
29	1	10540H-01751	CAP, FEEDER	1							
30	1	10530H-01800	BOLT	1							
31	1	10530H-01920	SHIM, T=0.3	1							
32	1	10530H-01950	SHIM, T=0.5	1							
33	1	10530H-01960	SHIM, T=0.4	1							
34	1	10530H-01970	SHIM, T=0.6	1							
35	1	24311-000060	O-RING, 1AP6.0	1							
36	1	24311-000320	O-RING, 1AP32.0	1							A
37	1	24321-000250	O-RING, 1AG25.0	1							
38	1	26106-060142	BOLT, M6X 14 PLATED	10							
39	1	26106-060252	BOLT, M6X 25 PLATED	6							
40	1	26106-060652	BOLT, M6X 65 PLATED	6							
41	1	26216-080222	STUD, M8X 22	3							
42	1	26366-060002	NUT, M6	1							
43	1	26366-080002	NUT, M8	3							
44	1	10530H-34850	DIPSTICK, OIL	1							

Remarks

(A)Gasket kit is shown in Fig.20.

Fig.2. BREATHER

(A)=TF115HM  
(B)=  
(C)=

(D)=  
(E)=  
(F)=

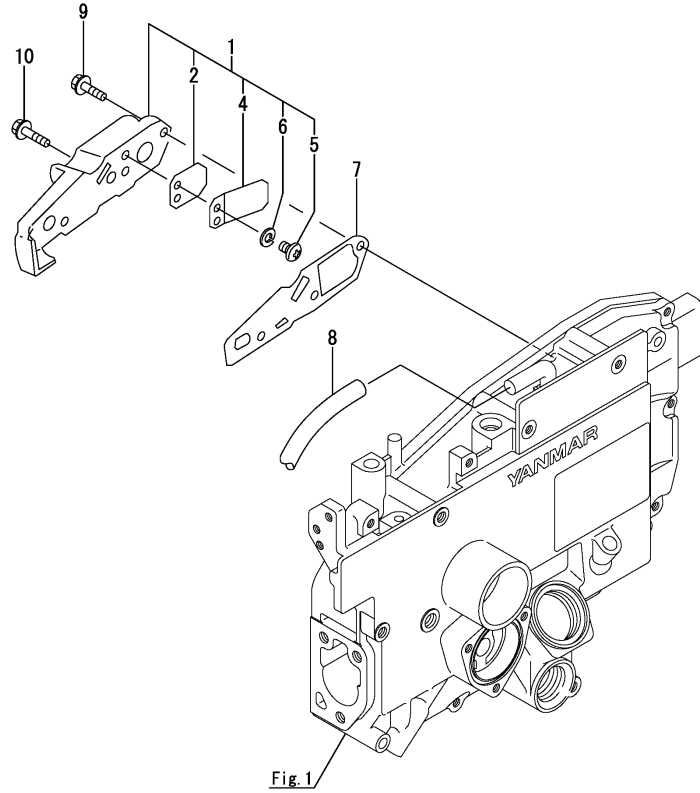

No.	Lev.	Parts No.	Description	Q'ty						I	R
				(A)	(B)	(C)	(D)	(E)	(F)		
1	1	10550H-03070	COVER ASSY, BREATHER	1							
2	2	10537H-03060	VALVE, RETURN	1							
4	2	101158-03111	RETAINER	1							
5	2	105362-78960	SCREW, M4X8	2							
6	2	22217-040000	WASHER, SPRING 4	2							
7	1	105500-03130	GASKET, BREATHER	1							
8	1	23064-090330	HOSE, 9 X 330	1							
9	1	26106-060222	BOLT, M6X 22 PLATED	2							
10	1	26106-060252	BOLT, M6X 25 PLATED	1							

Fig.3. ENGINE BED

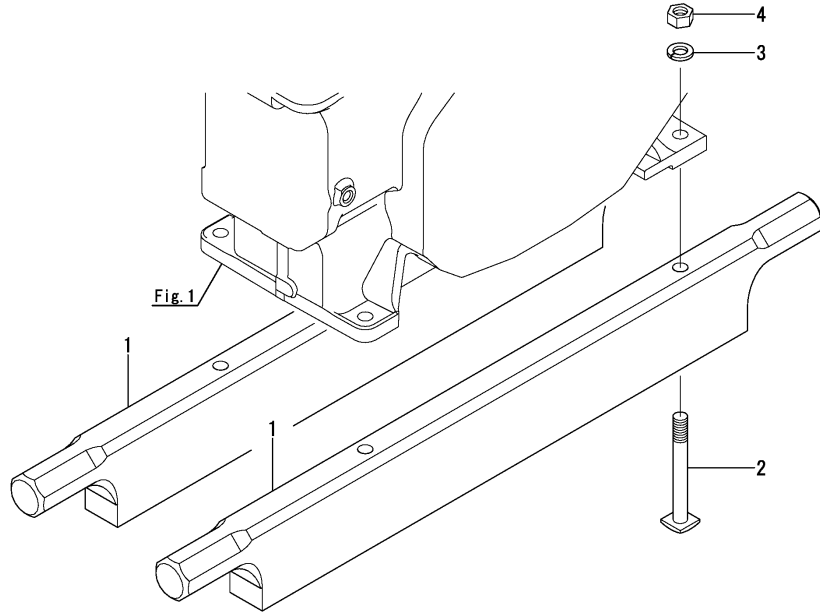

(A)=TF115HM  
 (B)=  
 (C)=

(D)=  
 (E)=  
 (F)=

No.	Lev.	Parts No.	Description	Q'ty						I	R
				(A)	(B)	(C)	(D)	(E)	(F)		
1	1	10550H-08020	BED, ENGINE	2							
2	1	104300-08050	BOLT, FOUNDATION	4							
3	1	22217-120000	WASHER, SPRING 12	4							
4	1	26706-120002	NUT, M12	4							

---

---

---

---

---

---

---

---

---

---

---

---

---

---

---

---

---

---

---

---

---

---

---

---

---

---

Fig.4. CYLINDER HEAD & BONNET

(A)=TF115HM

(B)=

(C)=

(D)=

(E)=

(F)=

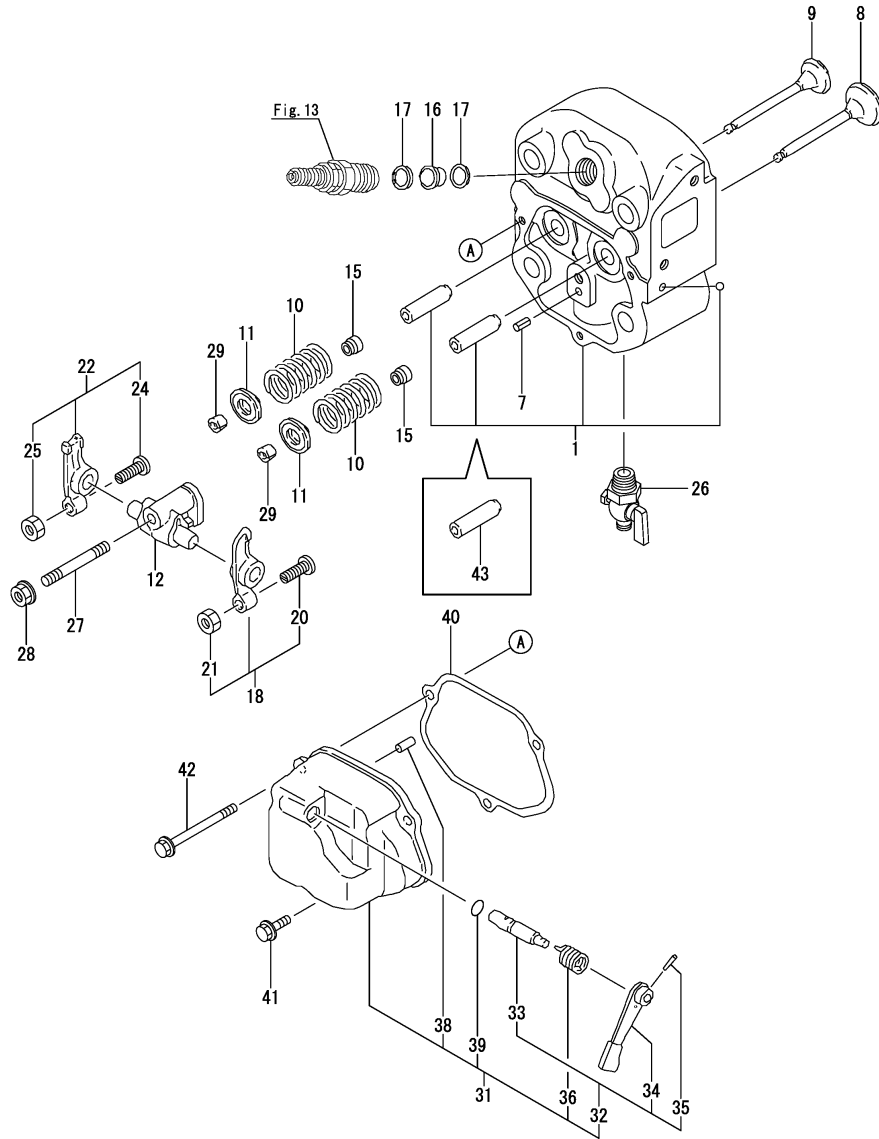

No.	Lev.	Parts No.	Description	Q'ty						I	R
				(A)	(B)	(C)	(D)	(E)	(F)		
1	1	10567H-11010	HEAD ASSY, CYLINDER	1							
7	1	22351-060012	PIN, SPRING 6.0X12	1							
8	1	105500-11100	VALVE, INTAKE	1							
9	1	105500-11111	VALVE, EXHAUST	1							
10	1	10557H-11120	SPRING, VALVE	2							
11	1	103338-11180	RETAINER, SPRING	2							
12	1	10550H-11290	SUPPORT ASSY, ARM	1							
15	1	105500-11340	SEAL, VALVE STEM	2							
16	1	119600-11450	PROTECTOR, NOZZLE	1							A
17	1	119600-11460	GASKET, NOZZLE	2							
18	1	10550H-11650	ARM ASSY, INTAKE	1							
20	2	101158-11230	SCREW, VALVE ADJUST	1							
21	2	26756-080002	NUT, LOCK M8	1							
22	1	10550H-11660	ARM ASSY, EXHAUST	1							
24	2	101158-11230	SCREW, VALVE ADJUST	1							
25	2	26756-080002	NUT, LOCK M8	1							
26	1	105010-11920	COCK, WATER	1							
27	1	26216-080502	STUD, M8X 50	1							
28	1	26366-080002	NUT, M8	1							
29	1	27310-080001	COTTER, 8	2							
31	1	10550H-11520	BONNET ASSY	1							
32	2	10530H-03550	LEVER ASSY, DECOMP.	1							
33	3	10530H-03610	SHAFT, DECOMP LEVER	1							
34	3	104104-03750	LEVER, DECOMPRESSION	1							
35	3	22322-030160	PIN, TAPER 3X16	1							
36	2	104200-03641	SPRING, DECOMPRESSION	1							
38	2	22312-030180	PIN, PARALLEL M3X18	1							
39	2	24311-000070	O-RING, 1AP7.0	1							A
40	1	10550H-11310	GASKET	1							A
41	1	26106-060202	BOLT, M6X 20 PLATED	2							
42	1	26106-060702	BOLT, M6X 70 PLATED	1							
43	1	105500-11190	GUIDE, VALVE	2							1

Remarks

(A) Gasket kit is shown in Fig.20.

(1) Spare parts.

Fig.5. AIR CLEANER & MUFFLER

(A)=TF115HM  
(B)=  
(C)=

(D)=  
(E)=  
(F)=

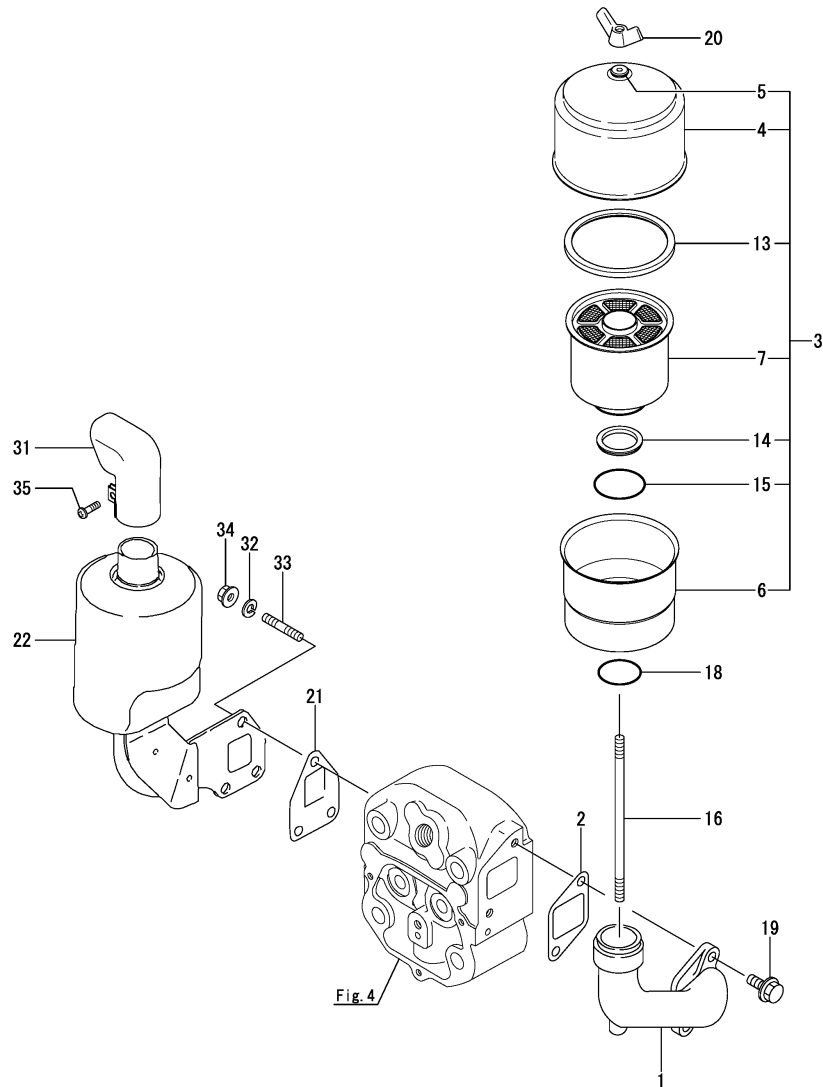

No.	Lev.	Parts No.	Description	Q'ty						I	R
				(A)	(B)	(C)	(D)	(E)	(F)		
1	1	10560H-12020	PIPE, INTAKE	1							
2	1	10550H-12060	PACKING,INLET TUBE	1							
3	1	10560H-12510	CLEANER ASSY, AIR	1							
4	2	10560H-12700	CAP, AIR CLEANER	1							
5	2	10570H-12710	WASHER, SEAL	1							
6	2	10560H-12750	BODY, AIR CLEANER	1							
7	2	10560H-12800	ELEMENT, CLEANER	1							
13	2	10550H-12851	RUBBER, NO1	1							
14	2	10530H-12860	RUBBER, NO2	1							
15	2	24351-350530	PACKING, 35053	1							
16	1	10570H-12551	BOLT	1							
18	1	24321-000450	O-RING, 1AG45.0	1							
19	1	26106-080202	BOLT, M8X 20 PLATED	2							
20	1	26636-080002	NUT, WING M8	1							
21	1	105500-13201	GASKET, SILENCER	1							A
22	1	10560H-13512	SILENCER	1							
31	1	10550H-13570	PIPE, EXHAUST	1							
32	1	22217-080000	WASHER, SPRING 8	3							
33	1	26216-080202	STUD, M8X 20	3							
34	1	26366-080002	NUT, M8	3							
35	1	26557-060202	SCREW, M6X20	1							

Remarks

(A)Gasket kit is shown in Fig.20.



Fig.6. CAMSHAFT

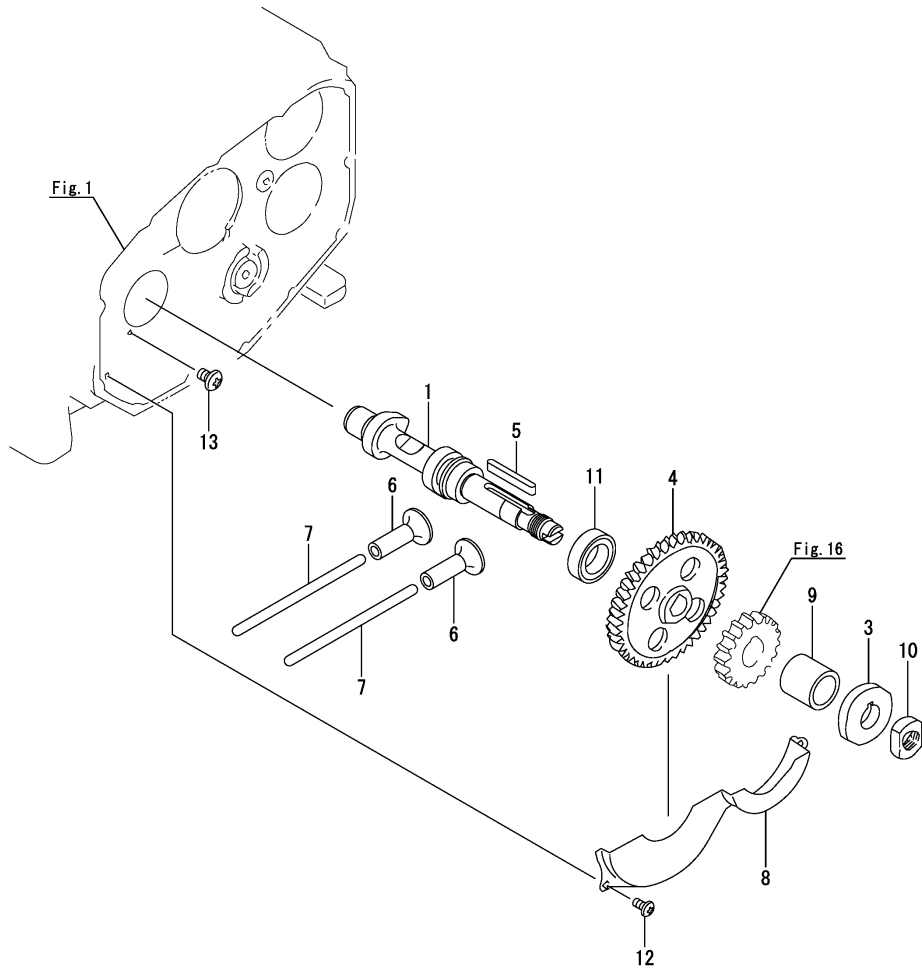

(A)=TF115HM  
(B)=  
(C)=

(D)=  
(E)=  
(F)=

No.	Lev.	Parts No.	Description	Q'ty						I	R
				(A)	(B)	(C)	(D)	(E)	(F)		
1	1	10557H-14010	CAMSHAFT	1							
3	1	10557H-14090	CAM, FUEL	1							
4	1	10560H-14100	GEAR, CAMSHAFT	1							
5	1	10537H-14190	KEY, CAMSHAFT GEAR	1							
6	1	10530H-14200	TAPPET	2							
7	1	10550H-14400	ROD, PUSH	2							
8	1	10550H-14600	COVER	1							
9	1	105300-14700	SPACER	1							
10	1	104300-76460	NUT	1							
11	1	24101-060064	BEARING, BALL 6006	1							
12	1	26022-060122	SCREW, M6X12	3							
13	1	26587-080122	SCREW, M8X12	1							

Fig.7. CRANKSHAFT & FLYWHEEL

(A)=TF115HM  
(B)=  
(C)=

(D)=  
(E)=  
(F)=

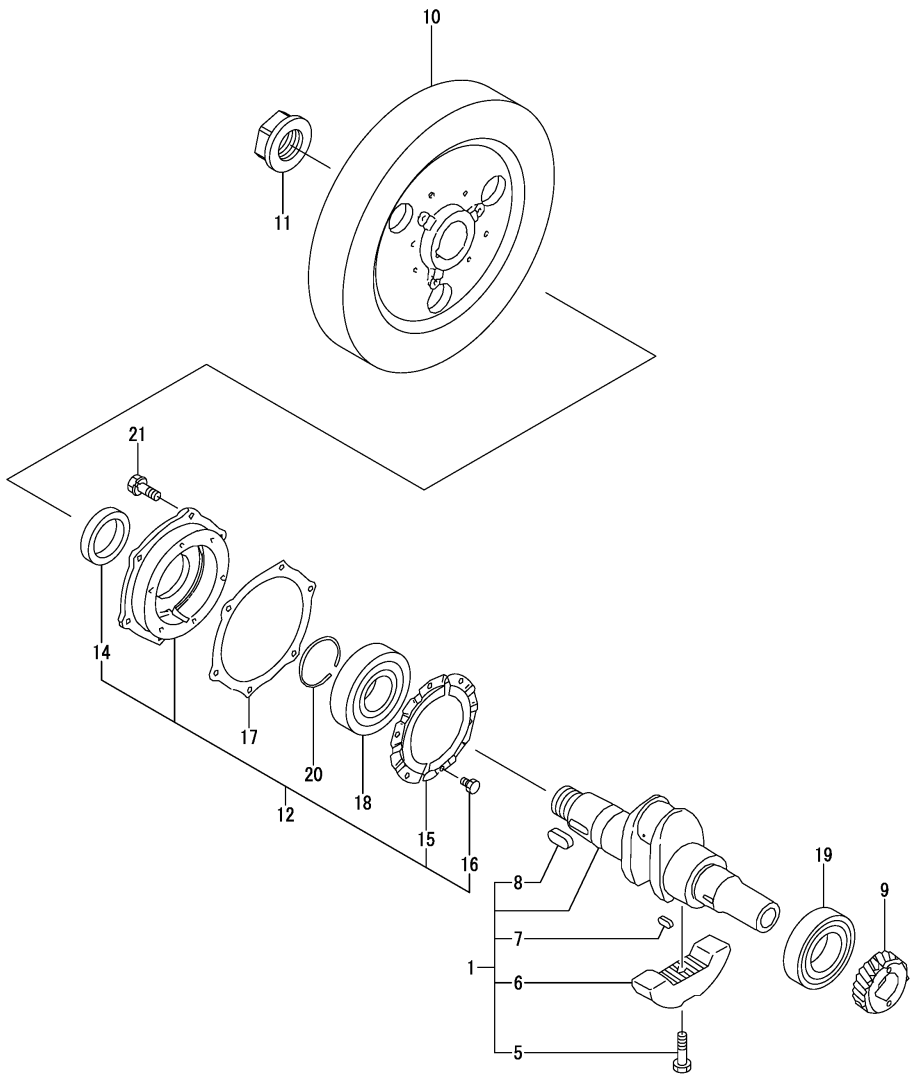

No.	Lev.	Parts No.	Description	Q'ty						I	R
				(A)	(B)	(C)	(D)	(E)	(F)		
1	1	10560H-21700	CRANKSHAFT SUB ASSY	1							
5	2	104271-21100	BOLT, BALANCE WEIGHT	2							
6	2	10550H-21100	WEIGHT, BALANCE	2							
7	2	10557H-21290	KEY, CRANKSHAFT GEAR	1							
8	2	10557H-21520	KEY, FLYWHEEL	1							
9	1	10560H-21200	GEAR, CRANKSHAFT	1							
10	1	10560H-21400	FLYWHEEL	1							
11	1	10550H-21530	NUT, END	1							
12	1	10560H-02500	HOUSING,MAIN METAL S	1							
14	2	10550H-02230	SEAL, OIL CRANKSHAFT	1							
15	2	10550H-02320	RETAINER	2							
16	2	26116-060102	BOLT, M6X 10 PLATED	6							
17	1	105500-02020	GASKET	1							A
18	1	10550H-02300	BEARING, BL310-G,3	1							
19	1	10560H-02310	BEARING, NF309-C3	1							
20	1	22242-000500	RING, 50	1							
21	1	26013-080202	BOLT, M8X 20	7							

Remarks  
(A)Gasket kit is shown in Fig.20.

Fig.8. PISTON & CONNECTING ROD

(A)=TF115HM  
(B)=  
(C)=

(D)=  
(E)=  
(F)=

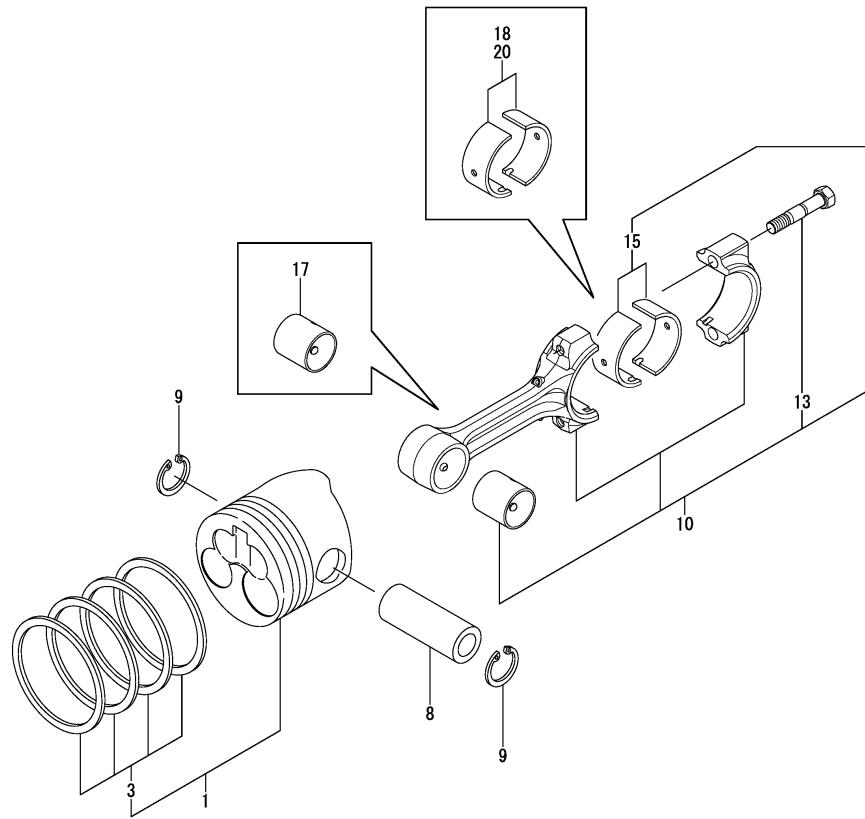

No.	Lev.	Parts No.	Description	Q'ty						I	R
				(A)	(B)	(C)	(D)	(E)	(F)		
1	1	10567H-22092	PISTON ASSY	1							
3	2	10567H-22500	RING SET, PISTON	1							
8	1	105500-22300	PIN, PISTON	1							
9	1	105500-22400	CIRCLIP	2							
10	1	105500-23500	ROD SUB ASSY,CONNECT	1							
13	3	105500-23200	BOLT, CONNECTING ROD	2							
15	2	705500-23600	BEARING, CRANK PIN	1							
17	1	105500-23910	BEARING, PISTON PIN	1							1
18	1	705500-23610	BEARING ASSY, 0.25	1							2
20	1	705500-23620	BEARING, 0.50 US	1							3

Remarks

- (1) Spare parts.
- (2) Under-sized(U.S.=0.25) parts.
- (3) Under-sized(U.S.=0.5) parts.

Fig.9. BALANCER

(A)=TF115HM  
(B)=  
(C)=

(D)=  
(E)=  
(F)=

No.	Lev.	Parts No.	Description	Q'ty						I	R
				(A)	(B)	(C)	(D)	(E)	(F)		
1	1	105500-28251	SHAFT, BALANCER	2							
3	1	10560G-28300	GEAR, BALANCER	1							
4	1	10560G-28310	GEAR, BALANCER	1							
5	1	105500-28380	SPACER	2							
6	1	10560H-28410	GEAR, BALANCER	1							
7	1	105300-28450	RETAINER	1							
8	1	105300-28700	SHAFT	1							
9	1	10550G-28750	GEAR ASSY	1							
10	2	105430-28720	BUSH, IDLE GEAR	1							
12	1	105215-76490	KEY	2							
13	1	123672-83880	RETAINER	1							
14	1	24101-060054	BEARING, BALL 6005	2							
15	1	24101-060094	BEARING, BALL 6009	2							
16	1	26013-060222	BOLT, M6X 22	2							
17	1	26106-080142	BOLT, M8X 14 PLATED	1							
18	1	26106-100552	BOLT, M10X 55 PLATED	1							

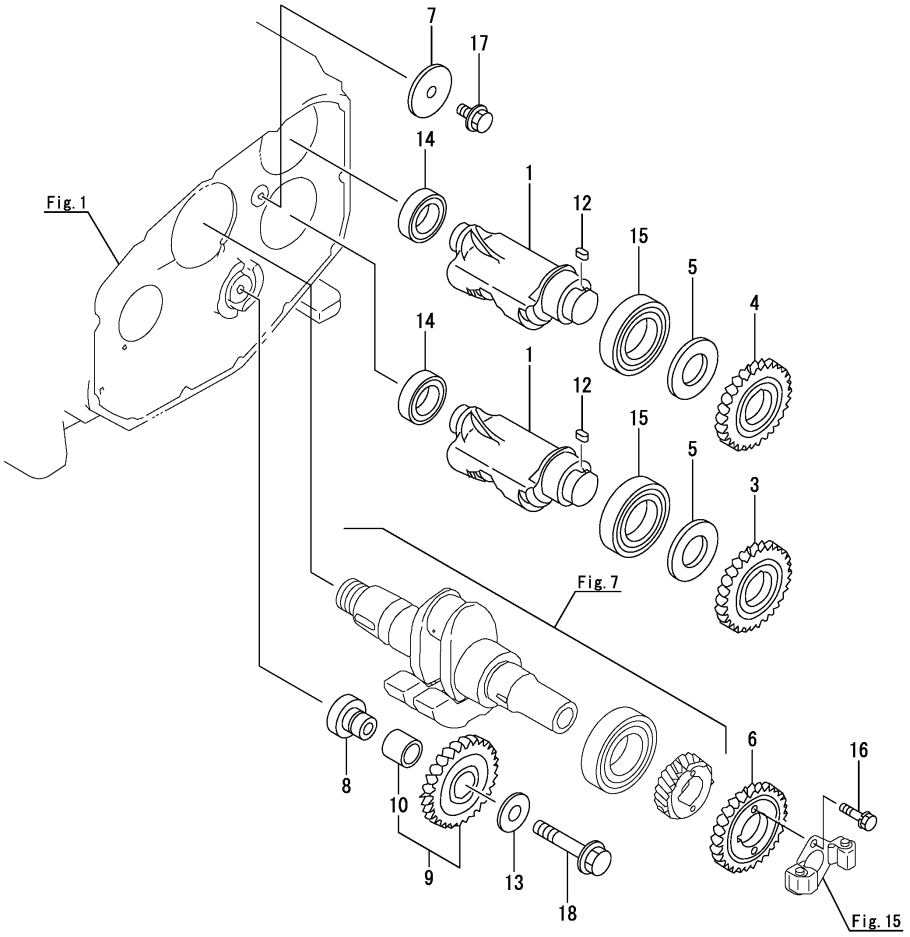

# Fig.10. LUB. OIL SYSTEM

(A)=TF115HM  
(B)=  
(C)=

(D)=  
(E)=  
(F)=

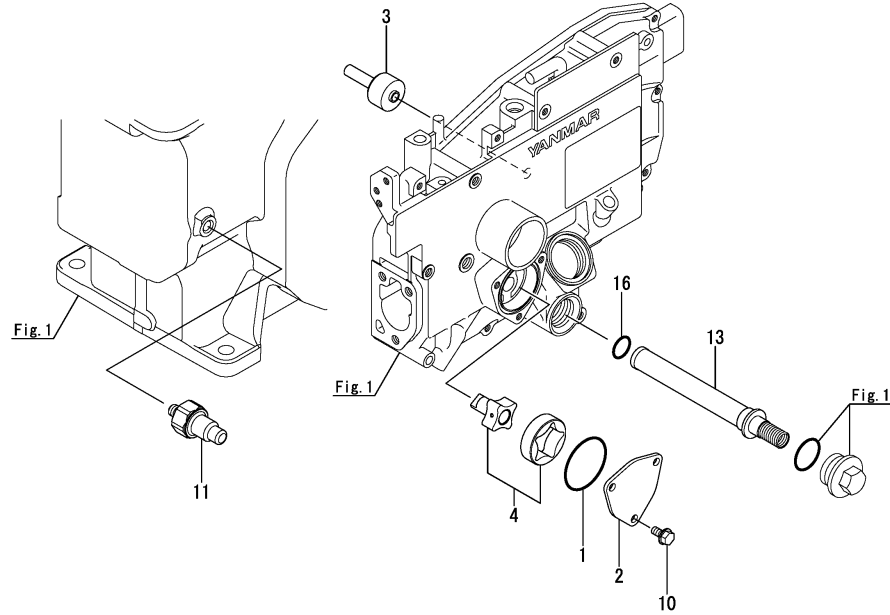

No.	Lev.	Parts No.	Description	Q'ty						I	R
				(A)	(B)	(C)	(D)	(E)	(F)		
1	1	103854-32051	O-RING	1							A
2	1	103854-32082	COVER	1							
3	1	10530H-32200	PIECE	1							
4	1	10537H-32500	PUMP, LUB.OIL CMP	1							
10	1	26106-060122	BOLT, M6X 12 PLATED	3							
11	1	105582-34100	SIGNAL	1							
13	1	105700-35052	STRAINER ASSY, OIL	1							
16	1	24341-000200	O-RING, 1AS20.0	1							A

Remarks

(A)Gasket kit is shown in Fig.20.

Fig.11. HOPPER

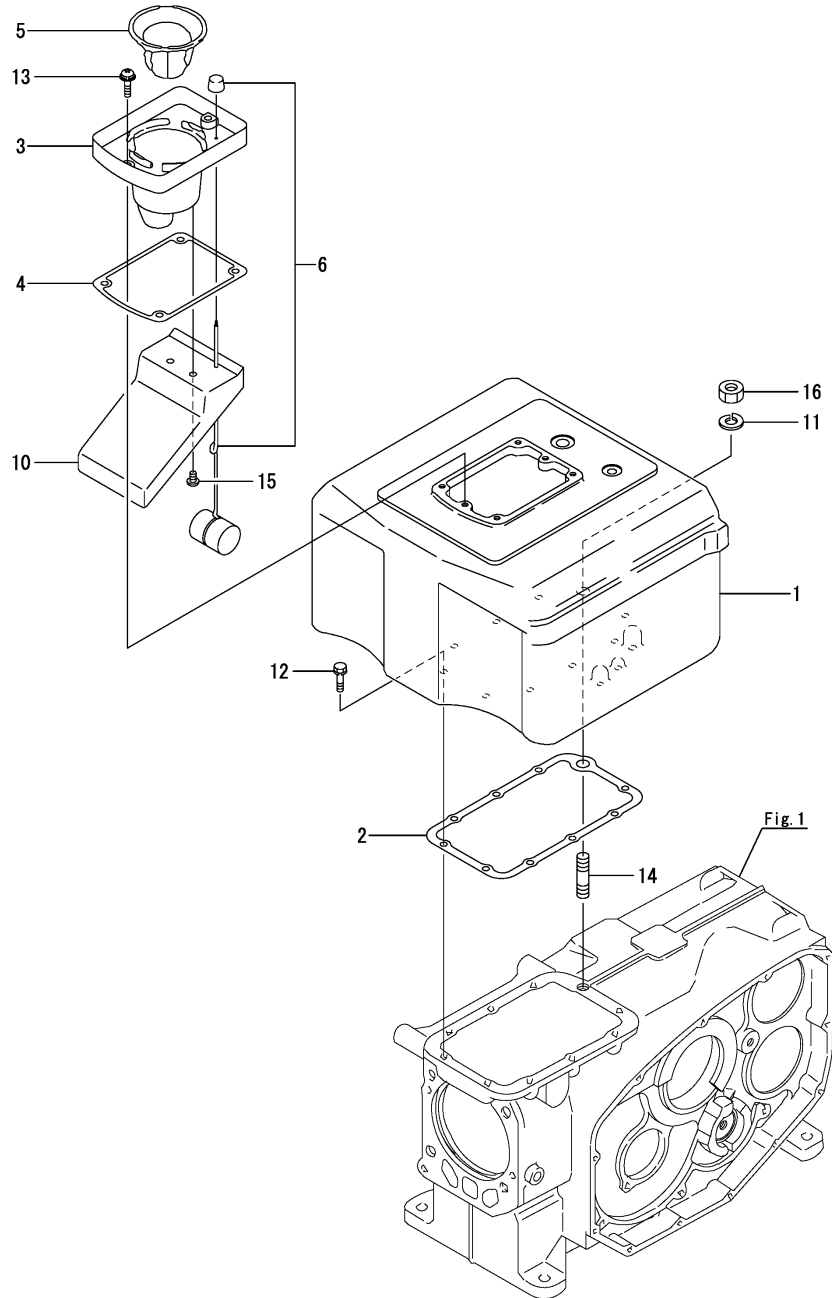

(A)=TF115HM  
(B)=  
(C)=

(D)=  
(E)=  
(F)=

No.	Lev.	Parts No.	Description	Q'ty						I	R
				(A)	(B)	(C)	(D)	(E)	(F)		
1	1	10560H-44020	HOPPER	1							
2	1	10550H-44050	PACKING, HOPPER	1							
3	1	104200-44100	CORE, HOPPER	1							
4	1	10530H-44110	PACKING, SCREEN	1							
5	1	101204-44142	SCREEN	1							
6	1	10530H-44190	FLOAT ASSY	1							
10	1	105306-44280	PLATE, BAFFLE	1							
11	1	22217-120000	WASHER, SPRING 12	1							
12	1	26013-060222	BOLT, M6X 22	9							
13	1	26023-060252	SCREW, M6X25	2							
14	1	26216-120302	STUD, M12X 30	1							
15	1	26557-060102	SCREW, M6X10	2							
16	1	26716-120002	NUT, M12	1							

Fig.12. FUEL INJECTION PUMP

(A)=TF115HM  
(B)=  
(C)=

(D)=  
(E)=  
(F)=

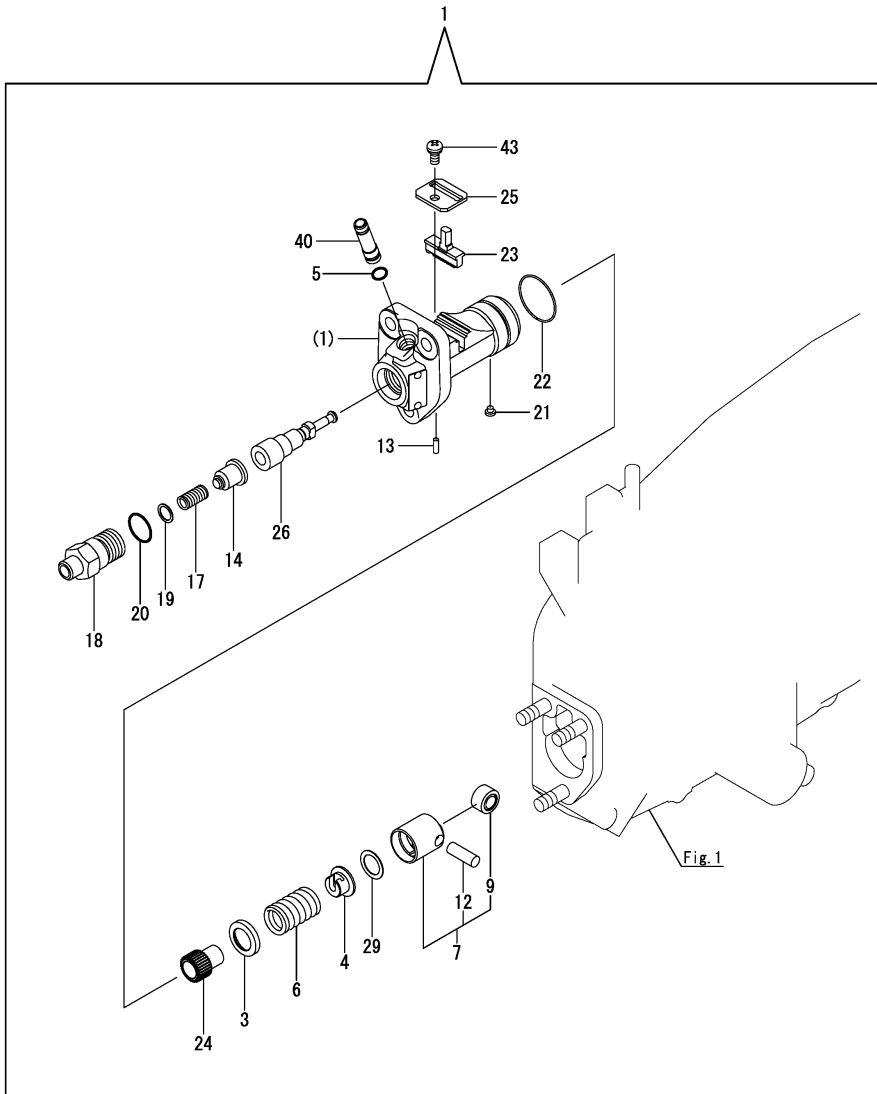

No.	Lev.	Parts No.	Description	Q'ty						I	R
				(A)	(B)	(C)	(D)	(E)	(F)		
1	1	70567H-51201	PUMP ASSY, INJECTION	1							
3	2	158600-51170	RETAINER, SPRING	1							
4	2	174307-51181	RETAINER, SPRING B	1							
5	2	114250-51190	O-RING, S27	1							
6	2	124950-51190	SPRING, PLUNGER	1							
7	2	724550-51520	GUIDE, PLUNGER	1							
9	3	711100-51540	ROLLER ASSY	1							
12	3	174100-54120	PIN, TAPPET ROLLER	1							
13	2	103854-51251	PIN, PLUNGER	1							
14	2	105470-51300	VALVE ASSY, DELIVERY	1							
17	2	124550-51320	SPRING, DELIVERY	1							
18	2	124550-51341	HOLDER, DELIVERY L43	1							
19	2	124550-51350	GASKET, DELIVERY	1							A
20	2	124550-51370	O-RING	1							A
21	2	104271-51450	PIECE, GUIDE	1							
22	2	104271-51460	CIRCLIP	1							
23	2	105300-51500	RACK, CONTROL	1							
24	2	105300-51510	PINION	1							
25	2	105300-51550	RETAINER, RACK	1							
26	2	105570-51602	PLUNGER ASSY	1							
29	2	174307-51700	SHIM SET, PLUNGER	1							
40	2	105300-51800	JOINT	1							
43	2	26022-050102	SCREW, M5X10	1							

Remarks

(A)Gasket kit is shown in Fig.20.

Fig.13. FUEL INJECTION DEVICE

(A)=TF115HM  
(B)=  
(C)=

(D)=  
(E)=  
(F)=

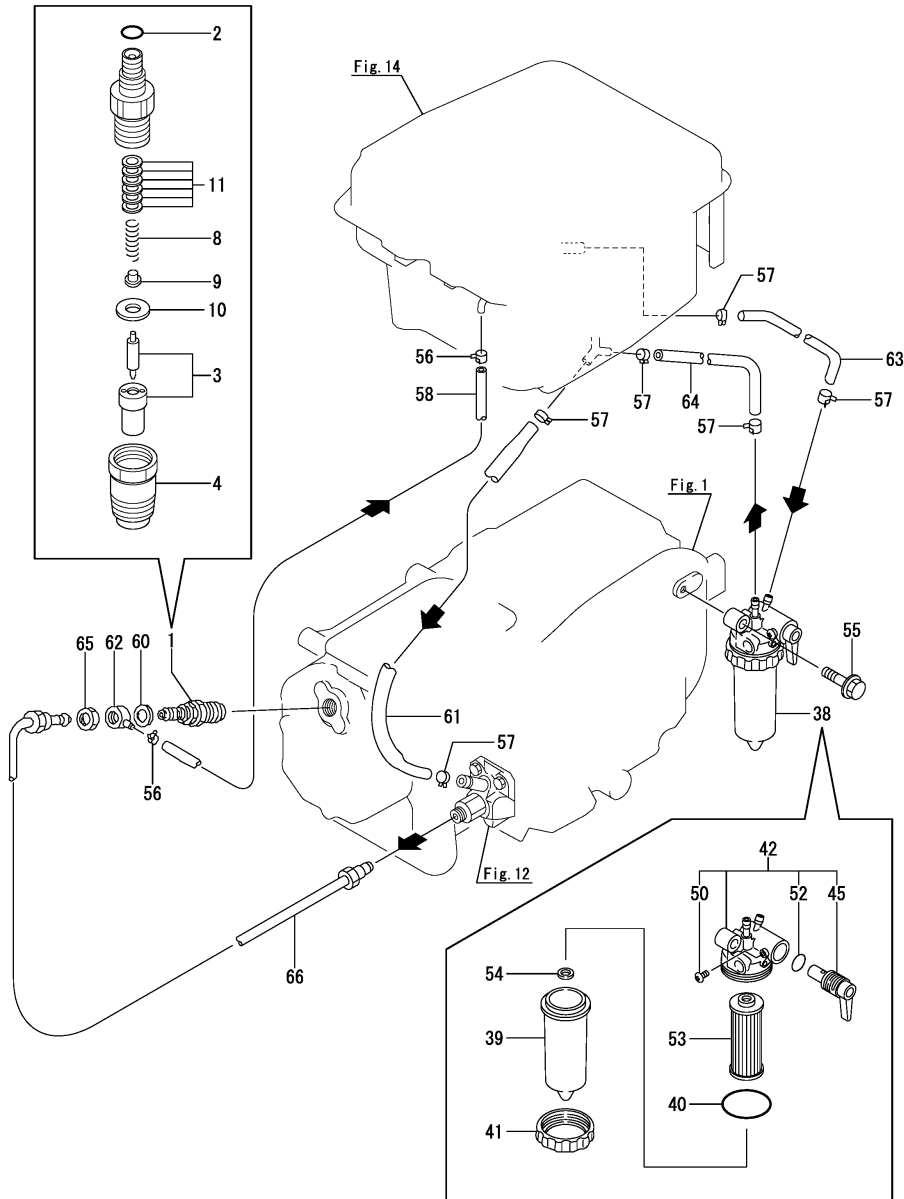

No.	Lev.	Parts No.	Description	Q'ty						I	R
				(A)	(B)	(C)	(D)	(E)	(F)		
1	1	719255-53100	FUEL INJECTOR ASSY	1							
2	2	158552-51930	O-RING, 4D S10	1							
3	2	119620-53001	VALVE ASSY,INJECTION	1							
4	2	119620-53080	NUT, NOZZLE	1							
8	2	119620-53120	SPRING, NOZZLE	1							
9	2	114250-53130	SEAT, SPRING	1							
10	2	119620-53140	SPACER, VALVE STOP	1							
11	2	119803-53400	SHIM SET	1							
38	1	105198-55600	STRAINER ASSY, FUEL	1							
39	2	105198-55510	CUP, STRAINER	1							
40	2	105300-55520	O-RING	1							A
41	2	105300-55610	RING, RETAINING	1							
42	2	105300-55700	BODY ASSY, STRAINER	1							
45	3	105300-55340	LEVER	1							
50	3	104200-55750	SCREW, PAN M4	1							
52	3	24311-000160	O-RING, 1AP16.0	1							
53	2	105370-55711	ELEMENT	1							
54	2	105300-55750	FLOAT	1							
55	1	26106-080302	BOLT, M8X 30 PLATED	1							
56	1	124722-59050	CLAMP, HOSE 9	2							
57	1	124766-59050	CLAMP, HOSE 11.5	6							
58	1	105500-59100	PIPE, FUEL RETURN	1							
60	1	10547H-59500	GASKET	1							
61	1	10550H-59510	PIPE, FUEL OIL	1							
62	1	10537H-59520	JOINT, OVER FLOW	1							
63	1	10550H-59560	PIPE, FUEL OIL	1							
64	1	10550H-59570	PIPE, FUEL OIL	1							
65	1	119620-59700	NUT, NOZZLE	1							
66	1	10567H-59801	PIPE ASSY, INJECTION	1							

Remarks

(A)Gasket kit is shown in Fig.20.



Fig.14. FUEL TANK

(A)=TF115HM  
(B)=  
(C)=

(D)=  
(E)=  
(F)=

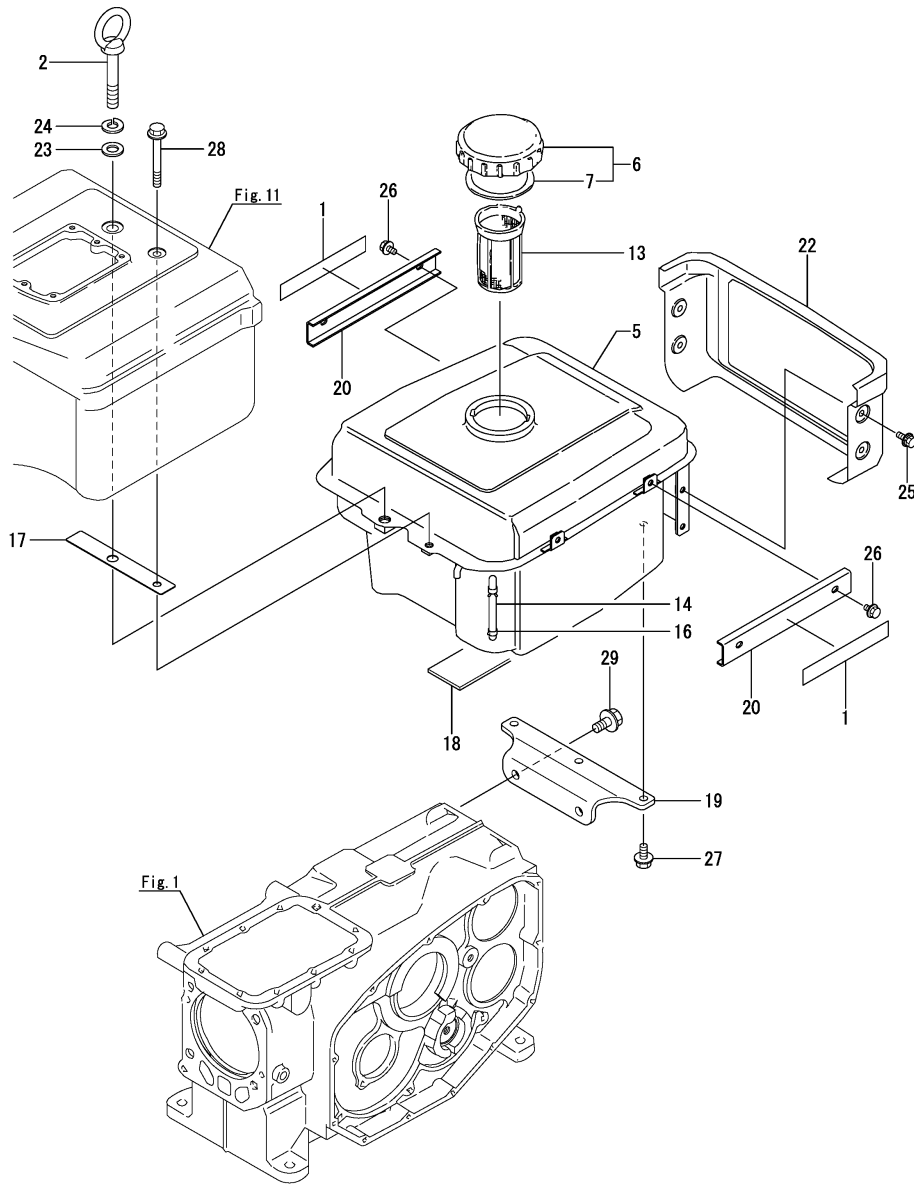

No.	Lev.	Parts No.	Description	Q'ty						I	R
				(A)	(B)	(C)	(D)	(E)	(F)		
1	1	10567H-07260	LABEL, ENGINE MODEL	2							
2	1	105506-07950	BOLT ASSY	1							
5	1	10560H-55020	TANK, FUEL OIL	1							
6	1	10547H-55040	CAP, FUEL TANK	1							
7	2	10530H-55050	GASKET	1							A
13	1	101504-55101	STRAINER, FUEL	1							
14	1	104300-55160	GAUGE, LEVEL	1							
16	1	103854-55220	RETAINER	2							
17	1	10550H-55030	STAY, REINFORCEMENT	1							
18	1	104700-55220	FELT, FUEL TANK	1							
19	1	10560H-55240	STAY, FUEL TANK	1							
20	1	10567H-55240	GUARD, LINE	2							
22	1	10550H-55820	COVER, FRONT	1							
23	1	22137-120000	WASHER, 12	1							
24	1	22217-120000	WASHER, SPRING 12	1							
25	1	26014-060142	BOLT, M6X 14	4							
26	1	26106-060102	BOLT, M6X 10 PLATED	4							
27	1	26106-080162	BOLT, M8X 16 PLATED	3							
28	1	26106-080702	BOLT, M8X 70 PLATED	1							
29	1	26106-100202	BOLT, M10X 20 PLATED	2							

Remarks

(A)Gasket kit is shown in Fig.20.

Fig.15. GOVERNOR & CONTROL EQUIPMENT

(A)=TF115HM

(B)=

(C)=

(D)=

(E)=

(F)=

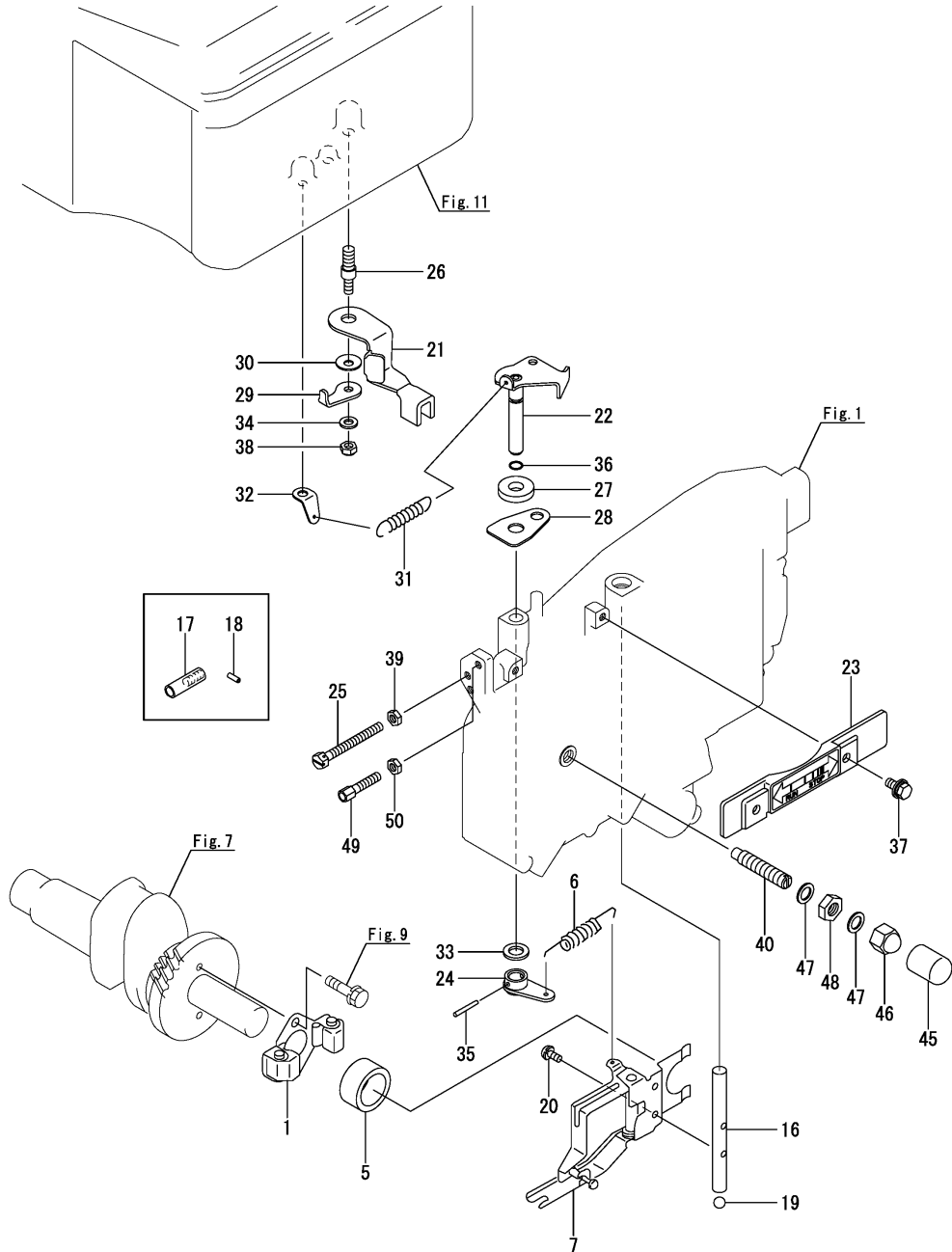

No.	Lev.	Parts No.	Description	Qty						I	R
				(A)	(B)	(C)	(D)	(E)	(F)		
1	1	705300-61701	GOVERNOR ASSY	1							
5	1	10530H-61600	SLEEVE, GOVERNOR	1							
6	1	10540H-66010	SPRING, REGULATOR	1							
7	1	105500-66310	LEVER ASSY, GOVERNOR	1							
16	1	105300-66400	SHAFT	1							
17	1	10550H-66540	SCREW	1							
18	1	22351-030010	PIN, SPRING 3.0X10	1							
19	1	24190-120001	BALL, STEEL 3/8	1							
20	1	26022-050102	SCREW, M5X10	2							
21	1	10530H-66050	HANDLE, REGULATOR	1							
22	1	10530H-66060	ACCELERATOR LEVER	1							
23	1	10530H-66110	COVER, HANDLE	1							
24	1	105215-66200	LEVER, REGULATOR	1							
25	1	105300-66520	SCREW	1							
26	1	10530H-66520	SHAFT, REGURATOR	1							
27	1	10530H-66830	PLATE, FRICTION	1							
28	1	10530H-66850	RETAINER	1							
29	1	10530H-66860	WASHER	1							
30	1	10540H-66880	SPRING	1							
31	1	105840-67300	SPRING, RETURN	1							
32	1	104104-67330	SUPPORT, SPRING	1							
33	1	22117-100000	WASHER, 10	1							
34	1	22137-060000	WASHER, 6	1							
35	1	22322-030220	PIN, TAPER 3X22	1							
36	1	24311-000070	O-RING, 1AP7.0	1							
37	1	26014-060142	BOLT, M6X 14	2							
38	1	26347-060002	NUT, M6	1							
39	1	26756-060002	NUT, LOCK M6	1							
40	1	105300-66551	LIMITER ASSY, FUEL	1							
45	1	10530H-66610	CAP (F.O. LIMITER	1							
46	1	124060-66950	NUT, CAP M10	1							
47	1	22190-100002	WASHER, SEAL 10	2							
48	1	26796-100002	NUT, LOCK M10	1							
49	1	102100-67080	BOLT, ADJUST	1							
50	1	26756-060002	NUT, LOCK M6	1							

# Fig.16. STARTING DEVICE

(A)=TF115HM  
(B)=  
(C)=

(D)=  
(E)=  
(F)=

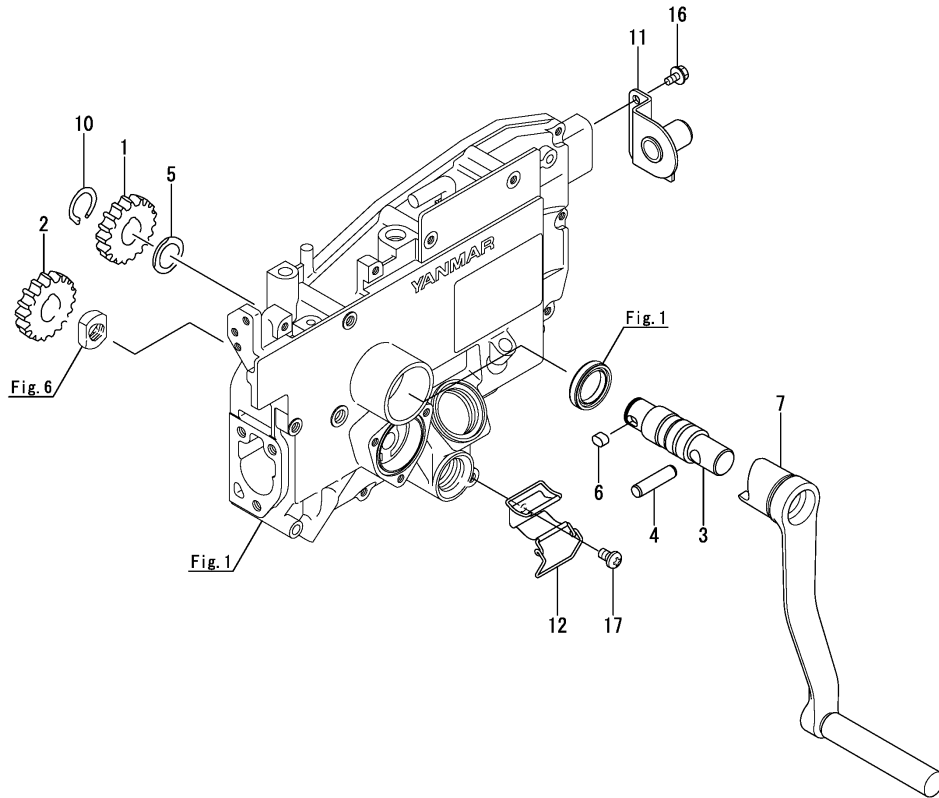

No.	Lev.	Parts No.	Description	Q'ty						I	R
				(A)	(B)	(C)	(D)	(E)	(F)		
1	1	10530G-76330	GEAR, STARTING	1							
2	1	10530G-76330	GEAR, STARTING	1							
3	1	10570H-76340	SHAFT, STARTING	1							
4	1	10570H-76480	PIN, STARTING SHAFT	1							
5	1	105300-76470	COLLAR	1							
6	1	105300-76490	KEY, 7X10	1							
7	1	10570H-76790	HANDLE ASSY, START	1							
10	1	22242-000200	RING, 20	1							
11	1	10570H-08101	RETAINER, HANDLE	1							
12	1	10530G-08510	SPRING ASSY	1							
16	1	26106-060122	BOLT, M6X 12 PLATED	2							
17	1	26557-060102	SCREW, M6X10	1							

Fig.17. LABEL

(A)=TF115HM  
(B)=  
(C)=

(D)=  
(E)=  
(F)=

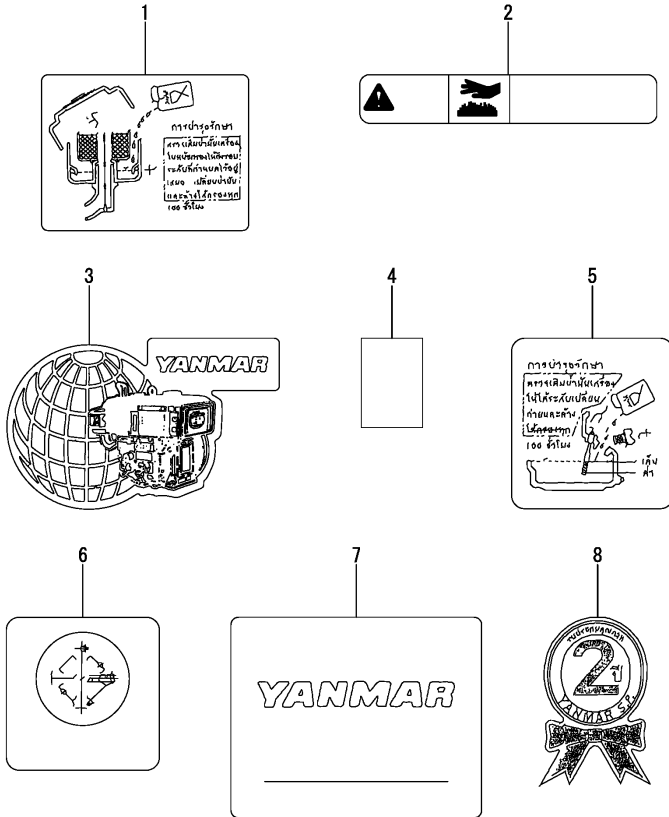

No.	Lev.	Parts No.	Description	Qty						I	R
				(A)	(B)	(C)	(D)	(E)	(F)		
1	1	10540H-07210	LABEL, AIR CLEANER	1							
2	1	10537H-07330	LABEL, CAUTION	1							
3	1	10540H-07621	LABEL, YANMAR WORLD	1							
4	1	10540H-07640	LABEL, F.O.STRAINER	1							
5	1	10540H-07670	LABEL, CAUTION	1							
6	1	10530H-07720	LABEL, TIS MARK	1							
7	1	10530H-07730	LABEL, FRONT	1							
8	1	10530H-07781	LABEL, WARRANTY 2	1							

Fig.18. TOOL

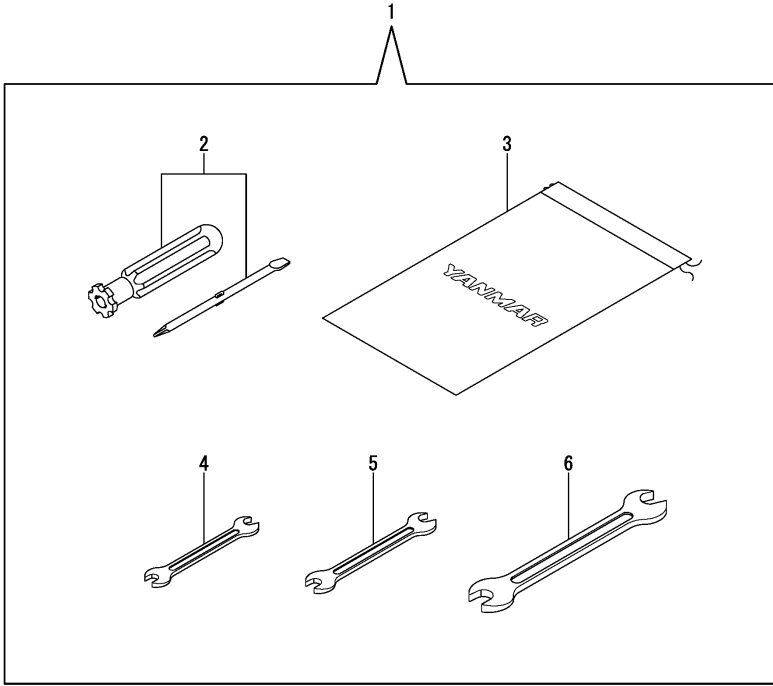

(A)=TF115HM  
(B)=  
(C)=

(D)=  
(E)=  
(F)=

No.	Lev.	Parts No.	Description	Q'ty						I	R
				(A)	(B)	(C)	(D)	(E)	(F)		
1	1	10530H-92100	TOOL SET CMP	1							
2	2	104200-92350	SCREW-DRIVER	1							
3	2	10530G-92600	BAG, TOOL	1							
4	2	28110-100120	SPANNER, 10X12	1							
5	2	28110-140170	SPANNER, 14X17	1							
6	2	28110-190220	SPANNER, 19X22	1							

---

---

---

---

---

---

---

---

---

---

---

---

---

---

---

---

---

---

---

---

---

---

---

---

---

---

---

---

---

---

Fig.19. BUNDLED ITEMS

(A)=TF115HM  
(B)=  
(C)=

(D)=  
(E)=  
(F)=

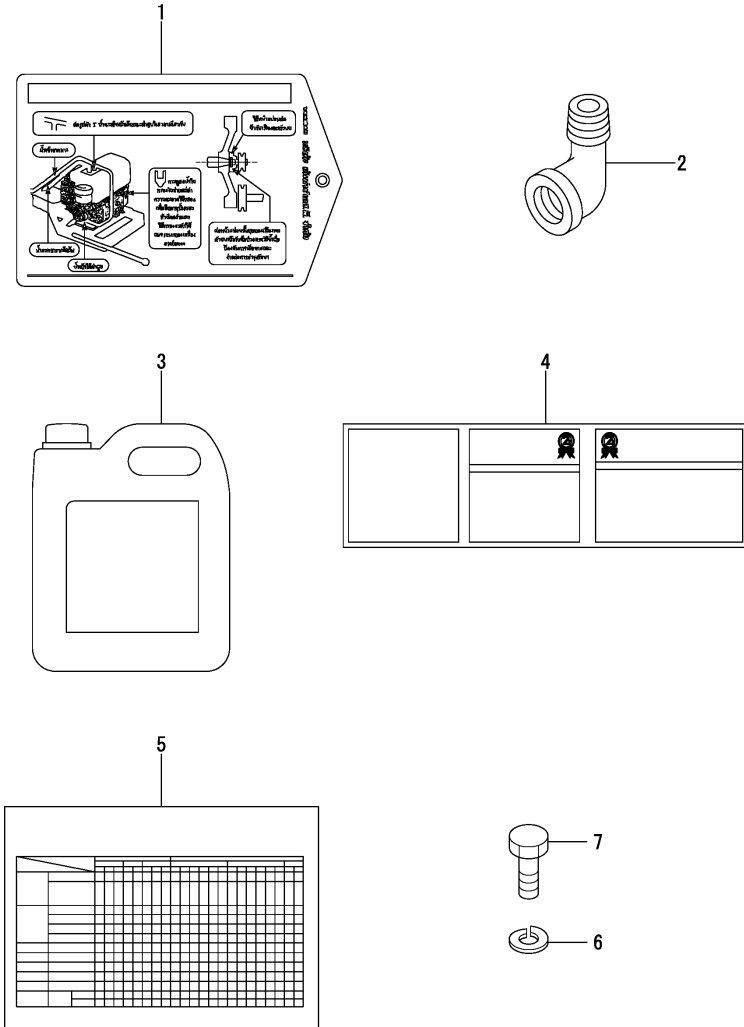

No.	Lev.	Parts No.	Description	Q'ty						I	R
				(A)	(B)	(C)	(D)	(E)	(F)		
1	1	10537H-07201	CARD, INSTRUCTION	1							
2	1	10530H-11930	ELBOW	1							
3	1	10530H-92510	OIL, YANMAR GENUINE	1							
4	1	10547H-95701	CARD, MAINTENANCE	1							
5	1	10537H-97132	CARD, ACCESSORY	1							
6	1	22217-120000	WASHER, SPRING 12	3							
7	1	26206-120352	BOLT, M12X 35 PLATED	3							

Fig.20. GASKET SET(OPTIONAL)

(A)=TF115HM  
(B)=  
(C)=

(D)=  
(E)=  
(F)=

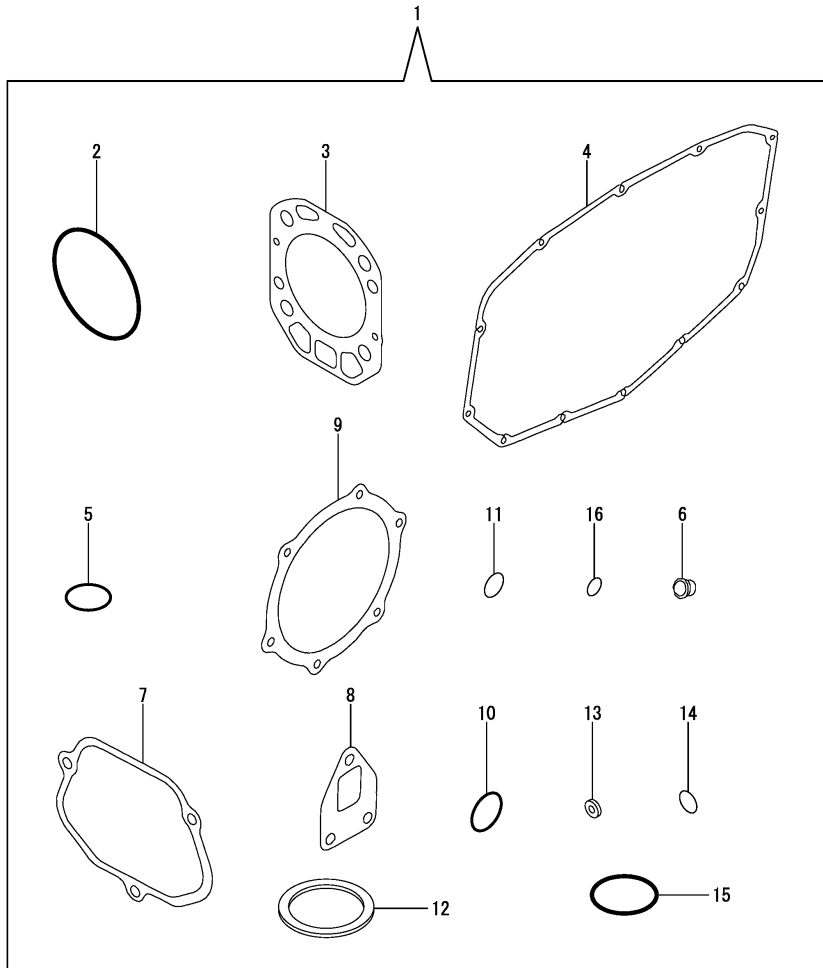

No.	Lev.	Parts No.	Description	Q'ty						I	R
				(A)	(B)	(C)	(D)	(E)	(F)		
1	1	10560H-92600	GASKET SET	1							1
2	2	10550H-01300	O-RING, CYL. LINER	2							
3	2	10557H-01330	GASKET, HEAD	1							
4	2	105500-01410	GASKET	1							
5	2	24311-000320	O-RING, 1AP32.0	1							
6	2	119600-11450	PROTECTOR, NOZZLE	1							
7	2	10550H-11310	GASKET	1							
8	2	105500-13201	GASKET, SILENCER	1							
9	2	105500-02020	GASKET	1							
10	2	103854-32051	O-RING	1							
11	2	24341-000200	O-RING, 1AS20.0	1							
12	2	10530H-55050	GASKET	1							
13	2	124550-51350	GASKET, DELIVERY	1							
14	2	124550-51370	O-RING	1							
15	2	105300-55520	O-RING	1							
16	2	24311-000070	O-RING, 1AP7.0	1							

Remarks

(1)Optional parts.

## Parts No. Index

Parts No.	Fig. No.	Ref. No.
101158-03111	2	4
101158-11230	4	20
		24
101204-44142	11	5
101504-55101	14	13
102100-67080	15	49
103338-01240	1	11
103338-11180	4	11
103854-32051	10	1
	20	10
103854-32082	10	2
103854-51251	12	13
103854-55220	14	16
104104-03750	4	34
104104-67330	15	32
104200-03641	4	36
104200-44100	11	3
104200-55750	13	50
104200-92350	18	2
104271-21100	7	5
104271-51450	12	21
104271-51460	12	22
104300-01220	1	10
104300-08050	3	2
104300-55160	14	14
104300-76460	6	10
104700-55220	14	18
105010-11920	4	26
105100-01660	1	19
105198-55510	13	39
105198-55600	13	38
105215-66200	15	24
105215-76490	9	12
105300-01690	1	28
105300-14700	6	9
105300-28450	9	7
105300-28700	9	8
105300-34040	1	21
105300-51500	12	23
105300-51510	12	24
105300-51550	12	25
105300-51800	12	40
105300-55340	13	45
105300-55520	13	40
	20	15
105300-55610	13	41
105300-55700	13	42
105300-55750	13	54
105300-66400	15	16
105300-66520	15	25

Parts No.	Fig. No.	Ref. No.
105300-66551	15	40
105300-76470	16	5
105300-76490	16	6
105306-44280	11	10
10530G-08510	16	12
10530G-76330	16	1
		2
10530G-92600	18	3
10530H-01800	1	30
10530H-01920	1	31
10530H-01950	1	32
10530H-01960	1	33
10530H-01970	1	34
10530H-03550	4	32
10530H-03610	4	33
10530H-07720	17	6
10530H-07730	17	7
10530H-07781	17	8
10530H-11930	19	2
10530H-12860	5	14
10530H-14200	6	6
10530H-32200	10	3
10530H-34850	1	44
10530H-44110	11	4
10530H-44190	11	6
10530H-55050	14	7
	20	12
10530H-61600	15	5
10530H-66050	15	21
10530H-66060	15	22
10530H-66110	15	23
10530H-66520	15	26
10530H-66610	15	45
10530H-66830	15	27
10530H-66850	15	28
10530H-66860	15	29
10530H-92100	18	1
10530H-92510	19	3
105362-78960	2	5
105370-55711	13	53
10537H-03060	2	2
10537H-07201	19	1
10537H-07330	17	2
10537H-14190	6	5
10537H-32500	10	4
10537H-59520	13	62
10537H-97132	19	5
10540H-01751	1	29
10540H-07210	17	1
10540H-07621	17	3

Parts No.	Fig. No.	Ref. No.
10540H-07640	17	4
10540H-07670	17	5
10540H-66010	15	6
10540H-66880	15	30
105430-28720	9	10
105470-51300	12	14
10547H-55040	14	6
10547H-59500	13	60
10547H-95701	19	4
105500-01200	1	9
105500-01410	1	25
	20	4
105500-02020	7	17
	20	9
105500-03130	2	7
105500-11100	4	8
105500-11111	4	9
105500-11190	4	43
105500-11340	4	15
105500-13201	5	21
	20	8
105500-22300	8	8
105500-22400	8	9
105500-23200	8	13
105500-23500	8	10
105500-23910	8	17
105500-28251	9	1
105500-28380	9	5
105500-59100	13	58
105500-66310	15	7
105506-07950	14	2
10550G-28750	9	9
10550H-01300	1	8
	20	2
10550H-01481	1	26
10550H-01490	1	27
10550H-02230	7	14
10550H-02300	7	18
10550H-02320	7	15
10550H-03070	2	1
10550H-08020	3	1
10550H-11290	4	12
10550H-11310	4	40
	20	7
10550H-11520	4	31
10550H-11650	4	18
10550H-11660	4	22
10550H-12060	5	2
10550H-12851	5	13
10550H-13570	5	31

Parts No.	Fig. No.	Ref. No.
10550H-14400	6	7
10550H-14600	6	8
10550H-21100	7	6
10550H-21530	7	11
10550H-44050	11	2
10550H-55030	14	17
10550H-55820	14	22
10550H-59510	13	61
10550H-59560	13	63
10550H-59570	13	64
10550H-66540	15	17
105570-51602	12	26
10557H-01330	1	12
	20	3
10557H-11120	4	10
10557H-14010	6	1
10557H-14090	6	3
10557H-21290	7	7
10557H-21520	7	8
105582-34100	10	11
105600-01560	1	1
10560G-28300	9	3
10560G-28310	9	4
10560H-01390	1	13
10560H-01900	1	5
10560H-02310	7	19
10560H-02500	7	12
10560H-12020	5	1
10560H-12510	5	3
10560H-12700	5	4
10560H-12750	5	6
10560H-12800	5	7
10560H-13512	5	22
10560H-14100	6	4
10560H-21200	7	9
10560H-21400	7	10
10560H-21700	7	1
10560H-28410	9	6
10560H-44020	11	1
10560H-55020	14	5
10560H-55240	14	19
10560H-92600	20	1
10567H-07260	14	1
10567H-11010	4	1
10567H-22092	8	1
10567H-22500	8	3
10567H-55240	14	20
10567H-59801	13	66
105700-35052	10	13
10570H-08101	16	11



## Parts No. Index

Parts No.	Fig. No.	Ref. No.
10570H-12551	5	16
10570H-12710	5	5
10570H-76340	16	3
10570H-76480	16	4
10570H-76790	16	7
10571H-61250	1	24
105840-67300	15	31
114250-51190	12	5
114250-53130	13	9
119600-11450	4	16
	20	6
119600-11460	4	17
119620-53001	13	3
119620-53080	13	4
119620-53120	13	8
119620-53140	13	10
119620-59700	13	65
119803-53400	13	11
123672-83880	9	13
124060-66950	15	46
124550-51320	12	17
124550-51341	12	18
124550-51350	12	19
	20	13
124550-51370	12	20
	20	14
124722-59050	13	56
124766-59050	13	57
124950-51190	12	6
158552-51930	13	2
158600-51170	12	3
174100-54120	12	12
174307-51181	12	4
174307-51700	12	29
22117-100000	15	33
22137-060000	15	34
22137-120000	14	23
22190-100002	15	47
22217-040000	2	6
22217-080000	5	32
22217-120000	3	3
	11	11
	14	24
	19	6
22242-000200	16	10
22242-000500	7	20
22252-000100	1	22
22312-030180	4	38
22322-030160	4	35
22322-030220	15	35

Parts No.	Fig. No.	Ref. No.
22351-030010	15	18
22351-060012	1	4
	4	20
	4	7
23064-090330	2	8
24101-060054	9	14
24101-060064	6	11
24101-060094	9	15
24190-120001	1	23
	15	19
24311-000060	1	35
24311-000070	4	39
	15	36
	20	16
24311-000160	13	52
24311-000320	1	36
	20	5
24321-000250	1	37
24321-000450	5	18
24341-000200	10	16
	20	11
24351-350530	5	15
26013-060222	9	16
	11	12
26013-080202	7	21
26014-060142	14	25
	15	37
26022-050102	12	43
	15	20
26022-060122	6	12
26023-060252	11	13
26106-060102	14	26
26106-060122	10	10
	16	16
26106-060142	1	38
26106-060202	4	41
26106-060222	2	9
26106-060252	1	39
	2	10
26106-060652	1	40
26106-060702	4	42
26106-080142	9	17
26106-080162	14	27
26106-080202	5	19
26106-080302	13	55
26106-080702	14	28
26106-100202	14	29
26106-100552	9	18
26116-060102	7	16
26206-120352	19	7

Parts No.	Fig. No.	Ref. No.
26216-080202	5	33
26216-080222	1	41
26216-080502	4	27
26216-120302	11	14
26347-060002	15	38
26366-060002	1	42
26366-080002	1	43
	4	28
	5	34
26557-060102	11	15
	16	17
26557-060202	5	35
26587-080122	6	13
26636-080002	5	20
26706-120002	3	4
26716-120002	11	16
26756-060002	15	39
	15	50
26756-080002	4	21
	4	25
26796-100002	15	48
27310-080001	4	29
28110-100120	18	4
28110-140170	18	5
28110-190220	18	6
705300-61701	15	1
705500-23600	8	15
705500-23610	8	18
705500-23620	8	20
70567H-51201	12	1
711100-51540	12	9
719255-53100	13	1
724550-51520	12	7

Parts No.	Fig. No.	Ref. No.
-----------	----------	----------