

0CC50-M00710EN

Introduction

1. This parts catalog is a first edition of the TF120DIL diesel engine.

	Date of issue	Remarks
First edition	Feb., 2016	

2. This parts catalog does not contain the technical data needed for maintenance service.

3. The illustrations used in this parts catalog have been simplified for clarity.

4. The contents of this parts catalog are subject to change without notice.

5. Be sure to use only Yanmar genuine parts for repairs. If imitation parts are used, it may cause engine defects.

Contents

OCC50-M00710

Fig. No. Fig. Name

Fig. No. Fig. Name

TF120DIL

1. CYLINDER BLOCK
2. CYLINDER HEAD & BONNET
3. AIR CLEANER & MUFFLER
4. CAMSHAFT & BALANCER
5. CRANKSHAFT & FLYWHEEL
6. PISTON & CONNECTING ROD
7. LUB. OIL SYSTEM
8. RADIATOR & FUEL TANK
9. FAN
10. FUEL INJECTION PUMP
11. FUEL INJECTION DEVICE
12. GOVERNOR & CONTROL EQUIPMENT
13. LAMP
14. TOOL & LABEL
15. BUNDLED ITEMS
16. GASKET SET(OPTIONAL)

Fig.1. CYLINDER BLOCK

(A)=TF120DIL
(B)=
(C)=

(D)=
(E)=
(F)=

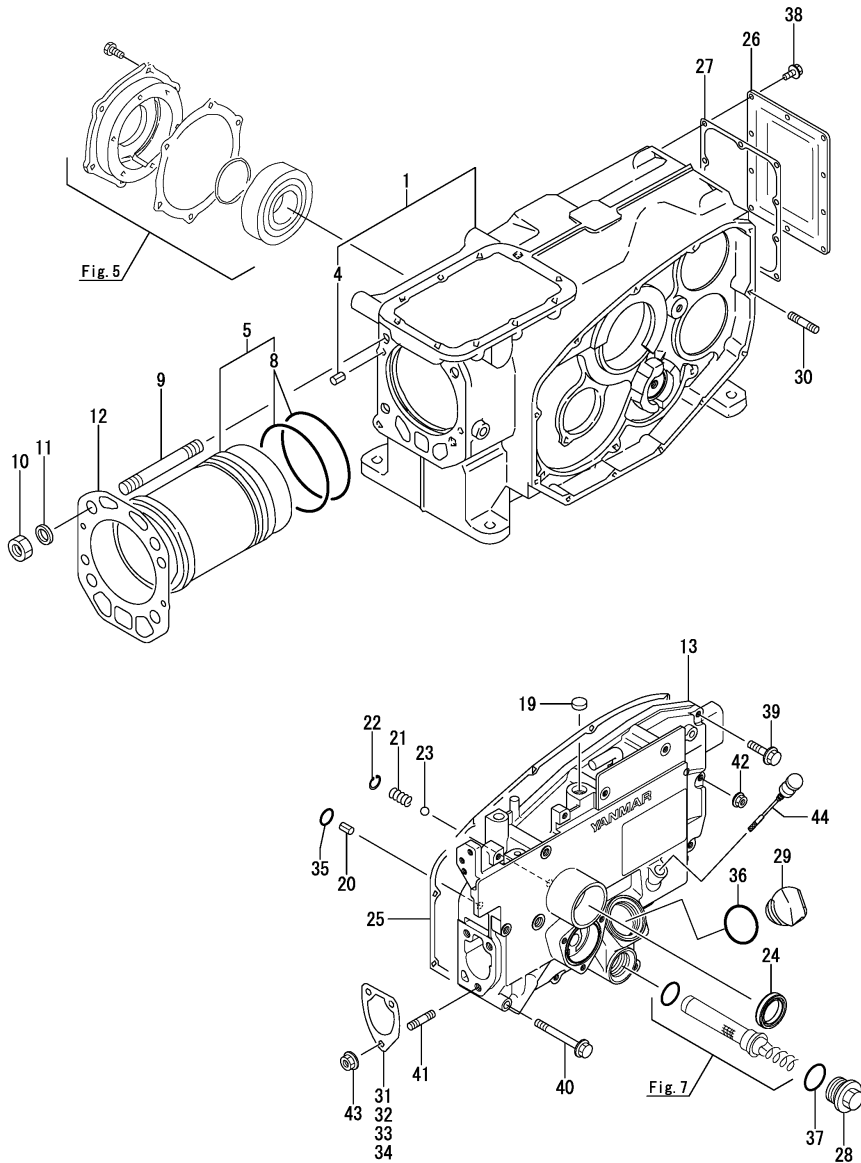

No.	Lev.	Parts No.	Description	Q'ty						I	R
				(A)	(B)	(C)	(D)	(E)	(F)		
1	1	105600-01560	BODY, CYLINDER SUB A	1							
4	2	22351-060012	PIN, SPRING 6.0X12	2							
5	1	10560H-01900	LINER,CYLINDER SUB A	1							
8	2	10550H-01300	O-RING, CYL. LINER	2							A
9	1	105500-01200	BOLT, HEAD	4							
10	1	104300-01220	NUT, CYLINDER HEAD	4							
11	1	103338-01240	WASHER	4							
12	1	105500-01331	GASKET, HEAD	1							A
13	1	10560H-01390	CASE ASSY, GEAR	1							
19	1	105100-01660	PLUG, 14	1							
20	1	22351-060012	PIN, SPRING 6.0X12	1							
21	1	105300-34040	SPRING	1							
22	1	22252-000100	RING, 10	1							
23	1	24190-120001	BALL, STEEL 3/8	1							
24	1	10571H-61250	SEAL,OIL START SHAFT	1							
25	1	105500-01410	GASKET	1							A
26	1	10550H-01481	COVER, REAR	1							
27	1	10550H-01490	GASKET, REAR COVER	1							
28	1	105300-01690	PLUG	1							
29	1	10540H-01751	CAP, FEEDER	1							
30	1	10530H-01800	BOLT	1							
31	1	10530H-01920	SHIM, T=0.3	1							
32	1	10530H-01950	SHIM, T=0.5	1							
33	1	10530H-01960	SHIM, T=0.4	1							
34	1	10530H-01970	SHIM, T=0.6	1							
35	1	24311-000060	O-RING, 1AP6.0	1							
36	1	24311-000320	O-RING, 1AP32.0	1							A
37	1	24321-000250	O-RING, 1AG25.0	1							
38	1	26106-060142	BOLT, M6X 14 PLATED	10							
39	1	26106-060252	BOLT, M6X 25 PLATED	6							
40	1	26106-060652	BOLT, M6X 65 PLATED	6							
41	1	26216-080222	STUD, M8X 22	3							
42	1	26366-060002	NUT, M6	1							
43	1	26366-080002	NUT, M8	3							
44	1	10530H-34850	DIPSTICK, OIL	1							

Remarks

(A)Gasket kit is shown in Fig.16.

Fig.2. CYLINDER HEAD & BONNET

(A)=TF120DIL

(B)=

(C)=

(D)=

(E)=

(F)=

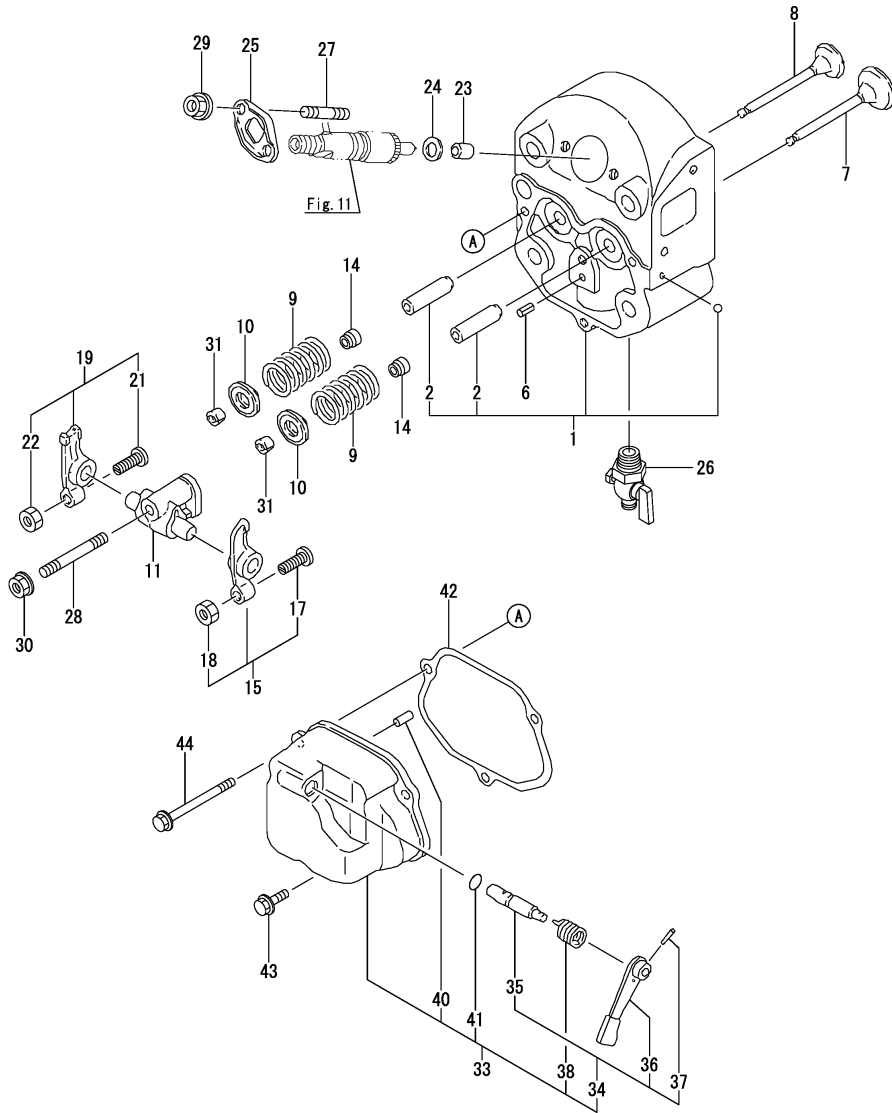

No.	Lev.	Parts No.	Description	Q'ty						I	R
				(A)	(B)	(C)	(D)	(E)	(F)		
1	1	105500-11015	HEAD ASSY, CYLINDER	1							
2	2	105600-11800	GUIDE, VALVE	2							1
6	1	22351-060012	PIN, SPRING 6.0X12	1							
7	1	105500-11100	VALVE, INTAKE	1							
8	1	105500-11111	VALVE, EXHAUST	1							
9	1	10557H-11120	SPRING, VALVE	2							
10	1	103338-11180	RETAINER, SPRING	2							
11	1	10550H-11290	SUPPORT ASSY, ARM	1							
14	1	105500-11340	SEAL, VALVE STEM	2							
15	1	10550H-11650	ARM ASSY, INTAKE	1							
17	2	101158-11230	SCREW, VALVE ADJUST	1							
18	2	26756-080002	NUT, LOCK M8	1							
19	1	10550H-11660	ARM ASSY, EXHAUST	1							
21	2	101158-11230	SCREW, VALVE ADJUST	1							
22	2	26756-080002	NUT, LOCK M8	1							
23	1	119625-11871	PROTECTOR, NOZZLE	1							A
24	1	119625-11880	SEAT, NOZZLE	1							
25	1	10530H-11900	RETAINER, VALVE	1							
26	1	105010-11920	COCK, WATER	1							
27	1	26216-060302	STUD, M6X 30	2							
28	1	26216-080502	STUD, M8X 50	1							
29	1	26366-060002	NUT, M6	2							
30	1	26366-080002	NUT, M8	1							
31	1	27310-080001	COTTER, 8	2							
33	1	10550H-11520	BONNET ASSY	1							
34	2	10530H-03550	LEVER ASSY, DECOMP.	1							
35	3	10530H-03610	SHAFT, DECOMP LEVER	1							
36	3	104104-03750	LEVER, DECOMPRESSION	1							
37	3	22322-030160	PIN, TAPER 3X16	1							
38	2	104200-03641	SPRING, DECOMPRESSION	1							
40	2	22312-030180	PIN, PARALLEL M3X18	1							
41	2	24311-000070	O-RING, 1AP7.0	1							A
42	1	10550H-11310	GASKET	1							A
43	1	26106-060202	BOLT, M6X 20 PLATED	2							
44	1	26106-060702	BOLT, M6X 70 PLATED	1							

Remarks

(1) Spare parts.

(A) Gasket kit is shown in Fig.16.

Fig.3. AIR CLEANER & MUFFLER

(A)=TF120DIL
(B)=
(C)=

(D)=
(E)=
(F)=

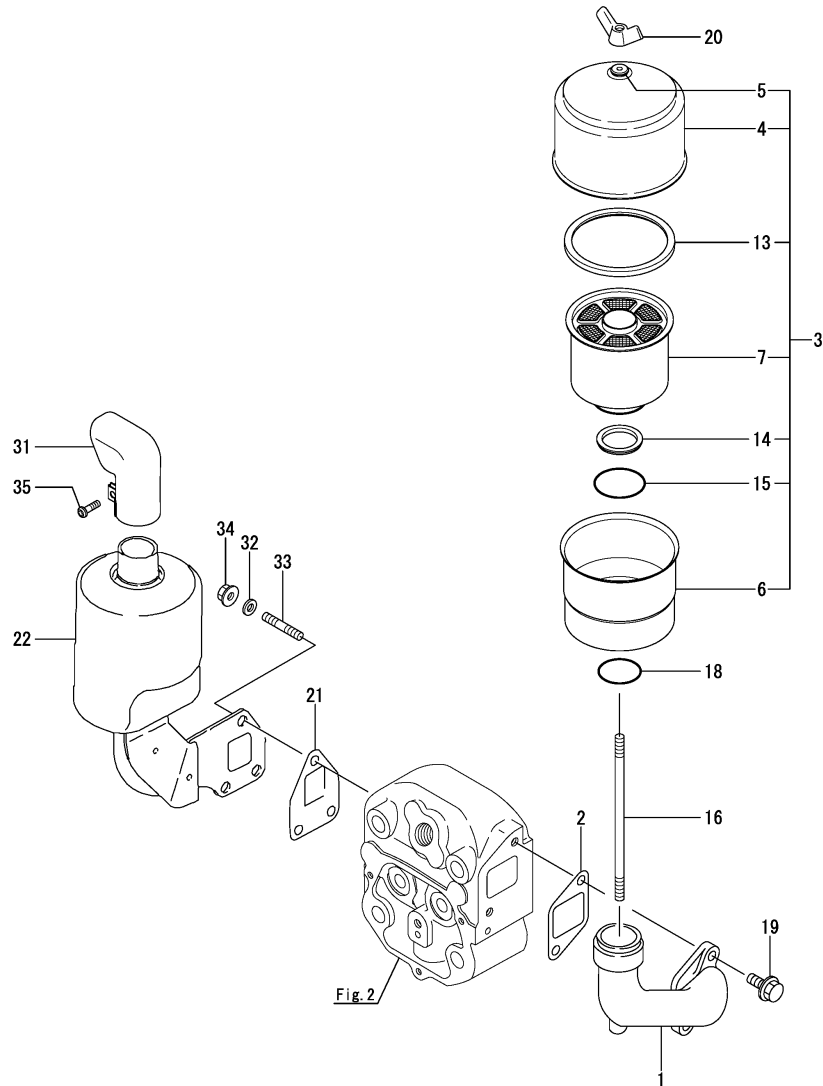

No.	Lev.	Parts No.	Description	Q'ty						I	R
				(A)	(B)	(C)	(D)	(E)	(F)		
1	1	10560H-12030	PIPE, INTAKE	1							
2	1	10550H-12060	PACKING,INLET TUBE	1							
3	1	10560H-12510	CLEANER ASSY, AIR	1							
4	2	10560H-12700	CAP, AIR CLEANER	1							
5	2	10570H-12710	WASHER, SEAL	1							
6	2	10560H-12750	BODY, AIR CLEANER	1							
7	2	10560H-12800	ELEMENT, CLEANER	1							
13	2	10550H-12851	RUBBER, NO1	1							
14	2	10530H-12860	RUBBER, NO2	1							
15	2	24351-350530	PACKING, 35053	1							
16	1	10570H-12551	BOLT	1							
18	1	24321-000450	O-RING, 1AG45.0	1							
19	1	26106-080202	BOLT, M8X 20 PLATED	2							
20	1	26636-080002	NUT, WING M8	1							
21	1	105500-13201	GASKET, SILENCER	1							A
22	1	10560H-13512	SILENCER	1							
31	1	10550H-13570	PIPE, EXHAUST	1							
32	1	22217-080000	WASHER, SPRING 8	3							
33	1	26216-080202	STUD, M8X 20	3							
34	1	26366-080002	NUT, M8	3							
35	1	26557-060202	SCREW, M6X20	1							

Remarks

(A)Gasket kit is shown in Fig.16.

Fig.4. CAMSHAFT & BALANCER

(A)=TF120DIL
(B)=
(C)=

(D)=
(E)=
(F)=

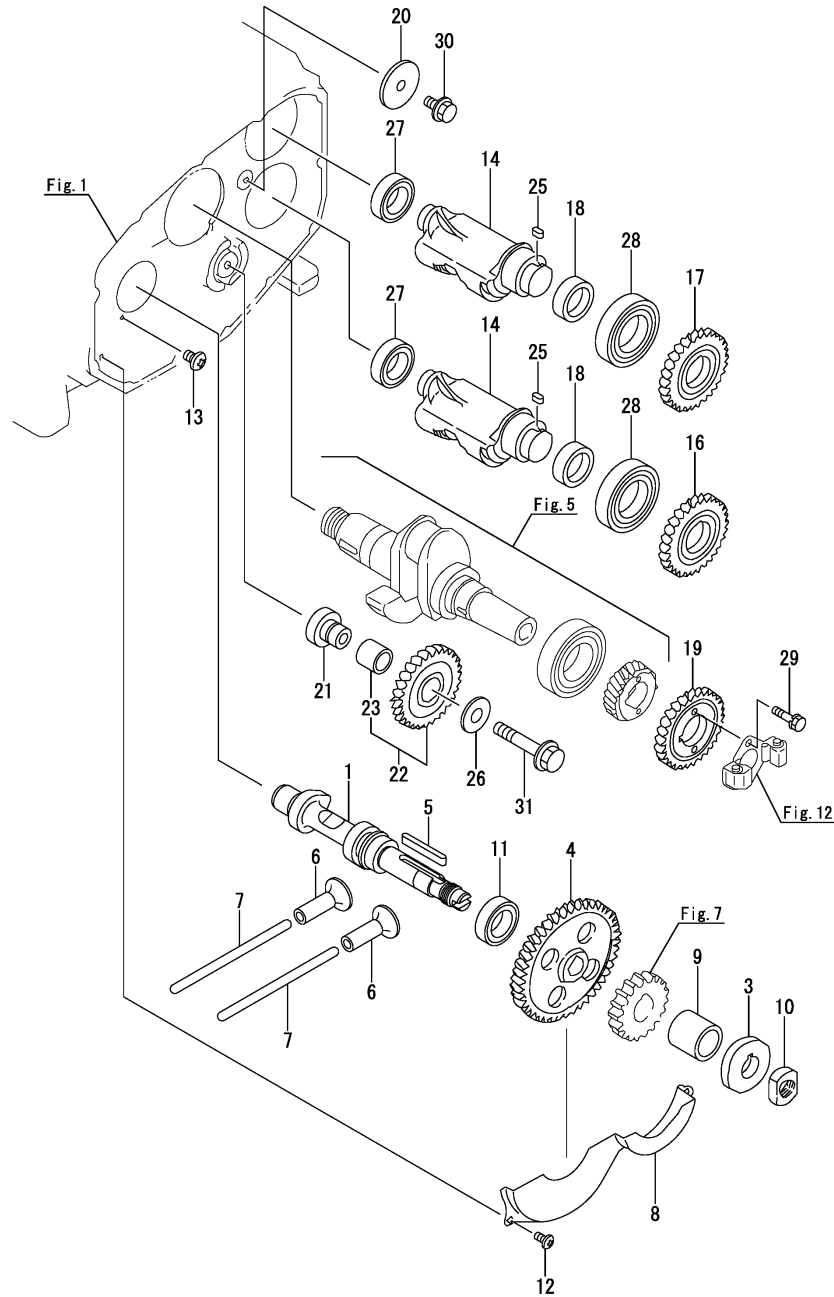

No.	Lev.	Parts No.	Description	Q'ty						I	R
				(A)	(B)	(C)	(D)	(E)	(F)		
1	1	10557H-14010	CAMSHAFT	1							
3	1	105300-14090	CAM, FUEL	1							
4	1	10560H-14100	GEAR, CAMSHAFT	1							
5	1	10537H-14190	KEY, CAMSHAFT GEAR	1							
6	1	10530H-14200	TAPPET	2							
7	1	10555H-14400	ROD, PUSH	2							
8	1	10555H-14600	COVER	1							
9	1	105300-14700	SPACER	1							
10	1	104300-76460	NUT	1							
11	1	24101-060064	BEARING, BALL 6006	1							
12	1	26022-060122	SCREW, M6X12	3							
13	1	26587-080122	SCREW, M8X12	1							
14	1	105500-28251	SHAFT, BALANCER	2							
16	1	10560G-28300	GEAR, BALANCER	1							
17	1	10560G-28310	GEAR, BALANCER	1							
18	1	105500-28380	SPACER	2							
19	1	10560H-28410	GEAR, BALANCER	1							
20	1	105300-28450	RETAINER	1							
21	1	105300-28700	SHAFT	1							
22	1	10550G-28750	GEAR ASSY	1							
23	2	105430-28720	BUSH, IDLE GEAR	1							
25	1	105215-76490	KEY	2							
26	1	123672-83880	RETAINER	1							
27	1	24101-060054	BEARING, BALL 6005	2							
28	1	24101-060094	BEARING, BALL 6009	2							
29	1	26013-060222	BOLT, M6X 22	2							
30	1	26106-080142	BOLT, M8X 14 PLATED	1							
31	1	26106-100552	BOLT, M10X 55 PLATED	1							

Fig.5. CRANKSHAFT & FLYWHEEL

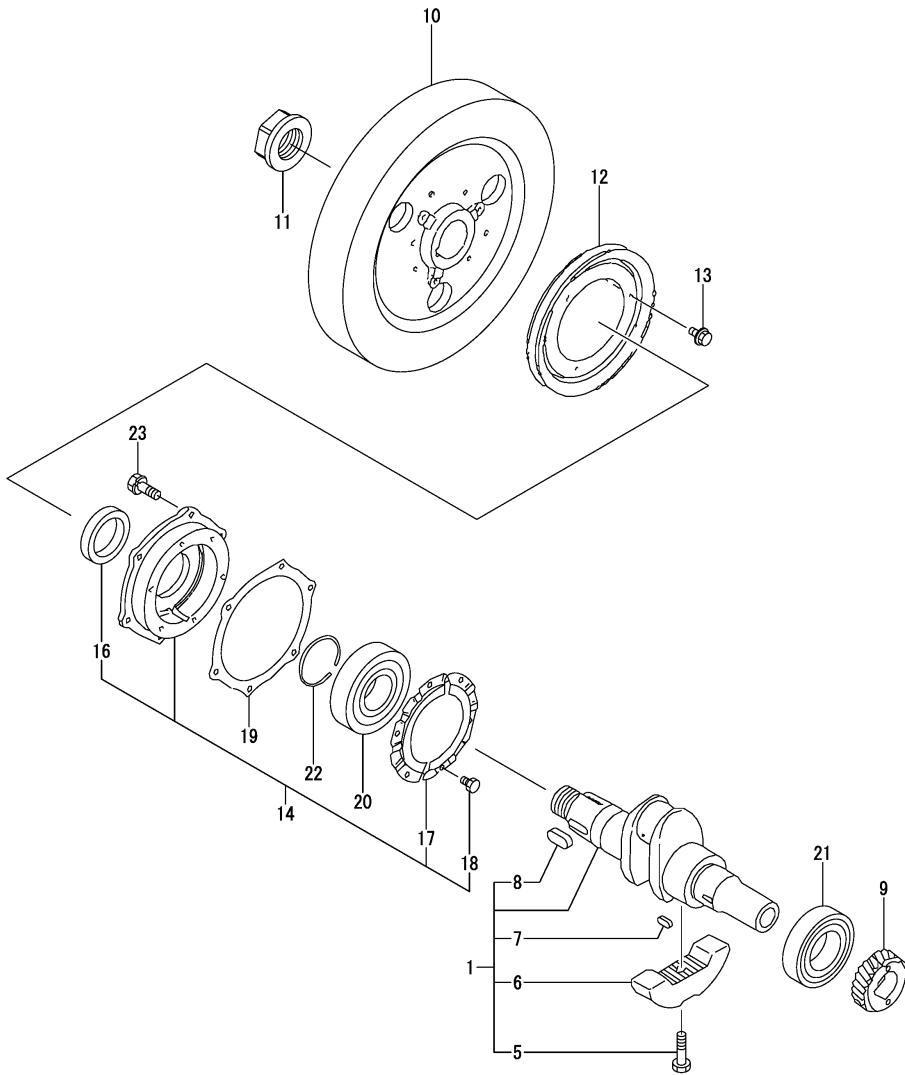

(A)=TF120DIL
(B)=
(C)=

(D)=
(E)=
(F)=

No.	Lev.	Parts No.	Description	Q'ty						I	R
				(A)	(B)	(C)	(D)	(E)	(F)		
1	1	10560H-21700	CRANKSHAFT SUB ASSY	1							
5	2	104271-21100	BOLT, BALANCE WEIGHT	2							
6	2	10550H-21100	WEIGHT, BALANCE	2							
7	2	10557H-21290	KEY, CRANKSHAFT GEAR	1							
8	2	10557H-21520	KEY, FLYWHEEL	1							
9	1	10560H-21200	GEAR, CRANKSHAFT	1							
10	1	10560H-21400	FLYWHEEL	1							
11	1	10550H-21530	NUT, END	1							
12	1	104407-21600	V-PULLEY	1							
13	1	26106-060122	BOLT, M6X 12 PLATED	3							
14	1	10560H-02500	HOUSING,MAIN METAL S	1							
16	2	10550H-02230	SEAL, OIL CRANKSHAFT	1							
17	2	10550H-02320	RETAINER	2							
18	2	26116-060102	BOLT, M6X 10 PLATED	6							
19	1	105500-02020	GASKET	1							A
20	1	10550H-02300	BEARING, BL310-G,3	1							
21	1	10560H-02310	BEARING, NF309-C3	1							
22	1	22242-000500	RING, 50	1							
23	1	26013-080202	BOLT, M8X 20	7							

Remarks

(A)Gasket kit is shown in Fig.16.

Fig.6. PISTON & CONNECTING ROD

(A)=TF120DIL
(B)=
(C)=

(D)=
(E)=
(F)=

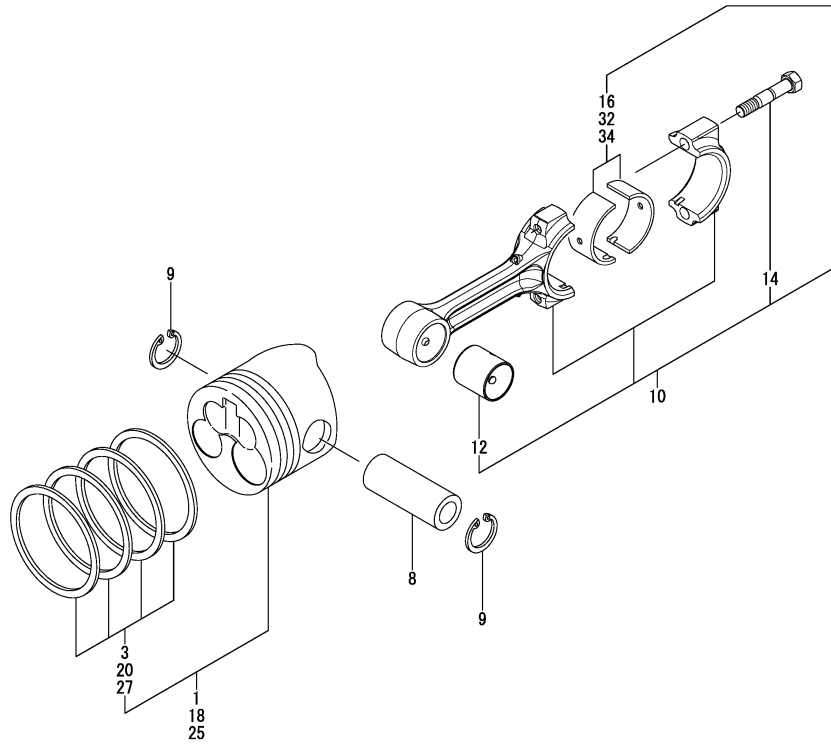

No.	Lev.	Parts No.	Description	Q'ty						I	R
				(A)	(B)	(C)	(D)	(E)	(F)		
1	1	10567H-22190	PISTON ASSY	1							
3	2	10567H-22500	RING SET, PISTON	1							
8	1	105500-22300	PIN, PISTON	1							
9	1	105500-22400	CIRCLIP	2							
10	1	105500-23500	ROD SUB ASSY,CONNECT	1							
12	3	105500-23910	BEARING, PISTON PIN	1							1
14	3	105500-23200	BOLT, CONNECTING ROD	2							
16	2	705500-23600	BEARING, CRANK PIN	1							
18	1	105600-22470	PISTON W/RING .25OS	1							2
20	2	105600-22510	RING SET, 0.25 OS	1							2
25	1	105600-22480	PISTON W/RING .50OS	1							3
27	2	105600-22520	RING SET, 0.50 OS	1							3
32	1	705500-23610	BEARING ASSY, 0.25	1							4
34	1	705500-23620	BEARING, 0.50 US	1							5

Remarks

- (1) Spare parts.
- (2) Over-sized (O.S.=0.25) parts.
- (3) Over-sized (O.S.=0.5) parts.
- (4) Under-sized (U.S.=0.25) parts.
- (5) Under-sized (U.S.=0.5) parts.

Fig.7. LUB. OIL SYSTEM

(A)=TF120DIL
(B)=
(C)=

(D)=
(E)=
(F)=

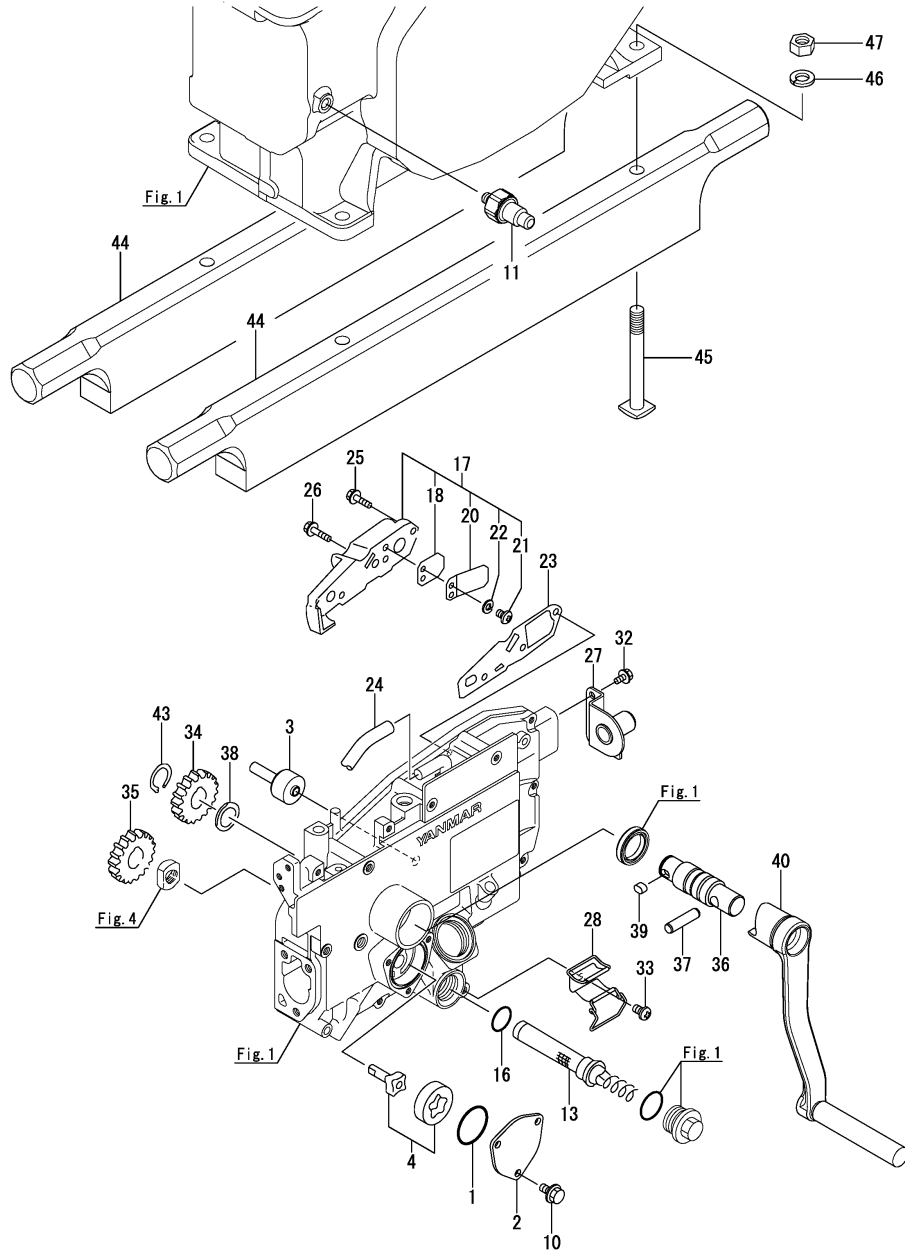

No.	Lev.	Parts No.	Description	Q'ty						I	R
				(A)	(B)	(C)	(D)	(E)	(F)		
1	1	103854-32051	O-RING	1							A
2	1	103854-32082	COVER	1							
3	1	10530H-32200	PIECE	1							
4	1	10537H-32500	PUMP, LUB.OIL CMP	1							
10	1	26106-060122	BOLT, M6X 12 PLATED	3							
11	1	105582-34100	SIGNAL	1							
13	1	105306-35052	STRAINER ASSY, OIL	1							
16	1	24341-000200	O-RING, 1AS20.0	1							A
17	1	10550H-03070	COVER ASSY, BREATHER	1							
18	2	10537H-03060	VALVE, RETURN	1							
20	2	101158-03111	RETAINER	1							
21	2	105362-78960	SCREW, M4X8	2							
22	2	22217-040000	WASHER, SPRING 4	2							
23	1	105500-03130	GASKET, BREATHER	1							
24	1	23064-090330	HOSE, 9 X 330	1							
25	1	26106-060222	BOLT, M6X 22 PLATED	2							
26	1	26106-060252	BOLT, M6X 25 PLATED	1							
27	1	10570H-08101	RETAINER, HANDLE	1							
28	1	10530G-08510	SPRING ASSY	1							
32	1	26106-060122	BOLT, M6X 12 PLATED	2							
33	1	26557-060102	SCREW, M6X10	1							
34	1	10530G-76330	GEAR, STARTING	1							
35	1	10530G-76330	GEAR, STARTING	1							
36	1	10570H-76340	SHAFT, STARTING	1							
37	1	10570H-76480	PIN, STARTING SHAFT	1							
38	1	105300-76470	COLLAR	1							
39	1	105300-76490	KEY, 7X10	1							
40	1	10570H-76790	HANDLE ASSY, START	1							
43	1	22242-000200	RING, 20	1							
44	1	10550H-08020	BED, ENGINE	2							
45	1	104300-08050	BOLT, FOUNDATION	4							
46	1	22217-120000	WASHER, SPRING 12	4							
47	1	26706-120002	NUT, M12	4							

Remarks

(A)Gasket kit is shown in Fig.16.

Fig.8. RADIATOR & FUEL TANK

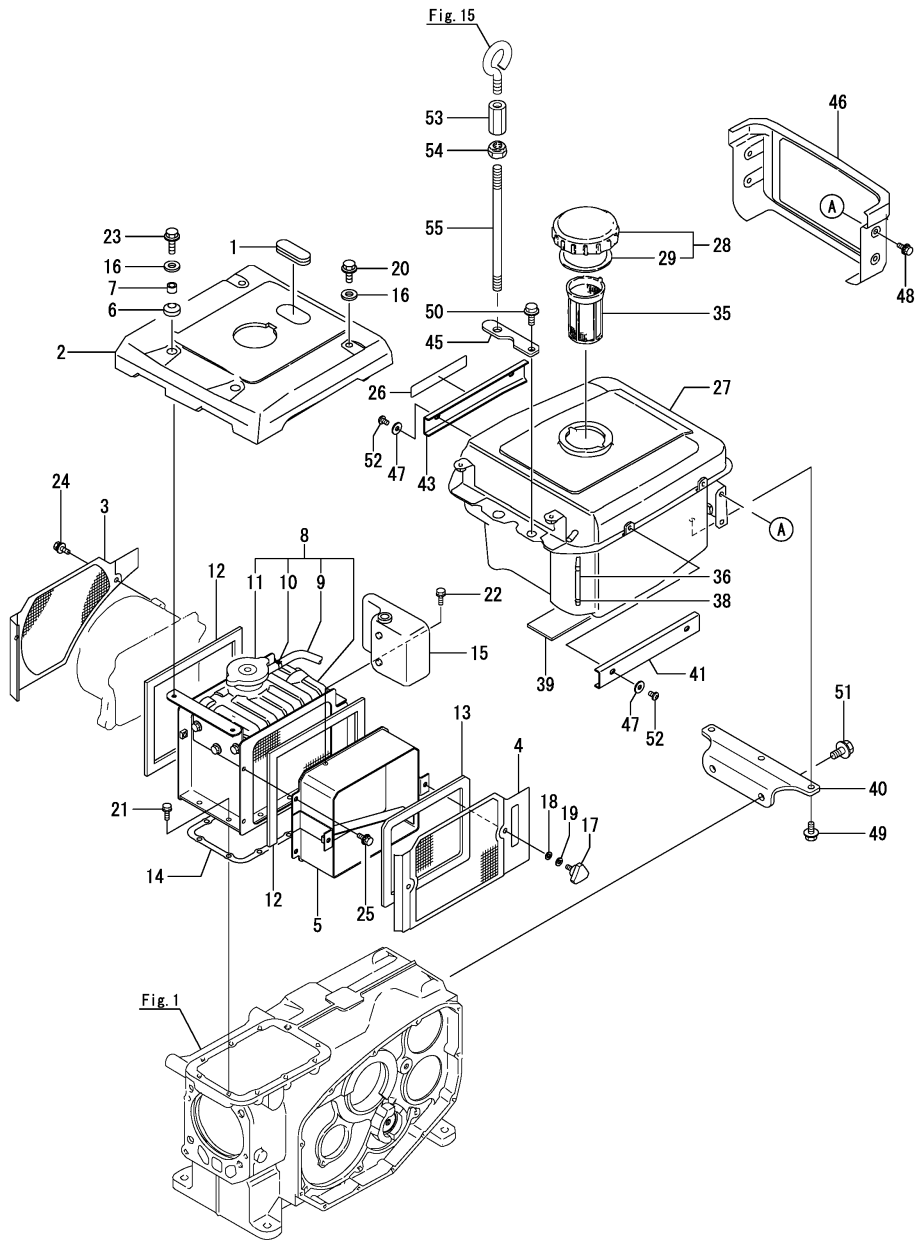

(A)=TF120DIL
(B)=
(C)=

(D)=
(E)=
(F)=

No.	Lev.	Parts No.	Description	Q'ty						I	R
				(A)	(B)	(C)	(D)	(E)	(F)		
1	1	105300-44220	COVER, RADIATOR	1							
2	1	10560H-44250	COVER, RADIATOR	1							
3	1	10560H-44330	SCREEN	1							
4	1	10560H-44340	SCREEN	1							
5	1	10550H-44370	DUCT, SCREEN	1							
6	1	105300-44451	ABSORBER	2							
7	1	105300-44460	COLLAR	2							
8	1	10560H-44501	RADIATOR ASSY	1							
9	2	10530H-44570	PIPE, 7X205	1							
10	2	121250-44590	CLAMP, HOSE	1							
11	2	10530H-44600	CAP, RADIATOR	1							
12	1	104607-44540	SPONGE	2							
13	1	106100-44560	SPONGE, 15X5X1000	1							
14	1	10550H-44611	GASKET, RADIATOR	1							
15	1	10530H-44630	TANK, SUB	1							
16	1	10540H-76940	WASHER	4							
17	1	160725-78350	KNOB, BOLT M6X15	2							
18	1	22117-060000	WASHER, 6	2							
19	1	22217-060000	WASHER, SPRING 6	2							
20	1	26013-060142	BOLT, M6X 14	2							
21	1	26013-060162	BOLT, M6X 16	8							
22	1	26013-060182	BOLT, M6X 18	1							
23	1	26013-060182	BOLT, M6X 18	2							
24	1	26014-060142	BOLT, M6X 14	2							
25	1	26014-060162	BOLT, M6X 16	4							
26	1	10567H-07110	LABEL, ENGINE MODEL	1							
27	1	10560H-55040	TANK, FUEL OIL	1							
28	1	10547H-55050	CAP ASSY, FUEL TANK	1							
29	2	10530H-55050	GASKET	1							A
35	1	101504-55101	STRAINER, FUEL	1							
36	1	104300-55160	GAUGE, LEVEL	1							
38	1	103854-55220	RETAINER	2							
39	1	104700-55220	FELT, FUEL TANK	1							
40	1	10560H-55240	STAY, FUEL TANK	1							
41	1	10567H-55300	GUARD, LINE(OFW	1							
43	1	10567H-55330	GUARD, LINE FW	1							
45	1	10530H-55520	RETAINER	1							
46	1	10550H-55830	COVER, LIGHT	1							
47	1	10540H-76940	WASHER	4							
48	1	26014-060142	BOLT, M6X 14	4							
49	1	26106-080162	BOLT, M8X 16 PLATED	3							
50	1	26106-080222	BOLT, M8X 22 PLATED	1							
51	1	26106-100202	BOLT, M10X 20 PLATED	2							
52	1	26557-060102	SCREW, M6X10	4							
53	1	105500-07910	NUT, M12	1							
54	1	104507-07920	NUT, M12	1							
55	1	10550H-07940	BOLT, ENGINE LIFT	1							

Remarks

(A)Gasket kit is shown in Fig.16.

N:Old $\xrightarrow{\text{Yes}}$ New, Q:Old $\xrightarrow{\text{No}}$ New, R:Old $\xrightarrow{\text{Yes}}$ New, S:Old $\xrightarrow{\text{No}}$ New, W:Add, Z:Discontinued, F:Interchangeable by set, K:Q'ty Change

Fig.9. FAN

(A)=TF120DIL
(B)=
(C)=

(D)=
(E)=
(F)=

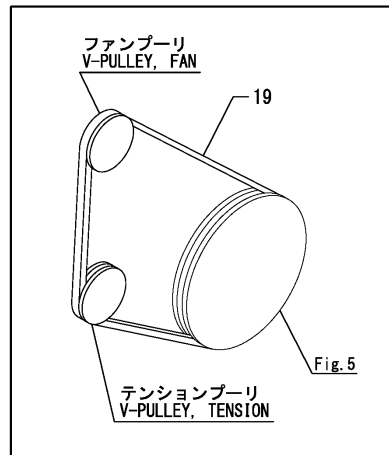
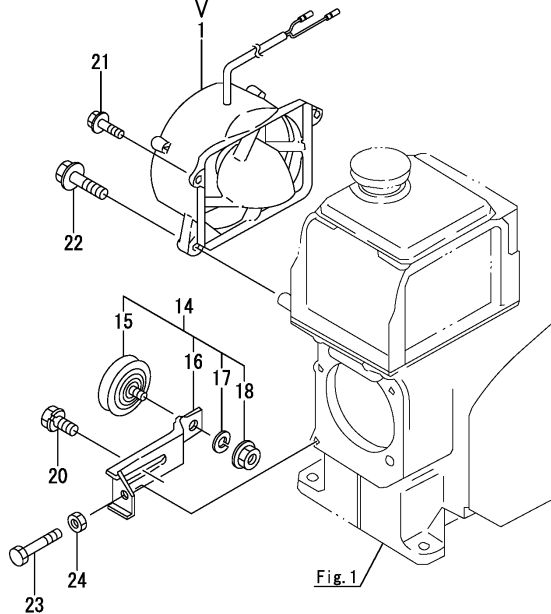
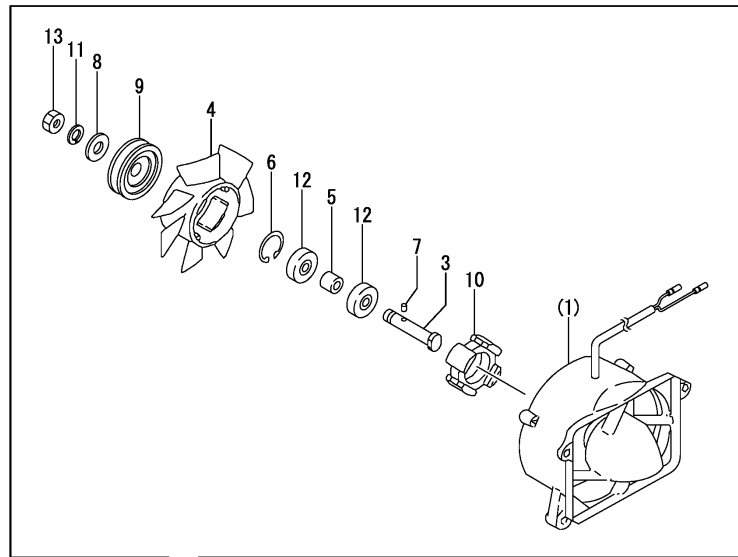

No.	Lev.	Parts No.	Description	Q'ty						I	R
				(A)	(B)	(C)	(D)	(E)	(F)		
1	1	10550H-44210	CASE ASSY, FAN	1							
3	2	105340-44701	SHAFT, FAN	1							
4	2	10550H-44701	FAN	1							
5	2	10530H-44720	COLLAR	1							
6	2	106383-44740	CIRCLIP	1							
7	2	105340-44750	PIN	1							
8	2	10550H-44760	WASHER	1							
9	2	10530H-44780	PULLEY, FAN	1							
10	2	10530H-78010	STATOR ASSY	1							
11	2	22217-120000	WASHER, SPRING 12	1							
12	2	24107-062013	BEARING, 6201ZZP6	2							
13	2	26777-120002	NUT, LOCK M12	1							
14	1	10550H-44830	PULLEY ASSY, TENSION	1							
15	2	10610H-44651	PULLEY, TENSION	1							
16	2	10550H-44950	LEVER, TENSION PULLEY	1							
17	2	22217-080000	WASHER, SPRING 8	1							
18	2	26366-080002	NUT, M8	1							
19	1	25117-003801	V-BELT, M38H	1							
20	1	26014-080162	BOLT, M8X 16	1							
21	1	26106-060202	BOLT, M6X 20 PLATED	2							
22	1	26106-080302	BOLT, M8X 30 PLATED	2							
23	1	26116-060504	BOLT, M6X 50 PLATED	1							
24	1	26756-060002	NUT, LOCK M6	1							

Fig.10. FUEL INJECTION PUMP

(A)=TF120DIL
(B)=
(C)=

(D)=
(E)=
(F)=

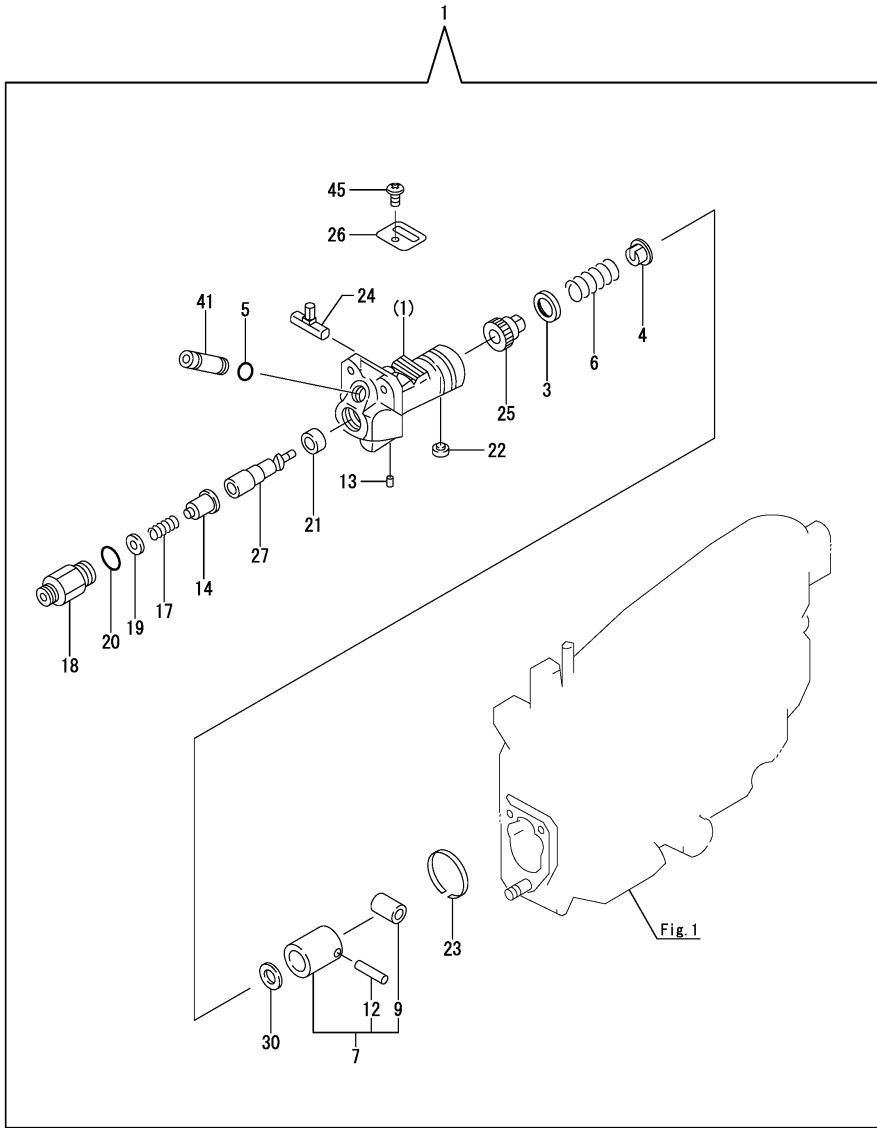

No.	Lev.	Parts No.	Description	Q'ty						I	R
				(A)	(B)	(C)	(D)	(E)	(F)		
1	1	705600-51103	FOP ASSY	1							
3	2	158600-51170	RETAINER, SPRING	1							
4	2	174307-51181	RETAINER, SPRING B	1							
5	2	114250-51190	O-RING, S27	1							
6	2	124950-51190	SPRING, PLUNGER	1							
7	2	724550-51520	GUIDE, PLUNGER	1							
9	3	711100-51540	ROLLER ASSY	1							
12	3	174100-54120	PIN, TAPPET ROLLER	1							
13	2	103854-51251	PIN, PLUNGER	1							
14	2	105300-51300	VALVE ASSY, DELIVERY	1							
17	2	124550-51320	SPRING, DELIVERY	1							
18	2	124550-51341	HOLDER, DELIVERY L43	1							
19	2	124550-51350	GASKET, DELIVERY	1							A
20	2	124550-51370	O-RING	1							A
21	2	105300-51400	DEFLECTOR	1							
22	2	104271-51450	PIECE, GUIDE	1							
23	2	104271-51460	CIRCLIP	1							
24	2	105300-51500	RACK, CONTROL	1							
25	2	105300-51510	PINION	1							
26	2	105300-51550	RETAINER, RACK	1							
27	2	105500-51600	PLUNGER ASSY	1							
30	2	174307-51700	SHIM SET, PLUNGER	1							
41	2	105300-51800	JOINT	1							
45	2	26022-050102	SCREW, M5X10	1							

Remarks
(A)Gasket kit is shown in Fig.16.

Fig.11. FUEL INJECTION DEVICE

(A)=TF120DIL
(B)=
(C)=

(D)=
(E)=
(F)=

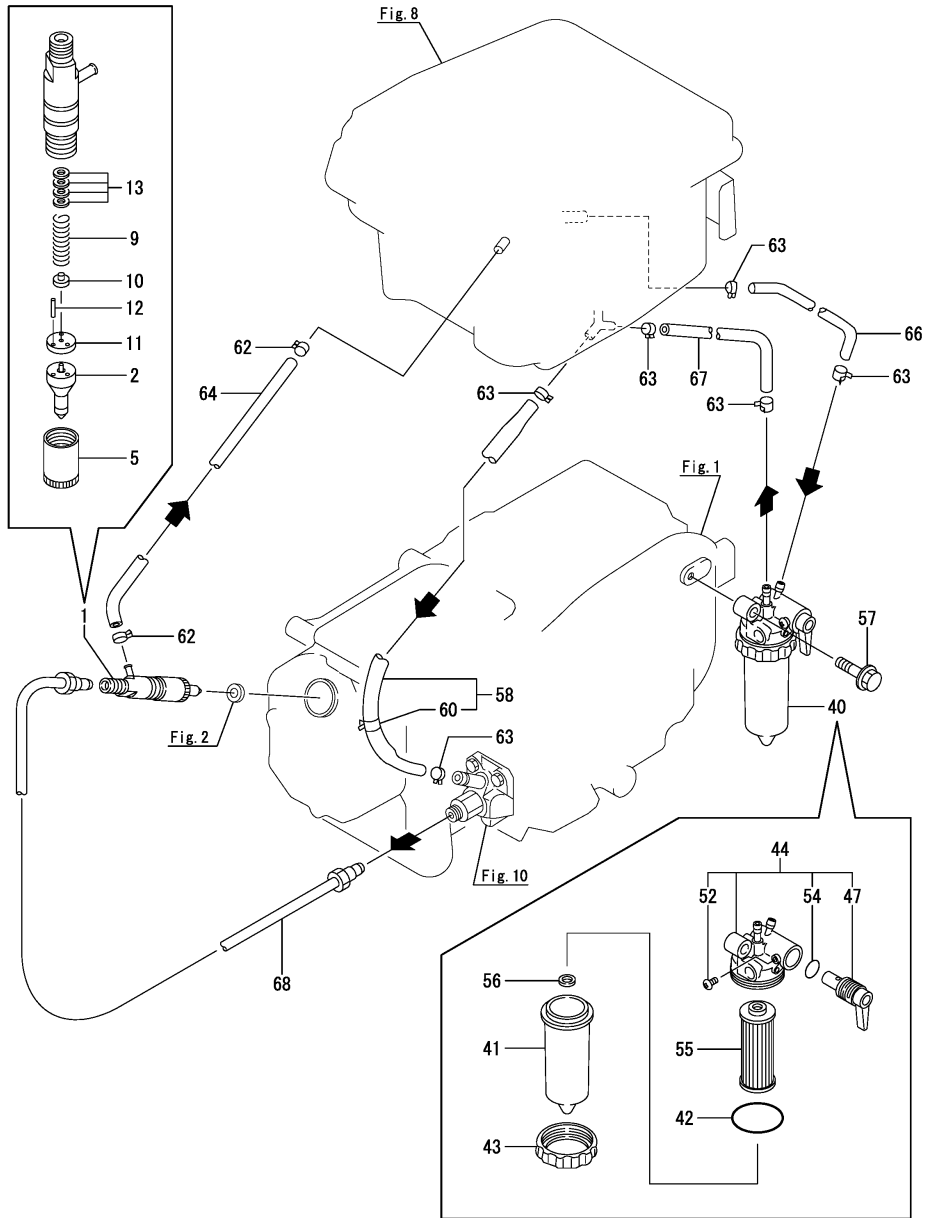

No.	Lev.	Parts No.	Description	Q'ty						I	R
				(A)	(B)	(C)	(D)	(E)	(F)		
1	1	705500-53100	FUEL INJECTOR ASSY	1							
2	2	105500-53000	VALVE ASSY,INJECTION	1							
5	2	114250-53080	NUT, NOZZLE	1							
9	2	114250-53120	SPRING, NOZZLE	1							
10	2	114250-53130	SEAT, SPRING	1							
11	2	114250-53140	SPACER	1							
12	2	114250-53210	PIN	2							
13	2	119803-53400	SHIM SET	1							
40	1	105198-55600	STRAINER ASSY, FUEL	1							
41	2	105198-55510	CUP, STRAINER	1							
42	2	105300-55520	O-RING	1							A
43	2	105300-55610	RING, RETAINING	1							
44	2	105300-55700	BODY ASSY, STRAINER	1							
47	3	105300-55340	LEVER	1							
52	3	104200-55750	SCREW, PAN M4	1							
54	3	24311-000160	O-RING, 1AP16.0	1							
55	2	105370-55711	ELEMENT	1							
56	2	105300-55750	FLOAT	1							
57	1	26106-080302	BOLT, M8X 30 PLATED	1							
58	1	10550H-59020	PIPE ASSY, FUEL OIL	1							
60	2	124766-59050	CLAMP, HOSE 11.5	1							
62	1	124722-59050	CLAMP, HOSE 9	2							
63	1	124766-59050	CLAMP, HOSE 11.5	6							
64	1	10550H-59100	RETURN TUBE, FUEL OIL	1							
66	1	10550H-59560	PIPE, FUEL OIL	1							
67	1	10550H-59570	PIPE, FUEL OIL	1							
68	1	10550H-59800	PIPE ASSY, INJECTION	1							

Remarks

(A)Gasket kit is shown in Fig.16.

N:Old $\xrightarrow{\text{Yes}}$ New, Q:Old $\xrightarrow{\text{No}}$ New, R:Old $\xrightarrow{\text{Yes}}$ New, S:Old $\xrightarrow{\text{No}}$ New, W:Add, Z:Discontinued, F:Interchangeable by set, K:Q'ty Change

Fig.12. GOVERNOR & CONTROL EQUIPMENT

(A)=TF120DIL
(B)=
(C)=

(D)=
(E)=
(F)=

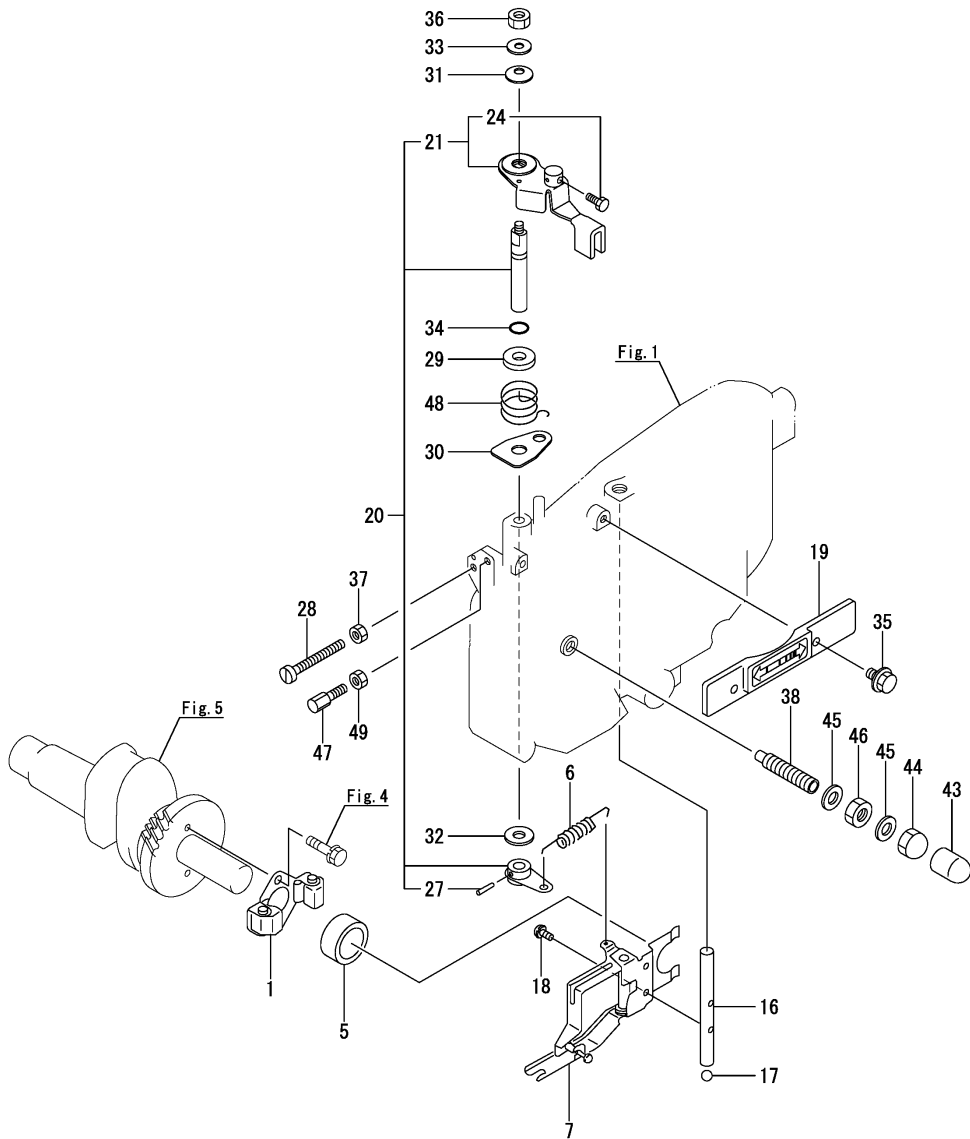

No.	Lev.	Parts No.	Description	Q'ty						I	R
				(A)	(B)	(C)	(D)	(E)	(F)		
1	1	705300-61701	GOVERNOR ASSY	1							
5	1	10530H-61600	SLEEVE, GOVERNOR	1							
6	1	10540H-66010	SPRING, REGULATOR	1							
7	1	105500-66310	LEVER ASSY, GOVERNOR	1							
16	1	105300-66400	SHAFT	1							
17	1	24190-120001	BALL, STEEL 3/8	1							
18	1	26022-050102	SCREW, M5X10	2							
19	1	10530H-66110	COVER, HANDLE	1							
20	1	10550H-66150	LEVER ASSY, HANDLE	1							
21	2	10550H-66040	HANDLE COMP,REGULATO	1							
24	3	10530H-66990	SCREW, INNER WIRE	1							
27	2	22322-030220	PIN, TAPER 3X22	1							
28	1	105300-66520	SCREW	1							
29	1	10530H-66830	PLATE, FRICTION	1							
30	1	10530H-66850	RETAINER	1							
31	1	10540H-66880	SPRING	1							
32	1	22117-100000	WASHER, 10	1							
33	1	22137-060000	WASHER, 6	1							
34	1	24311-000070	O-RING, 1AP7.0	1							
35	1	26014-060142	BOLT, M6X 14	2							
36	1	26347-060002	NUT, M6	1							
37	1	26756-060002	NUT, LOCK M6	1							
38	1	105500-66551	LIMITER ASSY, FUEL	1							
43	1	10530H-66610	CAP (F.O. LIMITTER	1							
44	1	124060-66950	NUT, CAP M10	1							
45	1	22190-100002	WASHER, SEAL 10	2							
46	1	26796-100002	NUT, LOCK M10	1							
47	1	102100-67080	BOLT, ADJUST	1							
48	1	105502-67301	SPRING, RETURN	1							
49	1	26756-060002	NUT, LOCK M6	1							

Fig.13. LAMP

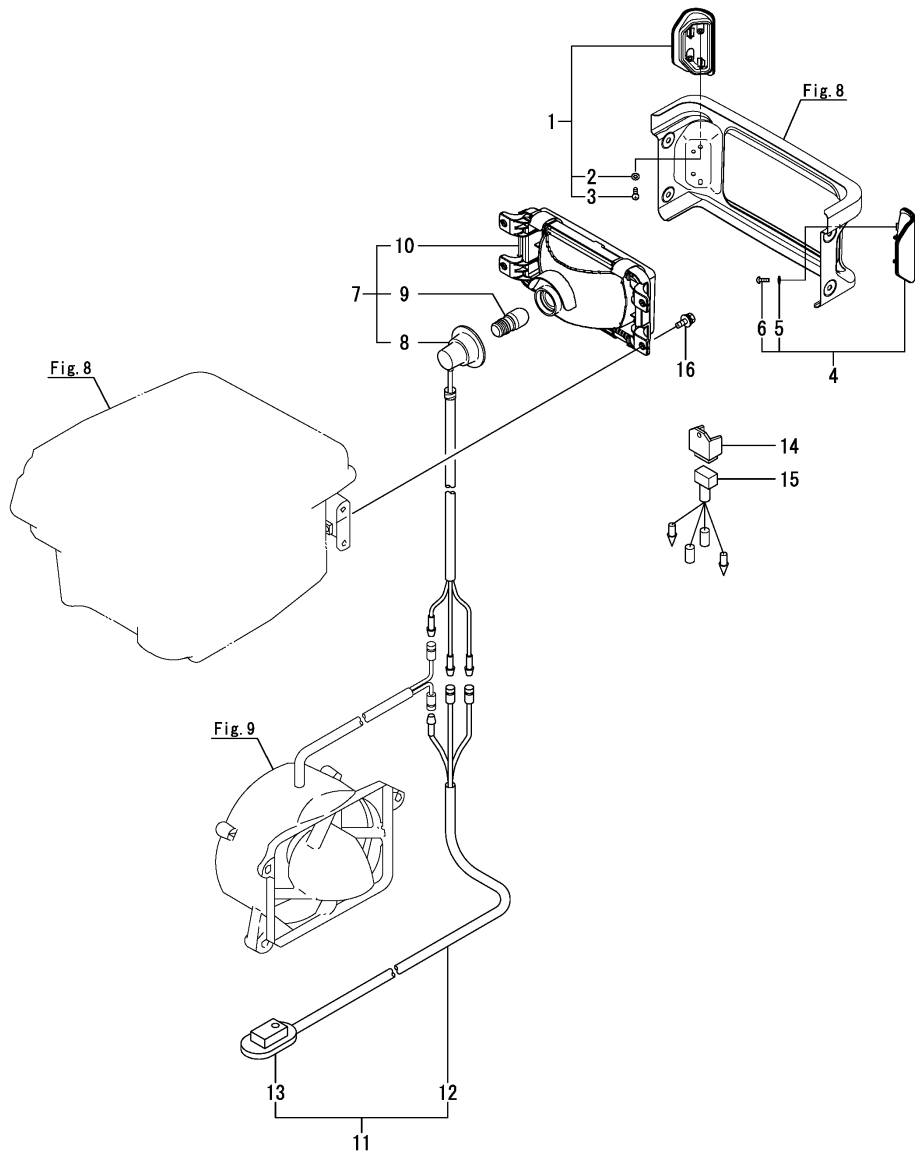

(A)=TF120DIL
(B)=
(C)=

(D)=
(E)=
(F)=

No.	Lev.	Parts No.	Description	Q'ty						I	R
				(A)	(B)	(C)	(D)	(E)	(F)		
1	1	10530H-55450	REFLECTOR(R ASSY	1							
2	2	22137-040000	WASHER, 4	2							
3	2	22857-400160	SCREW, 4X16	2							
4	1	10530H-55460	REFLECTOR(L ASSY	1							
5	2	22137-040000	WASHER, 4	2							
6	2	22857-400160	SCREW, 4X16	2							
7	1	10530H-78030	LAMP ASSY	1							
8	2	10530H-78040	SOCKET ASSY	1							
9	2	10530H-78260	BULB, 32W	1							
10	2	10530H-78270	LAMP, UNIT	1							
11	1	10530H-78520	SWITCH ASSY, RIGHT	1							
12	2	10530H-78530	HARNESS, WIRE	1							
13	2	10530H-78960	SWITCH, LIGHT	1							
14	1	10530H-78540	REGULATOR	1							
15	1	10530H-78550	WIRE HARNESS	1							
16	1	26014-060162	BOLT, M6X 16	4							

Fig.14. TOOL & LABEL

(A)=TF120DIL
(B)=
(C)=

(D)=
(E)=
(F)=

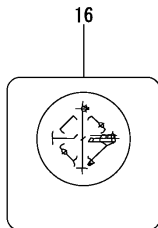
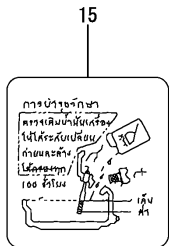
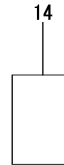
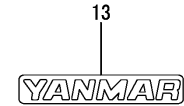
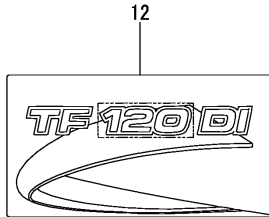
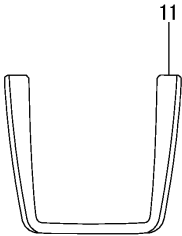
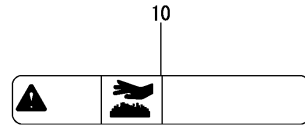
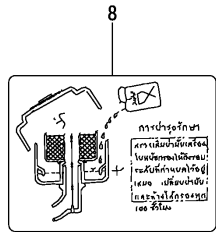
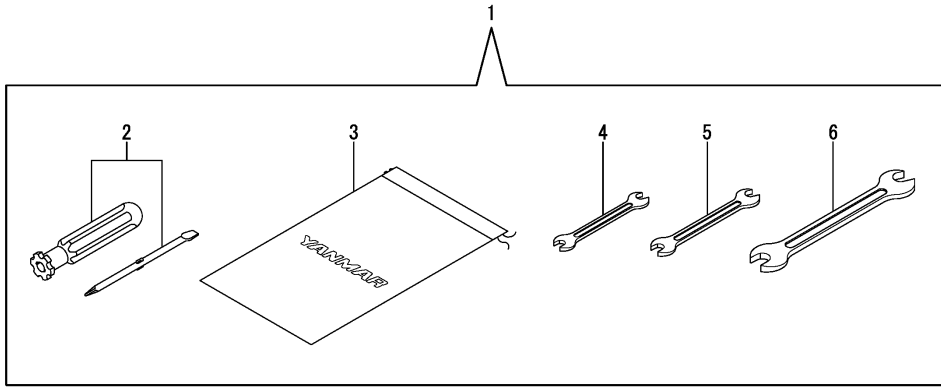

No.	Lev.	Parts No.	Description	Q'ty						I	R
				(A)	(B)	(C)	(D)	(E)	(F)		
1	1	10530H-92100	TOOL SET CMP	1							
2	2	104200-92350	SCREW-DRIVER	1							
3	2	10530G-92600	BAG, TOOL	1							
4	2	28110-100120	SPANNER, 10X12	1							
5	2	28110-140170	SPANNER, 14X17	1							
6	2	28110-190220	SPANNER, 19X22	1							
8	1	10540H-07210	LABEL, AIR CLEANER	1							
9	1	10560H-07220	LABEL, ENERGY SAVING	1							
10	1	10537H-07330	LABEL, CAUTION	1							
11	1	10550H-07500	LABEL, STRIPE	1							
12	1	10560H-07520	LABEL, MODEL NAME	1							
13	1	10530H-07530	LABEL, YANMAR	1							
14	1	10540H-07640	LABEL, F.O. STRAINER	1							
15	1	10540H-07670	LABEL, CAUTION	1							
16	1	10530H-07720	LABEL, TIS MARK	1							
17	1	10530H-07750	LABEL, RADIATOR	1							
18	1	10530H-07781	LABEL, WARRANTY 2	1							

Fig.15. BUNDLED ITEMS

(A)=TF120DIL
(B)=
(C)=

(D)=
(E)=
(F)=

No.	Lev.	Parts No.	Description	Q'ty						I	R
				(A)	(B)	(C)	(D)	(E)	(F)		
1	1	10530H-92510	OIL, YANMAR GENUINE	1							
2	1	10540H-92701	COOLANT	1							
3	1	10547H-95711	CARD, MAINTENANCE	1							
4	1	10537H-97132	CARD, ACCESSORY	1							
5	1	22217-120000	WASHER, SPRING 12	3							
6	1	26206-120352	BOLT, M12X 35 PLATED	3							
7	1	26617-120002	BOLT, EYE M12	1							

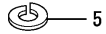
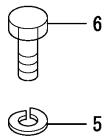
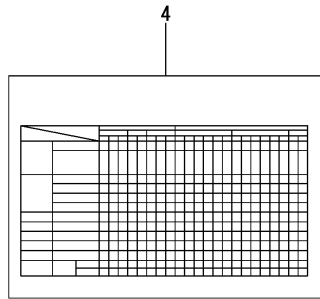
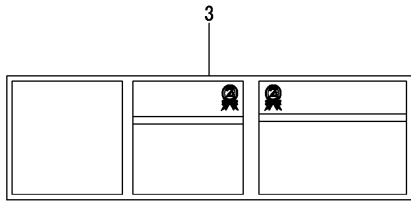
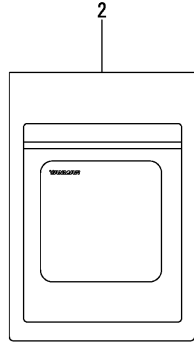
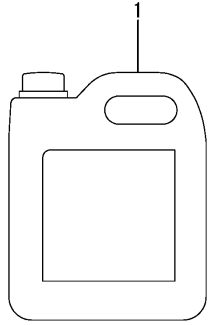
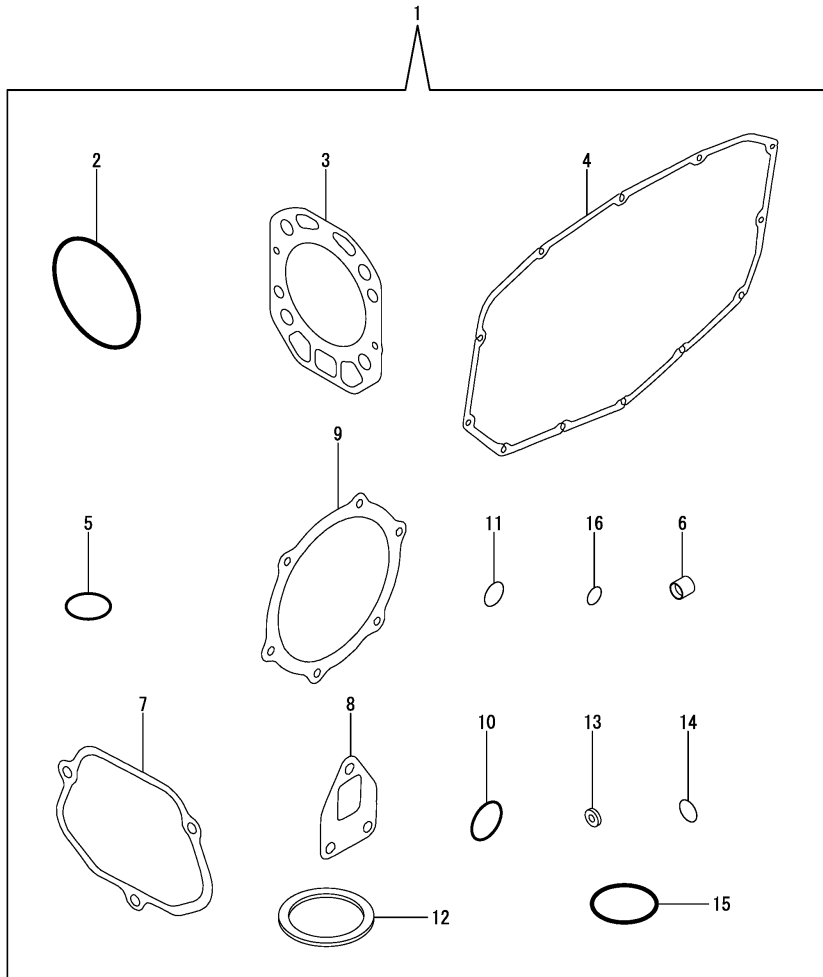

Fig.16. GASKET SET(OPTIONAL)

(A)=TF120DIL
(B)=
(C)=

(D)=
(E)=
(F)=



No.	Lev.	Parts No.	Description	Q'ty						I	R
				(A)	(B)	(C)	(D)	(E)	(F)		
1	1	10550H-92600	GASKET KIT	1							1
2	2	10550H-01300	O-RING, CYL. LINER	2							
3	2	105500-01331	GASKET, HEAD	1							
4	2	105500-01410	GASKET	1							
5	2	24311-000320	O-RING, 1AP32.0	1							
6	2	119625-11871	PROTECTOR, NOZZLE	1							
7	2	10550H-11310	GASKET	1							
8	2	105500-13201	GASKET, SILENCER	1							
9	2	105500-02020	GASKET	1							
10	2	103854-32051	O-RING	1							
11	2	24341-000200	O-RING, 1AS20.0	1							
12	2	10530H-55050	GASKET	1							
13	2	124550-51350	GASKET, DELIVERY	1							
14	2	124550-51370	O-RING	1							
15	2	105300-55520	O-RING	1							
16	2	24311-000070	O-RING, 1AP7.0	1							

Remarks

(1)Optional parts.

Parts No. Index

Parts No.	Fig. No.	Ref. No.
101158-03111	7	20
101158-11230	2	17
		21
101504-55101	8	35
102100-67080	12	47
103338-01240	1	11
103338-11180	2	10
103854-32051	7	1
	16	10
103854-32082	7	2
103854-51251	10	13
103854-55220	8	38
104104-03750	2	36
104200-03641	2	38
104200-55750	11	52
104200-92350	14	2
104271-21100	5	5
104271-51450	10	22
104271-51460	10	23
104300-01220	1	10
104300-08050	7	45
104300-55160	8	36
104300-76460	4	10
104407-21600	5	12
104507-07920	8	54
104607-44540	8	12
104700-55220	8	39
105010-11920	2	26
105100-01660	1	19
105198-55510	11	41
105198-55600	11	40
105215-76490	4	25
105300-01690	1	28
105300-14090	4	3
105300-14700	4	9
105300-28450	4	20
105300-28700	4	21
105300-34040	1	21
105300-44220	8	1
105300-44451	8	6
105300-44460	8	7
105300-51300	10	14
105300-51400	10	21
105300-51500	10	24
105300-51510	10	25
105300-51550	10	26
105300-51800	10	41
105300-55340	11	47
105300-55520	11	42
	16	15

Parts No.	Fig. No.	Ref. No.
105300-55610	11	43
105300-55700	11	44
105300-55750	11	56
105300-66400	12	16
105300-66520	12	28
105300-76470	7	38
105300-76490	7	39
105306-35052	7	13
10530G-08510	7	28
10530G-76330	7	34
		35
10530G-92600	14	3
10530H-01800	1	30
10530H-01920	1	31
10530H-01950	1	32
10530H-01960	1	33
10530H-01970	1	34
10530H-03550	2	34
10530H-03610	2	35
10530H-07530	14	13
10530H-07720	14	16
10530H-07750	14	17
10530H-07781	14	18
10530H-11900	2	25
10530H-12860	3	14
10530H-14200	4	6
10530H-32200	7	3
10530H-34850	1	44
10530H-44570	8	9
10530H-44600	8	11
10530H-44630	8	15
10530H-44720	9	5
10530H-44780	9	9
10530H-55050	8	29
	16	12
10530H-55450	13	1
10530H-55460	13	4
10530H-55520	8	45
10530H-61600	12	5
10530H-66110	12	19
10530H-66610	12	43
10530H-66830	12	29
10530H-66850	12	30
10530H-66990	12	24
10530H-78010	9	10
10530H-78030	13	7
10530H-78040	13	8
10530H-78260	13	9
10530H-78270	13	10
10530H-78520	13	11

Parts No.	Fig. No.	Ref. No.
10530H-78530	13	12
10530H-78540	13	14
10530H-78550	13	15
10530H-78960	13	13
10530H-92100	14	1
10530H-92510	15	1
105340-44701	9	3
105340-44750	9	7
105362-78960	7	21
105370-55711	11	55
10537H-03060	7	18
10537H-07330	14	10
10537H-14190	4	5
10537H-32500	7	4
10537H-97132	15	4
10540H-01751	1	29
10540H-07210	14	8
10540H-07640	14	14
10540H-07670	14	15
10540H-66010	12	6
10540H-66880	12	31
10540H-76940	8	16
		47
10540H-92701	15	2
105430-28720	4	23
10547H-55050	8	28
10547H-95711	15	3
105500-01200	1	9
105500-01331	1	12
	16	3
105500-01410	1	25
	16	4
105500-02020	5	19
	16	9
105500-03130	7	23
105500-07910	8	53
105500-11015	2	1
105500-11100	2	7
105500-11111	2	8
105500-11340	2	14
105500-13201	3	21
	16	8
105500-22300	6	8
105500-22400	6	9
105500-23200	6	14
105500-23500	6	10
105500-23910	6	12
105500-28251	4	14
105500-28380	4	18
105500-51600	10	27

Parts No.	Fig. No.	Ref. No.
105500-53000	11	2
105500-66310	12	7
105500-66551	12	38
105502-67301	12	48
10550G-28750	4	22
10550H-01300	1	8
	16	2
10550H-01481	1	26
10550H-01490	1	27
10550H-02230	5	16
10550H-02300	5	20
10550H-02320	5	17
10550H-03070	7	17
10550H-07500	14	11
10550H-07940	8	55
10550H-08020	7	44
10550H-11290	2	11
10550H-11310	2	42
	16	7
10550H-11520	2	33
10550H-11650	2	15
10550H-11660	2	19
10550H-12060	3	2
10550H-12851	3	13
10550H-13570	3	31
10550H-14400	4	7
10550H-14600	4	8
10550H-21100	5	6
10550H-21530	5	11
10550H-44210	9	1
10550H-44370	8	5
10550H-44611	8	14
10550H-44701	9	4
10550H-44760	9	8
10550H-44830	9	14
10550H-44950	9	16
10550H-55830	8	46
10550H-59020	11	58
10550H-59100	11	64
10550H-59560	11	66
10550H-59570	11	67
10550H-59800	11	68
10550H-66040	12	21
10550H-66150	12	20
10550H-92600	16	1
10557H-11120	2	9
10557H-14010	4	1
10557H-21290	5	7
10557H-21520	5	8
105582-34100	7	11

Parts No. Index

Parts No.	Fig. No.	Ref. No.
105600-01560	1	1
105600-11800	2	2
105600-22470	6	18
105600-22480	6	25
105600-22510	6	20
105600-22520	6	27
10560G-28300	4	16
10560G-28310	4	17
10560H-01390	1	13
10560H-01900	1	5
10560H-02310	5	21
10560H-02500	5	14
10560H-07220	14	9
10560H-07520	14	12
10560H-12030	3	1
10560H-12510	3	3
10560H-12700	3	4
10560H-12750	3	6
10560H-12800	3	7
10560H-13512	3	22
10560H-14100	4	4
10560H-21200	5	9
10560H-21400	5	10
10560H-21700	5	1
10560H-28410	4	19
10560H-44250	8	2
10560H-44330	8	3
10560H-44340	8	4
10560H-44501	8	8
10560H-55040	8	27
10560H-55240	8	40
10567H-07110	8	26
10567H-22190	6	1
10567H-22500	6	3
10567H-55300	8	41
10567H-55330	8	43
10570H-08101	7	27
10570H-12551	3	16
10570H-12710	3	5
10570H-76340	7	36
10570H-76480	7	37
10570H-76790	7	40
10571H-61250	1	24
106100-44560	8	13
10610H-44651	9	15
106383-44740	9	6
114250-51190	10	5
114250-53080	11	5
114250-53120	11	9
114250-53130	11	10

Parts No.	Fig. No.	Ref. No.
114250-53140	11	11
114250-53210	11	12
119625-11871	2	23
	16	6
119625-11880	2	24
119803-53400	11	13
121250-44590	8	10
123672-83880	4	26
124060-66950	12	44
124550-51320	10	17
124550-51341	10	18
124550-51350	10	19
	16	13
124550-51370	10	20
	16	14
124722-59050	11	62
124766-59050	11	60
		63
124950-51190	10	6
158600-51170	10	3
160725-78350	8	17
174100-54120	10	12
174307-51181	10	4
174307-51700	10	30
22117-060000	8	18
22117-100000	12	32
22137-040000	13	2
		5
22137-060000	12	33
22190-100002	12	45
22217-040000	7	22
22217-060000	8	19
22217-080000	3	32
	9	17
22217-120000	7	46
	9	11
	15	5
22242-000200	7	43
22242-000500	5	22
22252-000100	1	22
22312-030180	2	40
22322-030160	2	37
22322-030220	12	27
22351-060012	1	4
		20
	2	6
22857-400160	13	3
		6
23064-090330	7	24
24101-060054	4	27

Parts No.	Fig. No.	Ref. No.
24101-060064	4	11
24101-060094	4	28
24107-062013	9	12
24190-120001	1	23
	12	17
24311-000060	1	35
24311-000070	2	41
	12	34
	16	16
24311-000160	11	54
24311-000320	1	36
	16	5
24321-000250	1	37
24321-000450	3	18
24341-000200	7	16
	16	11
24351-350530	3	15
25117-003801	9	19
26013-060142	8	20
26013-060162	8	21
26013-060182	8	22
		23
26013-060222	4	29
26013-080202	5	23
26014-060142	8	24
		48
	12	35
26014-060162	8	25
	13	16
26014-080162	9	20
26022-050102	10	45
	12	18
26022-060122	4	12
26106-060122	5	13
	7	10
		32
26106-060142	1	38
26106-060202	2	43
	9	21
26106-060222	7	25
26106-060252	1	39
	7	26
26106-060652	1	40
26106-060702	2	44
26106-080142	4	30
26106-080162	8	49
26106-080202	3	19
26106-080222	8	50
26106-080302	9	22
	11	57

Parts No.	Fig. No.	Ref. No.
26106-100202	8	51
26106-100552	4	31
26116-060102	5	18
26116-060504	9	23
26206-120352	15	6
26216-060302	2	27
26216-080202	3	33
26216-080222	1	41
26216-080502	2	28
26347-060002	12	36
26366-060002	1	42
	2	29
26366-080002	1	43
	2	30
	3	34
	9	18
26557-060102	7	33
	8	52
26557-060202	3	35
26587-080122	4	13
26617-120002	15	7
26636-080002	3	20
26706-120002	7	47
26756-060002	9	24
	12	37
		49
26756-080002	2	18
		22
26777-120002	9	13
26796-100002	12	46
27310-080001	2	31
28110-100120	14	4
28110-140170	14	5
28110-190220	14	6
705300-61701	12	1
705500-23600	6	16
705500-23610	6	32
705500-23620	6	34
705500-53100	11	1
705600-51103	10	1
711100-51540	10	9
724550-51520	10	7