

0CC50-M00590EN

Introduction

1. This parts catalog is a first edition of the TF090DIL diesel engine.

	Date of issue	Remarks
First edition	Mar., 2016	

2. This parts catalog does not contain the technical data needed for maintenance service.

3. The illustrations used in this parts catalog have been simplified for clarity.

4. The contents of this parts catalog are subject to change without notice.

5. Be sure to use only Yanmar genuine parts for repairs. If imitation parts are used, it may cause engine defects.

Contents

OCC50-M00590

Fig. No. Fig. Name

Fig. No. Fig. Name

TF090DIL

1. CYLINDER BLOCK
2. BREATHER
3. ENGINE BED
4. CYLINDER HEAD & BONNET
5. AIR CLEANER & MUFFLER
6. CAMSHAFT
7. CRANKSHAFT & FLYWHEEL
8. PISTON & CONNECTING ROD
9. BALANCER
10. LUB. OIL SYSTEM
11. RADIATOR
12. FAN
13. FUEL INJECTION PUMP
14. FUEL INJECTION DEVICE
15. FUEL TANK
16. GOVERNOR & CONTROL EQUIPMENT
17. STARTING DEVICE
18. LAMP
19. LABEL
20. TOOL
21. BUNDLED ITEMS

Fig.1. CYLINDER BLOCK

(A)=TF090DIL
(B)=
(C)=

(D)=
(E)=
(F)=

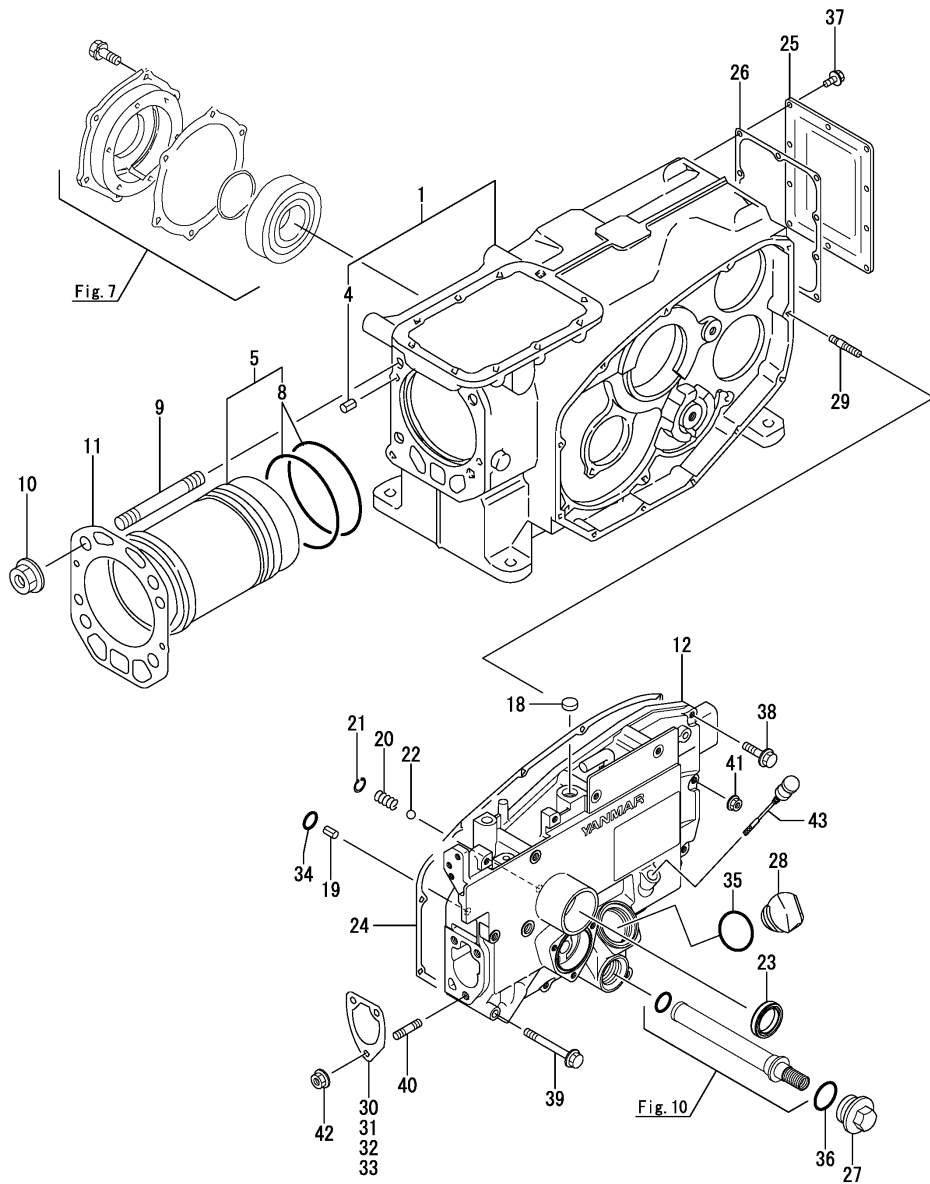

No.	Lev.	Parts No.	Description	Q'ty						I	R
				(A)	(B)	(C)	(D)	(E)	(F)		
1	1	105400-01560	BODY, CYLINDER SUB A	1							
4	2	22351-060012	PIN, SPRING 6.0X12	2							
5	1	10540H-01900	LINER,CYLINDER SUB A	1							
8	2	10530H-01300	O-RING, CYL. LINER	2							
9	1	105230-01200	BOLT, HEAD	4							
10	1	10537H-01220	NUT, CYLINDER HEAD	4							
11	1	105300-01333	GASKET, HEAD	1							
12	1	10540H-01390	CASE ASSY, GEAR	1							
18	1	105100-01660	PLUG, 14	1							
19	1	22351-060012	PIN, SPRING 6.0X12	1							
20	1	105300-34040	SPRING	1							
21	1	22252-000100	RING, 10	1							
22	1	24190-120001	BALL, STEEL 3/8	1							
23	1	10571H-61250	SEAL,OIL START SHAFT	1							
24	1	105300-01410	GASKET, GEAR CASE	1							
25	1	10530H-01481	COVER, REAR	1							
26	1	10530H-01490	GASKET, REAR COVER	1							
27	1	105300-01690	PLUG	1							
28	1	10540H-01751	CAP, FEEDER	1							
29	1	10530H-01800	BOLT	1							
30	1	10530H-01920	SHIM, T=0.3	1							
31	1	10530H-01950	SHIM, T=0.5	1							
32	1	10530H-01960	SHIM, T=0.4	1							
33	1	10530H-01970	SHIM, T=0.6	1							
34	1	24311-000060	O-RING, 1AP6.0	1							
35	1	24311-000320	O-RING, 1AP32.0	1							
36	1	24321-000250	O-RING, 1AG25.0	1							
37	1	26106-060142	BOLT, M6X 14 PLATED	10							
38	1	26106-060252	BOLT, M6X 25 PLATED	5							
39	1	26106-060652	BOLT, M6X 65 PLATED	6							
40	1	26216-080222	STUD, M8X 22	3							
41	1	26366-060002	NUT, M6	1							
42	1	26366-080002	NUT, M8	3							
43	1	10530H-34850	DIPSTICK, OIL	1							

Fig.2. BREATHER

(A)=TF090DIL
(B)=
(C)=

(D)=
(E)=
(F)=

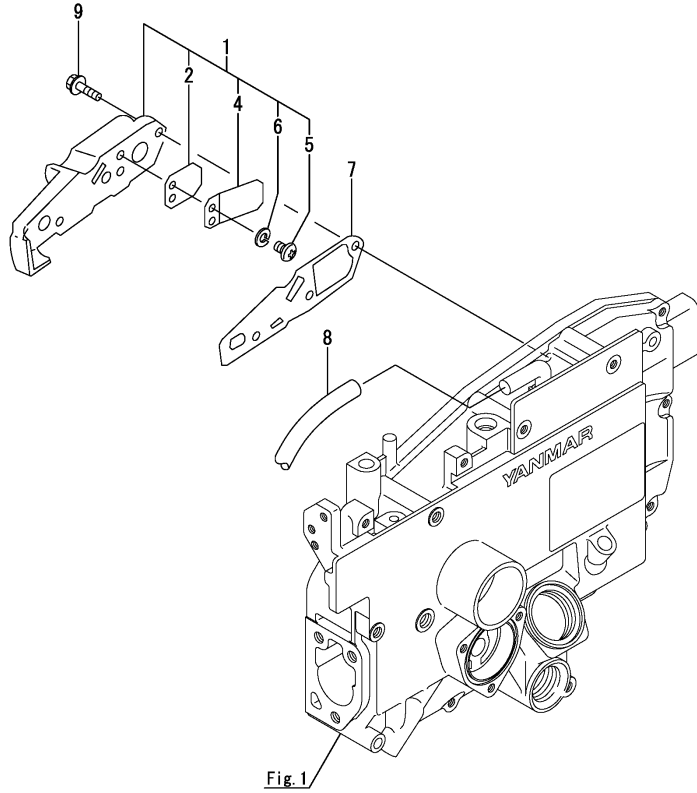

No.	Lev.	Parts No.	Description	Q'ty						I	R
				(A)	(B)	(C)	(D)	(E)	(F)		
1	1	10530H-03070	COVER ASSY, BREATHER	1							
2	2	10537H-03060	VALVE, RETURN	1							
4	2	101158-03111	RETAINER	1							
5	2	105362-78960	SCREW, M4X8	2							
6	2	22217-040000	WASHER, SPRING 4	2							
7	1	105500-03130	GASKET, BREATHER	1							
8	1	23064-090330	HOSE, 9 X 330	1							
9	1	26106-060222	BOLT, M6X 22 PLATED	3							

Fig.3. ENGINE BED

(A)=TF090DIL
(B)=
(C)=

(D)=
(E)=
(F)=

No.	Lev.	Parts No.	Description	Q'ty						I	R	
				(A)	(B)	(C)	(D)	(E)	(F)			
1	1	10530H-08020	BED, ENGINE	2								
2	1	104300-08050	BOLT, FOUNDATION	4								
3	1	22217-120000	WASHER, SPRING 12	4								
4	1	26706-120002	NUT, M12	4								

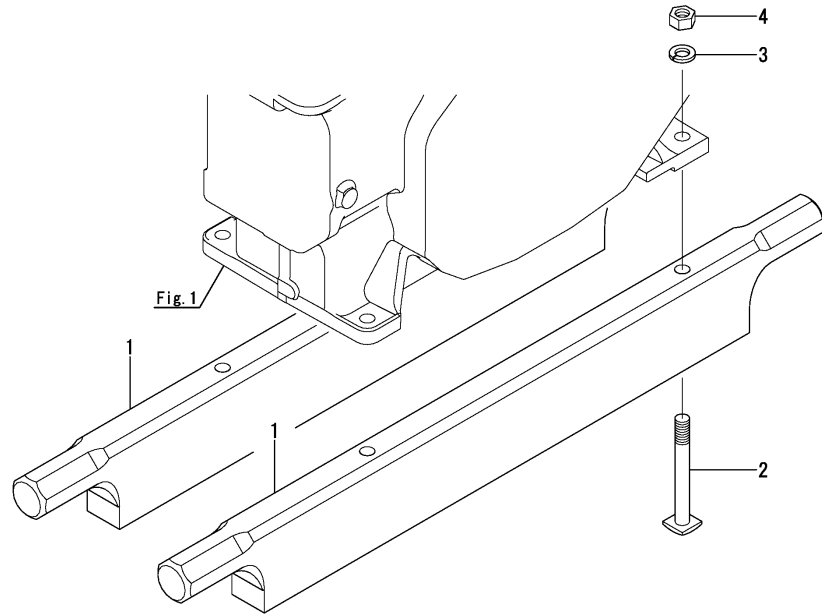

Fig.4. CYLINDER HEAD & BONNET

(A)=TF090DIL

(B)=

(C)=

(D)=

(E)=

(F)=

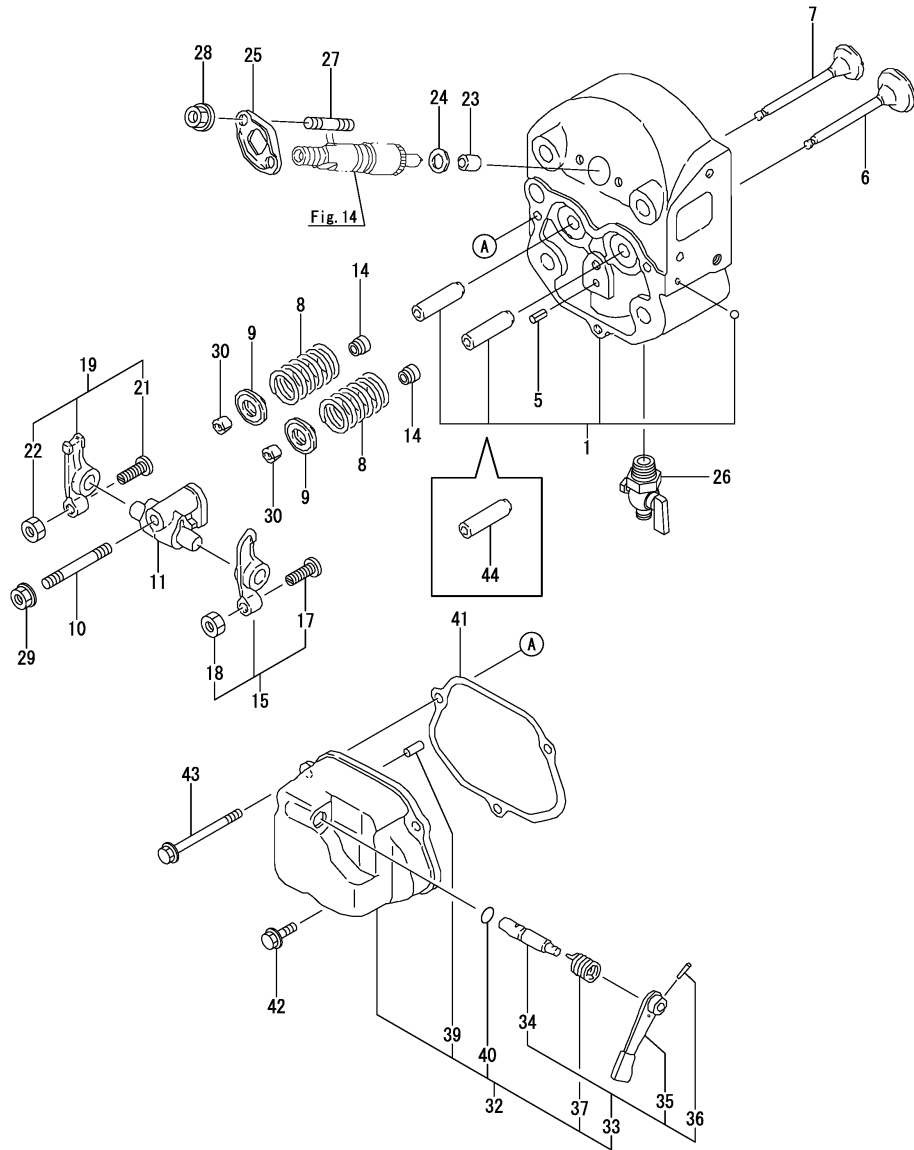

No.	Lev.	Parts No.	Description	Q'ty						I	R
				(A)	(B)	(C)	(D)	(E)	(F)		
1	1	105400-11015	HEAD ASSY, CYLINDER	1							
5	1	22351-060012	PIN, SPRING 6.0X12	1							
6	1	105300-11100	VALVE, INTAKE	1							
7	1	105300-11111	VALVE, EXHAUST	1							
8	1	10537H-11120	SPRING, VALVE	2							
9	1	101158-11180	RETAINER, SPRING	2							
10	1	10530H-11270	STUD, M8	1							
11	1	10530H-11290	SUPPORT ASSY, ARM	1							
14	1	128170-11340	SEAL, VALVE STEM	2							
15	1	10530H-11650	ARM, ROCKER	1							
17	2	101158-11230	SCREW, VALVE ADJUST	1							
18	2	26756-080002	NUT, LOCK M8	1							
19	1	10530H-11660	ARM, ROCKER	1							
21	2	101158-11230	SCREW, VALVE ADJUST	1							
22	2	26756-080002	NUT, LOCK M8	1							
23	1	119625-11871	PROTECTOR, NOZZLE	1							
24	1	119625-11880	SEAT, NOZZLE	1							
25	1	10530H-11900	RETAINER, VALVE	1							
26	1	105010-11920	COCK, WATER	1							
27	1	26216-060302	STUD, M6X 30	2							
28	1	26366-060002	NUT, M6	2							
29	1	26366-080002	NUT, M8	1							
30	1	27310-070001	COTTER, 7	2							
32	1	10530G-11650	BONNET SUB ASSY	1							
33	2	10530H-03550	LEVER ASSY, DECOMP.	1							
34	3	10530H-03610	SHAFT, DECOMP LEVER	1							
35	3	104104-03750	LEVER, DECOMPRESSION	1							
36	3	22322-030160	PIN, TAPER 3X16	1							
37	2	104200-03641	SPRING, DECOMPRESSION	1							
39	2	22312-030180	PIN, PARALLEL M3X18	1							
40	2	24311-000070	O-RING, 1AP7.0	1							
41	1	10530H-11310	GASKET	1							
42	1	26106-060202	BOLT, M6X 20 PLATED	2							
43	1	26106-060602	BOLT, M6X 60 PLATED	1							
44	1	105400-11800	GUIDE, VALVE	2							1

Remarks

(1) Spare parts.

Fig.5. AIR CLEANER & MUFFLER

(A)=TF090DIL
(B)=
(C)=

(D)=
(E)=
(F)=

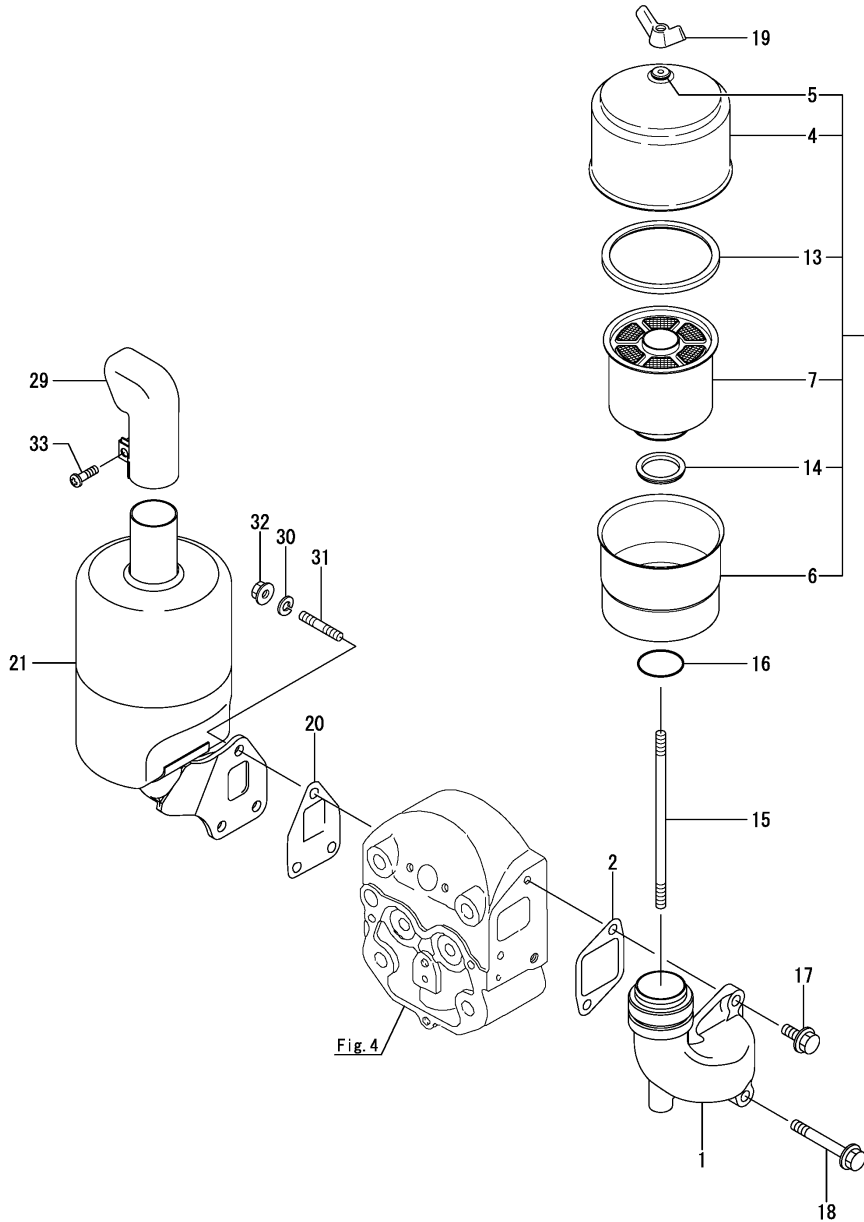

No.	Lev.	Parts No.	Description	Q'ty						I	R
				(A)	(B)	(C)	(D)	(E)	(F)		
1	1	10540H-12031	PIPE, INTAKE	1							
2	1	105400-12050	GASKET	1							
3	1	10540H-12510	CLEANER ASSY, AIR	1							
4	2	10540H-12700	CAP, AIR CLEANER	1							
5	2	10570H-12710	WASHER, SEAL	1							
6	2	10540H-12750	BODY, AIR CLEANER	1							
7	2	10540H-12800	ELEMENT, AIR CLEANER	1							
13	2	10530H-12851	RUBBER, NO1	1							
14	2	10530H-12860	RUBBER, NO2	1							
15	1	10540H-12550	BOLT, AIR CLEANER	1							
16	1	24321-000450	O-RING, 1AG45.0	1							
17	1	26106-080202	BOLT, M8X 20 PLATED	1							
18	1	26106-080602	BOLT, M8X 60 PLATED	1							
19	1	26636-080002	NUT, WING M8	1							
20	1	105300-13201	GASKET, SILENCER	1							
21	1	10540H-13512	SILENCER	1							
29	1	10530H-13570	PIPE, EXHAUST	1							
30	1	22217-080000	WASHER, SPRING 8	3							
31	1	26216-080202	STUD, M8X 20	3							
32	1	26366-080002	NUT, M8	3							
33	1	26557-060202	SCREW, M6X20	1							

Fig.6. CAMSHAFT

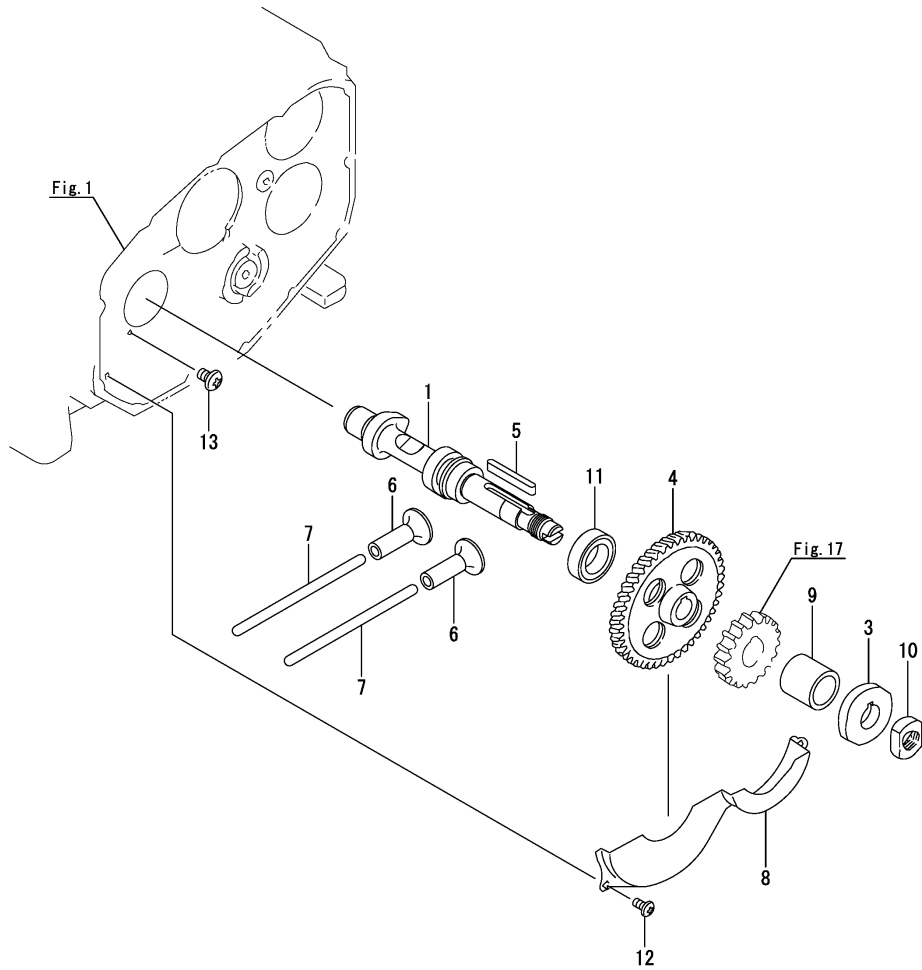

(A)=TF090DIL
(B)=
(C)=

(D)=
(E)=
(F)=

No.	Lev.	Parts No.	Description	Q'ty						I	R
				(A)	(B)	(C)	(D)	(E)	(F)		
1	1	10537H-14010	CAMSHAFT ASSY	1							
3	1	105300-14090	CAM, FUEL	1							
4	1	10540H-14100	GEAR, CAMSHAFT	1							
5	1	10537H-14190	KEY, CAMSHAFT GEAR	1							
6	1	10530H-14200	TAPPET	2							
7	1	10530H-14400	ROD, PUSH	2							
8	1	10530H-14600	COVER	1							
9	1	105300-14700	SPACER	1							
10	1	104300-76460	NUT	1							
11	1	24101-060064	BEARING, BALL 6006	1							
12	1	26022-060122	SCREW, M6X12	3							
13	1	26587-080122	SCREW, M8X12	1							

Fig.7. CRANKSHAFT & FLYWHEEL

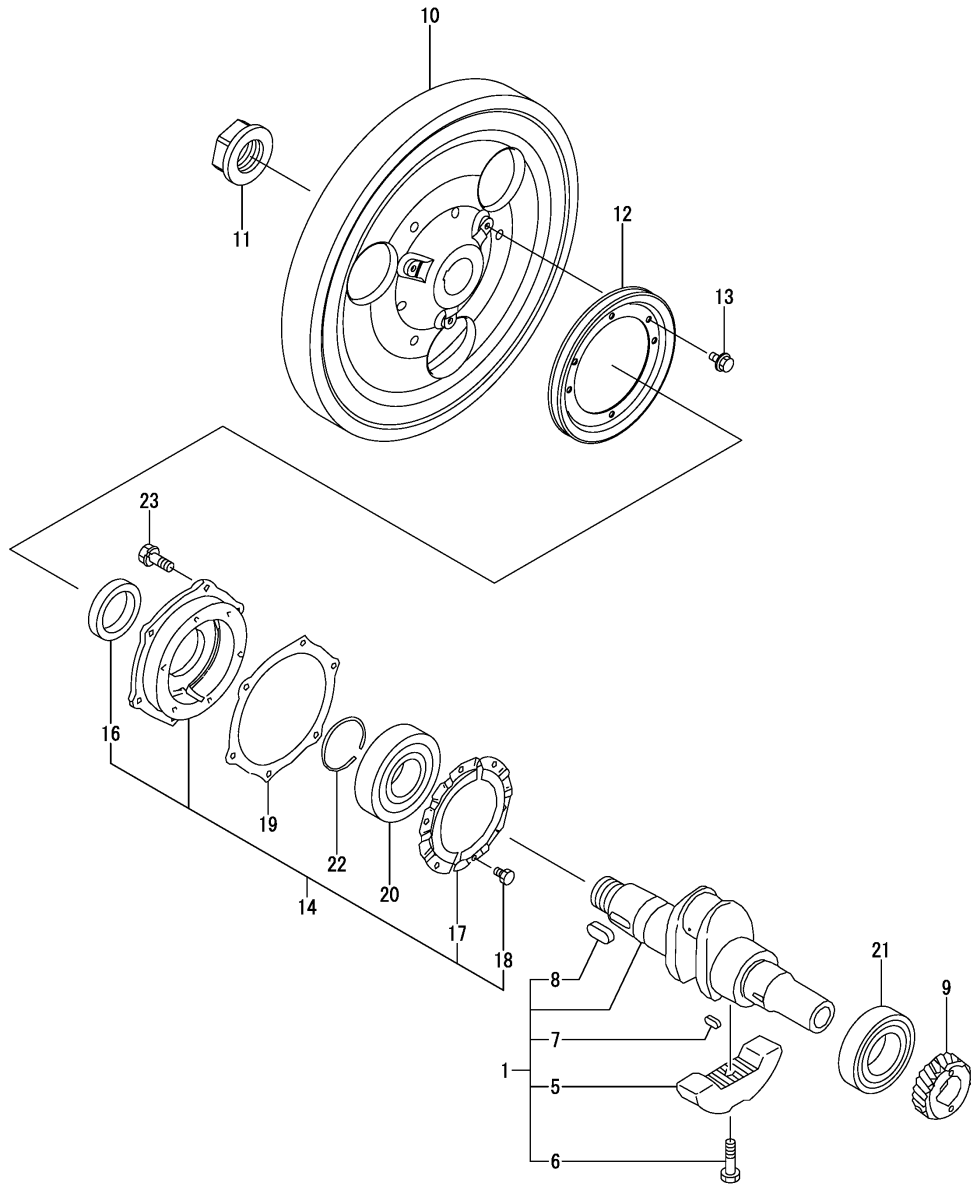

(A)=TF090DIL
(B)=
(C)=

(D)=
(E)=
(F)=

No.	Lev.	Parts No.	Description	Q'ty						I	R
				(A)	(B)	(C)	(D)	(E)	(F)		
1	1	10540H-21700	CRANKSHAFT SUB ASSY	1							
5	2	10530H-21100	WEIGHT, BALANCE	2							
6	2	106100-21130	BOLT, BALANCE WEIGHT	2							
7	2	10537H-21290	KEY, CRANKSHAFT GEAR	1							
8	2	10537H-21520	KEY, FLYWHEEL	1							
9	1	10540H-21200	GEAR, CRANKSHAFT	1							
10	1	10540H-21400	FLYWHEEL	1							
11	1	10530H-21530	NUT, END	1							
12	1	104407-21600	V-PULLEY	1							
13	1	26106-060122	BOLT, M6X 12 PLATED	3							
14	1	10540H-02500	HOUSING,MAIN METAL S	1							
16	2	10530H-02230	SEAL, OIL CRANKSHAFT	1							
17	2	10530H-02320	RETAINER	2							
18	2	26116-060102	BOLT, M6X 10 PLATED	6							
19	1	105300-02020	GASKET	1							
20	1	10530H-02300	BEARING, BL309-G,3	1							
21	1	10540H-02310	BEARING, NF308-C3	1							
22	1	22242-000450	RING, 45	1							
23	1	26013-080202	BOLT, M8X 20	6							

Fig.8. PISTON & CONNECTING ROD

(A)=TF090DIL
(B)=
(C)=

(D)=
(E)=
(F)=

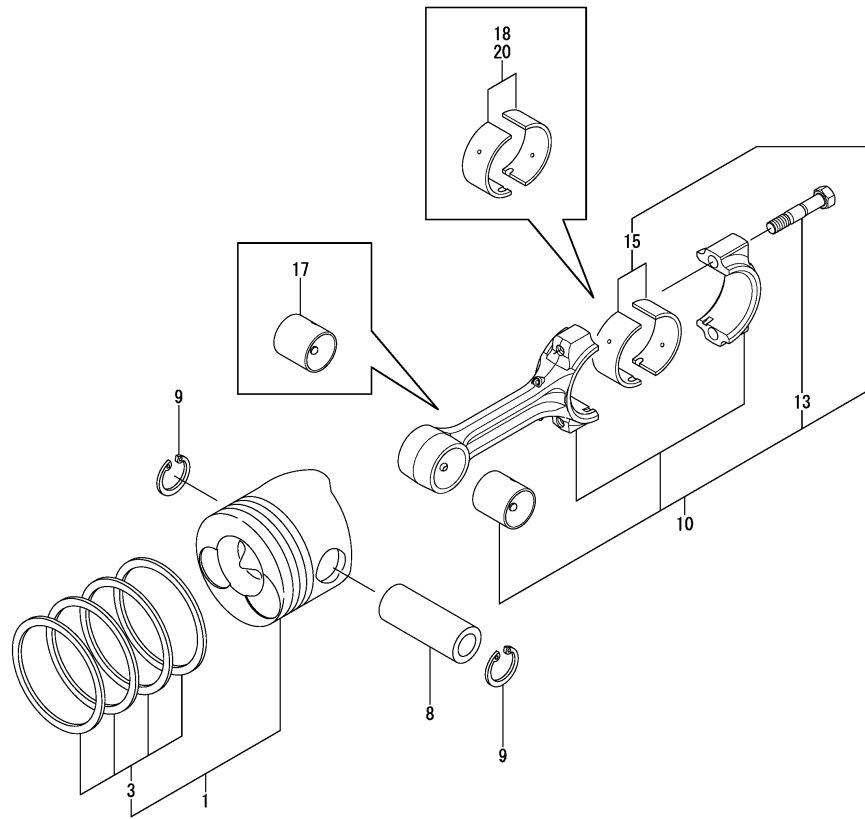

No.	Lev.	Parts No.	Description	Q'ty						I	R
				(A)	(B)	(C)	(D)	(E)	(F)		
1	1	10547H-22190	PISTON ASSY	1							
3	2	10547H-22500	RING SET, PISTON	1							
8	1	105300-22300	PIN, PISTON	1							
9	1	105300-22400	CIRCLIP	2							
10	1	105300-23500	ROD,CONNECTING SUB A	1							
13	3	105300-23200	BOLT, CONNECTING ROD	2							
15	2	705300-23600	BEARING, CRANK PIN	1							
17	1	105300-23910	BEARING, PISTON PIN	1							1
18	1	705300-23610	BEARING ASSY, 0.25	1							2
20	1	705300-23620	BEARING, 0.50 US	1							3

Remarks

- (1) Spare parts.
- (2) Under-sized(U.S.=0.25) parts.
- (3) Under-sized(U.S.=0.5) parts.

Fig.9. BALANCER

(A)=TF090DIL
(B)=
(C)=

(D)=
(E)=
(F)=

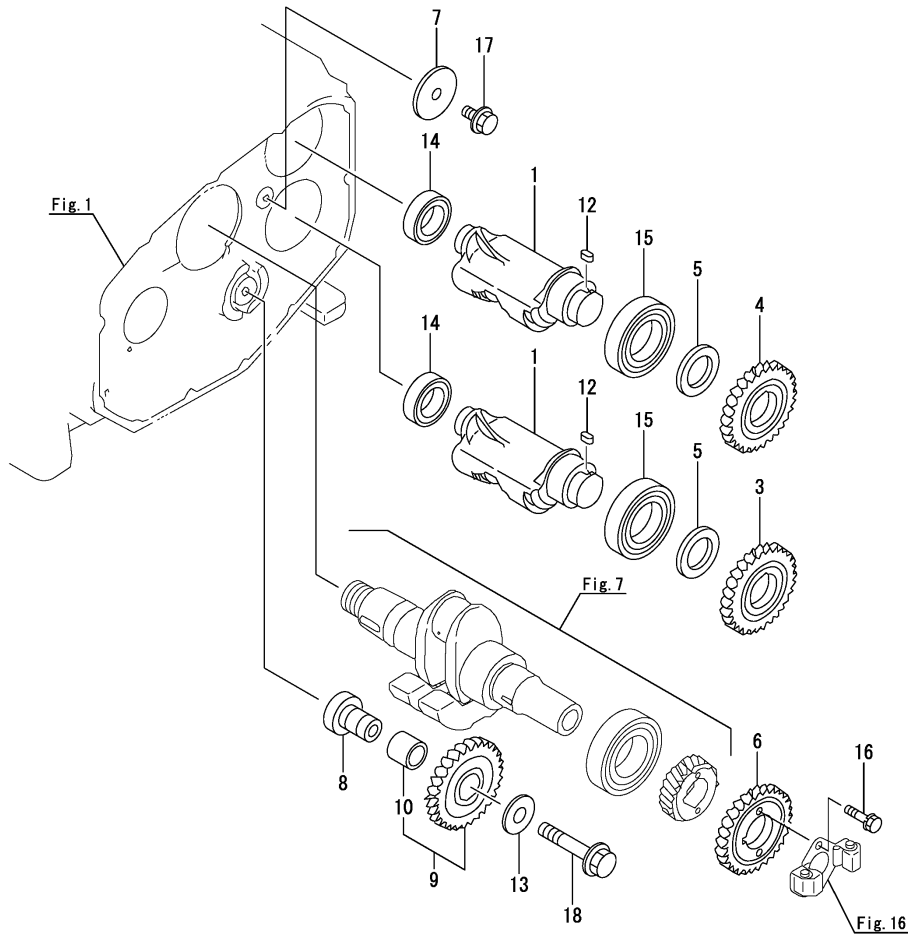

No.	Lev.	Parts No.	Description	Q'ty						I	R
				(A)	(B)	(C)	(D)	(E)	(F)		
1	1	105300-28251	SHAFT, BALANCER	2							
3	1	10540G-28300	GEAR, BALANCER	1							
4	1	10540G-28310	GEAR, BALANCER	1							
5	1	105300-28380	SPACER	2							
6	1	10540H-28410	GEAR, BALANCER	1							
7	1	105300-28450	RETAINER	1							
8	1	105300-28700	SHAFT	1							
9	1	10530G-28750	GEAR ASSY	1							
10	2	105430-28720	BUSH, IDLE GEAR	1							
12	1	105215-76490	KEY	2							
13	1	123672-83880	RETAINER	1							
14	1	24101-060054	BEARING, BALL 6005	2							
15	1	24101-060084	BEARING, BALL 6008	2							
16	1	26013-060222	BOLT, M6X 22	2							
17	1	26106-080142	BOLT, M8X 14 PLATED	1							
18	1	26106-100552	BOLT, M10X 55 PLATED	1							

Fig.10. LUB. OIL SYSTEM

(A)=TF090DIL
(B)=
(C)=

(D)=
(E)=
(F)=

No.	Lev.	Parts No.	Description	Q'ty						I	R
				(A)	(B)	(C)	(D)	(E)	(F)		
1	1	103854-32051	O-RING	1							
2	1	103854-32082	COVER	1							
3	1	10530H-32200	PIECE	1							
4	1	10537H-32500	PUMP, LUB.OIL CMP	1							
10	1	26106-060122	BOLT, M6X 12 PLATED	3							
11	1	105582-34100	SIGNAL	1							
13	1	105306-35052	STRAINER ASSY, OIL	1							
16	1	24341-000200	O-RING, 1AS20.0	1							

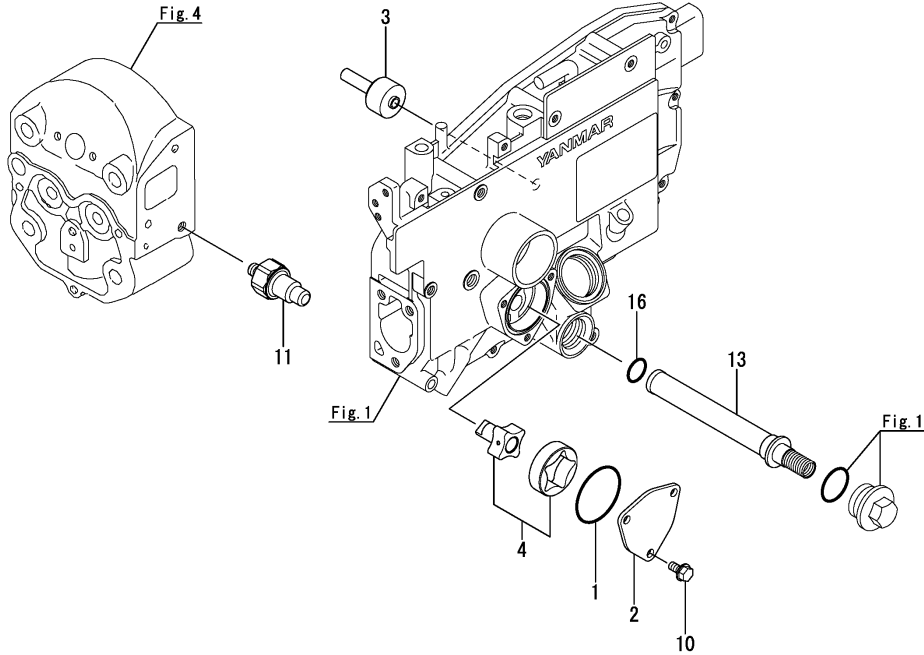
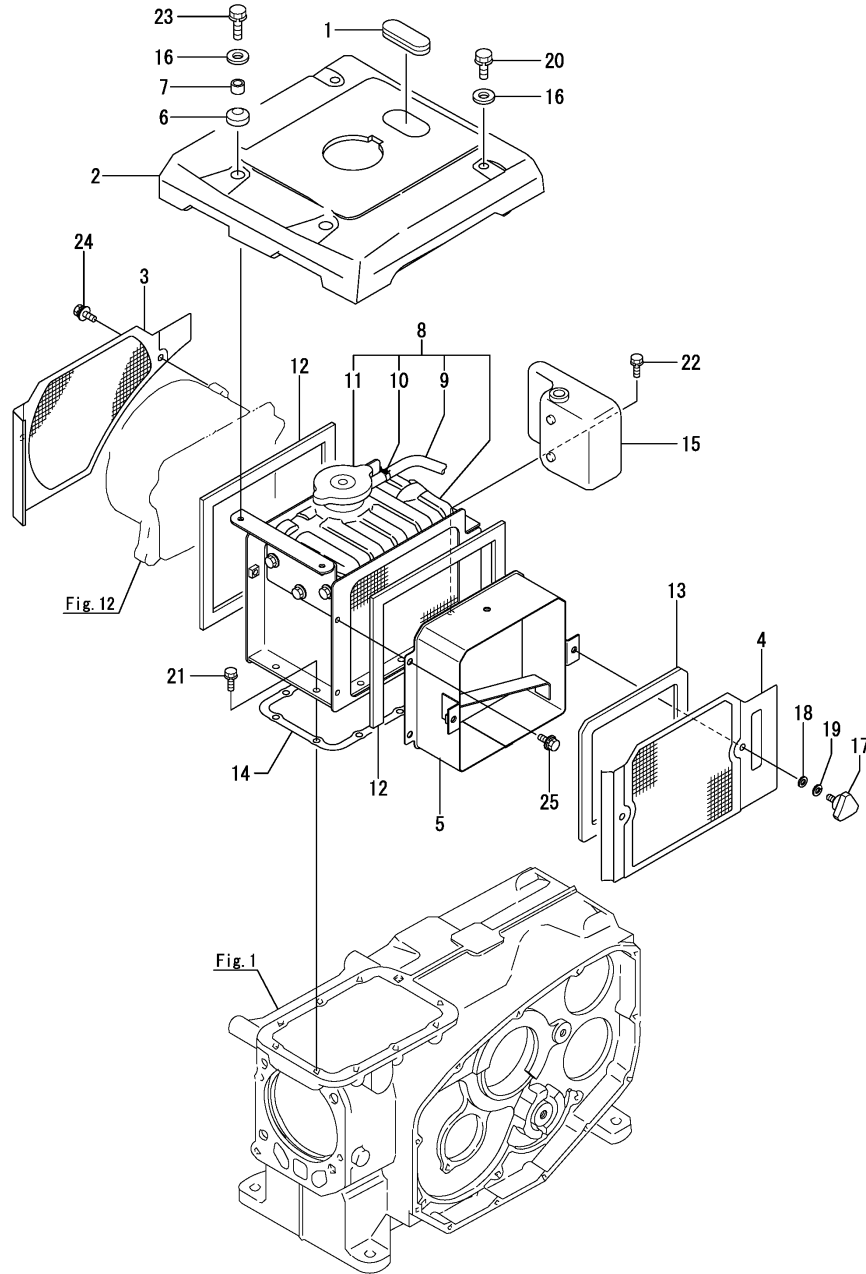

Fig.11. RADIATOR

(A)=TF090DIL
(B)=
(C)=

(D)=
(E)=
(F)=



No.	Lev.	Parts No.	Description	Q'ty						I	R
				(A)	(B)	(C)	(D)	(E)	(F)		
1	1	105300-44220	COVER, RADIATOR	1							
2	1	10540H-44250	COVER, RADIATOR	1							
3	1	10540H-44330	SCREEN	1							
4	1	10540H-44340	SCREEN	1							
5	1	10530H-44370	DUCT, SCREEN	1							
6	1	105300-44451	ABSORBER	2							
7	1	105300-44460	COLLAR	2							
8	1	10540H-44501	RADIATOR ASSY	1							
9	2	10530H-44570	PIPE, 7X205	1							
10	2	121250-44590	CLAMP, HOSE	1							
11	2	10530H-44600	CAP, RADIATOR	1							
12	1	104607-44540	SPONGE	2							
13	1	106100-44560	SPONGE, 15X5X1000	1							
14	1	10530H-44611	GASKET, RADIATOR	1							
15	1	10530H-44630	TANK, SUB	1							
16	1	10540H-76940	WASHER	4							
17	1	160725-78350	KNOB, BOLT M6X15	2							
18	1	22117-060000	WASHER, 6	2							
19	1	22217-060000	WASHER, SPRING 6	2							
20	1	26013-060142	BOLT, M6X 14	2							
21	1	26013-060162	BOLT, M6X 16	8							
22	1	26013-060182	BOLT, M6X 18	1							
23	1	26013-060182	BOLT, M6X 18	2							
24	1	26014-060142	BOLT, M6X 14	2							
25	1	26014-060142	BOLT, M6X 14	4							

Fig.12. FAN

(A)=TF090DIL
(B)=
(C)=

(D)=
(E)=
(F)=

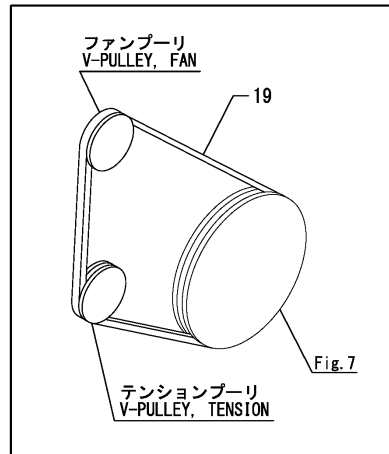
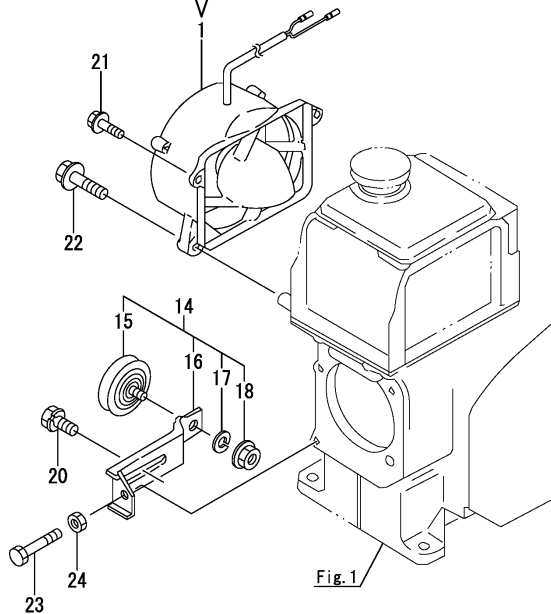
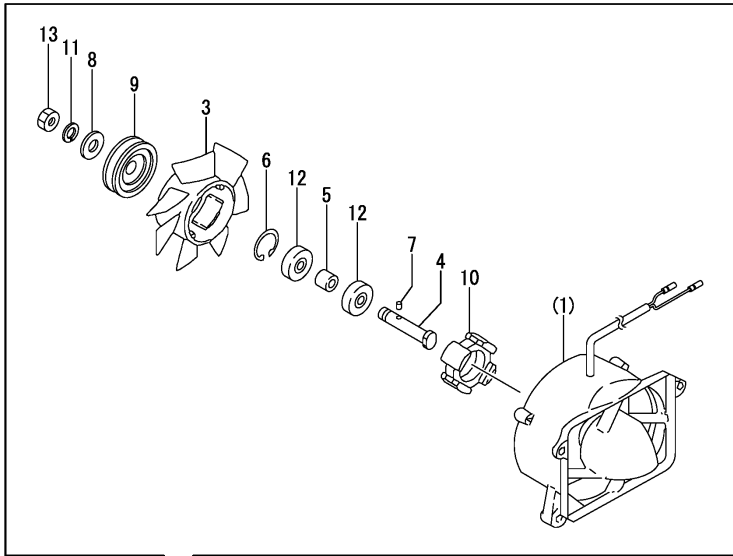

No.	Lev.	Parts No.	Description	Q'ty						I	R
				(A)	(B)	(C)	(D)	(E)	(F)		
1	1	10530H-44210	CASE ASSY, FAN	1							
3	2	10530H-44701	FAN	1							
4	2	105340-44701	SHAFT, FAN	1							
5	2	10530H-44720	COLLAR	1							
6	2	106383-44740	CIRCLIP	1							
7	2	105340-44750	PIN	1							
8	2	10530H-44760	WASHER	1							
9	2	10530H-44780	PULLEY, FAN	1							
10	2	10530H-78010	STATOR ASSY	1							
11	2	22217-120000	WASHER, SPRING 12	1							
12	2	24107-062013	BEARING, 6201ZZP6	2							
13	2	26777-120002	NUT, LOCK M12	1							
14	1	10530H-44810	PULLEY ASSY, TENSION	1							
15	2	10610H-44651	PULLEY, TENSION	1							
16	2	10530H-44941	LEVER, PULLEY	1							
17	2	22217-080000	WASHER, SPRING 8	1							
18	2	26366-080002	NUT, M8	1							
19	1	25117-003751	V-BELT, M37.5H	1							
20	1	26014-080162	BOLT, M8X 16	1							
21	1	26106-060202	BOLT, M6X 20 PLATED	2							
22	1	26106-080302	BOLT, M8X 30 PLATED	2							
23	1	26116-060504	BOLT, M6X 50 PLATED	1							
24	1	26756-060002	NUT, LOCK M6	1							

Fig.13. FUEL INJECTION PUMP

(A)=TF090DIL
(B)=
(C)=

(D)=
(E)=
(F)=

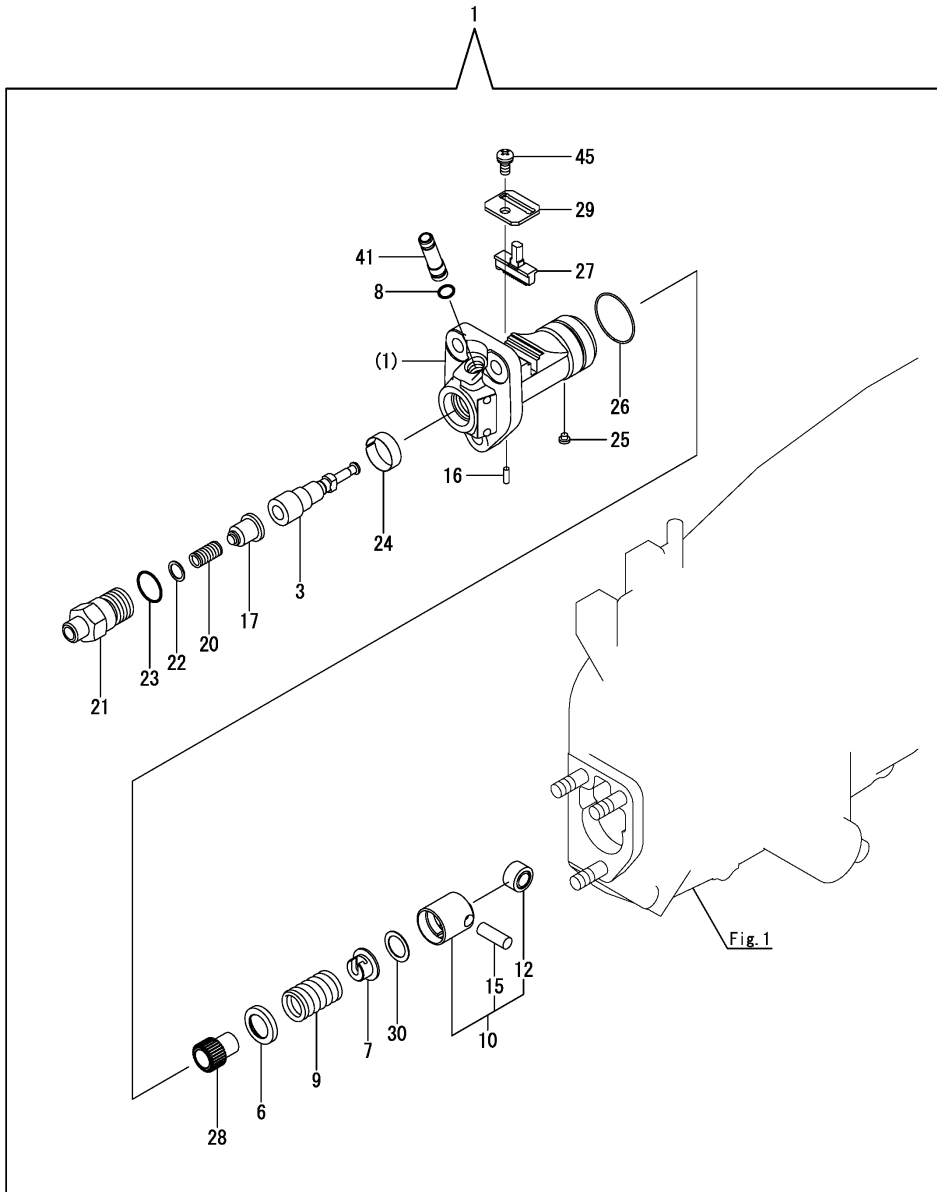

No.	Lev.	Parts No.	Description	Q'ty						I	R
				(A)	(B)	(C)	(D)	(E)	(F)		
1	1	705400-51102	PUMP ASSY, INJECTION	1							
3	2	105200-51100	PLUNGER ASSY	1							
6	2	158600-51170	RETAINER, SPRING	1							
7	2	174307-51181	RETAINER, SPRING B	1							
8	2	114250-51190	O-RING, S27	1							
9	2	124950-51190	SPRING, PLUNGER	1							
10	2	724550-51520	GUIDE, PLUNGER	1							
12	3	711100-51540	ROLLER ASSY	1							
15	3	174100-54120	PIN, TAPPET ROLLER	1							
16	2	103854-51251	PIN, PLUNGER	1							
17	2	129499-51300	VALVE ASSY, DELIVERY	1							
20	2	124550-51320	SPRING, DELIVERY	1							
21	2	124550-51341	HOLDER, DELIVERY L43	1							
22	2	124550-51350	GASKET, DELIVERY	1							
23	2	124550-51370	O-RING	1							
24	2	105300-51400	DEFLECTOR	1							
25	2	104271-51450	PIECE, GUIDE	1							
26	2	104271-51460	CIRCLIP	1							
27	2	105300-51500	RACK, CONTROL	1							
28	2	105300-51510	PINION	1							
29	2	105300-51550	RETAINER, RACK	1							
30	2	174307-51700	SHIM SET, PLUNGER	1							
41	2	105300-51800	JOINT	1							
45	2	26022-050102	SCREW, M5X10	1							

Fig.14. FUEL INJECTION DEVICE

(A)=TF090DIL
(B)=
(C)=

(D)=
(E)=
(F)=

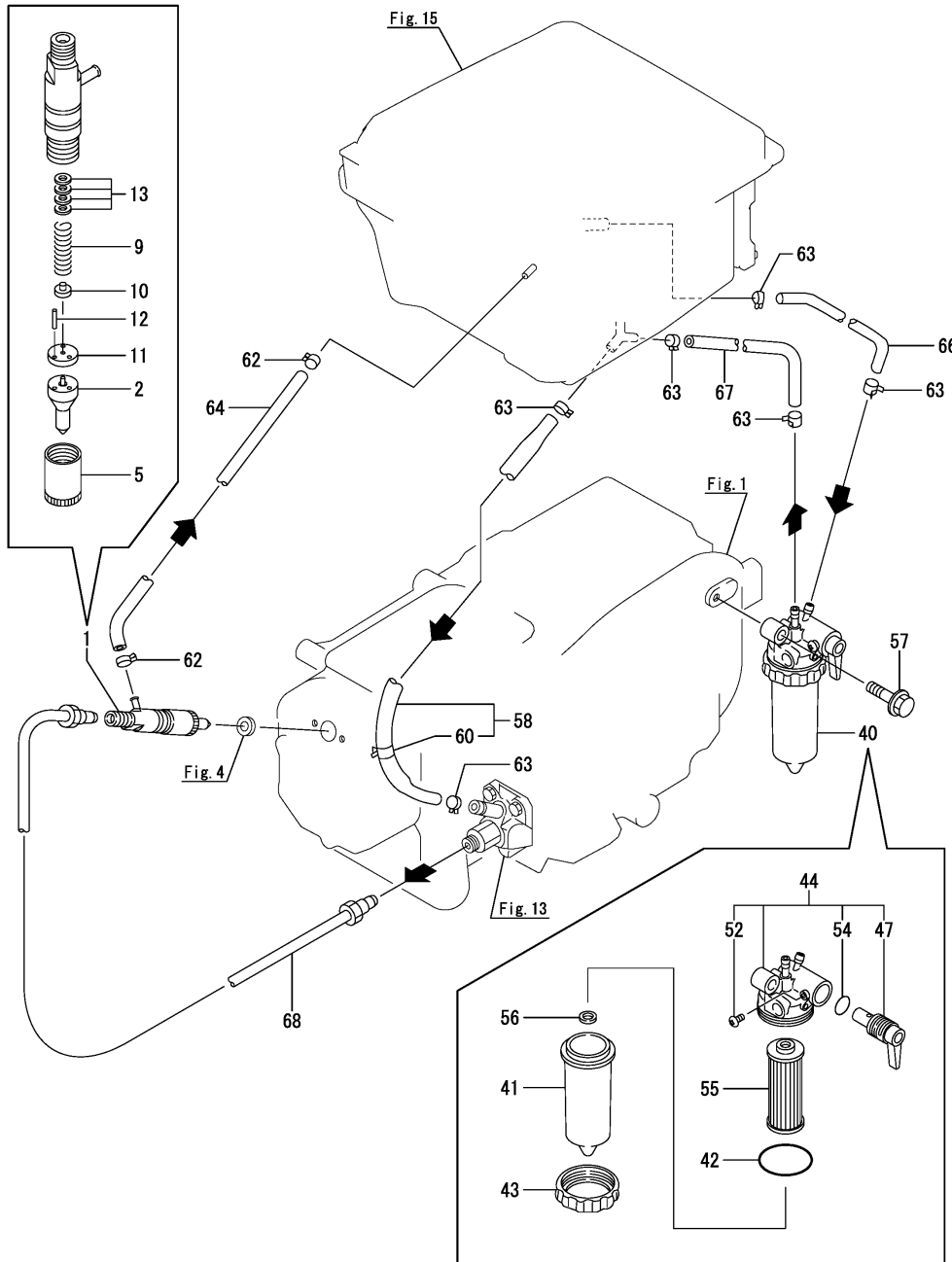

No.	Lev.	Parts No.	Description	Qty						I	R
				(A)	(B)	(C)	(D)	(E)	(F)		
1	1	705300-53100	VALVE ASSY,INJECTION	1							
2	2	129500-53050	NOZZLE ASSY, F.I.	1							
5	2	114250-53080	NUT, NOZZLE	1							
9	2	114250-53120	SPRING, NOZZLE	1							
10	2	114250-53130	SEAT, SPRING	1							
11	2	114250-53140	SPACER	1							
12	2	114250-53210	PIN	2							
13	2	119803-53400	SHIM SET	1							
40	1	105198-55600	STRAINER ASSY, FUEL	1							
41	2	105198-55510	CUP, STRAINER	1							
42	2	105300-55520	O-RING	1							
43	2	105300-55610	RING, RETAINING	1							
44	2	105300-55700	BODY ASSY, STRAINER	1							
47	3	105300-55340	LEVER	1							
52	3	104200-55750	SCREW, PAN M4	1							
54	3	24311-000160	O-RING, 1AP16.0	1							
55	2	105370-55711	ELEMENT	1							
56	2	105300-55750	FLOAT	1							
57	1	26106-080302	BOLT, M8X 30 PLATED	1							
58	1	10530H-59020	PIPE ASSY, FUEL OIL	1							
60	2	124766-59050	CLAMP, HOSE 11.5	1							
62	1	124722-59050	CLAMP, HOSE 9	2							
63	1	124766-59050	CLAMP, HOSE 11.5	6							
64	1	10530H-59100	RETURN TUBE, FUEL OIL	1							
66	1	10530H-59560	PIPE, FUEL OIL	1							
67	1	105300-59570	PIPE, FUEL	1							
68	1	10530H-59800	PIPE ASSY, INJECTION	1							

Fig.15. FUEL TANK

(A)=TF090DIL
(B)=
(C)=

(D)=
(E)=
(F)=

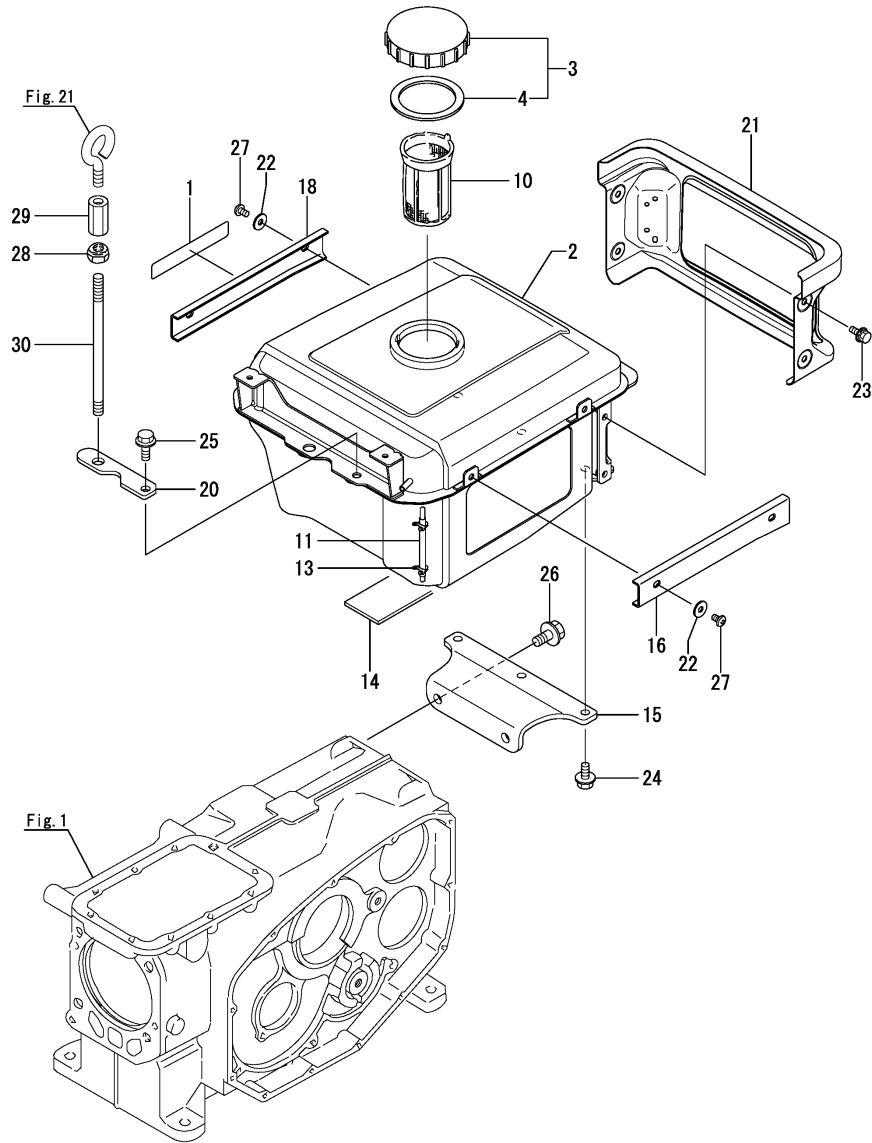

No.	Lev.	Parts No.	Description	Q'ty						I	R
				(A)	(B)	(C)	(D)	(E)	(F)		
1	1	10547H-07110	LABEL, ENGINE MODEL	1							
2	1	10540H-55040	TANK, FUEL OIL	1							
3	1	10547H-55050	CAP ASSY, FUEL TANK	1							
4	2	10530H-55050	GASKET	1							
10	1	101504-55101	STRAINER, FUEL	1							
11	1	104300-55160	GAUGE, LEVEL	1							
13	1	103854-55220	RETAINER	2							
14	1	104700-55220	FELT, FUEL TANK	1							
15	1	10540H-55240	STAY, FUEL TANK	1							
16	1	10547H-55300	GUARD, LINE(OFW	1							
18	1	10547H-55320	GUARD, LINE FW	1							
20	1	10530H-55520	RETAINER	1							
21	1	10530H-55830	COVER, LIGHT	1							
22	1	10540H-76940	WASHER	4							
23	1	26014-060142	BOLT, M6X 14	4							
24	1	26106-080162	BOLT, M8X 16 PLATED	3							
25	1	26106-080222	BOLT, M8X 22 PLATED	1							
26	1	26106-100202	BOLT, M10X 20 PLATED	2							
27	1	26557-060102	SCREW, M6X10	4							
28	1	104107-07900	NUT, M10	1							
29	1	10530H-07910	NUT, EYE BOLT	1							
30	1	10540H-07940	BOLT, ENGINE LIFT	1							

Fig.16. GOVERNOR & CONTROL EQUIPMENT

(A)=TF090DIL

(B)=

(C)=

(D)=

(E)=

(F)=

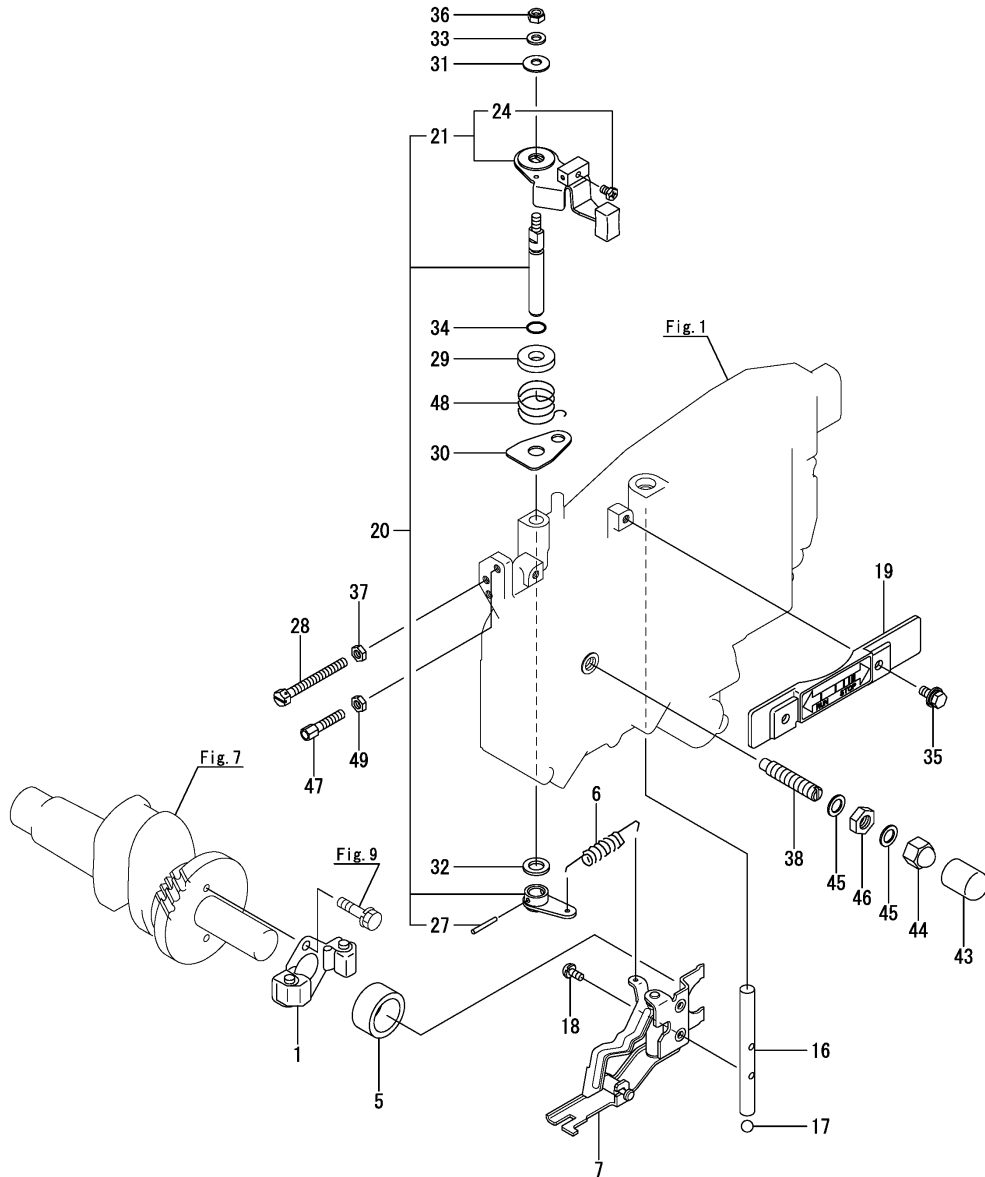

No.	Lev.	Parts No.	Description	Q'ty						I	R
				(A)	(B)	(C)	(D)	(E)	(F)		
1	1	705300-61701	GOVERNOR ASSY	1							
5	1	10530H-61600	SLEEVE, GOVERNOR	1							
6	1	10540H-66010	SPRING, REGULATOR	1							
7	1	105300-66310	LEVER ASSY, GOVERNOR	1							
16	1	105300-66400	SHAFT	1							
17	1	24190-120001	BALL, STEEL 3/8	1							
18	1	26022-050102	SCREW, M5X10	2							
19	1	10530H-66110	COVER, HANDLE	1							
20	1	10550H-66150	LEVER ASSY, HANDLE	1							
21	2	10550H-66040	HANDLE COMP,REGULATO	1							
24	3	10530H-66990	SCREW, INNER WIRE	1							
27	2	22322-030220	PIN, TAPER 3X22	1							
28	1	105300-66520	SCREW	1							
29	1	10530H-66830	PLATE, FRICTION	1							
30	1	10530H-66850	RETAINER	1							
31	1	10540H-66880	SPRING	1							
32	1	22117-100000	WASHER, 10	1							
33	1	22137-060000	WASHER, 6	1							
34	1	24311-000070	O-RING, 1AP7.0	1							
35	1	26014-060142	BOLT, M6X 14	2							
36	1	26347-060002	NUT, M6	1							
37	1	26756-060002	NUT, LOCK M6	1							
38	1	105500-66551	LIMITER ASSY, FUEL	1							
43	1	10530H-66610	CAP (F.O. LIMITTER)	1							
44	1	124060-66950	NUT, CAP M10	1							
45	1	22190-100002	WASHER, SEAL 10	2							
46	1	26796-100002	NUT, LOCK M10	1							
47	1	102100-67080	BOLT, ADJUST	1							
48	1	105502-67301	SPRING, RETURN	1							
49	1	26756-060002	NUT, LOCK M6	1							

Fig.17. STARTING DEVICE

(A)=TF090DIL
(B)=
(C)=

(D)=
(E)=
(F)=

No.	Lev.	Parts No.	Description	Q'ty						I	R
				(A)	(B)	(C)	(D)	(E)	(F)		
1	1	10530G-76330	GEAR, STARTING	1							
2	1	10530G-76330	GEAR, STARTING	1							
3	1	10570H-76340	SHAFT, STARTING	1							
4	1	10570H-76480	PIN, STARTING SHAFT	1							
5	1	105300-76470	COLLAR	1							
6	1	105300-76490	KEY, 7X10	1							
7	1	10570H-76790	HANDLE ASSY, START	1							
10	1	22242-000200	RING, 20	1							
11	1	10570H-08101	RETAINER, HANDLE	1							
12	1	10530G-08510	SPRING ASSY	1							
16	1	26106-060122	BOLT, M6X 12 PLATED	2							
17	1	26557-060102	SCREW, M6X10	1							

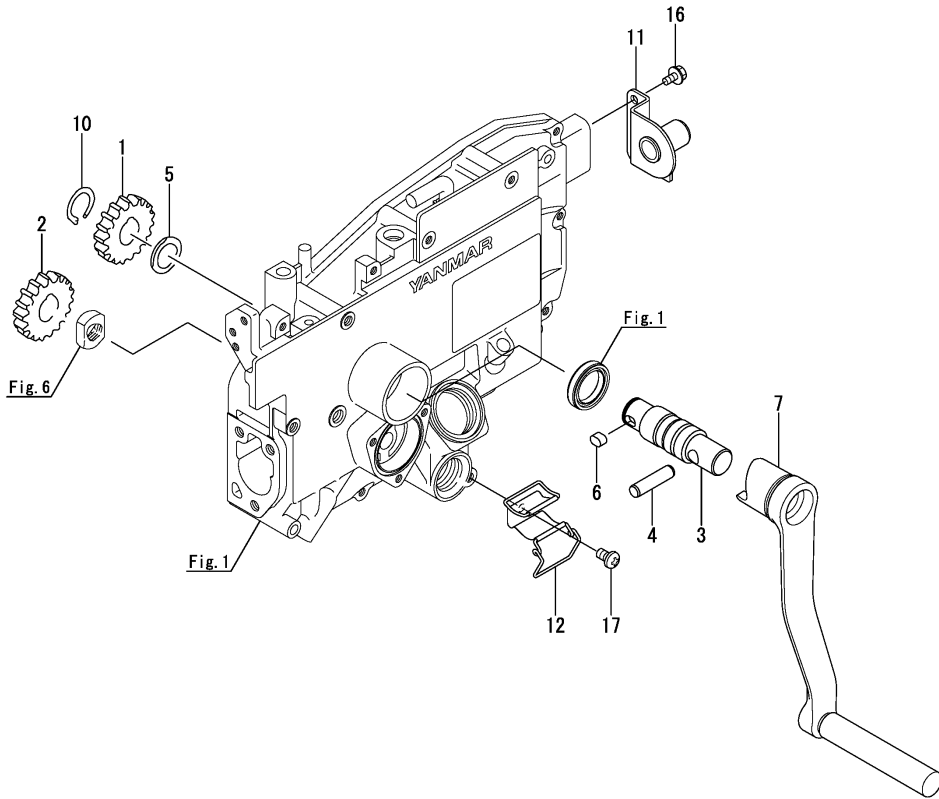
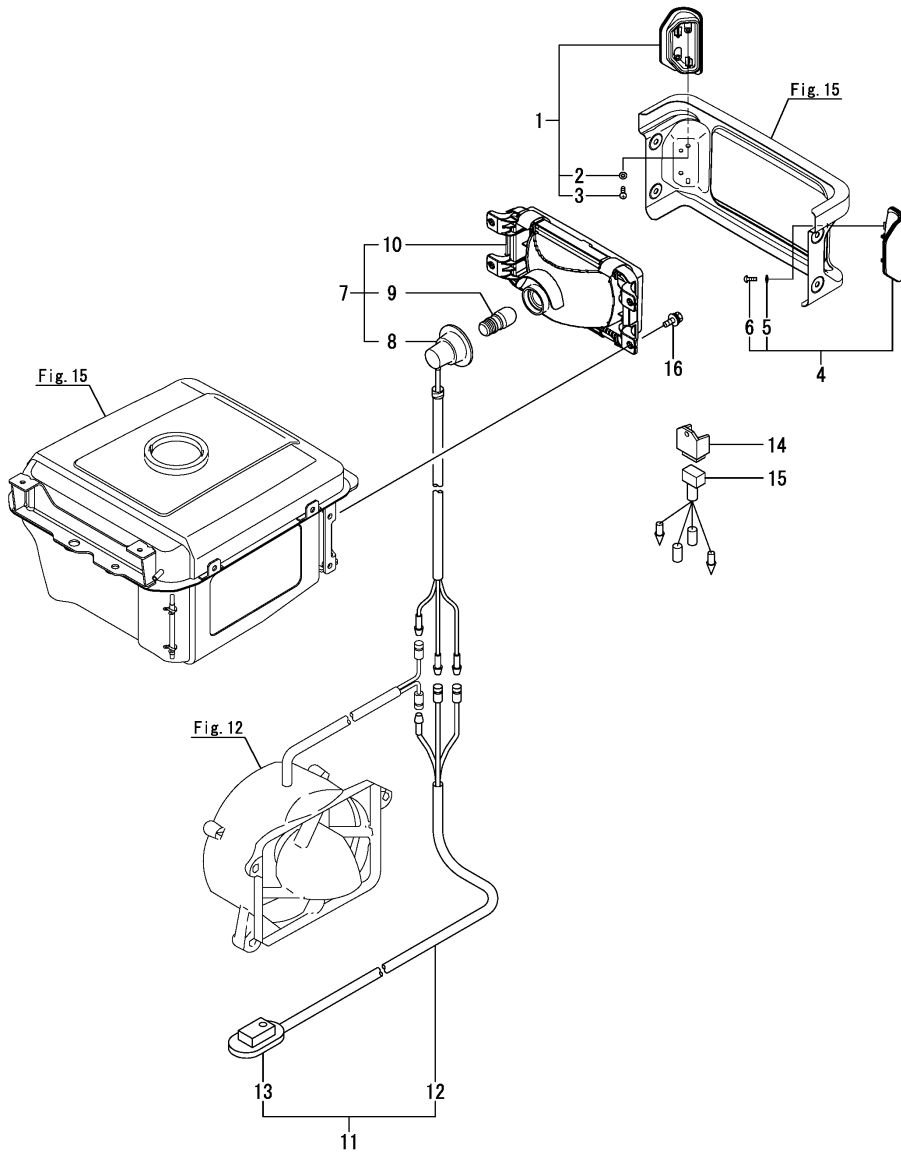

Fig.18. LAMP



(A)=TF090DIL
(B)=
(C)=

(D)=
(E)=
(F)=

No.	Lev.	Parts No.	Description	Q'ty						I	R
				(A)	(B)	(C)	(D)	(E)	(F)		
1	1	10530H-55450	REFLECTOR(R ASSY	1							
2	2	22137-040000	WASHER, 4	2							
3	2	22857-400160	SCREW, 4X16	2							
4	1	10530H-55460	REFLECTOR(L ASSY	1							
5	2	22137-040000	WASHER, 4	2							
6	2	22857-400160	SCREW, 4X16	2							
7	1	10530H-78030	LAMP ASSY	1							
8	2	10530H-78040	SOCKET ASSY	1							
9	2	10530H-78260	BULB, 32W	1							
10	2	10530H-78270	LAMP, UNIT	1							
11	1	10530H-78520	SWITCH ASSY, RIGHT	1							
12	2	10530H-78530	HARNESS, WIRE	1							
13	2	10530H-78960	SWITCH, LIGHT	1							
14	1	10530H-78540	REGULATOR	1							
15	1	10530H-78550	WIRE HARNESS	1							
16	1	26014-060162	BOLT, M6X 16	4							

Fig.19. LABEL

(A)=TF090DIL
(B)=
(C)=

(D)=
(E)=
(F)=

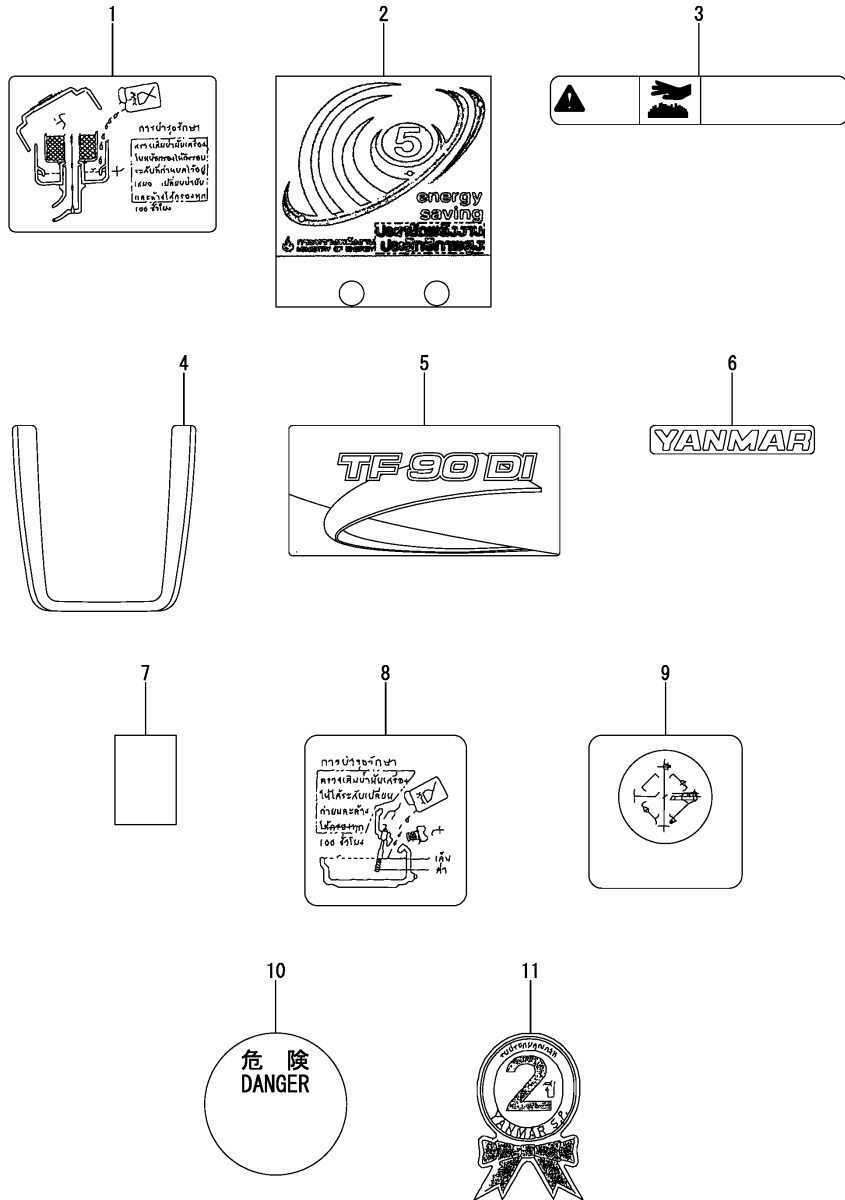

No.	Lev.	Parts No.	Description	Q'ty						I	R
				(A)	(B)	(C)	(D)	(E)	(F)		
1	1	10540H-07210	LABEL, AIR CLEANER	1							
2	1	10540H-07220	LABEL, ENERGY SAVING	1							
3	1	10537H-07330	LABEL, CAUTION	1							
4	1	10530H-07500	LABEL, STRIPE	1							
5	1	10540H-07520	LABEL, MODEL NAME	1							
6	1	10530H-07530	LABEL, YANMAR	1							
7	1	10540H-07640	LABEL, F.O. STRAINER	1							
8	1	10540H-07670	LABEL, CAUTION	1							
9	1	10530H-07720	LABEL, TIS MARK	1							
10	1	10530H-07750	LABEL, RADIATOR	1							
11	1	10530H-07781	LABEL, WARRANTY 2	1							

Fig.20. TOOL

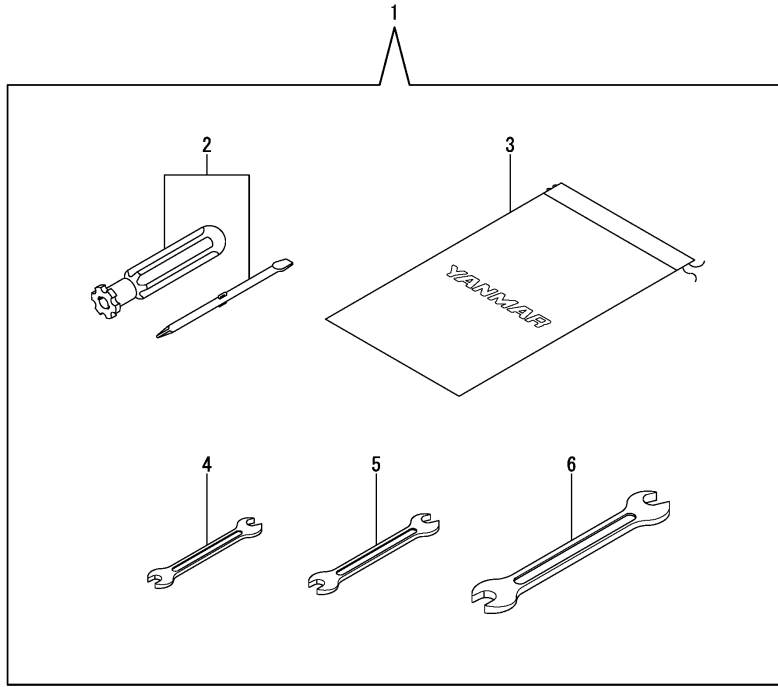

(A)=TF090DIL
(B)=
(C)=

(D)=
(E)=
(F)=

No.	Lev.	Parts No.	Description	Q'ty						I	R
				(A)	(B)	(C)	(D)	(E)	(F)		
1	1	10530H-92100	TOOL SET CMP	1							
2	2	104200-92350	SCREW-DRIVER	1							
3	2	10530G-92600	BAG, TOOL	1							
4	2	28110-100120	SPANNER, 10X12	1							
5	2	28110-140170	SPANNER, 14X17	1							
6	2	28110-190220	SPANNER, 19X22	1							

Fig.21. BUNDLED ITEMS

(A)=TF090DIL
(B)=
(C)=

(D)=
(E)=
(F)=

No.	Lev.	Parts No.	Description	Q'ty						I	R
				(A)	(B)	(C)	(D)	(E)	(F)		
1	1	10530H-92510	OIL, YANMAR GENUINE	1							
2	1	10540H-92701	COOLANT	1							
3	1	10547H-95711	CARD, MAINTENANCE	1							
4	1	10537H-97132	CARD, ACCESSORY	1							
5	1	22217-120000	WASHER, SPRING 12	3							
6	1	26206-120352	BOLT, M12X 35 PLATED	3							
7	1	26617-100002	BOLT, EYE M10	1							

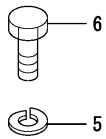
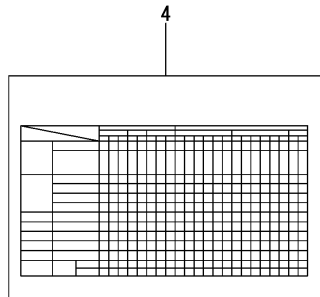
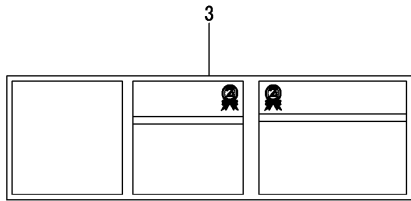
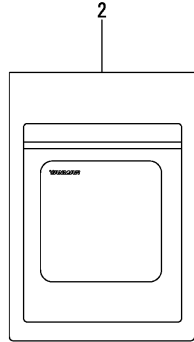
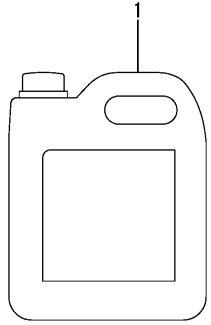

Parts No. Index

Parts No.	Fig. No.	Ref. No.
101158-03111	2	4
101158-11180	4	9
101158-11230	4	17
		21
101504-55101	15	10
102100-67080	16	47
103854-32051	10	1
103854-32082	10	2
103854-51251	13	16
103854-55220	15	13
104104-03750	4	35
104107-07900	15	28
104200-03641	4	37
104200-55750	14	52
104200-92350	20	2
104271-51450	13	25
104271-51460	13	26
104300-08050	3	2
104300-55160	15	11
104300-76460	6	10
104407-21600	7	12
104607-44540	11	12
104700-55220	15	14
105010-11920	4	26
105100-01660	1	18
105198-55510	14	41
105198-55600	14	40
105200-51100	13	3
105215-76490	9	12
105230-01200	1	9
105300-01333	1	11
105300-01410	1	24
105300-01690	1	27
105300-02020	7	19
105300-11100	4	6
105300-11111	4	7
105300-13201	5	20
105300-14090	6	3
105300-14700	6	9
105300-22300	8	8
105300-22400	8	9
105300-23200	8	13
105300-23500	8	10
105300-23910	8	17
105300-28251	9	1
105300-28380	9	5
105300-28450	9	7
105300-28700	9	8
105300-34040	1	20
105300-44220	11	1

Parts No.	Fig. No.	Ref. No.
105300-44451	11	6
105300-44460	11	7
105300-51400	13	24
105300-51500	13	27
105300-51510	13	28
105300-51550	13	29
105300-51800	13	41
105300-55340	14	47
105300-55520	14	42
105300-55610	14	43
105300-55700	14	44
105300-55750	14	56
105300-59570	14	67
105300-66310	16	7
105300-66400	16	16
105300-66520	16	28
105300-76470	17	5
105300-76490	17	6
105306-35052	10	13
10530G-08510	17	12
10530G-11650	4	32
10530G-28750	9	9
10530G-76330	17	1
		2
10530G-92600	20	3
10530H-01300	1	8
10530H-01481	1	25
10530H-01490	1	26
10530H-01800	1	29
10530H-01920	1	30
10530H-01950	1	31
10530H-01960	1	32
10530H-01970	1	33
10530H-02230	7	16
10530H-02300	7	20
10530H-02320	7	17
10530H-03070	2	1
10530H-03550	4	33
10530H-03610	4	34
10530H-07500	19	4
10530H-07530	19	6
10530H-07720	19	9
10530H-07750	19	10
10530H-07781	19	11
10530H-07910	15	29
10530H-08020	3	1
10530H-11270	4	10
10530H-11290	4	11
10530H-11310	4	41
10530H-11650	4	15

Parts No.	Fig. No.	Ref. No.
10530H-11660	4	19
10530H-11900	4	25
10530H-12851	5	13
10530H-12860	5	14
10530H-13570	5	29
10530H-14200	6	6
10530H-14400	6	7
10530H-14600	6	8
10530H-21100	7	5
10530H-21530	7	11
10530H-32200	10	3
10530H-34850	1	43
10530H-44210	12	1
10530H-44370	11	5
10530H-44570	11	9
10530H-44600	11	11
10530H-44611	11	14
10530H-44630	11	15
10530H-44701	12	3
10530H-44720	12	5
10530H-44760	12	8
10530H-44780	12	9
10530H-44810	12	14
10530H-44941	12	16
10530H-55050	15	4
10530H-55450	18	1
10530H-55460	18	4
10530H-55520	15	20
10530H-55830	15	21
10530H-59020	14	58
10530H-59100	14	64
10530H-59560	14	66
10530H-59800	14	68
10530H-61600	16	5
10530H-66110	16	19
10530H-66610	16	43
10530H-66830	16	29
10530H-66850	16	30
10530H-66990	16	24
10530H-78010	12	10
10530H-78030	18	7
10530H-78040	18	8
10530H-78260	18	9
10530H-78270	18	10
10530H-78520	18	11
10530H-78530	18	12
10530H-78540	18	14
10530H-78550	18	15
10530H-78960	18	13
10530H-92100	20	1

Parts No.	Fig. No.	Ref. No.
10530H-92510	21	1
105340-44701	12	4
105340-44750	12	7
105362-78960	2	5
105370-55711	14	55
10537H-01220	1	10
10537H-03060	2	2
10537H-07330	19	3
10537H-11120	4	8
10537H-14010	6	1
10537H-14190	6	5
10537H-21290	7	7
10537H-21520	7	8
10537H-32500	10	4
10537H-97132	21	4
105400-01560	1	1
105400-11015	4	1
105400-11800	4	44
105400-12050	5	2
10540G-28300	9	3
10540G-28310	9	4
10540H-01390	1	12
10540H-01751	1	28
10540H-01900	1	5
10540H-02310	7	21
10540H-02500	7	14
10540H-07210	19	1
10540H-07220	19	2
10540H-07520	19	5
10540H-07640	19	7
10540H-07670	19	8
10540H-07940	15	30
10540H-12031	5	1
10540H-12510	5	3
10540H-12550	5	15
10540H-12700	5	4
10540H-12750	5	6
10540H-12800	5	7
10540H-13512	5	21
10540H-14100	6	4
10540H-21200	7	9
10540H-21400	7	10
10540H-21700	7	1
10540H-28410	9	6
10540H-44250	11	2
10540H-44330	11	3
10540H-44340	11	4
10540H-44501	11	8
10540H-55040	15	2
10540H-55240	15	15

Parts No. Index

Parts No.	Fig. No.	Ref. No.
10540H-66010	16	6
10540H-66880	16	31
10540H-76940	11	16
	15	22
10540H-92701	21	2
105430-28720	9	10
10547H-07110	15	1
10547H-22190	8	1
10547H-22500	8	3
10547H-55050	15	3
10547H-55300	15	16
10547H-55320	15	18
10547H-95711	21	3
105500-03130	2	7
105500-66551	16	38
105502-67301	16	48
10550H-66040	16	21
10550H-66150	16	20
105582-34100	10	11
10570H-08101	17	11
10570H-12710	5	5
10570H-76340	17	3
10570H-76480	17	4
10570H-76790	17	7
10571H-61250	1	23
106100-21130	7	6
106100-44560	11	13
10610H-44651	12	15
106383-44740	12	6
114250-51190	13	8
114250-53080	14	5
114250-53120	14	9
114250-53130	14	10
114250-53140	14	11
114250-53210	14	12
119625-11871	4	23
119625-11880	4	24
119803-53400	14	13
121250-44590	11	10
123672-83880	9	13
124060-66950	16	44
124550-51320	13	20
124550-51341	13	21
124550-51350	13	22
124550-51370	13	23
124722-59050	14	62
124766-59050	14	60
		63
124950-51190	13	9
128170-11340	4	14

Parts No.	Fig. No.	Ref. No.
129499-51300	13	17
129500-53050	14	2
158600-51170	13	6
160725-78350	11	17
174100-54120	13	15
174307-51181	13	7
174307-51700	13	30
22117-060000	11	18
22117-100000	16	32
22137-040000	18	2
		5
22137-060000	16	33
22190-100002	16	45
22217-040000	2	6
22217-060000	11	19
22217-080000	5	30
	12	17
22217-120000	3	3
	12	11
	21	5
22242-000200	17	10
22242-000450	7	22
22252-000100	1	21
22312-030180	4	39
22322-030160	4	36
22322-030220	16	27
22351-060012	1	4
		19
	4	5
22857-400160	18	3
		6
23064-090330	2	8
24101-060054	9	14
24101-060064	6	11
24101-060084	9	15
24107-062013	12	12
24190-120001	1	22
	16	17
24311-000060	1	34
24311-000070	4	40
	16	34
24311-000160	14	54
24311-000320	1	35
24321-000250	1	36
24321-000450	5	16
24341-000200	10	16
25117-003751	12	19
26013-060142	11	20
26013-060162	11	21
26013-060182	11	22

Parts No.	Fig. No.	Ref. No.
26013-060182	11	23
26013-060222	9	16
26013-080202	7	23
26014-060142	11	24
		25
		25
	15	23
	16	35
26014-060162	18	16
26014-080162	12	20
26022-050102	13	45
	16	18
26022-060122	6	12
26106-060122	7	13
	10	10
	17	16
26106-060142	1	37
26106-060202	4	42
	12	21
26106-060222	2	9
26106-060252	1	38
26106-060602	4	43
26106-060652	1	39
26106-080142	9	17
26106-080162	15	24
26106-080202	5	17
26106-080222	15	25
26106-080302	12	22
	14	57
26106-080602	5	18
26106-100202	15	26
26106-100552	9	18
26116-060102	7	18
26116-060504	12	23
26206-120352	21	6
26216-060302	4	27
26216-080202	5	31
26216-080222	1	40
26347-060002	16	36
26366-060002	1	41
	4	28
26366-080002	1	42
	4	29
	5	32
	12	18
26557-060102	15	27
	17	17
26557-060202	5	33
26587-080122	6	13
26617-100002	21	7
26636-080002	5	19

Parts No.	Fig. No.	Ref. No.
26706-120002	3	4
26756-060002	12	24
	16	37
		49
26756-080002	4	18
		22
26777-120002	12	13
26796-100002	16	46
27310-070001	4	30
28110-100120	20	4
28110-140170	20	5
28110-190220	20	6
705300-23600	8	15
705300-23610	8	18
705300-23620	8	20
705300-53100	14	1
705300-61701	16	1
705400-51102	13	1
711100-51540	13	12
724550-51520	13	10