

0CB10-M62003EN

## Directions for the Parts Catalog.

1. This Parts Catalog shows both standard and optional parts.
2. Parts may change without prior notice.
3. The following is an example of the Parts Catalog format.

REF.	LEV.	PARTS NO.	DESCRIPTION	Q'TY						I	R
				(A)	(B)	(C)	(D)	(E)	(F)		
1	1	729595-51390	FUEL INJECTION PUMP	1	1	1	1	1			1
1-1	1	729595-51391	FUEL INJECTION PUMP	1	1	1	1	1		N	1
		(A=E00185) (B=E00200)									
3	2	26022-060162	SCREW M 6X 16	9	9	9	9	9			
3-1	2	26022-060162	SCREW M 6X 16	4	4	4	4	4		K	
		(A=E00156) (B=E00156) (C=E00156) (D=E00156) (E=E00156)									
4	2	129470-51040	CAMSHAFT	1	1	1	1	1			
5	2	122710-51050	BEARING, ROLLER	2	2	2	2	2			
6	2	129470-51060	RETAINER	1	1	1	1	1			

Remarks
(1) BOOST COMPEMSATOR TYPE. OPTIONAL PART, TO E00155,(4JH-DT, 4JH-DTZ

### ① Ref. No.

The Ref. No. listed may not be in accordance with the illustration Ref. No.

(Ex.) Illustration No.

List Ref No.

1

1

(Before change)

1-1

(After change)

For interchangeable symbols N, R and K, illustrations for new parts may be abbreviated.

### ② Lev. (Level)

Level indication

The numbers below indicate the level of relativity towards the main part.

1 ----- Main parts (Assembly parts)

2 ----- Sub component included in " 1 ".

3 ----- Sub component included in " 2 ".

Note) Parts that are not for sale are partially illustrated but not listed.

### ③ Interchangeability Symbol

When a part change takes place, one of the following interchangeability symbols is indicated beside the part.

Symbol	Interchangeability	Contents note
N	Old $\begin{matrix} \leftarrow \text{Yes} \\ \text{No} \rightarrow \end{matrix}$ New	New Part is interchangeable for Old Part but Old Part is not interchangeable for New Part.
Q	Old $\begin{matrix} \leftarrow \text{No} \\ \text{Yes} \rightarrow \end{matrix}$ New	New Part is not interchangeable for Old Part but Old Part is interchangeable for New Part.
R	Old $\begin{matrix} \leftarrow \text{Yes} \\ \text{Yes} \rightarrow \end{matrix}$ New	New/ Old Parts are both interchangeable.
S	Old $\begin{matrix} \leftarrow \text{No} \\ \text{No} \rightarrow \end{matrix}$ New	New/ Old Parts are both not interchangeable.
W		Part newly added.
Z		Part discontinued.
F		Not interchangeable by a single part but interchangeable together with related parts.
K		Changes only for used parts quantities.

### ④ Effective Machine No.

When a part changes, the effective Machine No. will be indicated in the (A)-(F) column.

Product Symbol	Product No.	Product Symbol	Product No.
C	Clutch No. Compressor No.	F	Machine No. (Agricultural Equip.)
D	Drive No.	M	Machine No.
E	Engine No.		

Note 1) A date may follow the symbol. (Ex.) 1996.01

Note 2) "XXXXX" and "ZZZZZ" are for parts that could not be predicted or for engine models that could not be identified.

Note 3) (A=E00185) is the E (Engine Serial Number) for the column (A) model (in this case 4JH-DT) after the parts design change.

### ⑤ Remarks

Figures or alphabets (symbols) are entered in the remarks column.

The comments (remarks) on parts that are indicated at the bottom of the illustration are the same symbols as those stated above.

# Contents

OCB10-M62003

Fig. No.	Fig. Name	Fig. No.	Fig. Name
ENGINE 3TNE84(T)-(E)KAH			
1.	CYLINDER BLOCK		
2.	GEAR HOUSING		
3.	MOUNTING FLANGE & OIL SUMP		
4.	CYLINDER HEAD & BONNET		
5.	CYLINDER HEAD & BONNET		
6.	SUCTION MANIFOLD		
7.	EXHAUUST MANIFOLD		
8.	TURBOCHAEGER		
9.	CAMSHAFT & DRIVING GEAR		
10.	CRANKSHAFT & PISTON		
11.	LUB.OIL SYSTEM		
12.	LUB.OIL PIPE		
13.	COOLING WATER SYSTEM		
14.	FUEL INJECTION PUMP		
15.	GOVERNOR		
16.	FUEL INJECTION VALVE		
17.	STARTING MOTOR		
18.	GENERATOR		
19.	GASKET SET & T00LS		

Fig.1. CYLINDER BLOCK

(A)=3TNE84-KAH  
(B)=3TNE84T-KAH  
(C)=3TNE84-EKAH

(D)=3TNE84T-EKAH  
(E)=  
(F)=

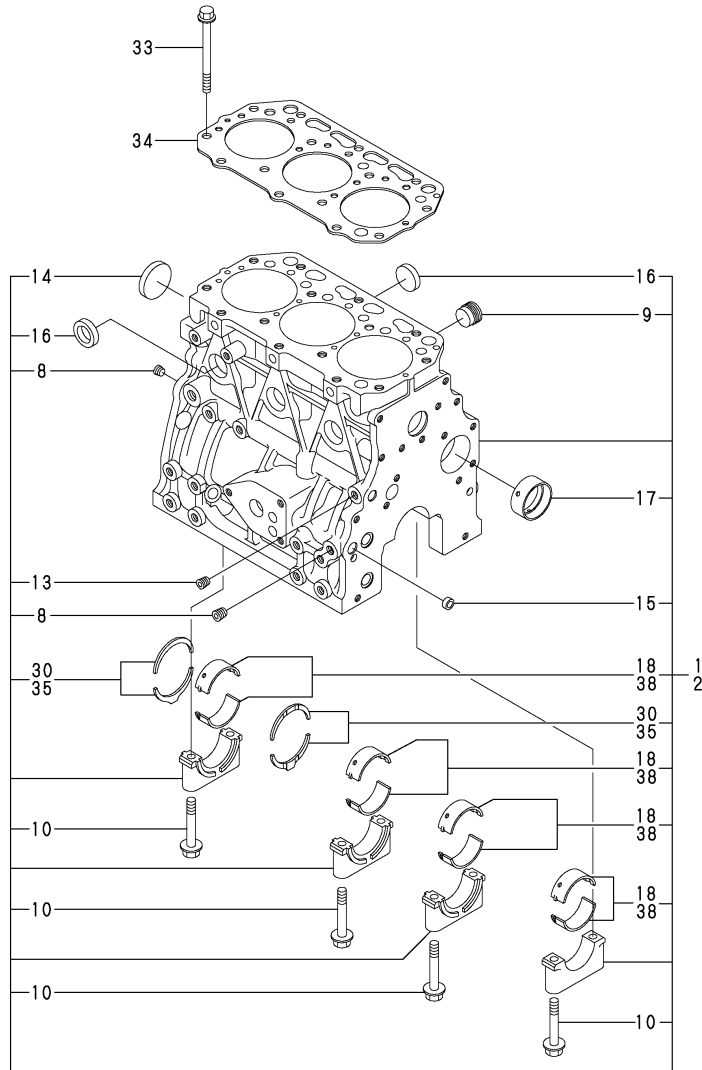

No.	Lev.	Parts No.	Description	Q'ty						I	R
				(A)	(B)	(C)	(D)	(E)	(F)		
1	1	729002-01560	BLOCK ASSY, CYLINDER	1		1					
2	1	729012-01560	BLOCK ASSY, CYLINDER		1			1			
8	3	124160-01910	PLUG, PT1/4	3	3	3	3				
9	3	171051-01921	PLUG, NPTF1	1	1	1	1				
10	3	129150-02020	BOLT, METAL CAP	8	8	8	8				
13	3	23871-010000	PLUG, R01	1	1						
13-1	3	23876-010000	PLUG, R01	1	1	1	1				N
		(A=E/#43125) (B=E/#46340)									
14	3	27231-500000	PLUG 50	1	1	1	1				
14-1	3	129001-01250	PLUG, 50	1	1	1	1				N
		(A=E/#43125) (B=E/#46340) (C=E/#51224) (D=E/#50846)									
15	3	27241-120000	PLUG, 12	2	2	2	2				
16	3	27241-300000	PLUG 30	6	6	6	6				
17	3	129795-02411	BUSH, CAMSHAFT	1	1	1	1				
18	2	129001-02930	BEARING, MAIN	4	4	4	4				
30	2	129150-02930	BEARING, THRUST	2	2	2	2				
33	1	129150-01200	BOLT, HEAD	14	14	14	14				
34	1	129002-01331	GASKET, HEAD	1	1	1	1				
35	1	129150-02940	BEARING, THRUST 0.25	2	2	2	2				1
38	1	129150-02870	BEARING, 0.25 US	4	4	4	4				2

Remarks

- (1)OVER SIZED(O.S.=0.25)PART.
- (2)UNDER SIZED(U.S.=0.25)PART.

Fig.2. GEAR HOUSING

(A)=3TNE84-KAH  
(B)=3TNE84T-KAH  
(C)=3TNE84-EKAH

(D)=3TNE84T-EKAH  
(E)=  
(F)=

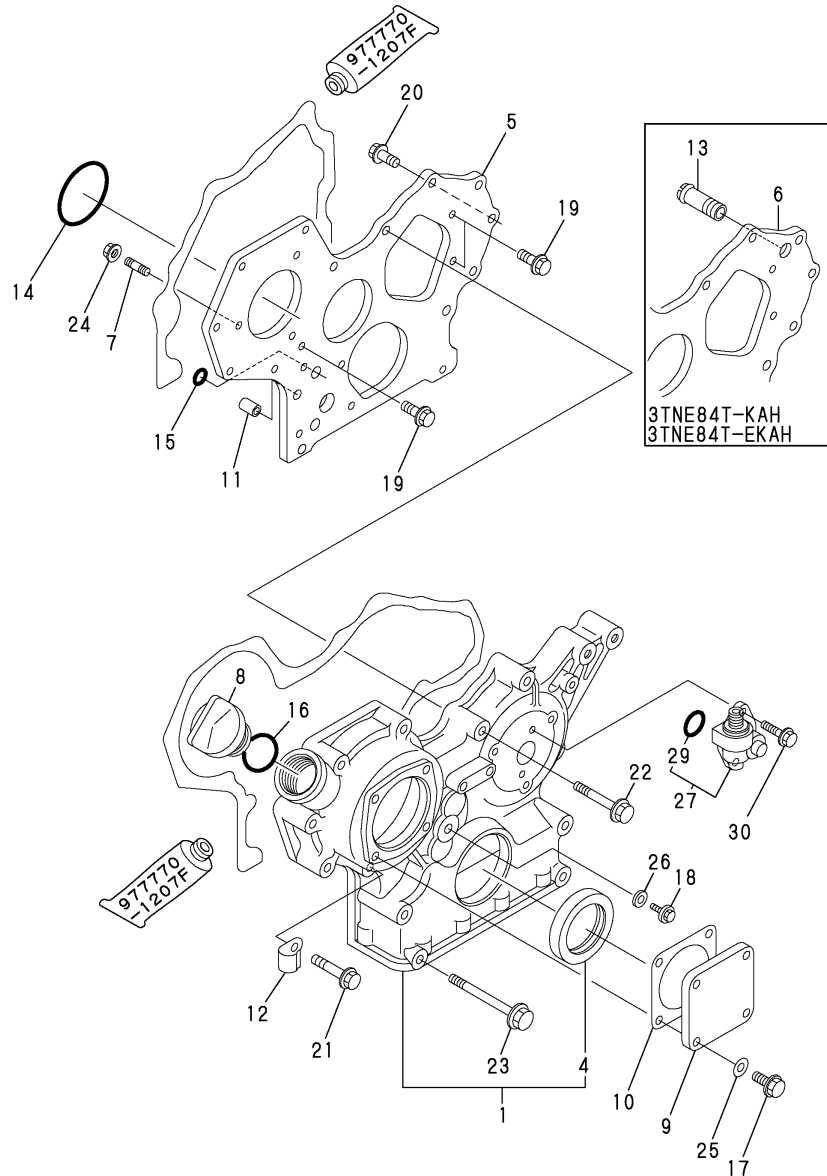

No.	Lev.	Parts No.	Description	Qty						I	R
				(A)	(B)	(C)	(D)	(E)	(F)		
1	1	719810-01500	CASE ASSY, GEAR	1	1	1	1				
4	2	129795-01800	SEAL, OIL	1	1	1	1				
5	1	129400-01520	FLANGE, GEAR CASE	1		1					
6	1	129103-01530	FLANGE, GEAR CASE		1		1				
7	1	121450-01560	STUD, M8X22	3	3	3	3				
8	1	124160-01751	COVER, FILLER	1	1	1	1				
9	1	124240-01871	COVER	1	1	1	1				
10	1	124240-01883	GASKET	1	1	1	1				
11	1	129795-01950	PIPE, KNOCK L=18	2	2	2	2				
12	1	129150-03100	RETAINER, PIPE	1	1	1	1				
13	1	129122-44480	JOINT		1		1				
14	1	121850-51960	O-RING	1	1	1	1				
15	1	24311-000160	O-RING, 1AP16.0	2	2	2	2				
15-1	1	119609-32040	O-RING, P16	2	2	2	2				R
		(A=E/#43125)	(B=E/#46340)	(C=E/#65495)	(D=E/#65482)						
16	1	24311-000320	O-RING, 1AP32.0	1	1	1	1				
17	1	26106-080122	BOLT, M8X 12 PLATED	4	4	4	4				
18	1	26106-080162	BOLT, M8X 16 PLATED	1	1	1	1				
19	1	26106-080162	BOLT, M8X 16 PLATED	3		3					
20	1	26106-080202	BOLT, M8X 20 PLATED	2	2	2	2				
21	1	26106-080452	BOLT, M8X 45 PLATED	6	6	6	6				
22	1	26106-080552	BOLT, M8X 55 PLATED	3	3	3	3				
23	1	129001-91840	BOLT, M8X85	4	4	4	4				
23-1	1	129001-91841	BOLT, M8X85	4	4	4	4				R
		(A=E/#43125)	(B=E/#46340)	(C=E/#54080)	(D=E/#54114)						
24	1	26366-080002	NUT, M8	3	3	3	3				
24-1	1	26306-080002	NUT, M8	3	3	3	3				R
		(A=E/#43125)	(B=E/#46340)	(C=E/#63670)	(D=E/#63398)						
25	1	22190-080002	WASHER, SEAL 6	4	4	4	4				
26	1	22190-080002	WASHER, SEAL 6	1		1					
27	1	129150-91400	GEAR	1	1	1	1				
29	2	24341-000240	O-RING, 1AS24.0	1	1	1	1				
30	1	26106-060162	BOLT, M6X 16 PLATED	2	2	2	2				

Fig.3. MOUNTING FLANGE & OIL SUMP

(A)=3TNE84-KAH  
(B)=3TNE84T-KAH  
(C)=3TNE84-EKAH

(D)=3TNE84T-EKAH  
(E)=  
(F)=

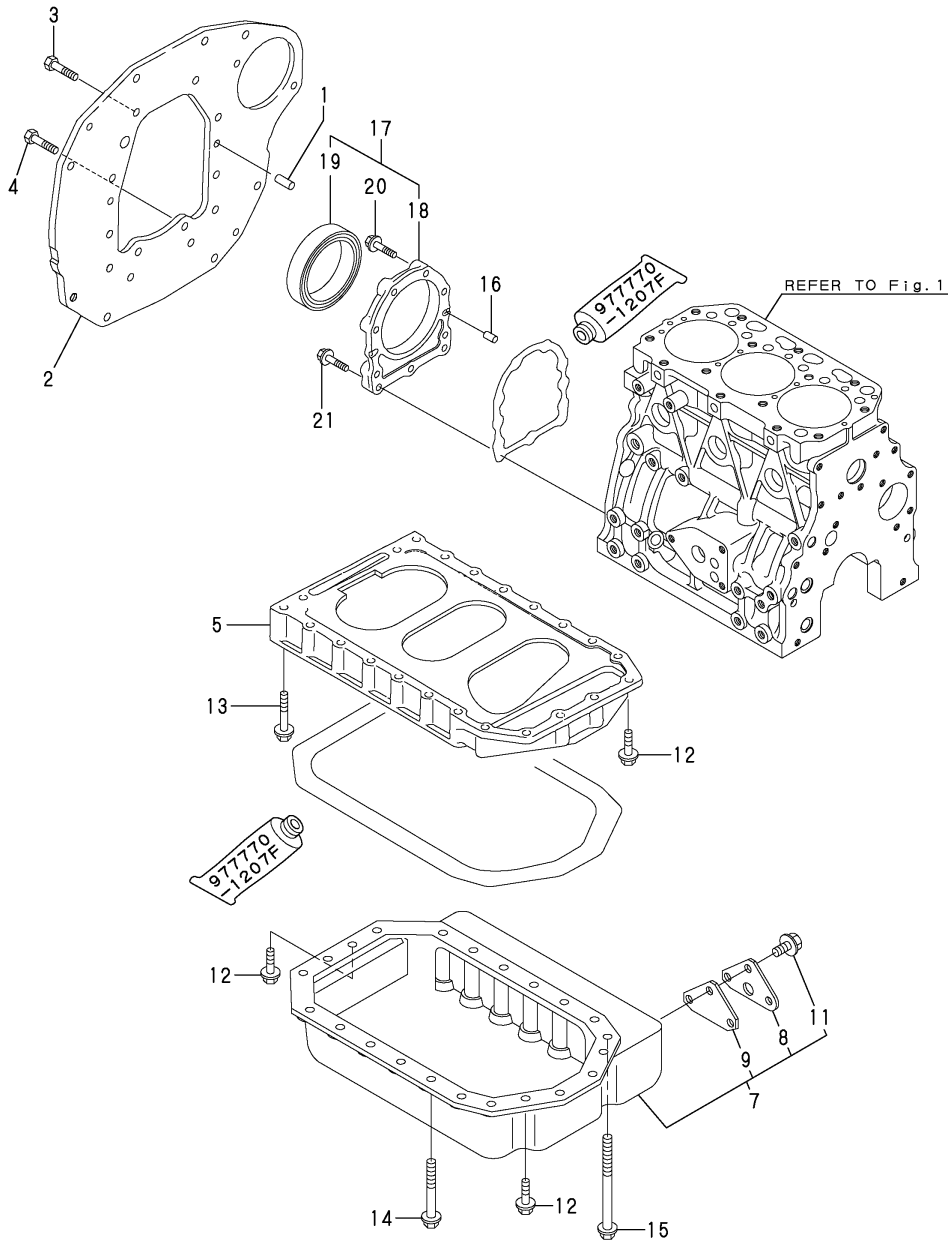

No.	Lev.	Parts No.	Description	Q'ty						I	R
				(A)	(B)	(C)	(D)	(E)	(F)		
1	1	129100-01580	PIN, M8X16	2	2	2	2				
2	1	129150-01600	FLANGE, MOUNTING	1	1	1	1				
3	1	26206-100202	BOLT, M10X 20 PLATED	6	6	6	6				
4	1	26206-100252	BOLT, M10X 25 PLATED	4	4	4	4				
5	1	129100-01730	SPACER, OIL SUMP	1	1	1	1				
7	1	129135-01770	SUMP ASSY, OIL	1	1	1	1				
8	2	171058-01630	COVER	1	1	1	1				
9	2	171058-01640	GASKET	1	1	1	1				
9-1	2	171058-01641	GASKET	1	1	1	1				N
		(A=E/#43125)	(B=E/#46340)	(C=E/#78449)	(D=E/#78826)						
11	2	26106-080162	BOLT, M8X 16 PLATED	3	3	3	3				
12	1	26106-080252	BOLT, M8X 25 PLATED	6	6	6	6				
13	1	26106-080452	BOLT, M8X 45 PLATED	2	2	2	2				
14	1	26106-080602	BOLT, M8X 60 PLATED	11	11	11	11				
15	1	129001-91870	BOLT, M8X100	7	7	7	7				
16	1	129100-01580	PIN, M8X16	2	2	2	2				
17	1	129100-01640	CASE ASSY, OIL SEAL	1	1	1	1				
18	2	129150-01650	CASE, OIL SEAL	1	1	1	1				
19	2	129795-01780	SEAL, OIL	1	1	1	1				
20	1	129486-01670	BOLT, M8X30	6	6	6	6				
21	1	26106-080352	BOLT, M8X 35 PLATED	3	3	3	3				

Fig.4. CYLINDER HEAD & BONNET

(A)=3TNE84-KAH  
(B)=3TNE84T-KAH  
(C)=3TNE84-EKAH

(D)=3TNE84T-EKAH  
(E)=  
(F)=

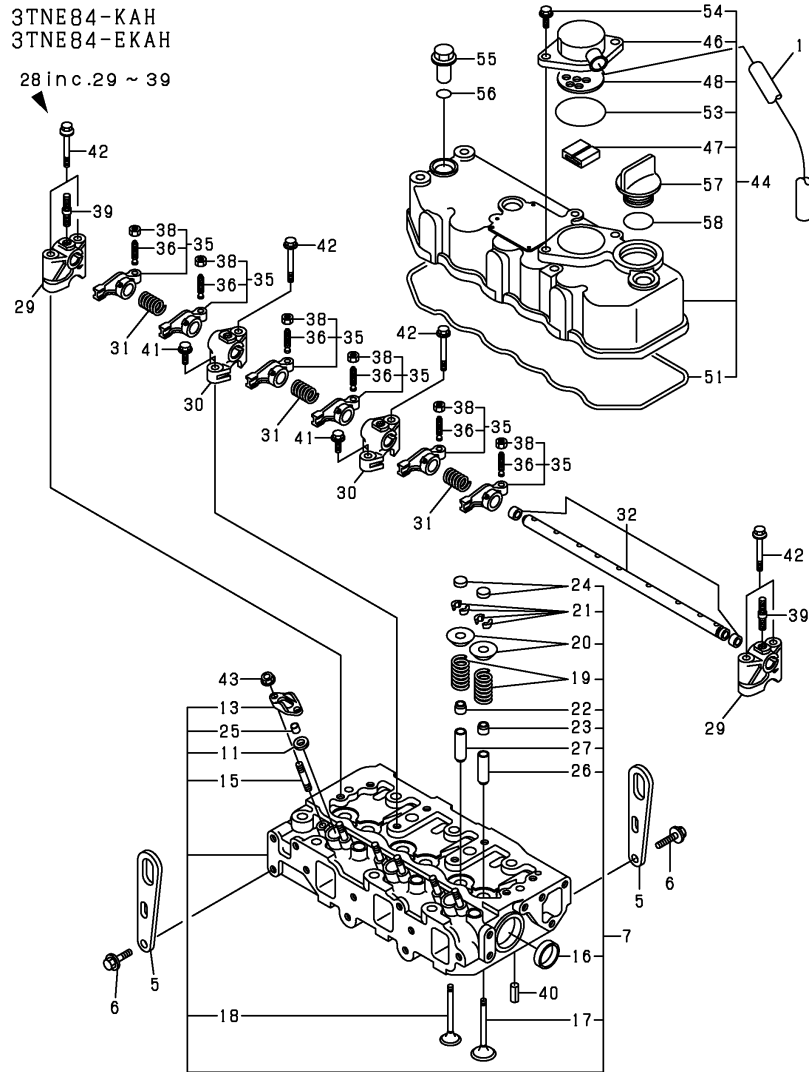

No.	Lev.	Parts No.	Description	Q'ty						I	R
				(A)	(B)	(C)	(D)	(E)	(F)		
1	1	129150-03090	HOSE, ID16X2T	1		1					
5	1	124736-07900	LIFTER	2		2					
6	1	26106-080142	BOLT, M8X 14 PLATED	4		4					
7	1	129001-11700	HEAD ASSY, CYLINDER	1		1					
11	2	119625-11880	SEAT, NOZZLE	3		3					
13	2	119625-11900	RETAINER, NOZZLE	3		3					
15	2	26216-060202	STUD, M6X 20	6		6					
16	2	27241-400000	PLUG, 40	2		2					
17	2	129100-11100	VALVE, INTAKE	3		3					
18	2	129100-11110	VALVE, EXHAUST	3		3					
18-1	2	129100-11111	VALVE, EXHAUST	3		3					N
(A=E/#43125) (C=E/#78449)											
19	2	129795-11120	SPRING, VALVE	6		6					
20	2	129795-11180	RETAINER, SPRING	6		6					
21	2	27310-080001	COTTER, 8	6		6					
22	2	121400-11340	SEAL, VALVE STEM	3		3					
23	2	124460-11340	SEAL, VALVE STEM	3		3					
24	2	129150-11370	CAP, VALVE	6		6					
25	2	119625-11870	PROTECTOR, NOZZLE	3		3					
26	2	120130-11860	GUIDE, VALVE	3		3					1
27	2	129150-11810	GUIDE, VALVE	3		3					1
28	1	129155-11241	SHAFT ASSY, ROCKER	1		1					
29	2	129155-11260	SUPPORT, ROCKER ARM	2		2					
30	2	129155-11270	SUPPORT, ROCKER ARM	2		2					
31	2	129150-11280	SPRING	3		3					
32	2	129150-11290	SHAFT, ROCKER ARM	1		1					
35	2	729402-11650	ARM ASSY, ROCKER	6		6					
36	3	129150-11230	SCREW, VALVE ADJUST	6		6					
38	3	129150-11750	NUT, M8	6		6					
39	2	26226-080182	STUD, M8X 18	3		3					
39-1	2	119802-11280	STUD	3		3					R
(A=E/#43125) (C=E/#66517)											
40	1	22351-060012	PIN, SPRING 6.0X12	2		2					
41	1	26106-080252	BOLT, M8X 25 PLATED	2		2					
42	1	26106-080502	BOLT, M8X 50 PLATED	6		6					
43	1	26366-060002	NUT, M6	6		6					
44	1	129100-11350	BONNET ASSY, HEAD	1		1					
44-1	1	129100-11351	BONNET ASSY, HEAD	1		1					N
(A=E/#43125) (C=E/#51224)											
44-2	1	729132-11521	BONNET ASSY, HEAD	1		1					R
(A=E/#43125) (C=E/#51224)											
46	2	129150-03020	COVER, BREATHER	1		1					
47	2	129150-03070	BAFFLE, BREATHER	1		1					
48	2	129150-03080	PLATE, BAFFLE	1		1					
51	2	129150-11310	GASKET, BONNET	1		1					
53	2	24341-000500	O-RING, 1AS50.0	1		1					
54	2	26106-080162	BOLT, M8X 16 PLATED	2		2					
55	1	124160-11360	KNOB	3		3					
56	1	24311-000120	O-RING, 1AP12.0	3		3					
57	1	124160-01751	COVER, FILLER	1		1					
58	1	24311-000320	O-RING, 1AP32.0	1		1					

Remarks

(1)REPAIR PART.

N:Old  $\xrightarrow{\text{Yes}}$  New, Q:Old  $\xrightarrow{\text{No}}$  New, R:Old  $\xrightarrow{\text{Yes}}$  New, S:Old  $\xrightarrow{\text{No}}$  New, W:Add, Z:Discontinued, F:Interchangeable by set, K:Q'ty Change

Fig.5. CYLINDER HEAD & BONNET

(A)=3TNE84-KAH  
(B)=3TNE84T-KAH  
(C)=3TNE84-EKAH

(D)=3TNE84T-EKAH  
(E)=  
(F)=

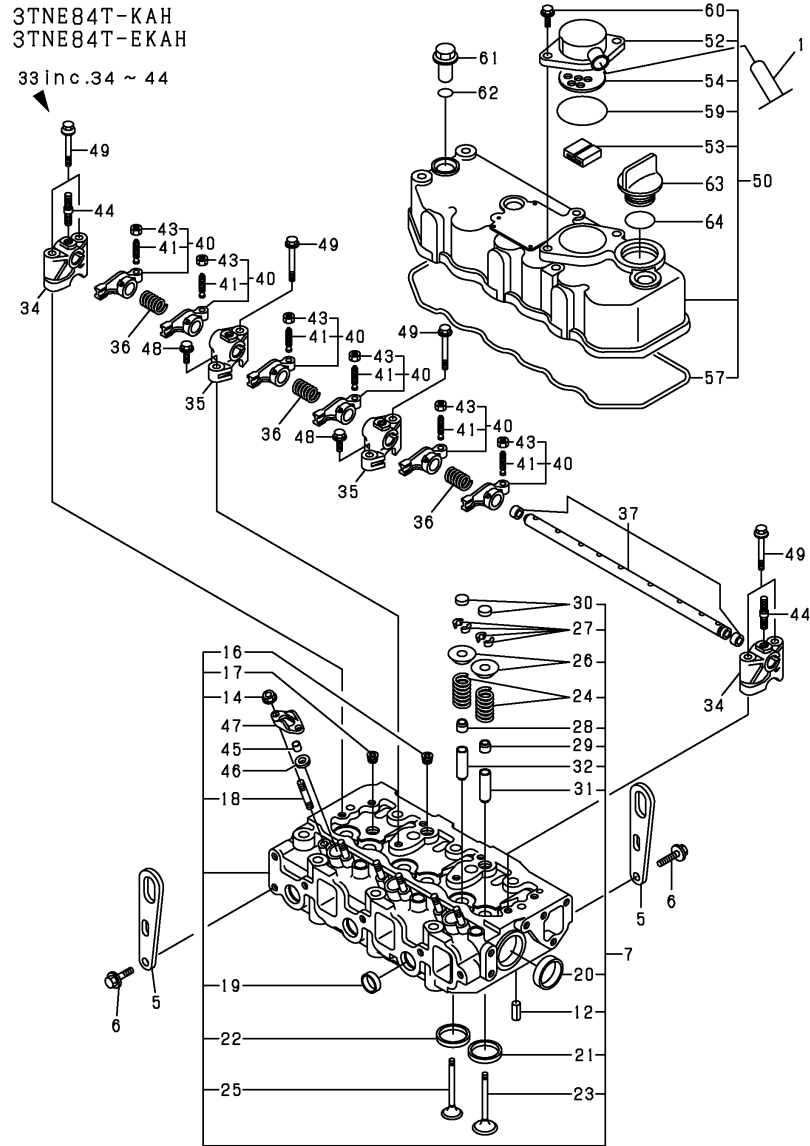

No.	Lev.	Parts No.	Description	Q'ty						I	R
				(A)	(B)	(C)	(D)	(E)	(F)		
1	1	129150-03090	HOSE, ID16X2T		1		1				
5	1	124736-07900	LIFTER		2		2				
6	1	26106-080142	BOLT, M8X 14 PLATED		4		4				
7	1	729202-11710	HEAD ASSY, CYLINDER		1		1				
12	2	22351-060012	PIN, SPRING 6.0X12		2		2				
14	2	26366-060002	NUT, M6		6		6				
16	2	23871-020000	PLUG, R02		2						
16-1	2	23876-020000 (B=E/#46340)	PLUG, R02		2		2				N
17	2	23871-030000	PLUG, R03		3						
17-1	2	23876-030000 (B=E/#46340)	PLUG, R03		3		3				N
18	2	26216-060202	STUD, M6X 20		6		6				
19	2	27241-220000	PLUG, 22		3		3				
20	2	27241-400000	PLUG, 40		2		2				
21	2	129470-11080	SEAT, INTAKE VALVE		3		3				
22	2	129470-11090	SEAT, EXHAUST VALVE		3		3				
23	2	129100-11100	VALVE, INTAKE		3		3				
24	2	129795-11120	SPRING, VALVE		6		6				
25	2	129100-11130	VALVE, EXHAUST		3		3				
26	2	129795-11180	RETAINER, SPRING		6		6				
27	2	27310-080001	COTTER, 8		6		6				
28	2	121400-11340	SEAL, VALVE STEM		3		3				
29	2	124460-11340	SEAL, VALVE STEM		3		3				
30	2	129150-11370	CAP, VALVE		6		6				
31	2	120130-11860	GUIDE, VALVE		3		3				1
32	2	129150-11810	GUIDE, VALVE		3		3				1
33	1	129155-11241	SHAFT ASSY, ROCKER		1		1				
34	2	129155-11260	SUPPORT, ROCKER ARM		2		2				
35	2	129155-11270	SUPPORT, ROCKER ARM		2		2				
36	2	129150-11280	SPRING		3		3				
37	2	129150-11290	SHAFT, ROCKER ARM		1		1				
40	2	729402-11650	ARM ASSY, ROCKER		6		6				
41	3	129150-11230	SCREW, VALVE ADJUST		6		6				
43	3	129150-11750	NUT, M8		6		6				
44	2	26226-080182	STUD, M8X 18		3		3				
44-1	2	119802-11280 (B=E/#46340)	STUD		3		3				R
45	1	119625-11870	PROTECTOR, NOZZLE		3		3				
46	1	119625-11880	SEAT, NOZZLE		3		3				
47	1	119625-11900	RETAINER, NOZZLE		3		3				
48	1	26106-080252	BOLT, M8X 25 PLATED		2		2				
49	1	26106-080502	BOLT, M8X 50 PLATED		6		6				
50	1	129100-11350	BONNET ASSY, HEAD		1		1				
50-1	1	129100-11351 (B=E/#46340)	BONNET ASSY, HEAD		1		1				N
50-2	1	729132-11521 (B=E/#46340)	BONNET ASSY, HEAD		1		1				R
52	2	129150-03020	COVER, BREATHER		1		1				
53	2	129150-03070	BAFFLE, BREATHER		1		1				
54	2	129150-03080	PLATE, BAFFLE		1		1				

Remarks

(1)REPAIR PART.



Fig.5. CYLINDER HEAD & BONNET

(A)=3TNE84-KAH  
(B)=3TNE84T-KAH  
(C)=3TNE84-EKAH

(D)=3TNE84T-EKAH  
(E)=  
(F)=

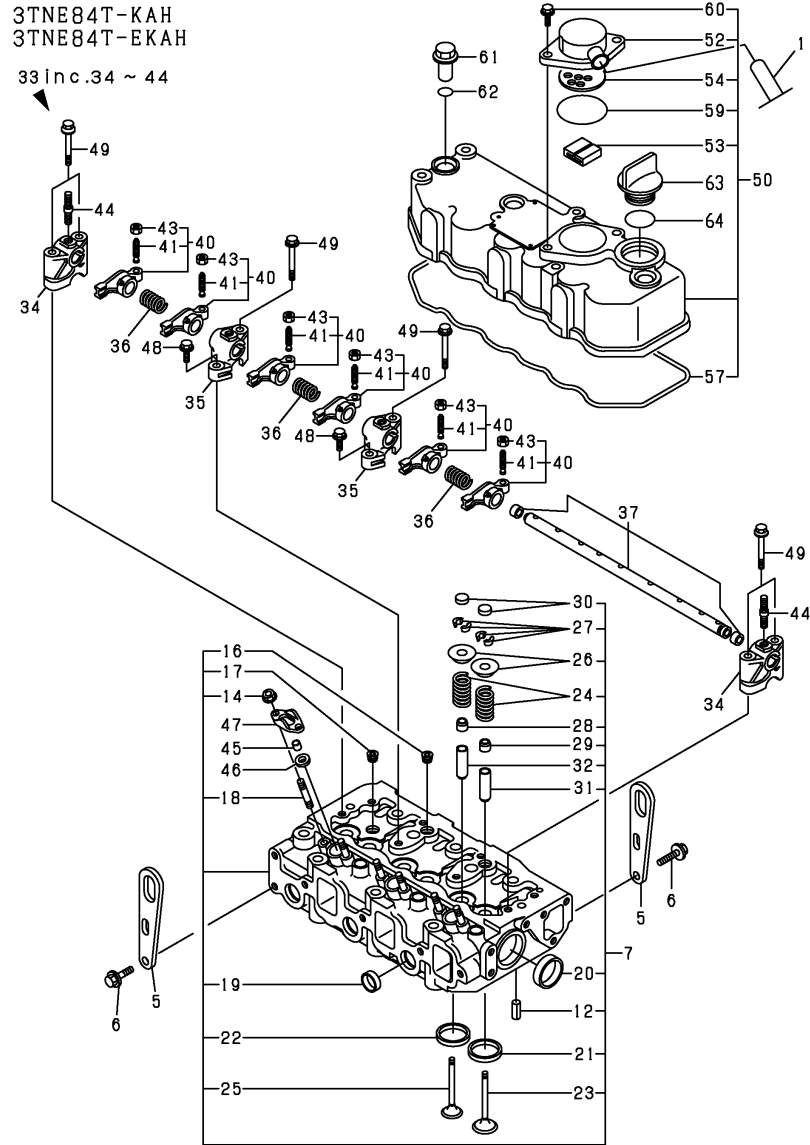

No.	Lev.	Parts No.	Description	Q'ty						I	R
				(A)	(B)	(C)	(D)	(E)	(F)		
57	2	129150-11310	GASKET, BONNET		1		1				
59	2	24341-000500	O-RING, 1AS50.0		1		1				
60	2	26106-080162	BOLT, M8X 16 PLATED		2		2				
61	1	124160-11360	KNOB		3		3				
62	1	24311-000120	O-RING, 1AP12.0		3		3				
63	1	124160-01751	COVER, FILLER		1		1				
64	1	24311-000320	O-RING, 1AP32.0		1		1				

Remarks  
(1)REPAIR PART.

Fig.6. SUCTION MANIFOLD

(A)=3TNE84-KAH  
(B)=3TNE84T-KAH  
(C)=3TNE84-EKAH

(D)=3TNE84T-EKAH  
(E)=  
(F)=

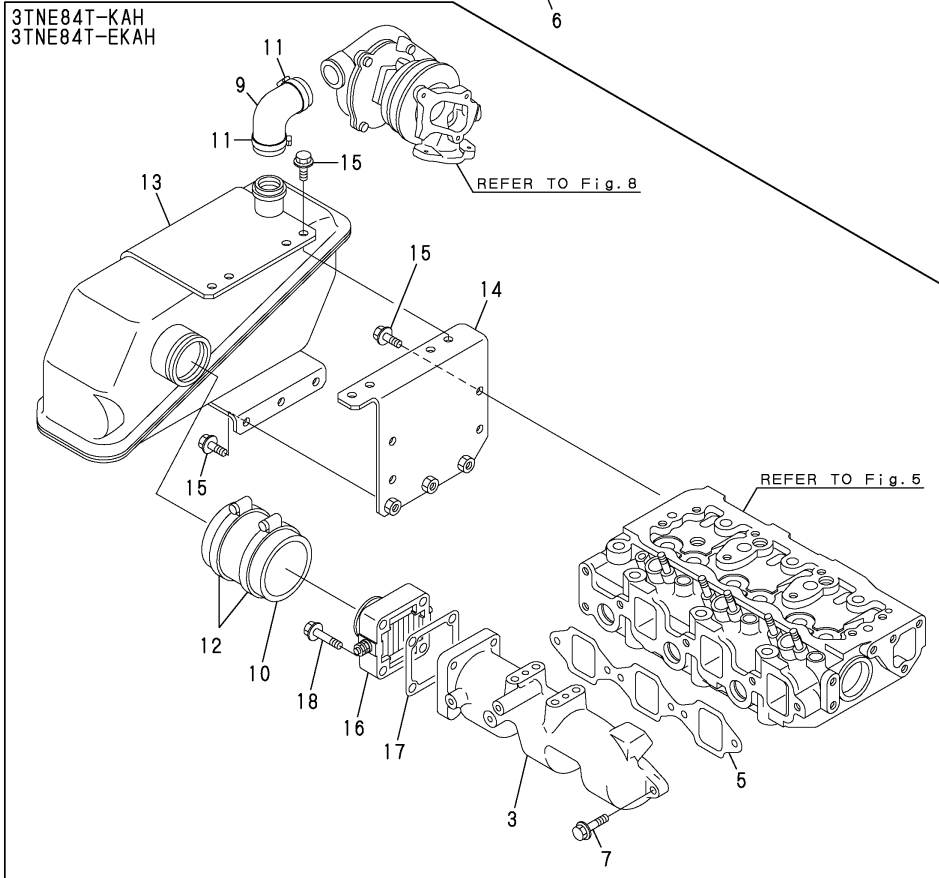
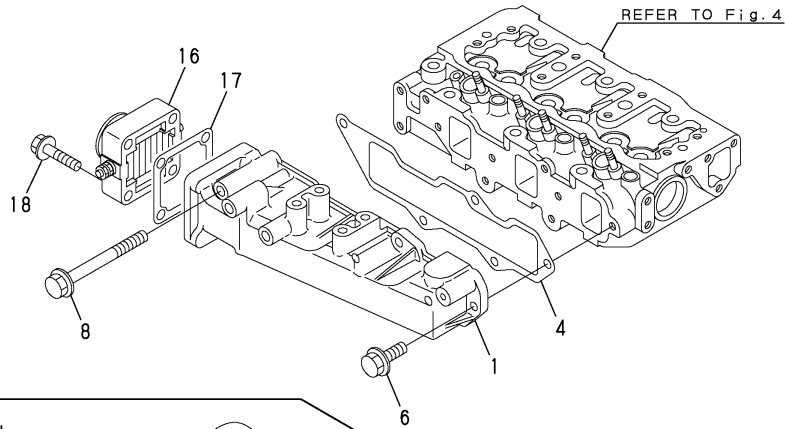

No.	Lev.	Parts No.	Description	Q'ty						I	R
				(A)	(B)	(C)	(D)	(E)	(F)		
1	1	129001-12100	MANIFOLD, AIR INTAKE	1		1					
3	1	129122-12100	MANIFOLD, AIR INTAKE		1		1				
4	1	129001-12110	GASKET, MANIFOLD	1		1					
5	1	129150-12111	GASKET, MANIFOLD		1		1				
6	1	26106-080202	BOLT, M8X 20 PLATED	4		4					
7	1	26106-080252	BOLT, M8X 25 PLATED		4		4				
8	1	26106-080802	BOLT, M8X 80 PLATED	1		1					
9	1	129139-12050	HOSE, WATER		1		1				
10	1	129122-12060	HOSE		1		1				
11	1	23000-041000	CLAMP, 41		2		2				
12	1	23000-060000	CLAMP, 60		2		2				
13	1	129139-12200	TANK, SURGE		1		1				
14	1	129122-12211	BRACKET		1		1				
15	1	26106-080162	BOLT, M8X 16 PLATED		11		11				
16	1	129120-77501	HEATER	1	1	1	1				
17	1	129150-77511	GASKET	1	1	1	1				
18	1	26106-080352	BOLT, M8X 35 PLATED	4	4	4	4				

Fig.7. EXHAUST MANIFOLD

(A)=3TNE84-KAH  
(B)=3TNE84T-KAH  
(C)=3TNE84-EKAH

(D)=3TNE84T-EKAH  
(E)=  
(F)=

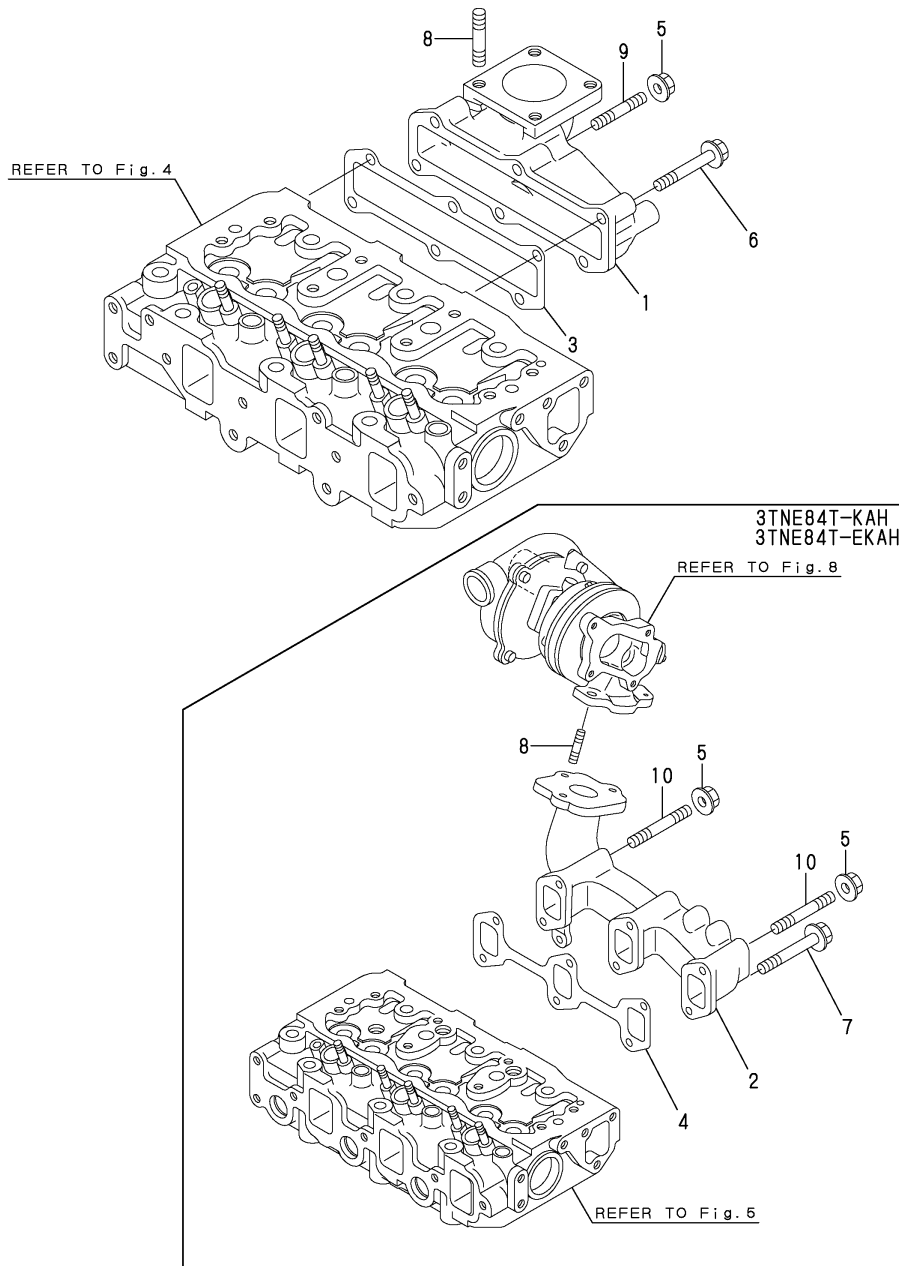

No.	Lev.	Parts No.	Description	Q'ty						I	R
				(A)	(B)	(C)	(D)	(E)	(F)		
1	1	129001-13100	MANIFOLD, EXHAUST	1		1					
2	1	129139-13100	MANIFOLD, EXHAUST		1		1				
3	1	129001-13110	GASKET	1		1					
4	1	129150-13110	GASKET		1		1				
5	1	26366-080002	NUT, M8	2	2	2	2				
5-1	1	26306-080002	NUT, M8	2	2						R
(A=E/#43125) (C=E/#63670)											
6	1	26106-080402	BOLT, M8X 40 PLATED	4		4					
6-1	1	119802-13600	BOLT, M8X40	4		4					S
(A=E/#43125) (C=E/#72498)											
7	1	26106-080802	BOLT, M8X 80 PLATED		4		4				
7-1	1	123900-13630	BOLT, M8X80		4		4				N
(B=E/#46340) (D=E/#63398)											
7-2	1	123900-13630	BOLT, M8X80		6		6				K
(B=E/#46340) (D=E/#75515)											
8	1	119131-18320	STUD, M8X22	4	3	4	3				
9	1	26216-080402	STUD, M8X 40	2		2					
9-1	1	119802-13710	STUD, M8X40	2		2					N
(A=E/#43125) (C=E/#72498)											
10	1	26216-080802	STUD, M8X 80		2		2				
10-1	1	123900-13630	BOLT, M8X80		2		2				N
(B=E/#46340) (D=E/#63398)											
10-2	1	123900-13630	BOLT, M8X80		2		2				Z
(B=E/#46340) (D=E/#75515)											

Fig.8. TURBOCHARGER

(A)=3TNE84-KAH  
(B)=3TNE84T-KAH  
(C)=3TNE84-EKAH

(D)=3TNE84T-EKAH  
(E)=  
(F)=

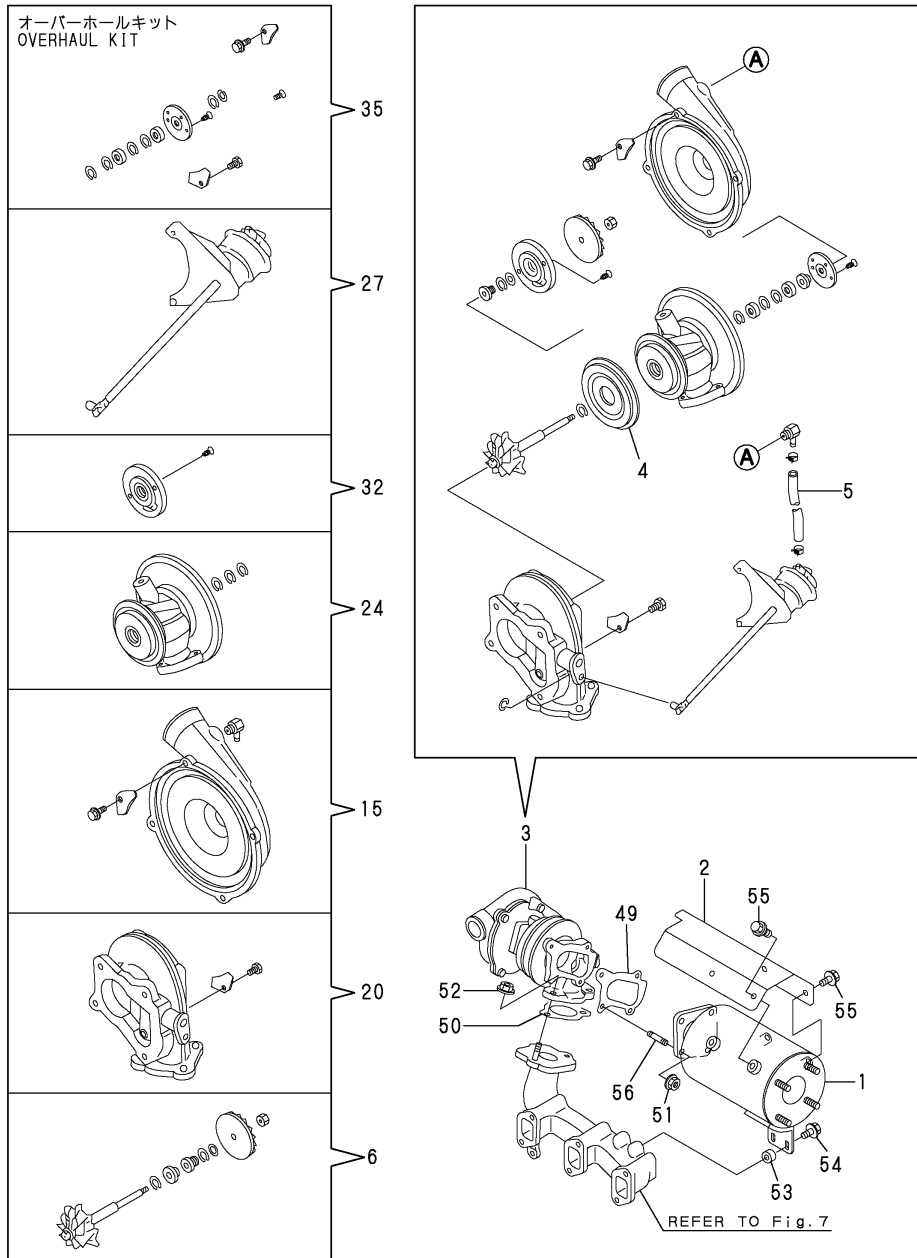

No.	Lev.	Parts No.	Description	Q'ty						I	R
				(A)	(B)	(C)	(D)	(E)	(F)		
1	1	129012-13300	RESONATOR		1		1				
1-1A	1	129012-13301	RESONATOR				1				R
				(D=E/#59540)							
2	1	129012-13410	COVER, RESONATOR		1		1				
2-1A	1	129012-13411	COVER, RESONATOR				1				R
				(D=E/#59540)							
3	1	129137-18010	TURBINE, RHB31W/G			1		1			
4	2	129403-18720	PROTECTOR, HEAT		1		1				
5	2	129403-18750	HOSE		1		1				
6	2	129403-18770	ROTOR ASSY, TURBO		1		1				
15	2	129403-18780	HOUSING ASSY, BLOWER		1		1				
20	2	XNB139825	HOUSING ASSY, TURBO		1		1				
24	2	129403-18800	HOUSING ASSY		1		1				
27	2	XNB139826	CONTROL ASSY		1		1				
32	2	XNB139815	SEAL PLATE ASSY		1		1				
35	2	XNB139827	OVERHAUL KIT		1		1				
49	1	129403-18091	GASKET		1		1				
50	1	129477-18101	GASKET		1		1				
50-1	1	129535-18100	GASKET						1		N
				(D=E/#61031)							
51	1	194990-22050	NUT, M8			4		4			
51-1	1	26306-080002	NUT, M8						4		N
				(D=E/XXX)							
52	1	194990-22050	NUT, M8			3		3			
52-1	1	26306-080002	NUT, M8						3		N
				(D=E/XXX)							
53	1	106500-44810	SPACER		2		2				
54	1	26014-080252	BOLT, M8X 25		2		2				
55	1	26106-080102	BOLT, M8X 10 PLATED		4		4				
56	1	119131-18320	STUD, M8X22		4		4				
56-1	1	129418-18320	STUD, M8X20		4		4				R
				(B=E/#38284)							

Fig.9. CAMSHAFT & DRIVING GEAR

(A)=3TNE84-KAH  
(B)=3TNE84T-KAH  
(C)=3TNE84-EKAH

(D)=3TNE84T-EKAH  
(E)=  
(F)=

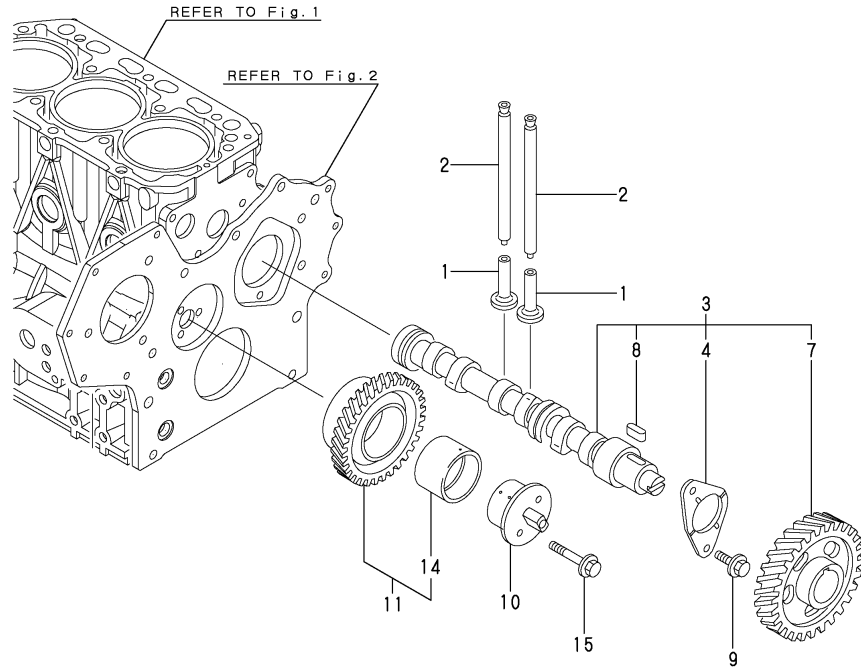

No.	Lev.	Parts No.	Description	Q'ty						I	R
				(A)	(B)	(C)	(D)	(E)	(F)		
1	1	129150-14200	TAPPET	6	6	6	6				
2	1	129150-14400	ROD, PUSH L=178	6	6	6	6				
3	1	129129-14580	CAMSHAFT ASSY	1	1	1	1				
4	2	129150-02450	BEARING, THRUST	1	1	1	1				
7	2	129150-14101	GEAR, CAMSHAFT	1	1	1	1				
8	2	22512-070140	KEY, 7X 14	1	1	1	1				
9	1	26106-080142	BOLT, M8X 14 PLATED	2	2	2	2				
10	1	129100-25061	SHAFT, IDLE	1	1	1	1				
11	1	129150-25101	GEAR ASSY, IDLE	1	1	1	1				
14	2	129150-25920	BUSH, IDLE GEAR	1	1	1	1				1
15	1	26106-080452	BOLT, M8X 45 PLATED	2	2	2	2				

Remarks

(1)REPAIR PART.

(A)=3TNE84-KAH  
 (B)=3TNE84T-KAH  
 (C)=3TNE84-EKAH

(D)=3TNE84T-EKAH  
 (E)=  
 (F)=

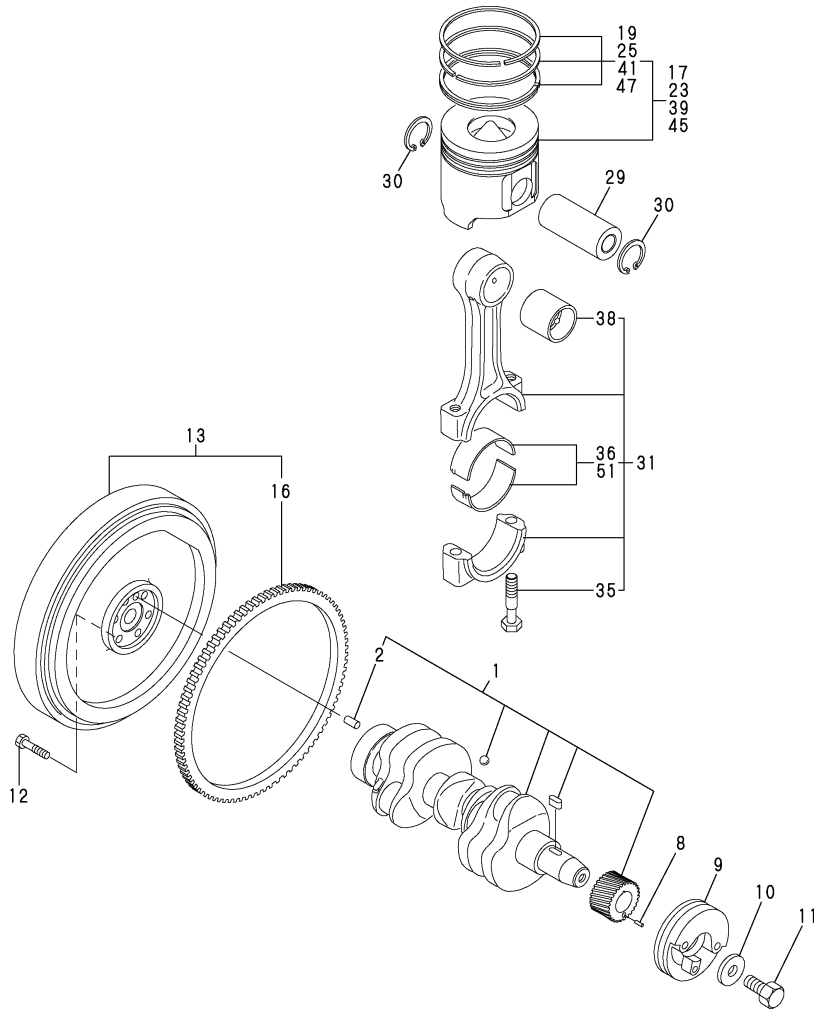

No.	Lev.	Parts No.	Description	Qty						I	R
				(A)	(B)	(C)	(D)	(E)	(F)		
1	1	129001-21000	CRANKSHAFT ASSY	1	1	1	1				
1-1	1	129001-21100	CRANKSHAFT ASSY	1	1	1	1				S
		(A=E/#43125) (B=E/#46340) (C=E/#56331) (D=E/#56114)									
2	2	129100-01580	PIN, M8X16	1	1	1	1				
8	1	22351-040010	PIN, SPRING 4.0X10	1	1	1	1				
9	1	171340-21650	V-PULLEY	1	1	1	1				
10	1	129795-21661	WASHER	1	1	1	1				
11	1	121850-21680	BOLT	1	1	1	1				
12	1	124160-21501	BOLT, FLYWHEEL	6	6	6	6				
13	1	129131-21591	FLYWHEEL ASSY	1	1	1	1				
16	2	124550-21600	GEAR, RING	1	1	1	1				
17	1	129002-22081	PISTON ASSY	3		3					
19	2	129002-22500	RING SET, PISTON	3		3					
23	1	129002-22090	PISTON ASSY		3		3				
25	2	129002-22960	RING SET, 0.25 OS		3		3				
29	1	129202-22300	PIN, PISTON D26 L70	3	3	3	3				
30	1	22252-000260	RING, 26	6	6	6	6				
31	1	729402-23100	ROD ASSY, CONNECTING	3	3	3	3				
35	2	121550-23200	BOLT, CONNECTING ROD	6	6	6	6				
36	2	129150-23600	BEARING, CRANK PIN	3	3	3	3				
38	2	129100-23910	BEARING, PISTON PIN	3	3	3	3				1
39	1	129002-22900	PISTON ASSY, 0.25 OS	3		3					2
41	2	129002-22950	RING SET, 0.25 OS	3		3					2
45	1	129002-22910	PISTON ASSY, 0.25 OS		3		3				2
47	2	129002-22960	RING SET, 0.25 OS		3		3				2
51	1	129150-23610	BEARING, 0.25 US	3	3	3	3				3

Remarks  
 (1)REPAIR PART.  
 (2)OVER SIZED(O.S.=0.25)PART.  
 (3)UNDER SIZED(U.S.=0.25)PART.

Fig.11. LUB.OIL SYSTEM

(A)=3TNE84-KAH  
(B)=3TNE84T-KAH  
(C)=3TNE84-EKAH

(D)=3TNE84T-EKAH  
(E)=  
(F)=

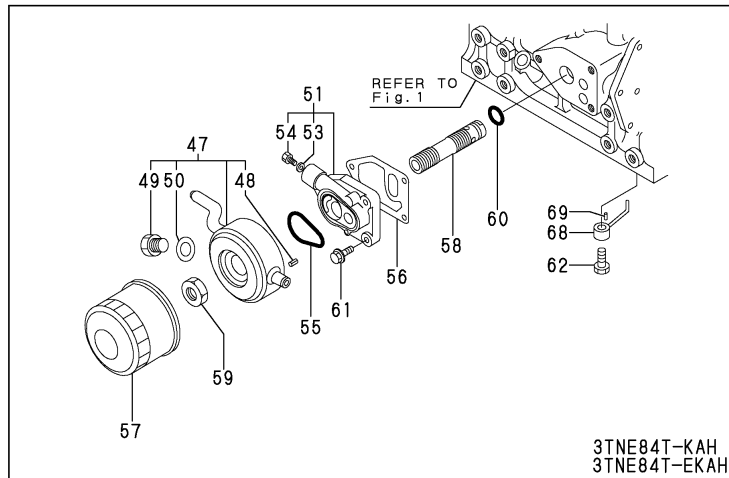
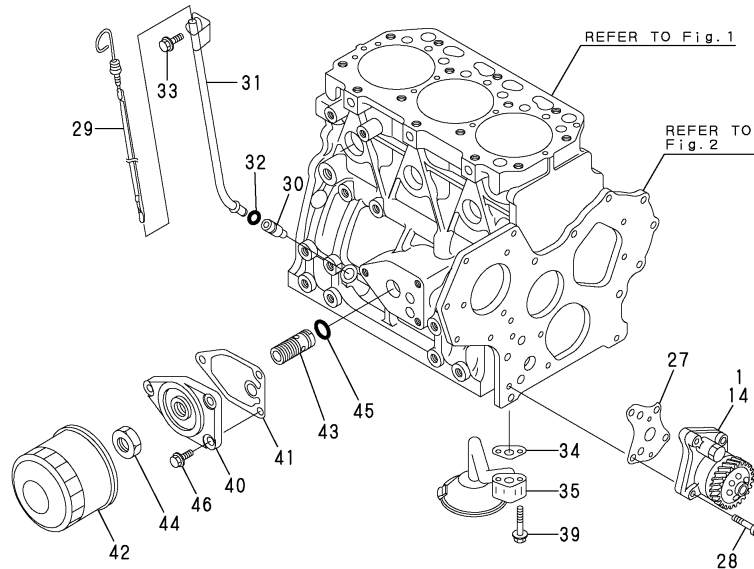

No.	Lev.	Parts No.	Description	Qty						I	R
				(A)	(B)	(C)	(D)	(E)	(F)		
1	1	129001-32001	PUMP ASSY, OIL	1		1					
14	1	129418-32000	PUMP ASSY, OIL		1			1			
27	1	129150-32020	GASKET, PUMP	1	1	1	1				
28	1	26450-060252	BOLT, M6X 25	4	4	4	4				
29	1	129135-34800	DIPSTICK, OIL	1	1	1	1				
30	1	119260-34810	GUIDE, DIPSTICK	1	1	1	1				
31	1	129136-34820	GUIDE, DIPSTICK	1	1	1	1				
32	1	24311-240100	O-RING, 1AP10A	2	2	2	2				
33	1	26106-080252	BOLT, M8X 25 PLATED	1	1	1	1				
34	1	129150-35041	GASKET	1	1	1	1				
34-1	1	129150-35042	GASKET	1	1	1	1				N
(A=E/#43125) (B=E/#46340) (C=E/#78449) (D=E/#78826)											
35	1	129135-35090	PIPE ASSY, OIL INLET	1	1	1	1				
39	1	26106-080352	BOLT, M8X 35 PLATED	2	2	2	2				
40	1	129150-35101	BRACKET, STRAINER	1		1					
41	1	129150-35111	GASKET	1		1					
42	1	129150-35170	FILTER, LO	1		1					1
43	1	129001-35300	BOLT, FILTER	1		1					
44	1	129150-35350	NUT	1		1					
45	1	24311-000160	O-RING, 1AP16.0	1		1					
46	1	26106-080202	BOLT, M8X 20 PLATED	3		3					
47	1	129012-33000	COOLER ASSY, OIL		1		1				
48	2	129120-33040	PIN		2		2				
49	2	129120-33051	PLUG, DRAIN		1		1				
50	2	129120-33060	GASKET		1		1				
51	1	129120-35001	BRACKET ASSY		1		1				
53	2	23414-100000	GASKET, 10X1.0		1		1				
54	2	23881-100002	PLUG, 10		1		1				
55	1	129120-35110	GASKET		1		1				
56	1	129120-35121	GASKET		1		1				
57	1	129150-35170	FILTER, LO		1		1				1
58	1	129407-35300	BOLT, FILTER		1		1				
59	1	129150-35350	NUT		1		1				
60	1	24311-000160	O-RING, 1AP16.0		1		1				
61	1	26106-080252	BOLT, M8X 25 PLATED		3		3				
62	1	129792-39410	VALVE ASSY, CHECK		3		3				
68	1	129553-39650	NOZZLE		3		3				
69	1	22351-030010	PIN, SPRING 3.0X10		3		3				

Remarks  
(1) REPAIR PART.

Fig.12. LUB.OIL PIPE

(A)=3TNE84-KAH  
(B)=3TNE84T-KAH  
(C)=3TNE84-EKAH

(D)=3TNE84T-EKAH  
(E)=  
(F)=

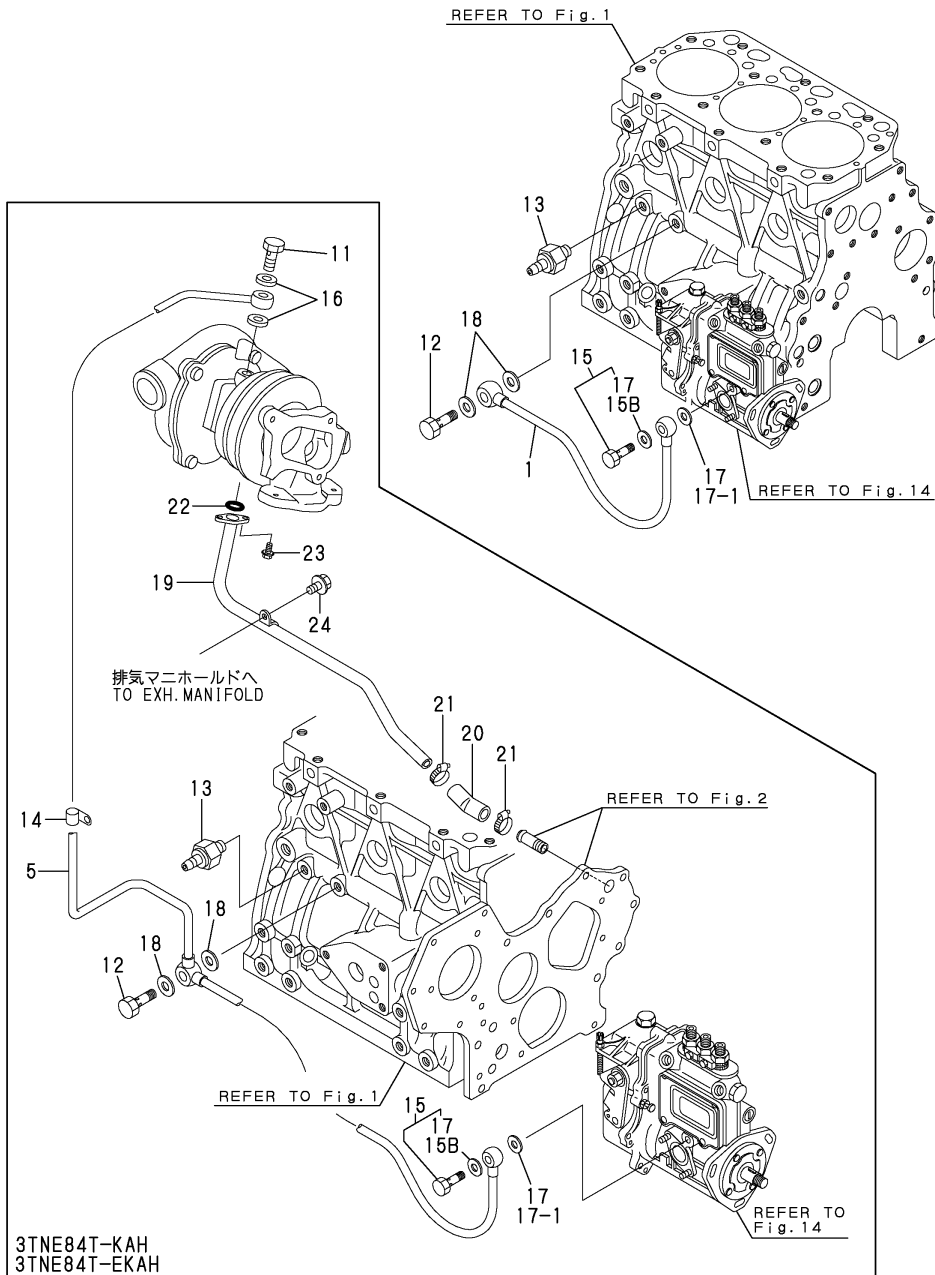

No.	Lev.	Parts No.	Description	Qty						I	R
				(A)	(B)	(C)	(D)	(E)	(F)		
1	1	129150-39450	PIPE ASSY, OIL	1		1					
5	1	129139-39030	PIPE ASSY, OIL		1		1				
11	1	105010-39140	BOLT, PIPE JOINT		1		1				
12	1	124160-39140	BOLT, PIPE JOINT M10	1	1	1	1				
13	1	124160-39450	SWITCH, 0.5KG	1	1	1	1				
13-1	1	114250-39450	SWITCH, 0.5KG	1	1	1	1				N
		(A=#43125) (B=#46340) (C=#51799) (D=#51658)									
14	1	124223-39900	RETAINER		1		1				
15	1	124550-59830	BOLT ASSY, JOINT M8	1	1	1	1				W
		(A=#43125) (B=#46278)									
15B	2	22190-080002	WASHER, SEAL 6	1	1	1	1				W
		(A=#43125) (B=#46278)									
15B-1	2	22190-080003	WASHER, SEAL 8	1	1	1	1				N
		(A=#43125) (B=#46340) (C=#49602) (D=#49851)									
15B-2	2	22190-080002	WASHER, SEAL 6	1	1	1	1				N
		(A=#43125) (B=#46340) (C=#51224) (D=#50846)									
16	1	22190-080002	WASHER, SEAL 6		2						
16-1	1	23414-080000	GASKET, 8X1.0		2		2				N
		(B=EXXX)									
17	1	23414-080000	GASKET, 8X1.0	2	2						
17-1	1	22190-080002	WASHER, SEAL 6	1	1	1	1				S
		(A=EXXX) (B=EXXX)									
17-2	1	22190-080003	WASHER, SEAL 8	1	1	1	1				N
		(A=#43125) (B=#46340) (C=#49602) (D=#49851)									
17-3	1	22190-080002	WASHER, SEAL 6	1	1	1	1				N
		(A=#43125) (B=#46340) (C=#51224) (D=#50846)									
18	1	23414-100000	GASKET, 10X1.0	2	2	2	2				
18-1	1	22190-100002	WASHER, SEAL 10	2	2	2	2				N
		(A=#43125) (B=#46340) (C=#51224) (D=#50846)									
19	1	129139-39601	PIPE, OIL		1		1				
20	1	129403-39610	JOINT, RUBBER		1		1				
21	1	23000-022000	CLAMP, 22		2		2				
22	1	24314-000160	O-RING, 4CP16.0		1		1				
22-1	1	24316-000160	O-RING, 4DP16.0		1		1				N
		(B=#46340) (D=#78826)									
23	1	26106-060162	BOLT, M6X 16 PLATED		2		2				
24	1	26106-080122	BOLT, M8X 12 PLATED		1		1				



(A)=3TNE84-KAH  
 (B)=3TNE84T-KAH  
 (C)=3TNE84-EKAH

(D)=3TNE84T-EKAH  
 (E)=  
 (F)=

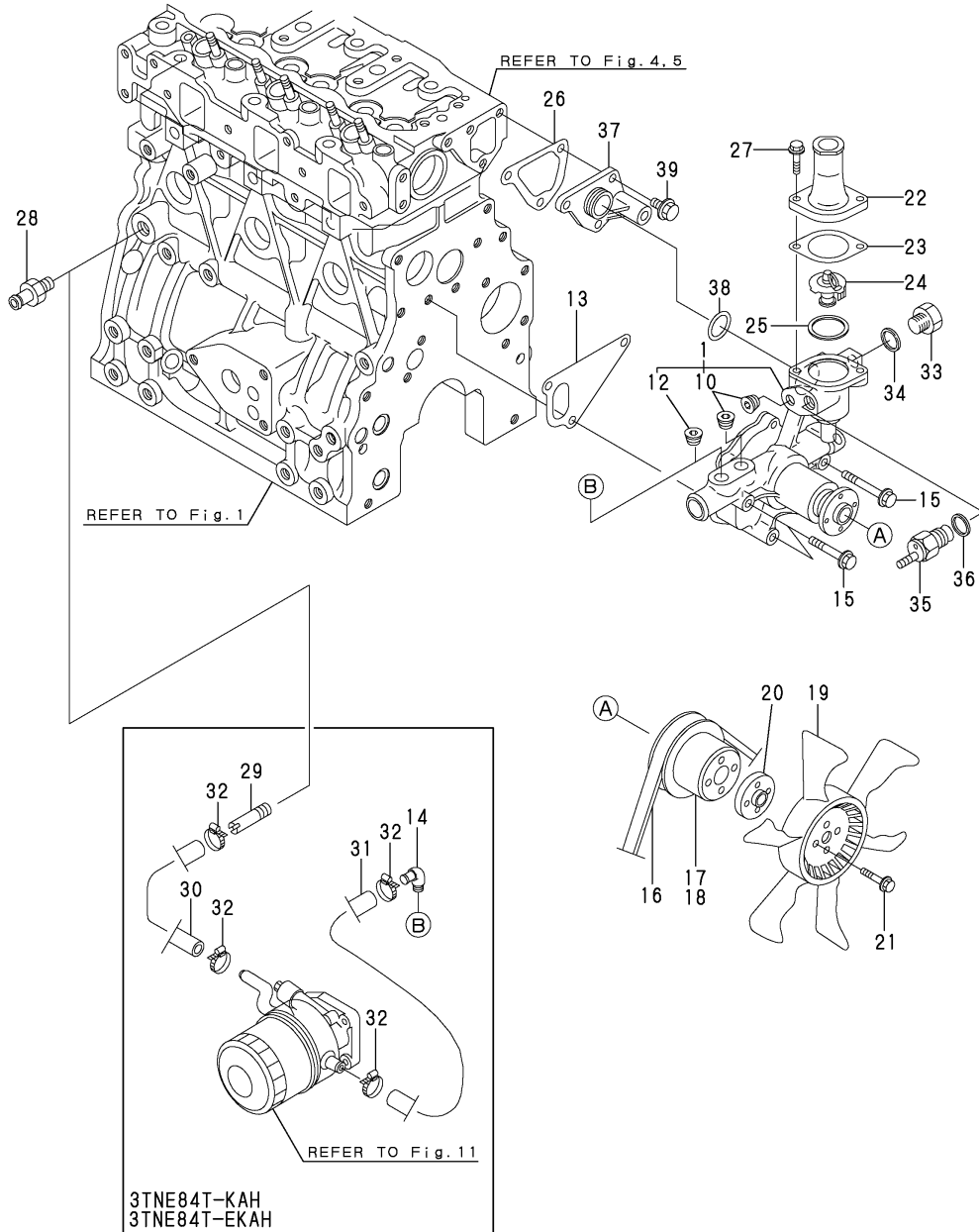

No.	Lev.	Parts No.	Description	Q'ty						I	R
				(A)	(B)	(C)	(D)	(E)	(F)		
1	1	129001-42002	PUMP ASSY, WATER	1	1						
1-1	1	129001-42003	PUMP ASSY, WATER	1	1	1	1				N
		(A=E/#43125) (B=E/#46340)									
10	2	23871-030000	PLUG, R03	2	2						
10-1	2	23876-030000	PLUG, R03	2	2	2	2				N
		(A=E/#43125) (B=E/#46340)									
12	2	23871-020000	PLUG, R02	1	1						
12-1	2	23876-020000	PLUG, R02	1	1	1	1				N
		(A=E/#43125) (B=E/#46340)									
13	1	129100-42020	GASKET, WATER PUMP	1	1						
13-1	1	129486-42021	GASKET, WATER PUMP	1	1	1	1				N
		(A=E/#43125) (B=E/#46340)									
14	1	129103-49301	ELBOW, PT1/4		1		1				
15	1	26106-080602	BOLT, M8X 60 PLATED	3	3	3	3				
16	1	25132-003900	V-BELT, A39	1	1	1	1				
16-1	1	25132-003800	V-BELT, A38			1	1				N
		(C=E/#51224) (D=E/#50846)									
17	1	129120-42350	V-PULLEY, 130	1	1						
17-1	1	129403-42380	V-PULLEY, D=110			1					N
		(C=E/#51224)									
18	1	129550-42350	V-PULLEY, D=120		1		1				
18-1	1	129403-42380	V-PULLEY, D=110				1				N
		(D=E/#50846)									
19	1	171440-44740	FAN, COOLING D350XQF	1	1	1	1				
20	1	124574-44761	SPACER, FAN	1	1	1	1				
21	1	26014-060252	BOLT, M6X 25	4	4	4	4				
22	1	129350-49560	COVER, THERMOSTAT	1	1	1	1				
23	1	129795-49551	GASKET	1	1	1	1				
24	1	129574-49800	THERMOSTAT, 82	1	1	1	1				
24-1	1	129457-49800	THERMOSTAT, 82	1	1	1	1				N
		(A=E/#43125) (B=E/#46340) (C=E/#63670) (D=E/#63398)									
24-2	1	129457-49801	THERMOSTAT, 82	1	1	1	1				N
		(A=E/#43125) (B=E/#46340) (C=E/#73483) (D=E/#73668)									
25	1	129150-49811	GASKET, THERMOSTAT	1	1	1	1				
26	1	129100-49840	GASKET	1	1	1	1				
26-1	1	124395-49840	GASKET	1	1	1	1				N
		(A=E/#43125) (B=E/#46340) (C=E/#67397) (D=E/#67935)									
27	1	26106-080202	BOLT, M8X 20 PLATED	2	2	2	2				
28	1	121550-49111	JOINT, PT1/4	1	1	1					
		(B=E/#46340) (D=E/#66324)									
29	1	129122-44480	JOINT		1		1				
30	1	129012-49030	HOSE, WATER		1		1				
31	1	129403-49060	PIPE ASSY, WATER		1		1				W
		(B=E/#46340) (D=E/#66324)									
31A	2	129403-49050	PIPE, WATER		1		1				
31B	2	129956-49230	TUBE, CORRUGATED		1		1				W
		(B=E/#46340) (D=E/#66324)									
32	1	23000-022000	CLAMP, 22		4		4				
33	1	121450-42450	PLUG, M16	1	1	1	1				
34	1	124465-44950	GASKET, 16	1	1	1	1				
35	1	124250-49351	SENSOR	1	1	1	1				
36	1	129150-49360	GASKET	1	1	1	1				

Fig.13. COOLING WATER SYSTEM

(A)=3TNE84-KAH  
(B)=3TNE84T-KAH  
(C)=3TNE84-EKAH

(D)=3TNE84T-EKAH  
(E)=  
(F)=

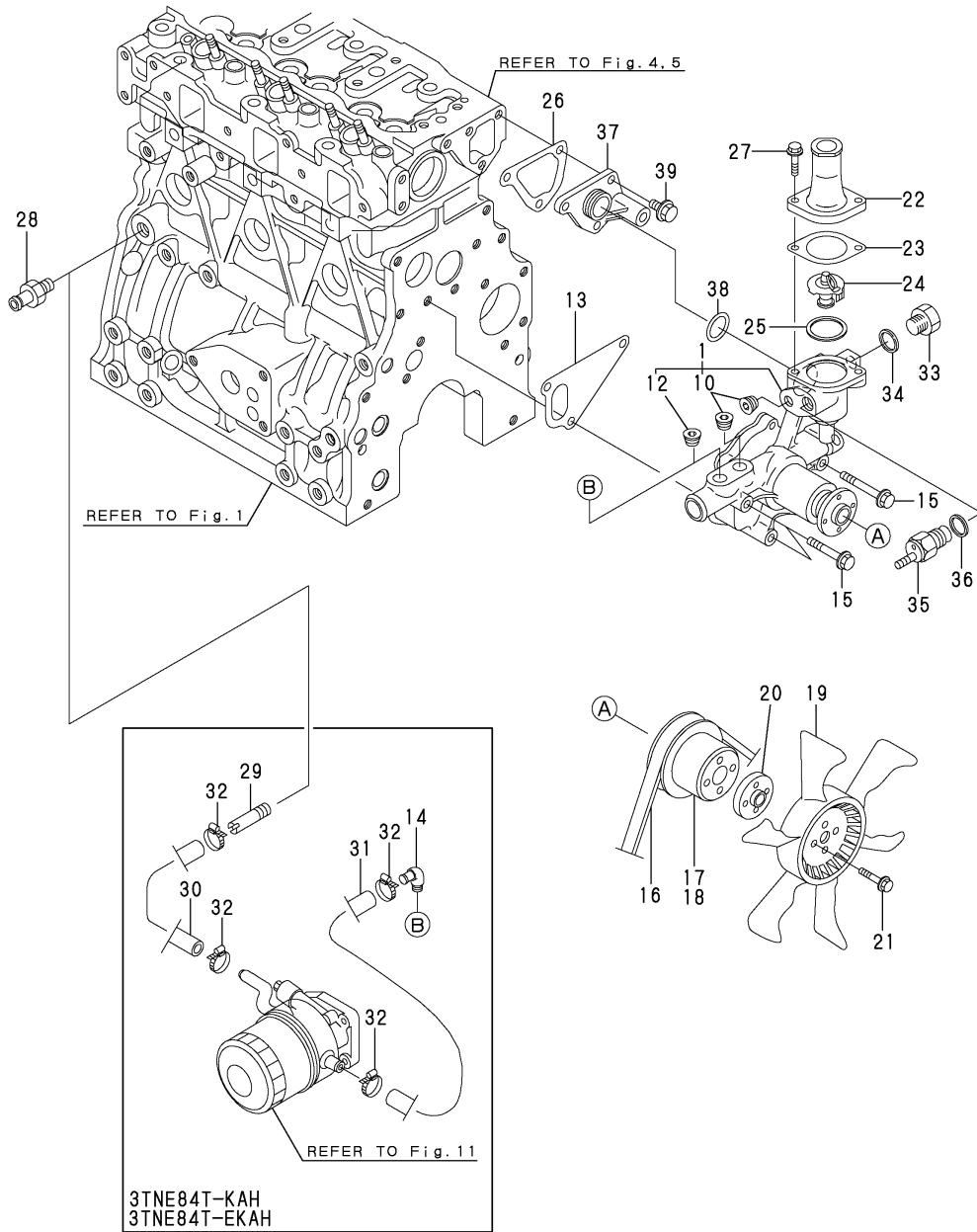

No.	Lev.	Parts No.	Description	Q'ty						I	R
				(A)	(B)	(C)	(D)	(E)	(F)		
37	1	129001-42040	JOINT	1	1	1	1				
38	1	24321-000300	O-RING, 1AG30.0	1	1						
38-1	1	129486-42140	O-RING, G30	1	1	1	1				N
		(A=E/#43125) (B=E/#46340)									
39	1	26106-080162	BOLT, M8X 16 PLATED	3	3	3	3				

Fig.14. FUEL INJECTION PUMP

(A)=3TNE84-KAH  
(B)=3TNE84T-KAH  
(C)=3TNE84-EKAH

(D)=3TNE84T-EKAH  
(E)=  
(F)=

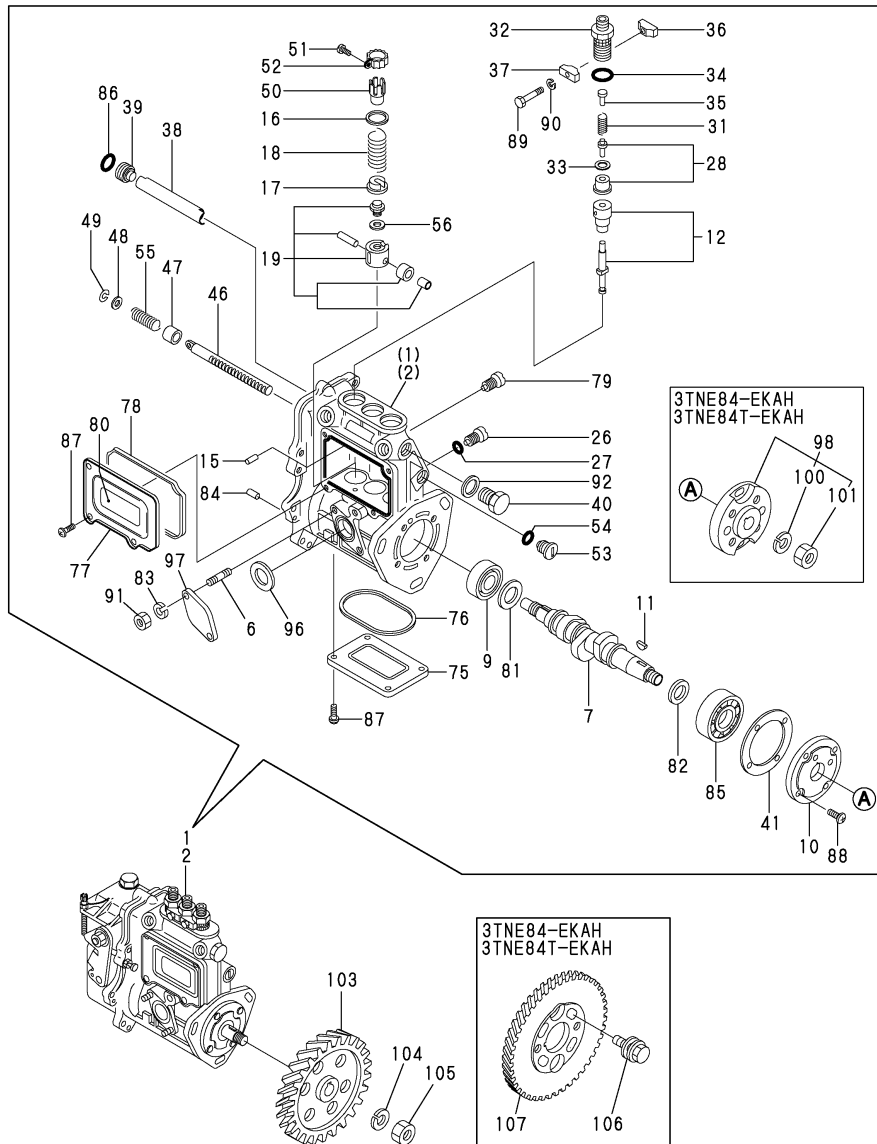

No.	Lev.	Parts No.	Description	Q'ty						I	R
				(A)	(B)	(C)	(D)	(E)	(F)		
1	1	729211-51360	PUMP ASSY, INJECTION	1							1
1A	1	729211-51460	PUMP ASSY, INJECTION			1					1
2	1	729012-51370	PUMP ASSY, INJECTION		1						1
2A	1	729012-51450	PUMP ASSY, INJECTION				1				1
6	2	129155-51020	STUD	2	2	2	2				
7	2	119810-51040	CAMSHAFT	1	1	1	1				
9	2	129155-51050	BEARING, 17BM001D	1	1	1	1				
9-1	2	129155-51051	BEARING	1	1	1	1				R
				(A=E/#43125)	(B=E/#46340)	(C=E/#71277)	(D=E/#71149)				
10	2	129155-51060	SUPPORT, CAMSHAFT	1	1						
10A	2	129208-51060	SUPPORT			1	1				
11	2	122710-51090	KEY	1	1	1	1				
12	2	129506-51100	PLUNGER ASSY	3	3	3	3				
15	2	129155-51140	PIN	3	3	3	3				
16	2	174307-51170	RETAINER, SPRING A	3	3	3	3				
17	2	129155-51180	RETAINER, SPRING	3	3	3	3				
18	2	124950-51190	SPRING, PLUNGER	3	3	3	3				
19	2	129155-51200	TAPPET ASSY	3	3	3	3				
26	2	129155-51270	STOPPER, TAPPET	3	3	3	3				
27	2	129155-51280	O-RING, S6	3	3	3	3				
28	2	129505-51300	VALVE ASSY, DELIVERY	3	3	3	3				
31	2	129155-51320	SPRING, DELIVERY	3	3	3	3				
32	2	129155-51340	RETAINER	3	3	3	3				
33	2	124550-51350	GASKET, DELIVERY	3	3	3	3				
34	2	124550-51370	O-RING	3	3	3	3				
35	2	129155-51370	STOPPER, VALVE	3	3	3	3				
36	2	129155-51380	STOPPER	2	2	2	2				
37	2	129155-51390	STOPPER	2	2	2	2				
38	2	129155-51400	DEFLECTOR	1	1	1	1				
39	2	129155-51410	BOLT	1	1	1	1				
40	2	129155-51420	PLUG, M16	1	1	1	1				
41	2	129155-51450	SHIM SET, ADJUSTING	1	1	1	1				
46	2	129155-51500	RACK, CONTROL	1	1	1	1				
46-1	2	119717-51500	RACK, CONTROL	1	1	1	1				R
				(A=E/#43125)	(B=E/#46340)	(C=E/#78449)	(D=E/#79394)				
47	2	129155-51521	BUSH, RACK	1	1	1	1				
48	2	129155-51530	SPACER	1	1	1	1				
49	2	129155-51540	CIRCLIP	1	1	1	1				
50	2	129155-51550	PINION, CONTROL	3	3	3	3				
51	2	122117-51560	SCREW	3	3	3	3				
51-1	2	129100-51570	SCREW	3	3	3	3				N
				(A=E/#43125)	(B=E/#46340)	(C=E/#61300)	(D=E/#61031)				
52	2	174307-51560	PINION	3	3	3	3				
53	2	129155-51570	PLUG, M12	1	1	1	1				
54	2	129155-51580	O-RING	1	1	1	1				
55	2	129155-51591	SPRING, RACK	1	1	1	1				
56	2	129155-51600	SHIM SET, ADJUSTING	3	3	3	3				
75	2	129155-51700	COVER	1	1	1	1				
75-1	2	129155-51701	COVER	1	1	1	1				N
				(A=E/#43125)	(B=E/#46340)	(C=E/#52515)	(D=E/#52767)				
76	2	129155-51710	GASKET	1	1	1	1				

Remarks  
(1)GOVERNOR ASSY(FIG.15)IS  
INCORPORATED IN THIS FUEL  
INJECTION PUMP ASSY(REF.NO.1,2).

Fig.14. FUEL INJECTION PUMP

(A)=3TNE84-KAH  
(B)=3TNE84T-KAH  
(C)=3TNE84-EKAH

(D)=3TNE84T-EKAH  
(E)=  
(F)=

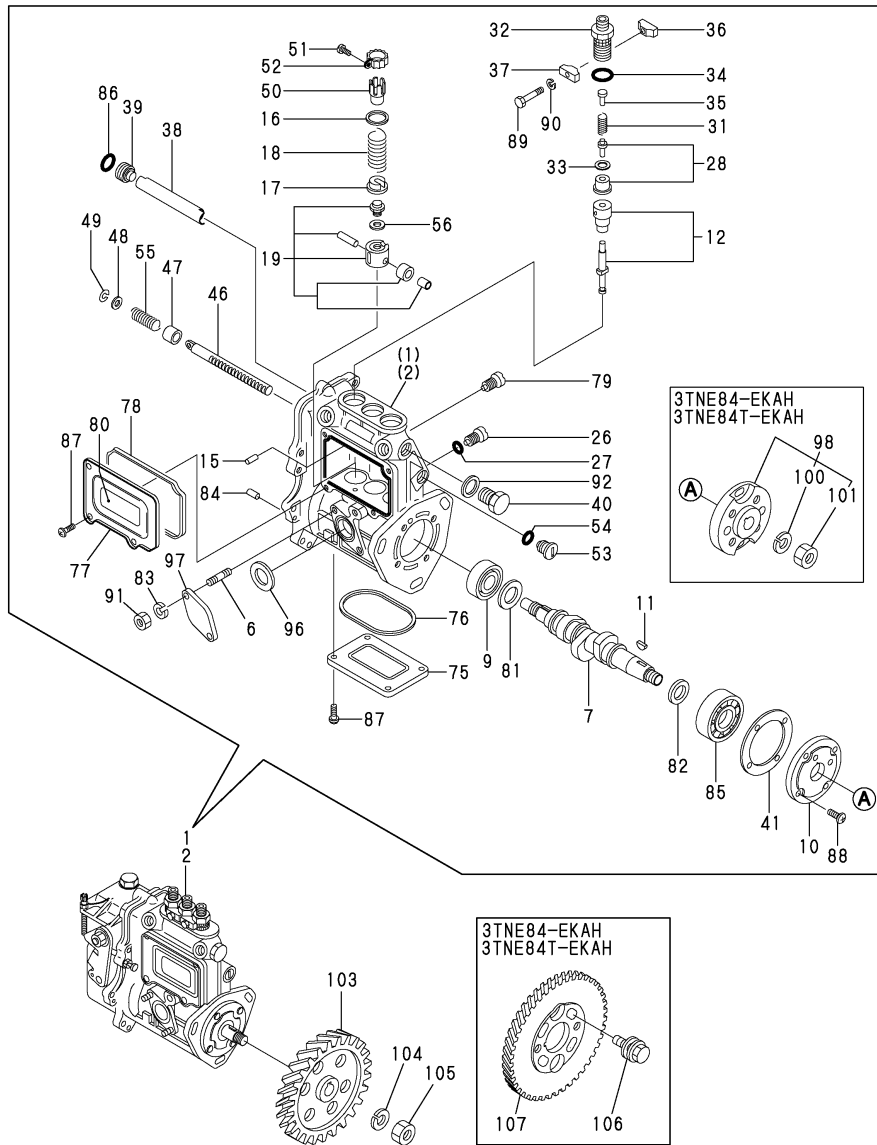

No.	Lev.	Parts No.	Description	Qty						I	R
				(A)	(B)	(C)	(D)	(E)	(F)		
76-1	2	129155-51711	GASKET	1	1	1	1				N
		(A=E/#43125) (B=E/#46340) (C=E/#58642) (D=E/#58663)									
77	2	129155-51750	COVER	1	1	1	1				
77-1	2	129155-51751	COVER	1	1	1	1				N
		(A=E/#43125) (B=E/#46340) (C=E/#52515) (D=E/#52767)									
78	2	129155-51760	GASKET	1	1	1	1				
78-1	2	129155-51761	GASKET	1	1	1	1				N
		(A=E/#43125) (B=E/#46340) (C=E/#77113) (D=E/#78826)									
79	2	129155-51790	STOOPER, RACK	1	1	1	1				
80	2	129156-51910	LABEL, CAUTION	1	1	1	1				
81	2	129155-51930	SPACER, T=3.25	1	1	1	1				
82	2	129155-51940	SPACER, T=1.5	1	1	1	1				
83	2	22217-060000	WASHER, SPRING 6	2	2	2	2				
84	2	22351-050010	PIN, SPRING 5.0X10	2	2	2	2				
85	2	24101-063034	BEARING, BALL 6303	1	1	1	1				
86	2	24341-000160	O-RING, 1AS16.0	1	1	1	1				
87	2	26022-050102	SCREW, M5X10	8	8	8	8				
87-1	3	26022-050122	SCREW, M5X12	8	8	8	8				N
		(A=E/#43125) (B=E/#46340) (C=E/#52515) (D=E/#52767)									
88	2	26022-060162	SCREW, M6X16	4	4	4	4				
89	2	26116-050302	BOLT, M5X 30 PLATED	2	2	2	2				
90	2	22217-050000	WASHER, SPRING 5	2	2	2	2				
91	2	26716-060002	NUT, M6	2	2	2	2				
92	2	22190-160002	WASHER, SEAL 16	1	1	1	1				
96	2	129155-52050	GASKET	1	1	1	1				
96-1	2	129155-52051	GASKET	1	1	1	1				N
		(A=E/#43125) (B=E/#46340) (C=E/#77113) (D=E/#78826)									
97	2	129100-52200	COVER	1	1	1	1				
98	2	129208-54500	FLANGE ASSY			1	1				
100	3	22217-120000	WASHER, SPRING 12			1	1				
101	3	26716-120002	NUT, M12			1	1				
103	1	129150-25900	GEAR, PUMP	1	1						
104	1	22217-120000	WASHER, SPRING 12	1	1						
105	1	26716-120002	NUT, M12	1	1						
106	1	129150-25301	BOLT			4	4				
107	1	129150-25931	GEAR, PUMP			1	1				

Remarks  
(1)GOVERNOR ASSY(FIG.15)IS  
INCORPORATED IN THIS FUEL  
INJECTION PUMP ASSY(REF.NO.1,2).

Fig.15. GOVERNOR

(A)=3TNE84-KAH  
(B)=3TNE84T-KAH  
(C)=3TNE84-EKAH

(D)=3TNE84T-EKAH  
(E)=  
(F)=

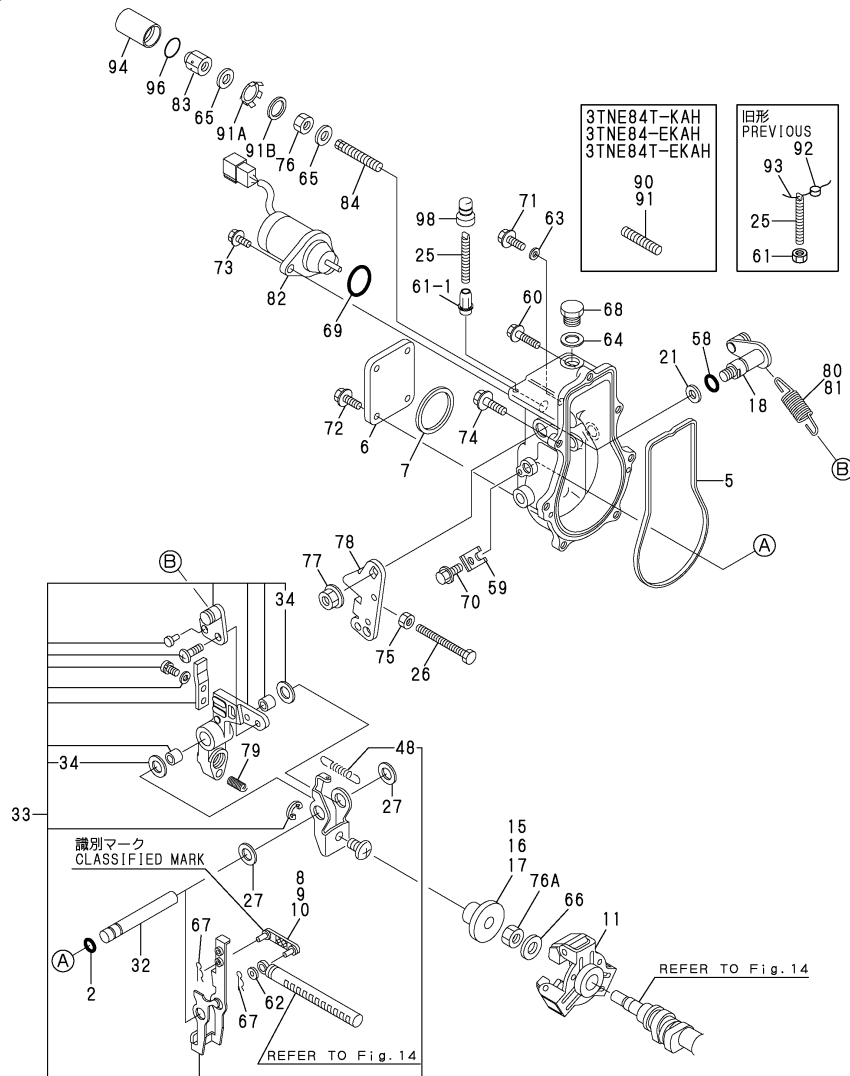

No.	Lev.	Parts No.	Description	Q'ty						I	R
				(A)	(B)	(C)	(D)	(E)	(F)		
2	2	129155-51280	O-RING, S6	1	1	1	1				
5	2	129052-61050	GASKET	1	1	1	1				
5-1	2	129052-61051	GASKET	1	1	1	1				N
6	2	129052-61060	COVER, GOVERNOR CASE	1	1	1	1				
7	2	129052-61070	GASKET	1	1	1	1				
7-1	2	129052-61071	GASKET	1	1	1	1				N
8	2	129155-61120	LINK, L=30 MARK 0	1	1	1	1				1
9	2	129155-61130	LINK, L=31 MARK 1	1	1	1	1				1
10	2	129155-61140	LINK, L=30.5 MARK 05	1	1	1	1				1
11	2	129155-61201	WEIGHT ASSY,GOVERNOR	1	1						
11-1	2	129155-61202	WEIGHT ASSY,GOVERNOR	1	1						R
11A	2	129486-61200	WEIGHT ASSY,GOVERNOR			1	1				
11A-1	2	129486-61201	WEIGHT ASSY,GOVERNOR			1	1				R
15	2	129155-61341	SLEEVE	1	1	1	1				2
16	2	129155-61350	SLEEVE, L=24.9	1	1	1	1				2
17	2	129155-61360	SLEEVE, L=25.2	1	1	1	1				2
18	2	129100-61400	SHAFT ASSY	1	1	1	1				
21	2	129155-61430	SPACER	1	1	1	1				
25	2	129155-61450	BOLT, LIMITER	1	1	1	1				
26	2	129155-61460	BOLT, IDLE	1	1	1	1				
27	2	129155-61480	SPACER ASSY	2	2	2	2				
32	2	129052-61390	SHAFT	1	1	1	1				
33	2	129052-61500	LEVER ASSY, GOVERNOR	1	1						
33-1	2	119908-61501	LEVER ASSY, GOVERNOR	1	1						N
33A	2	119908-61500	LEVER ASSY, GOVERNOR			1	1				
33A-1	2	119908-61501	LEVER ASSY, GOVERNOR			1	1				N
34	3	174307-51700	SHIM SET	2	2	2	2				
48	3	129052-61540	SPRING, SET	1	1	1	1				
48-1	3	129486-61540	SPRING, SET	1	1	1	1				S
58	2	129155-61830	O-RING, S10	1	1	1	1				
59	2	119660-61901	RETAINER, SHAFT	1	1	1	1				
60	2	129155-61950	BOLT	1	1	1	1				
61	2	124550-66370	NUT, M6	1	1	1	1				
61-1	2	129209-61370	NUT, M6	1	1	1	1				S
62	2	22117-040000	WASHER, 4	1	1	1	1				
63	2	22190-060002	WASHER, SEAL 6	1	1						
63-1	2	22190-060003	SEAL WASER 6	1	1	1	1				N
64	2	22190-100002	WASHER, SEAL 10	1	1	1	1				
65	2	22190-120002	WASHER, SEAL 12	2	2	2	2				
66	2	22287-120000	WASHER, 12	1	1	1	1				
67	2	22372-040000	PIN, SNAP 4	2	2	2	2				
68	2	23887-100002	PLUG, 10	1	1	1	1				

Remarks  
(1)SELECTION USE PARTS:CERTAIN THE CLASSIFICATION MARK, THEN PLACE YOUR ORDER.(REFER TO ILLUSTRATION)  
(2)SELECTION USE PARTS.  
(3)REPAIR PART.

Fig.15. GOVERNOR

(A)=3TNE84-KAH  
(B)=3TNE84T-KAH  
(C)=3TNE84-EKAH

(D)=3TNE84T-EKAH  
(E)=  
(F)=

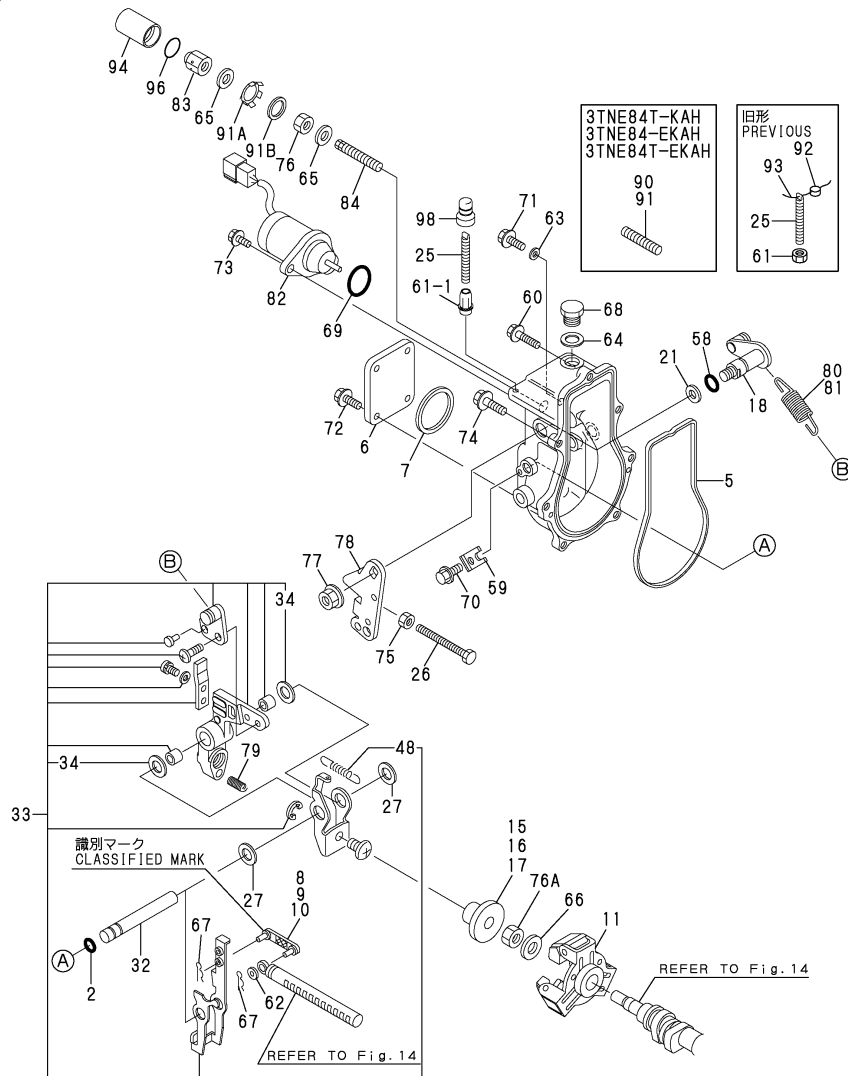

No.	Lev.	Parts No.	Description	Q'ty						I	R
				(A)	(B)	(C)	(D)	(E)	(F)		
69	2	24341-000280	O-RING, 1AS28.0	1	1	1	1				
69-1	2	158552-61900	O-RING	1	1	1	1				N
		(A=EXXXXX) (B=EXXXXX) (C=EXXXXX) (D=EXXXXX)									
70	2	26106-060102	BOLT, M6X 10 PLATED	1	1	1	1				
71	2	26106-060102	BOLT, M6X 10 PLATED	1	1	1	1				
72	2	26106-060102	BOLT, M6X 10 PLATED	4	4	4	4				
73	2	26106-060142	BOLT, M6X 14 PLATED	2	2	2	2				
74	2	26106-060202	BOLT, M6X 20 PLATED	6	6	6	6				
75	2	26756-060002	NUT, LOCK M6	1	1	1	1				
76	2	26776-120002	NUT, LOCK M12	1	1	1	1				
76-1	3	26736-120002	NUT, M12	1	1	1	1				S
		(A=E/#43125) (B=E/#46340) (C=E/#64640) (D=E/#64698)									
76A	2	26776-120002	NUT, LOCK M12	1	1	1	1				
77	2	26366-080002	NUT, M8	1	1	1	1				
78	2	129100-61440	LEVER, CONTROL	1	1	1	1				
79	2	129100-61650	SPRING, CONTROLLER	1	1	1	1				
80	2	171353-61710	SPRING, GOVERNOR	1		1					
81	2	129489-61700	SPRING, GOVERNOR		1		1				
82	2	119653-77950	SOLENOID, STOP	1	1	1	1				
83	2	26687-120002	NUT, CAP M12	1	1						
83A	2	129100-61930	NUT, CAP					1	1		
83A-1	2	129209-61930	NUT, CAP					1	1		R
		(C=E/#71034) (D=E/#71111)									
84	2	129100-61450	LIMITER ASSY, FUEL	1							
90	2	129155-61470	BOLT, CONTROL		1						
91	2	120323-61470	BOLT, CONTROL			1	1				
91A	1	129209-61970	PLATE			1	1				W
		(C=E/#71034) (D=E/#71111)									
91B	1	23414-120016	GASKET, 12X1.0			1	1				W
		(C=E/#71034) (D=E/#71111)									
92	1	135210-61090	LEAD	1	1	1	1				Z
		(C=E/#67397) (D=E/#67935)									
93	1	22451-060000	WIRE, 0.6	1	1	1	1				Z
		(C=E/#67397) (D=E/#67935)									
94	1	129209-61960	CASE			1	1				W 3
		(C=FROM 1ST) (D=FROM 1ST)									
96	1	24311-000150	O-RING, 1AP15.0			1	1				W
		(C=E/#67397) (D=E/#67935)									
98	1	119285-66650	CAP, HIGH-IDLE			1	1				W
		(C=E/#67397) (D=E/#67935)									

Remarks

- (1)SELECTION USE PARTS:CERTAIN THE CLASSIFICATION MARK, THEN PLACE YOUR ORDER.(REFER TO ILLUSTRATION)
- (2)SELECTION USE PARTS.
- (3)REPAIR PART.

Fig.16. FUEL INJECTION VALVE

(A)=3TNE84-KAH  
(B)=3TNE84T-KAH  
(C)=3TNE84-EKAH

(D)=3TNE84T-EKAH  
(E)=  
(F)=

No.	Lev.	Parts No.	Description	Q'ty						I	R
				(A)	(B)	(C)	(D)	(E)	(F)		
1	1	729503-53100	VALVE ASSY,INJECTION	1	1						
1-1	1	729609-53100	VALVE ASSY,INJECTION (C=E/#60402)			1					N
2	1	729503-53200	VALVE ASSY,INJECTION		1		1				
3	2	129503-53000	VALVE ASSY,INJECTION	3	3						
3-1	2	129609-53000	VALVE ASSY,INJECTION (C=E/#60402)			3					N
6	2	129503-53050	VALVE ASSY,INJECTION		3		3				
9	2	114250-53080	NUT, NOZZLE D16.95	3	3	3	3				
13	2	114250-53120	SPRING, NOZZLE	3	3	3	3				
14	2	114250-53130	SEAT, SPRING	3	3	3	3				
15	2	114250-53140	PLATE	3	3	3	3				
16	2	114250-53210	PIN	6	6	6	6				
17	2	114250-53400	SHIM SET	3	3	3	3				
24	1	119305-59120	RETAINER, PIPE	2		2					
27	2	129150-59131	BOLT, M4X14	2		2					
28	1	129150-59120	RETAINER, PIPE		1		1				
31	2	129150-59131	BOLT, M4X14		2		2				
32	1	129052-59810	PIPE ASSY, INJECTION	1		1					
33	1	129211-59810	PIPE ASSY, INJECTION		1		1				
37	1	129052-59820	PIPE ASSY, INJECTION	1		1					
38	1	129211-59820	PIPE ASSY, INJECTION		1		1				
42	1	129052-59830	PIPE ASSY, INJECTION	1		1					
43	1	129211-59830	PIPE ASSY, INJECTION		1		1				
47	1	103854-39140	BOLT, PIPE JOINT	1	1	1	1				
48	1	101304-59020	JOINT, PIPE 12	1	1	1	1				
49	1	22190-120002	WASHER, SEAL 12	2	2	2	2				
50	1	124066-59100	CLIP, HOSE 8	7	7						
50-1	1	124066-59100	CLIP, HOSE 8 (A=E/#43125) (B=E/#46340)	5	5	5	5				K
51	1	121250-59550	PIPE, FUEL D8X120	2	2	2	2				
52	1	119840-59500	PIPE ASSY, RETURN (A=E/#43125) (B=E/#46340)	1	1	1	1				W
52B	2	124066-59100	CLIP, HOSE 8 (A=E/#43125) (B=E/#46340)	2	2	2	2				W
53	1	119840-59570	JOINT	1	1	1	1				
54	1	129150-59580	CAP	1	1	1	1				
55	1	129100-59951	VALVE ASSY, CHECK	1	1	1	1				
55-1	1	119813-59950	VALVE ASSY, CHECK (A=E/#43125) (B=E/#46340) (C=E/#77130) (D=E/#78826)	1	1	1	1				N
63	1	23414-120000	GASKET, 12X1.0	2	2						
63-1	1	22190-120002	WASHER, SEAL 12 (A=E/#43125) (B=E/#46340)	2	2	2	2				N

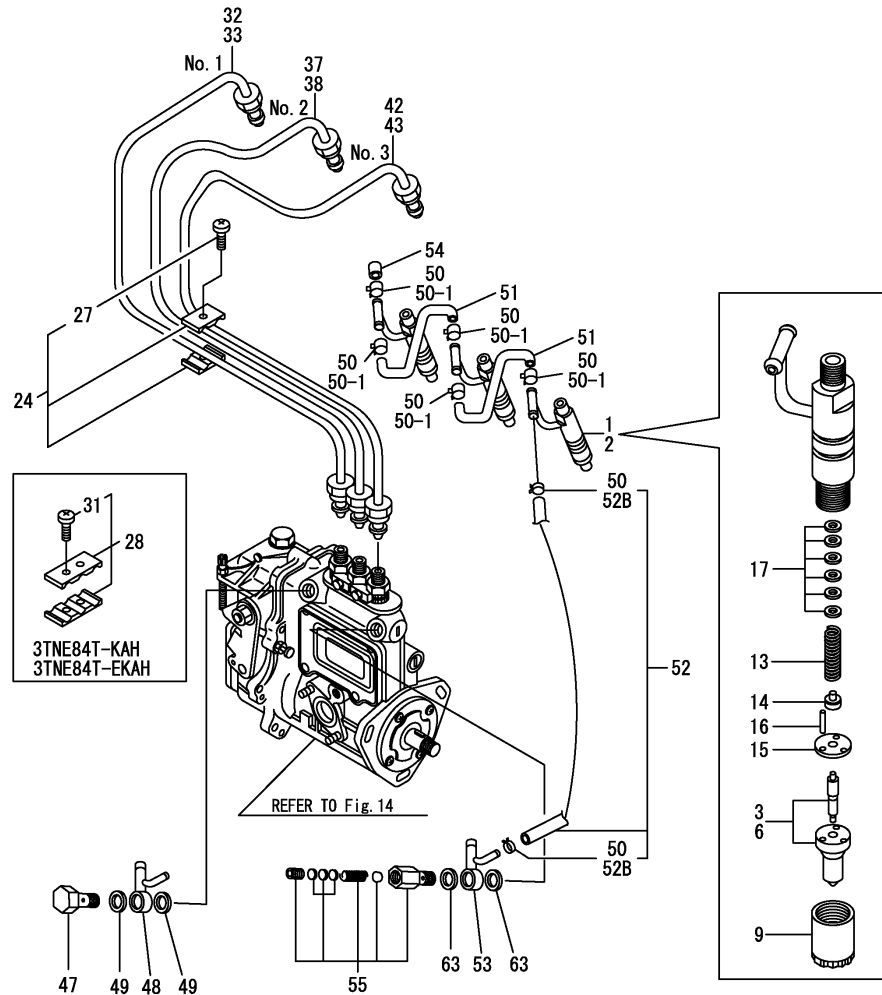
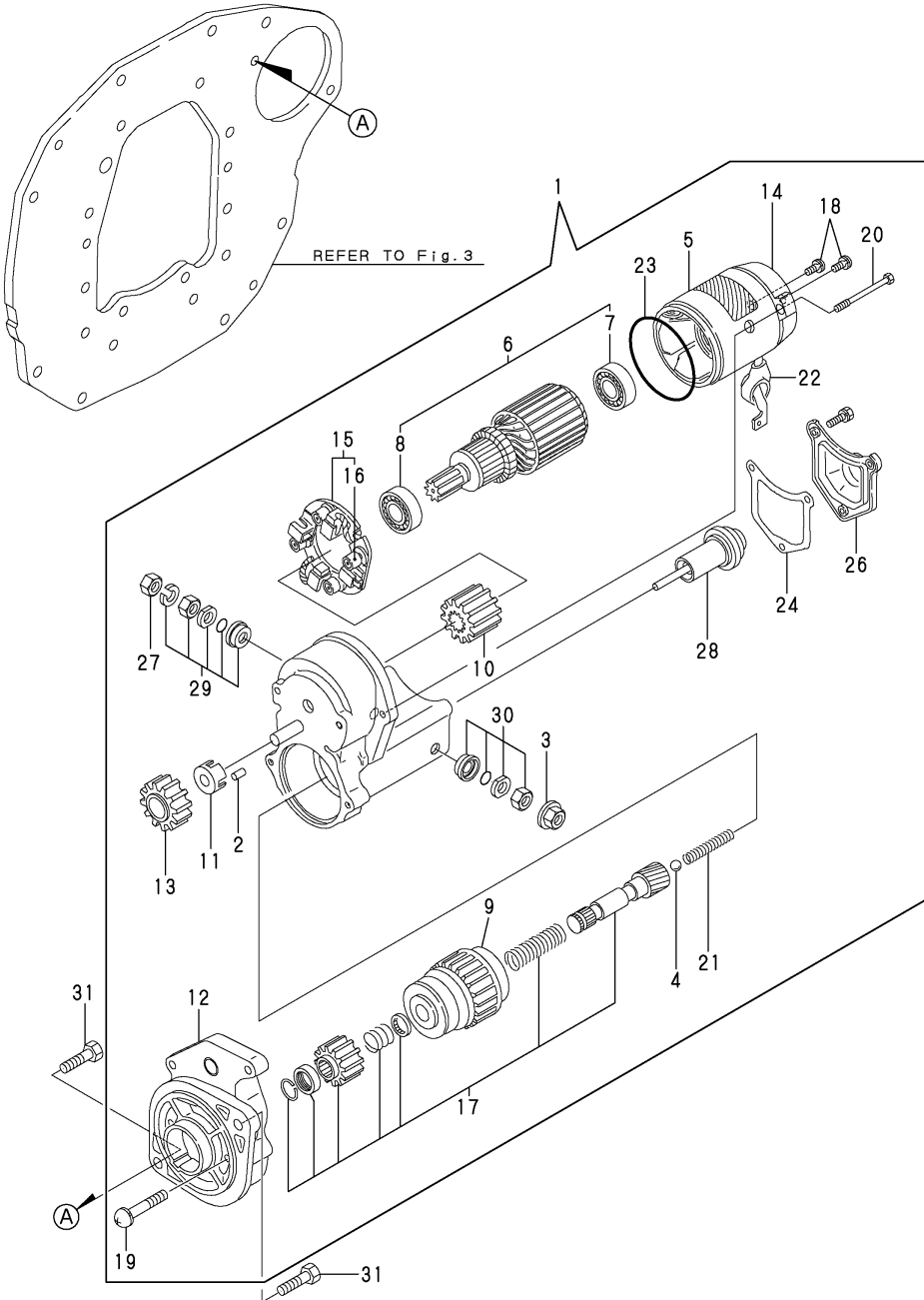

Fig.17. STARTING MOTOR

(A)=3TNE84-KAH  
(B)=3TNE84T-KAH  
(C)=3TNE84-EKAH

(D)=3TNE84T-EKAH  
(E)=  
(F)=



No.	Lev.	Parts No.	Description	Qty						I	R
				(A)	(B)	(C)	(D)	(E)	(F)		
1	1	129429-77011	STARTER ASSY	1	1	1	1				
2	2	X0283060061	ROLLER	5	5	5	5				
3	2	X9490561370	NUT	1	1	1	1				
4	2	X9491200240	BALL	1	1	1	1				
5	2	129429-77210	YOKE ASSY	1	1	1	1				
6	2	129429-77220	ARMATURE ASSY	1	1	1	1				
7	3	129429-77230	BEARING	1	1	1	1				
8	3	129129-77240	BEARING	1	1	1	1				
9	2	129429-77240	STARTER	1	1	1	1				
10	2	129429-77250	PINION ASSY	1	1	1	1				
11	2	129129-77260	RETAINER	1	1	1	1				
12	2	129429-77260	HOUSING	1	1	1	1				
13	2	129129-77270	PINION	1	1	1	1				
14	2	129429-77270	FRAME	1	1	1	1				
15	2	129429-77280	HOLDER ASSY	1	1	1	1				
16	3	129429-77290	SPRING	4	4	4	4				
17	2	129429-77300	SWITCH ASSY	1	1	1	1				
18	2	129429-77310	SCREW	2	2	2	2				
19	2	129429-77320	SCREW	2	2	2	2				
20	2	129429-77330	BOLT	2	2	2	2				
21	2	129129-77340	SPRING	1	1	1	1				
22	2	129429-77340	CAP	1	1	1	1				
23	2	129129-77350	O-RING	2	2	2	2				
24	2	129429-77350	GASKET	1	1	1	1				
26	2	129429-77360	COVER	1	1	1	1				
27	2	129129-77370	NUT	1	1	1	1				
28	2	129429-77370	PLUNGER	1	1	1	1				
29	2	129429-77380	STARTER KIT	1	1	1	1				
30	2	129429-77390	STARTER KIT	1	1	1	1				
31	1	26116-120252	BOLT, M12X 25 PLATED	2	2	2	2				



Fig.18. GENERATOR

(A)=3TNE84-KAH  
(B)=3TNE84T-KAH  
(C)=3TNE84-EKAH

(D)=3TNE84T-EKAH  
(E)=  
(F)=

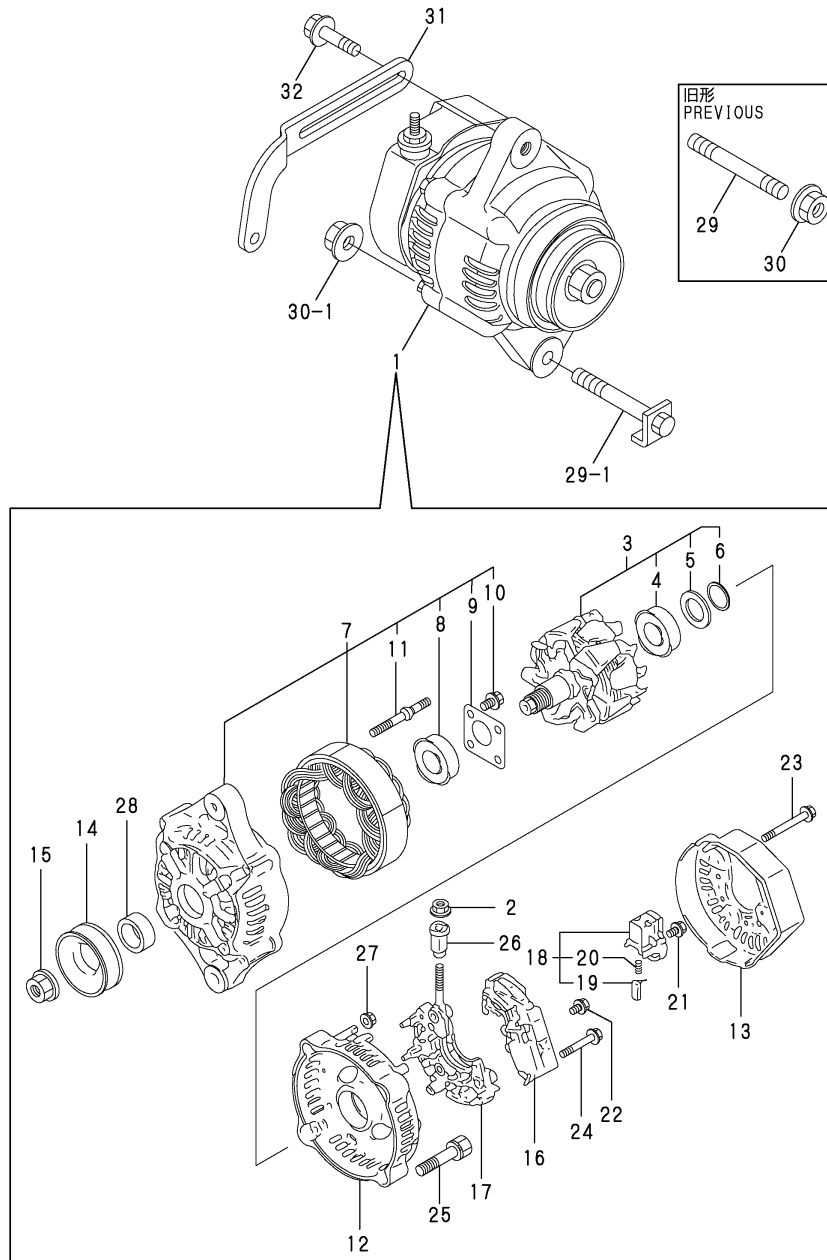

No.	Lev.	Parts No.	Description	Q'ty						I	R
				(A)	(B)	(C)	(D)	(E)	(F)		
1	1	119620-77201	GENERATOR, 40A	1	1	1	1				
2	2	X9490561001	NUT	1	1	1	1				
3	2	119620-77380	ROTOR ASSY	1	1	1	1				
4	3	119620-79240	BEARING, BALL	1	1	1	1				
4-1	3	123501-79240	BEARING, BALL	1	1	1	1				N
		(A=E/XXX) (B=E/XXX) (C=E/XXX) (D=E/XXX)									
5	3	119620-79250	COVER	1	1	1	1				
6	3	119620-79360	WASHER, THRUST	1	1	1	1				
7	2	119620-77421	FRAME ASSY, DRIVE	1	1	1	1				
8	3	119620-79200	BEARING, BALL	1	1	1	1				
9	3	119620-79210	PLATE, RETAINER	1	1	1	1				
10	3	119620-79220	SCREW	4	4	4	4				
11	3	119620-79230	STUD	2	2	2	2				
12	2	119620-77440	FRAME ASSY	1	1	1	1				
13	2	119620-77450	COVER	1	1	1	1				
14	2	119620-77461	PULLEY	1	1	1	1				
15	2	119620-77471	NUT	1	1	1	1				
16	2	119620-77710	REGULATOR ASSY	1	1	1	1				
17	2	119620-79260	HOLDER	1	1	1	1				
18	2	119620-79270	HOLDER, BRUSH	1	1	1	1				
19	3	119620-77480	BRUSH ASSY	2	2	2	2				
20	3	119620-79280	SPRING	2	2	2	2				
21	2	119620-79290	SCREW	6	6	6	6				
22	2	119620-79300	SCREW	1	1	1	1				
23	2	119620-79310	BOLT	3	3	3	3				
24	2	119620-79320	SCREW	2	2	2	2				
25	2	119620-79330	BOLT	2	2	2	2				
26	2	119620-79340	BUSH, INSULATION	1	1	1	1				
27	2	119620-79350	NUT	2	2	2	2				
28	2	119620-77490	COLLAR	1	1	1	1				
29	1	129795-01900	STUD	1	1						
29-1	1	129211-77250	BOLT, GENERATOR	1	1						N
		(A=E/#41461) (B=E/#41506)									
29-2	1	119833-77253	BOLT, GENERATOR	1	1	1	1				N
		(A=E/#43125) (B=E/#46340)									
30	1	26366-100002	NUT, M10	1	1						
30-1	1	129612-77260	NUT, ALTERNATOR	1	1	1	1				R
		(A=E/#41461) (B=E/#41506)									
31	1	129100-77330	ADJUSTER	1	1	1	1				
32	1	119810-77340	BOLT, ADJUSTER	1	1	1	1				

Fig.19. GASKET SET & TOOLS

(A)=3TNE84-KAH  
(B)=3TNE84T-KAH  
(C)=3TNE84-EKAH

(D)=3TNE84T-EKAH  
(E)=  
(F)=

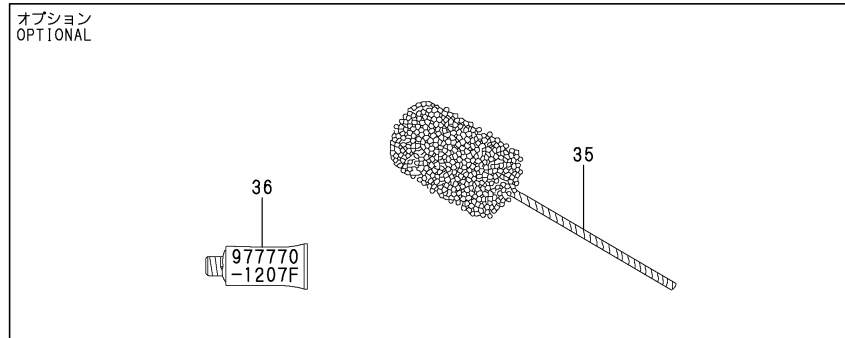
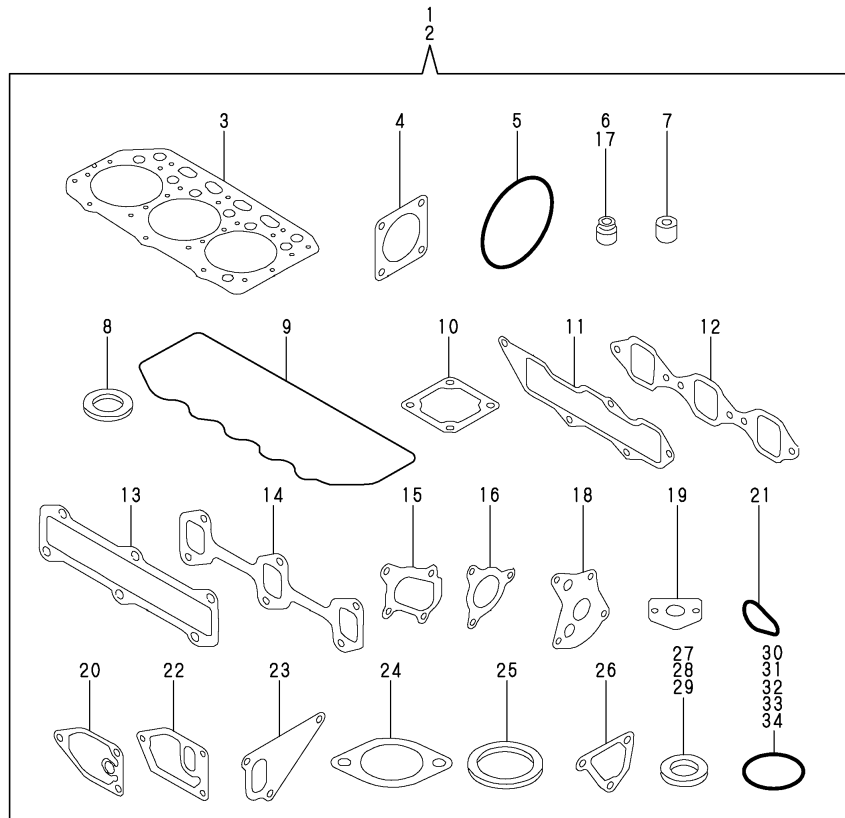

No.	Lev.	Parts No.	Description	Q'ty						I	R
				(A)	(B)	(C)	(D)	(E)	(F)		
1	1	729230-92600	GASKET SET	1		1					1
2	1	729230-92610	GASKET SET		1			1			1
3	2	129002-01331	GASKET, HEAD	1	1	1	1				
4	2	124240-01883	GASKET	1	1	1	1				
5	2	121850-51960	O-RING	1	1	1	1				
6	2	124460-11340	SEAL, VALVE STEM	3	3	3	3				
7	2	119625-11870	PROTECTOR, NOZZLE	3	3	3	3				
8	2	119625-11880	SEAT, NOZZLE	3	3	3	3				
9	2	129150-11310	GASKET, BONNET	1	1	1	1				
10	2	129150-77511	GASKET	1	1	1	1				
11	2	129001-12110	GASKET, MANIFOLD	1		1					
12	2	129150-12111	GASKET, MANIFOLD		1		1				
13	2	129001-13110	GASKET	1		1					
14	2	129150-13110	GASKET		1		1				
15	2	129403-18091	GASKET		1		1				
16	2	129477-18101	GASKET		1		1				
17	2	121400-11340	SEAL, VALVE STEM	3	3	3	3				
18	2	129150-32020	GASKET, PUMP	1	1	1	1				
19	2	129150-35041	GASKET	1	1	1	1				
19-1	1	129150-35042	GASKET	1	1	1	1				N
		(A=E/#43125) (B=E/#46340) (C=E/#78449) (D=E/#78826)									
20	2	129150-35111	GASKET	1		1					
21	2	129120-35110	GASKET		1		1				
22	2	129120-35121	GASKET		1		1				
23	2	129100-42020	GASKET, WATER PUMP	1	1						
23-1	2	129486-42021	GASKET, WATER PUMP	1	1	1	1				N
		(A=E/#43125) (B=E/#46340)									
24	2	129795-49551	GASKET	1	1	1	1				
25	2	129150-49811	GASKET, THERMOSTAT	1	1	1	1				
26	2	129100-49840	GASKET	1	1	1	1				
27	2	129155-52050	GASKET	1	1	1	1				
28	2	23414-080000	GASKET, 8X1.0	2	2						
28-1	2	22190-080003	WASHER, SEAL 8	2	2	2	2				N
		(A=E/#43125) (B=E/#46340)									
29	2	23414-100000	GASKET, 10X1.0	2	2	2	2				
30	2	24311-000120	O-RING, 1AP12.0	3	3	3	3				
31	2	24311-000160	O-RING, 1AP16.0	2	2	2	2				
32	2	24311-000320	O-RING, 1AP32.0	2	2	2	2				
33	2	24341-000240	O-RING, 1AS24.0	1	1	1	1				
34	2	24341-000500	O-RING, 1AS50.0	1	1	1	1				
35	1	129400-92420	HONE	1	1	1	1				1
36	1	977770-1207F	GASKET.LIQUID	1	1	1	1				1

Remarks  
(1)OPTIONAL.

## Parts No. Index

Parts No.	Fig. No.	Ref. No.
101304-59020	16	48
103854-39140	16	47
105010-39140	12	11
106500-44810	8	53
114250-39450	12	13 -1
114250-53080	16	9
114250-53120	16	13
114250-53130	16	14
114250-53140	16	15
114250-53210	16	16
114250-53400	16	17
119131-18320	7	8
	8	56
119260-34810	11	30
119285-66650	15	98
119305-59120	16	24
119609-32040	2	15 -1
119620-77201	18	1
119620-77380	18	3
119620-77421	18	7
119620-77440	18	12
119620-77450	18	13
119620-77461	18	14
119620-77471	18	15
119620-77480	18	19
119620-77490	18	28
119620-77710	18	16
119620-79200	18	8
119620-79210	18	9
119620-79220	18	10
119620-79230	18	11
119620-79240	18	4
119620-79250	18	5
119620-79260	18	17
119620-79270	18	18
119620-79280	18	20
119620-79290	18	21
119620-79300	18	22
119620-79310	18	23
119620-79320	18	24
119620-79330	18	25
119620-79340	18	26
119620-79350	18	27
119620-79360	18	6
119625-11870	4	25
	5	45
	19	7
119625-11880	4	11
	5	46
	19	8

Parts No.	Fig. No.	Ref. No.
119625-11900	4	13
	5	47
119653-77950	15	82
119660-61901	15	59
119717-51500	14	46 -1
119802-11280	4	39 -1
	5	44 -1
119802-13600	7	6 -1
119802-13710	7	9 -1
119810-51040	14	7
119810-77340	18	32
119813-59950	16	55 -1
119833-77253	18	29 -2
119840-59500	16	52
119840-59570	16	53
119908-61500	15	33 A
119908-61501	15	33 -1
		33 A-1
120130-11860	4	26
	5	31
120323-61470	15	91
121250-59550	16	51
121400-11340	4	22
	5	28
	19	17
121450-01560	2	7
121450-42450	13	33
121550-23200	10	35
121550-49111	13	28
121850-21680	10	11
121850-51960	2	14
	19	5
122117-51560	14	51
122710-51090	14	11
123501-79240	18	4 -1
123900-13630	7	7 -1
		7 -2
		10 -1
		10 -2
124066-59100	16	50
		50 -1
		52 B
124160-01751	2	8
	4	57
	5	63
124160-01910	1	8
124160-11360	4	55
	5	61
124160-21501	10	12
124160-39140	12	12

Parts No.	Fig. No.	Ref. No.
124160-39450	12	13
124223-39900	12	14
124240-01871	2	9
124240-01883	2	10
	19	4
124250-49351	13	35
124395-49840	13	26 -1
124460-11340	4	23
	5	29
	19	6
124465-44950	13	34
124550-21600	10	16
124550-51350	14	33
124550-51370	14	34
124550-59830	12	15
124550-66370	15	61
124574-44761	13	20
124736-07900	4	5
	5	5
124950-51190	14	18
129001-01250	1	14 -1
129001-02930	1	18
129001-11700	4	7
129001-12100	6	1
129001-12110	6	4
	19	11
129001-13100	7	1
129001-13110	7	3
	19	13
129001-21000	10	1
129001-21100	10	1 -1
129001-32001	11	1
129001-35300	11	43
129001-42002	13	1
129001-42003	13	1 -1
129001-42040	13	37
129001-91840	2	23
129001-91841	2	23 -1
129001-91870	3	15
129002-01331	1	34
	19	3
129002-22081	10	17
129002-22090	10	23
129002-22500	10	19
129002-22900	10	39
129002-22910	10	45
129002-22950	10	41
129002-22960	10	25
		47
129012-13300	8	1

Parts No.	Fig. No.	Ref. No.
129012-13301	8	1 -1A
129012-13410	8	2
129012-13411	8	2 -1A
129012-33000	11	47
129012-49030	13	30
129052-59810	16	32
129052-59820	16	37
129052-59830	16	42
129052-61050	15	5
129052-61051	15	5 -1
129052-61060	15	6
129052-61070	15	7
129052-61071	15	7 -1
129052-61390	15	32
129052-61500	15	33
129052-61540	15	48
129100-01580	3	1
		16
	10	2
129100-01640	3	17
129100-01730	3	5
129100-11100	4	17
	5	23
129100-11110	4	18
129100-11111	4	18 -1
129100-11130	5	25
129100-11350	4	44
	5	50
129100-11351	4	44 -1
	5	50 -1
129100-23910	10	38
129100-25061	9	10
129100-42020	13	13
	19	23
129100-49840	13	26
	19	26
129100-51570	14	51 -1
129100-52200	14	97
129100-59951	16	55
129100-61400	15	18
129100-61440	15	78
129100-61450	15	84
129100-61650	15	79
129100-61930	15	83 A
129100-77330	18	31
129103-01530	2	6
129103-49301	13	14
129120-33040	11	48
129120-33051	11	49
129120-33060	11	50

## Parts No. Index

Parts No.	Fig. No.	Ref. No.
129120-35001	11	51
129120-35110	11	55
	19	21
129120-35121	11	56
	19	22
129120-42350	13	17
129120-77501	6	16
129122-12060	6	10
129122-12100	6	3
129122-12211	6	14
129122-44480	2	13
	13	29
129129-14580	9	3
129129-77240	17	8
129129-77260	17	11
129129-77270	17	13
129129-77340	17	21
129129-77350	17	23
129129-77370	17	27
129131-21591	10	13
129135-01770	3	7
129135-34800	11	29
129135-35090	11	35
129136-34820	11	31
129137-18010	8	3
129139-12050	6	9
129139-12200	6	13
129139-13100	7	2
129139-39030	12	5
129139-39601	12	19
129150-01200	1	33
129150-01600	3	2
129150-01650	3	18
129150-02020	1	10
129150-02450	9	4
129150-02870	1	38
129150-02930	1	30
129150-02940	1	35
129150-03020	4	46
	5	52
129150-03070	4	47
	5	53
129150-03080	4	48
	5	54
129150-03090	4	1
	5	1
129150-03100	2	12
129150-11230	4	36
	5	41
129150-11280	4	31

Parts No.	Fig. No.	Ref. No.
129150-11280	5	36
129150-11290	4	32
	5	37
129150-11310	4	51
	5	57
	19	9
129150-11370	4	24
	5	30
129150-11750	4	38
	5	43
129150-11810	4	27
	5	32
129150-12111	6	5
	19	12
129150-13110	7	4
	19	14
129150-14101	9	7
129150-14200	9	1
129150-14400	9	2
129150-23600	10	36
129150-23610	10	51
129150-25101	9	11
129150-25301	14	106
129150-25900	14	103
129150-25920	9	14
129150-25931	14	107
129150-32020	11	27
	19	18
129150-35041	11	34
	19	19
129150-35042	11	34 -1
	19	19 -1
129150-35101	11	40
129150-35111	11	41
	19	20
129150-35170	11	42
	57	
129150-35350	11	44
	59	
129150-39450	12	1
129150-49360	13	36
129150-49811	13	25
	19	25
129150-59120	16	28
129150-59131	16	27
	31	
129150-59580	16	54
129150-77511	6	17
	19	10
129150-91400	2	27

Parts No.	Fig. No.	Ref. No.
129155-11241	4	28
	5	33
129155-11260	4	29
	5	34
129155-11270	4	30
	5	35
129155-51020	14	6
129155-51050	14	9
129155-51051	14	9 -1
129155-51060	14	10
129155-51140	14	15
129155-51180	14	17
129155-51200	14	19
129155-51270	14	26
129155-51280	14	27
	15	2
129155-51320	14	31
129155-51340	14	32
129155-51370	14	35
129155-51380	14	36
129155-51390	14	37
129155-51400	14	38
129155-51410	14	39
129155-51420	14	40
129155-51450	14	41
129155-51500	14	46
129155-51521	14	47
129155-51530	14	48
129155-51540	14	49
129155-51550	14	50
129155-51570	14	53
129155-51580	14	54
129155-51591	14	55
129155-51600	14	56
129155-51700	14	75
129155-51701	14	75 -1
129155-51710	14	76
129155-51711	14	76 -1
129155-51750	14	77
129155-51751	14	77 -1
129155-51760	14	78
129155-51761	14	78 -1
129155-51790	14	79
129155-51930	14	81
129155-51940	14	82
129155-52050	14	96
	19	27
129155-52051	14	96 -1
129155-61120	15	8
129155-61130	15	9

Parts No.	Fig. No.	Ref. No.
129155-61140	15	10
129155-61201	15	11
129155-61202	15	11 -1
129155-61341	15	15
129155-61350	15	16
129155-61360	15	17
129155-61430	15	21
129155-61450	15	25
129155-61460	15	26
129155-61470	15	90
129155-61480	15	27
129155-61830	15	58
129155-61950	15	60
129156-51910	14	80
129202-22300	10	29
129208-51060	14	10 A
129208-54500	14	98
129209-61370	15	61 -1
129209-61930	15	83 A-1
129209-61960	15	94
129209-61970	15	91 A
129211-59810	16	33
129211-59820	16	38
129211-59830	16	43
129211-77250	18	29 -1
129350-49560	13	22
129400-01520	2	5
129400-92420	19	35
129403-18091	8	49
	19	15
129403-18720	8	4
129403-18750	8	5
129403-18770	8	6
129403-18780	8	15
129403-18800	8	24
129403-39610	12	20
129403-42380	13	17 -1
		18 -1
129403-49050	13	31 A
129403-49060	13	31
129407-35300	11	58
129418-18320	8	56 -1
129418-32000	11	14
129429-77011	17	1
129429-77210	17	5
129429-77220	17	6
129429-77230	17	7
129429-77240	17	9
129429-77250	17	10
129429-77260	17	12

## Parts No. Index

Parts No.	Fig. No.	Ref. No.
129429-77270	17	14
129429-77280	17	15
129429-77290	17	16
129429-77300	17	17
129429-77310	17	18
129429-77320	17	19
129429-77330	17	20
129429-77340	17	22
129429-77350	17	24
129429-77360	17	26
129429-77370	17	28
129429-77380	17	29
129429-77390	17	30
129457-49800	13	24 -1
129457-49801	13	24 -2
129470-11080	5	21
129470-11090	5	22
129477-18101	8	50
	19	16
129486-01670	3	20
129486-42021	13	13 -1
	19	23 -1
129486-42140	13	38 -1
129486-61200	15	11 A
129486-61201	15	11 A-1
129486-61540	15	48 -1
129489-61700	15	81
129503-53000	16	3
129503-53050	16	6
129505-51300	14	28
129506-51100	14	12
129535-18100	8	50 -1
129550-42350	13	18
129553-39650	11	68
129574-49800	13	24
129609-53000	16	3 -1
129612-77260	18	30 -1
129792-39410	11	62
129795-01780	3	19
129795-01800	2	4
129795-01900	18	29
129795-01950	2	11
129795-02411	1	17
129795-11120	4	19
	5	24
129795-11180	4	20
	5	26
129795-21661	10	10
129795-49551	13	23
	19	24

Parts No.	Fig. No.	Ref. No.
129956-49230	13	31 B
135210-61090	15	92
158552-61900	15	69 -1
171051-01921	1	9
171058-01630	3	8
171058-01640	3	9
171058-01641	3	9 -1
171340-21650	10	9
171353-61710	15	80
171440-44740	13	19
174307-51170	14	16
174307-51560	14	52
174307-51700	15	34
194990-22050	8	51
		52
22117-040000	15	62
22190-060002	15	63
22190-060003	15	63 -1
22190-080002	2	25
		26
	12	15 B
		15 B-2
		16
		17 -1
		17 -3
22190-080003	12	15 B-1
	19	28 -1
	12	18 -1
22190-100002	15	64
	15	65
22190-120002	15	65
	16	49
		63 -1
		92
22190-160002	14	92
22217-050000	14	90
22217-060000	14	83
22217-120000	14	100
		104
22252-000260	10	30
22287-120000	15	66
22351-030010	11	69
22351-040010	10	8
22351-050010	14	84
22351-060012	4	40
	5	12
22372-040000	15	67
22451-060000	15	93
22512-070140	9	8
23000-022000	12	21
	13	32

Parts No.	Fig. No.	Ref. No.
23000-041000	6	11
23000-060000	6	12
23414-080000	12	16 -1
		17
	19	28
23414-100000	11	53
	12	18
	19	29
23414-120000	16	63
23414-120016	15	91 B
23871-010000	1	13
23871-020000	5	16
	13	12
23871-030000	5	17
	13	10
23876-010000	1	13 -1
23876-020000	5	16 -1
	13	12 -1
23876-030000	5	17 -1
	13	10 -1
23881-100002	11	54
23887-100002	15	68
24101-063034	14	85
24311-000120	4	56
	5	62
	19	30
24311-000150	15	96
24311-000160	2	15
	11	45
		60
	19	31
24311-000320	2	16
	4	58
	5	64
	19	32
24311-240100	11	32
24314-000160	12	22
24316-000160	12	22 -1
24321-000300	13	38
24341-000160	14	86
24341-000240	2	29
	19	33
24341-000280	15	69
24341-000500	4	53
	5	59
	19	34
25132-003800	13	16 -1
25132-003900	13	16
26014-060252	13	21
26014-080252	8	54

Parts No.	Fig. No.	Ref. No.
26022-050102	14	87
26022-050122	14	87 -1
26022-060162	14	88
26106-060102	15	70
		71
		72
26106-060142	15	73
26106-060162	2	30
	12	23
26106-060202	15	74
26106-080102	8	55
26106-080122	2	17
	12	24
26106-080142	4	6
	5	6
	9	9
26106-080162	2	18
		19
	3	11
	4	54
	5	60
	6	15
	13	39
26106-080202	2	20
	6	6
	11	46
	13	27
26106-080252	3	12
	4	41
	5	48
	6	7
	11	33
		61
26106-080352	3	21
	6	18
	11	39
26106-080402	7	6
26106-080452	2	21
	3	13
	9	15
26106-080502	4	42
	5	49
26106-080552	2	22
26106-080602	3	14
	13	15
26106-080802	6	8
	7	7
26116-050302	14	89
26116-120252	17	31
26206-100202	3	3

## Parts No. Index

Parts No.	Fig. No.	Ref. No.
26206-100252	3	4
26216-060202	4	15
	5	18
26216-080402	7	9
26216-080802	7	10
26226-080182	4	39
	5	44
26306-080002	2	24 -1
	7	5 -1
	8	51 -1
		52 -1
26366-060002	4	43
	5	14
26366-080002	2	24
	7	5
	15	77
26366-100002	18	30
26450-060252	11	28
26687-120002	15	83
26716-060002	14	91
26716-120002	14	101
		105
26736-120002	15	76 -1
26756-060002	15	75
26776-120002	15	76
		76 A
27231-500000	1	14
27241-120000	1	15
27241-220000	5	19
27241-300000	1	16
27241-400000	4	16
	5	20
27310-080001	4	21
	5	27
719810-01500	2	1
729002-01560	1	1
729012-01560	1	2
729012-51370	14	2
729012-51450	14	2 A
729132-11521	4	44 -2
	5	50 -2
729202-11710	5	7
729211-51360	14	1
729211-51460	14	1 A
729230-92600	19	1
729230-92610	19	2
729402-11650	4	35
	5	40
729402-23100	10	31
729503-53100	16	1

Parts No.	Fig. No.	Ref. No.
729503-53200	16	2
729609-53100	16	1 -1
977770-1207F	19	36
X0283060061	17	2
X9490561001	18	2
X9490561370	17	3
X9491200240	17	4
XNB139815	8	32
XNB139825	8	20
XNB139826	8	27
XNB139827	8	35

Parts No.	Fig. No.	Ref. No.
-----------	----------	----------

Parts No.	Fig. No.	Ref. No.
-----------	----------	----------