

0CB10-M51900EN

Directions for the Parts Catalog.

1. This Parts Catalog shows both standard and optional parts.
2. Parts may change without prior notice.
3. The following is an example of the Parts Catalog format.

REF.	LEV.	PARTS NO.	DESCRIPTION	Q'TY						I	R
				(A)	(B)	(C)	(D)	(E)	(F)		
1	1	729595-51390	FUEL INJECTION PUMP	1	1	1	1	1			1
1-1	1	729595-51391	FUEL INJECTION PUMP	1	1	1	1	1		N	1
		(A=E00185) (B=E00200)									
3	2	26022-060162	SCREW M 6X 16	9	9	9	9	9			
3-1	2	26022-060162	SCREW M 6X 16	4	4	4	4	4		K	
		(A=E00156) (B=E00156) (C=E00156) (D=E00156) (E=E00156)									
4	2	129470-51040	CAMSHAFT	1	1	1	1	1			
5	2	122710-51050	BEARING, ROLLER	2	2	2	2	2			
6	2	129470-51060	RETAINER	1	1	1	1	1			

Remarks
(1) BOOST COMPEMSATOR TYPE. OPTIONAL PART, TO E00155,(4JH-DT, 4JH-DTZ

① Ref. No.

The Ref. No. listed may not be in accordance with the illustration Ref. No.

(Ex.) Illustration No.

List Ref No.

1

1

(Before change)

1-1

(After change)

For interchangeable symbols N, R and K, illustrations for new parts may be abbreviated.

② Lev. (Level)

Level indication

The numbers below indicate the level of relativity towards the main part.

1 ----- Main parts (Assembly parts)

2 ----- Sub component included in " 1 ".

3 ----- Sub component included in " 2 ".

Note) Parts that are not for sale are partially illustrated but not listed.

③ Interchangeability Symbol

When a part change takes place, one of the following interchangeability symbols is indicated beside the part.

Symbol	Interchangeability	Contents note
N	Old $\begin{matrix} \leftarrow \text{Yes} \\ \text{No} \rightarrow \end{matrix}$ New	New Part is interchangeable for Old Part but Old Part is not interchangeable for New Part.
Q	Old $\begin{matrix} \leftarrow \text{No} \\ \text{Yes} \rightarrow \end{matrix}$ New	New Part is not interchangeable for Old Part but Old Part is interchangeable for New Part.
R	Old $\begin{matrix} \leftarrow \text{Yes} \\ \text{Yes} \rightarrow \end{matrix}$ New	New/ Old Parts are both interchangeable.
S	Old $\begin{matrix} \leftarrow \text{No} \\ \text{No} \rightarrow \end{matrix}$ New	New/ Old Parts are both not interchangeable.
W		Part newly added.
Z		Part discontinued.
F		Not interchangeable by a single part but interchangeable together with related parts.
K		Changes only for used parts quantities.

④ Effective Machine No.

When a part changes, the effective Machine No. will be indicated in the (A)-(F) column.

Product Symbol	Product No.	Product Symbol	Product No.
C	Clutch No. Compressor No.	F	Machine No. (Agricultural Equip.)
D	Drive No.	M	Machine No.
E	Engine No.		

Note 1) A date may follow the symbol. (Ex.) 1996.01

Note 2) "XXXXX" and "ZZZZZ" are for parts that could not be predicted or for engine models that could not be identified.

Note 3) (A=E00185) is the E (Engine Serial Number) for the column (A) model (in this case 4JH-DT) after the parts design change.

⑤ Remarks

Figures or alphabets (symbols) are entered in the remarks column.

The comments (remarks) on parts that are indicated at the bottom of the illustration are the same symbols as those stated above.

Contents

OCB10-M51900

Fig. No. Fig. Name

ENGINE SECTION(3TNE84,88-AGD)

1. CYLINDER BLOCK
2. GEAR HOUSING
3. FLYWHEEL HOUSING & OIL SUMP
4. CYLINDER HEAD & BONNET
5. SUCTION MANIFOLD
6. EXHAUST MANIFOLD
7. CAMSHAFT & DRIVING GEAR
8. CRANKSHAFT & PISTON
9. LUB.OIL SYSTEM
10. COOLING WATER SYSTEM
11. FUEL INJECTION PUMP
12. GOVERNOR
13. FUEL INJECTION VALVE
14. FUEL LINE
15. STARTING MOTOR
16. GENERATOR
17. PULSER
18. ELECTRIC PARTS
19. GASKET SET(OPTIONAL) & TOOL

ENGINE SECTION(4TNE88-AGD)

20. CYLINDER BLOCK
21. GEAR HOUSING
22. FLYWHEEL HOUSING & OIL SUMP

Fig. No. Fig. Name

23. CYLINDER HEAD & BONNET
24. SUCTION MANIFOLD
25. EXHAUST MANIFOLD
26. CAMSHAFT & DRIVING GEAR
27. CRANKSHAFT & PISTON
28. LUB.OIL SYSTEM
29. COOLING WATER SYSTEM
30. FUEL INJECTION PUMP
31. GOVERNOR
32. FUEL INJECTION VALVE
33. FUEL LINE
34. STARTING MOTOR
35. GENERATOR
36. PULSER
37. ELECTRIC PARTS
38. GASKET SET(OPTIONAL) & TOOL

ENGINE SECTION(4TNE84T-AGD)

39. CYLINDER BLOCK
40. GEAR HOUSING
41. FLYWHEEL HOUSING & OIL SUMP
42. CYLINDER HEAD & BONNET
43. SUCTION MANIFOLD
44. EXHAUST MANIFOLD
45. CAMSHAFT & DRIVING GEAR

Contents

OCB10-M51900

Fig. No.	Fig. Name	Fig. No.	Fig. Name
46.	TURBOCHARGER		
47.	CRANKSHAFT & PISTON		
48.	LUB.OIL SYSTEM		
49.	LUB.OIL LINE		
50.	COOLING WATER SYSTEM		
51.	FUEL INJECTION PUMP		
52.	GOVERNOR		
53.	FUEL INJECTION VALVE		
54.	FUEL LINE		
55.	STARTING MOTOR		
56.	GENERATOR		
57.	PULSER		
58.	ELECTRIC PARTS		
59.	GASKET SET(OPTIONA) & TOOL		

Fig.1. CYLINDER BLOCK

(A)=3TNE84-AGD
(B)=3TNE88-AGD
(C)=4TNE88-AGD

(D)=4TNE84T-AGD
(E)=
(F)=

Y00B5190
3, 4TNE84, 88 (T) -AGD

1 シリンダブロック
1 CYLINDER BLOCK

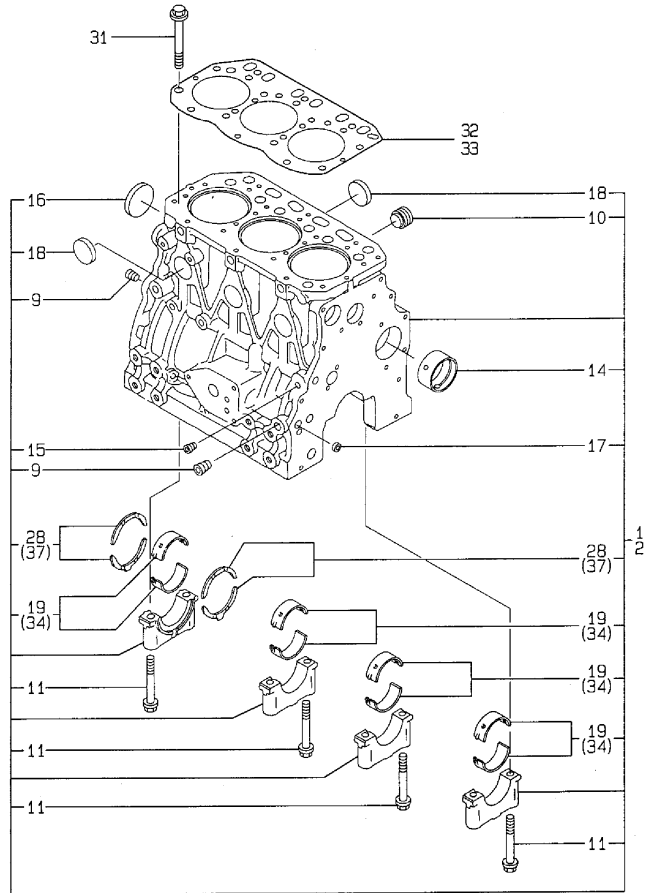

No.	Lev.	Parts No.	Description	Q'ty						I	R
				(A)	(B)	(C)	(D)	(E)	(F)		
1	1	729002-01560	BLOCK ASSY, CYLINDER	1							
2	1	729001-01560	BLOCK ASSY, CYLINDER		1						
9	2	124160-01910	PLUG, PT1/4	3	3						
10	2	171051-01921	PLUG, NPTF1	1	1						
11	2	129150-02020	BOLT, METAL CAP	8	8						
14	2	129795-02411	BUSH, CAMSHAFT	1	1						
15	2	23871-010000	PLUG, R01	1	1						
16	2	27231-500000	PLUG 50	1	1						
17	2	27241-120000	PLUG, 12	2	2						
18	2	27241-300000	PLUG 30	6	6						
19	2	129001-02800	BEARING, MAIN	4	4						
28	2	129150-02930	BEARING, THRUST	2	2						
31	1	129150-01200	BOLT, HEAD	14	14						
32	1	129002-01331	GASKET, HEAD	1							G
33	1	129001-01340	GASKET, HEAD		1						G
34	1	129150-02870	BEARING, 0.25 US	4	4						1
37	1	129150-02940	BEARING, THRUST 0.25	2	2						2

Remarks

- (1) UNDER-SIZE(U.S=0.25)PART.
- (2) OVER-SIZE(O.S=0.25)PART.
- (G) THESE PARTS ARE SOLD BY FIG.19, REF.NO.1,2.

Fig.2. GEAR HOUSING

(A)=3TNE84-AGD
(B)=3TNE88-AGD
(C)=4TNE88-AGD

(D)=4TNE84T-AGD
(E)=
(F)=

Y00B5190
3. 4TNE84, 88 (T) -AGD

ギヤケース
GEAR HOUSING

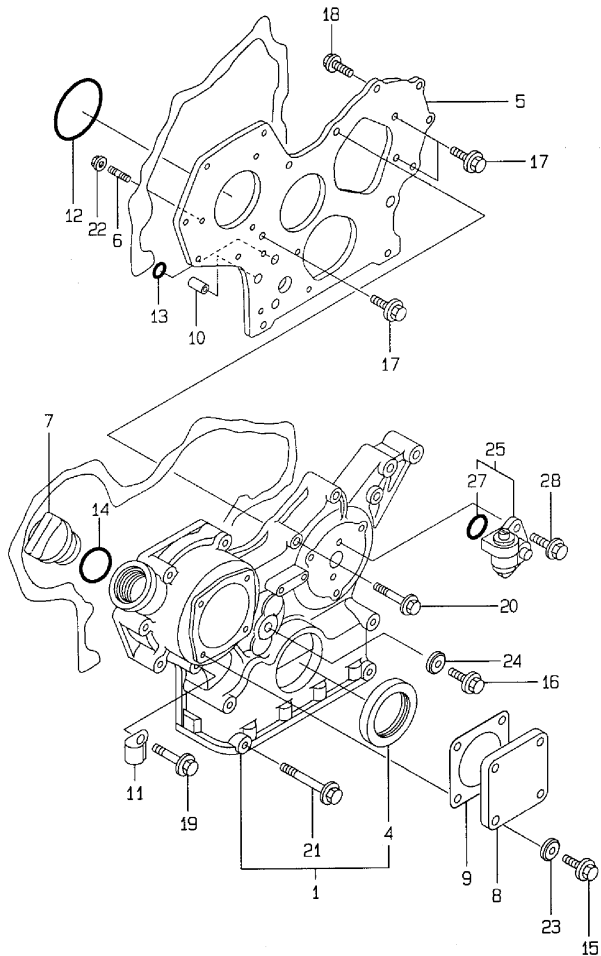

No.	Lev.	Parts No.	Description	Q'ty						I	R
				(A)	(B)	(C)	(D)	(E)	(F)		
1	1	719810-01500	CASE ASSY, GEAR	1	1						
4	2	129795-01800	SEAL, OIL	1	1						
5	1	129400-01520	FLANGE, GEAR CASE	1	1						
6	1	121450-01560	STUD, M8X22	3	3						
7	1	124160-01751	COVER, FILLER	1	1						
8	1	124240-01871	COVER	1	1						
9	1	124240-01883	GASKET	1	1						G
10	1	129795-01950	PIPE, KNOCK L=18	2	2						
11	1	129150-03100	RETAINER, PIPE	1	1						
12	1	121850-51960	O-RING	1	1						G
13	1	24311-000160	O-RING, 1AP16.0	2	2						G
14	1	24311-000320	O-RING, 1AP32.0	1	1						G
15	1	26106-080122	BOLT, M8X 12 PLATED	4	4						
16	1	26106-080162	BOLT, M8X 16 PLATED	1	1						
17	1	26106-080162	BOLT, M8X 16 PLATED	3	3						
18	1	26106-080202	BOLT, M8X 20 PLATED	2	2						
19	1	26106-080452	BOLT, M8X 45 PLATED	6	6						
20	1	26106-080552	BOLT, M8X 55 PLATED	3	3						
21	1	26106-080852	BOLT, M8X 85 PLATED	4	4						
22	1	26366-080002	NUT, M8	3	3						
23	1	22190-080002	WASHER, SEAL 6	4	4						G
24	1	22190-080002	WASHER, SEAL 6	1	1						G
25	1	129150-91400	GEAR	1	1						
27	2	24341-000240	O-RING, 1AS24.0	1	1						G
28	1	26106-060162	BOLT, M6X 16 PLATED	2	2						

Remarks
(G) THESE PARTS ARE SOLD BY FIG.19,
REF.NO.1,2.

Fig.3. FLYWHEEL HOUSING & OIL SUMP

(A)=3TNE84-AGD
(B)=3TNE88-AGD
(C)=4TNE88-AGD

(D)=4TNE84T-AGD
(E)=
(F)=

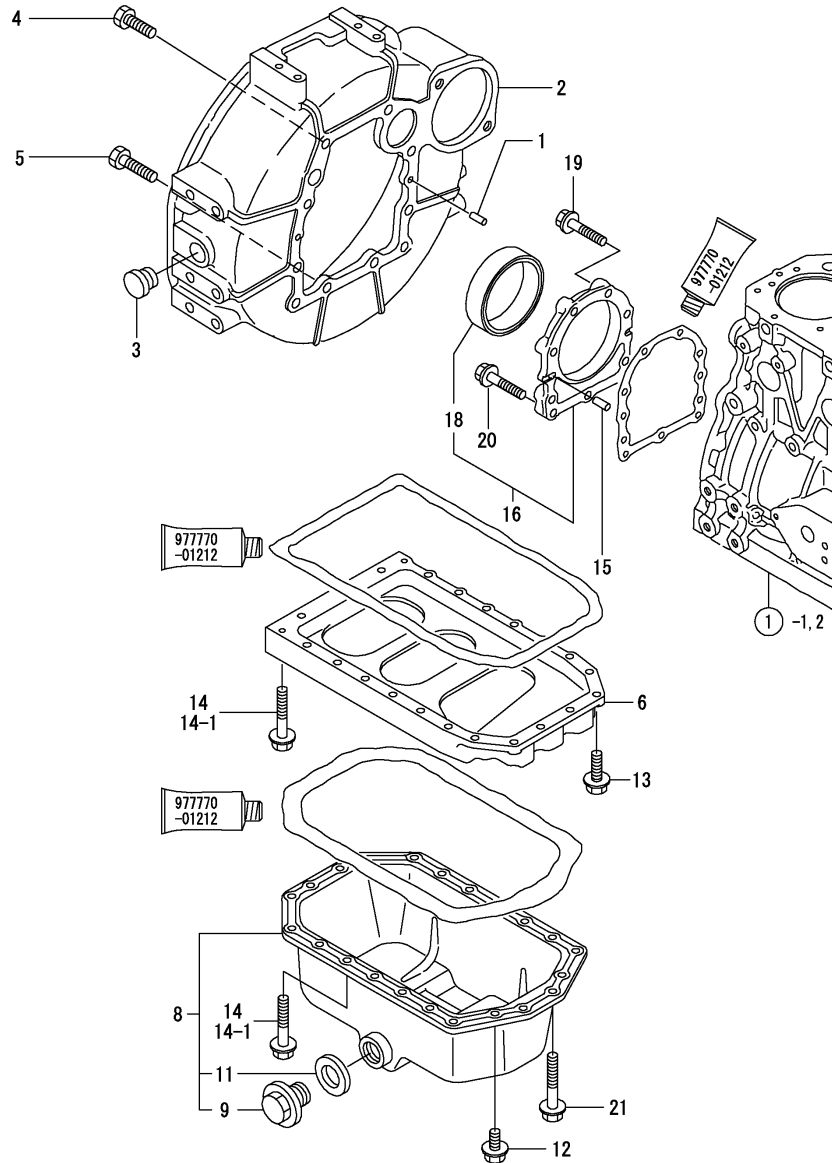

No.	Lev.	Parts No.	Description	Q'ty						I	R
				(A)	(B)	(C)	(D)	(E)	(F)		
1	1	129100-01580	PIN, M8X16	2	2						
2	1	171420-01600	HOUSING, FLYWHEEL	1	1						
3	1	119620-01750	CAP	1	1						
4	1	26206-100252	BOLT, M10X 25 PLATED	6	6						
5	1	26206-100302	BOLT, M10X 30 PLATED	4	4						
6	1	129100-01730	SPACER, OIL SUMP	1	1						
8	1	129100-01770	SUMP ASSY, OIL	1	1						
9	2	119640-01640	PLUG, DRAIN M22	1	1						
11	2	22190-220002	WASHER, SEAL 22	1	1						
12	1	26106-080162	BOLT, M8X 16 PLATED	4	4						
13	1	26106-080252	BOLT, M8X 25 PLATED	2	2						
14	1	26106-080452	BOLT, M8X 45 PLATED	20	20						
14-1	1	26106-080452	BOLT, M8X 45 PLATED	16	16						K
		(A=FROM 1ST) (B=FROM 1ST)									
15	1	129100-01580	PIN, M8X16	2	2						
16	1	129100-01640	CASE ASSY, OIL SEAL	1	1						
18	2	129795-01780	SEAL, OIL	1	1						
19	1	26106-080302	BOLT, M8X 30 PLATED	6	6						
20	1	26106-080352	BOLT, M8X 35 PLATED	3	3						
21	1	26106-080502	BOLT, M8X 50 PLATED	4	4						W
		(A=FROM 1ST) (B=FROM 1ST)									

Fig.4. CYLINDER HEAD & BONNET

(A)=3TNE84-AGD
(B)=3TNE88-AGD
(C)=4TNE88-AGD

(D)=4TNE84T-AGD
(E)=
(F)=

Y0085190
3, 4TNE84, 88 (7) -AGD

4 シリンダヘッド & ボンネット
CYLINDER HEAD & BONNET

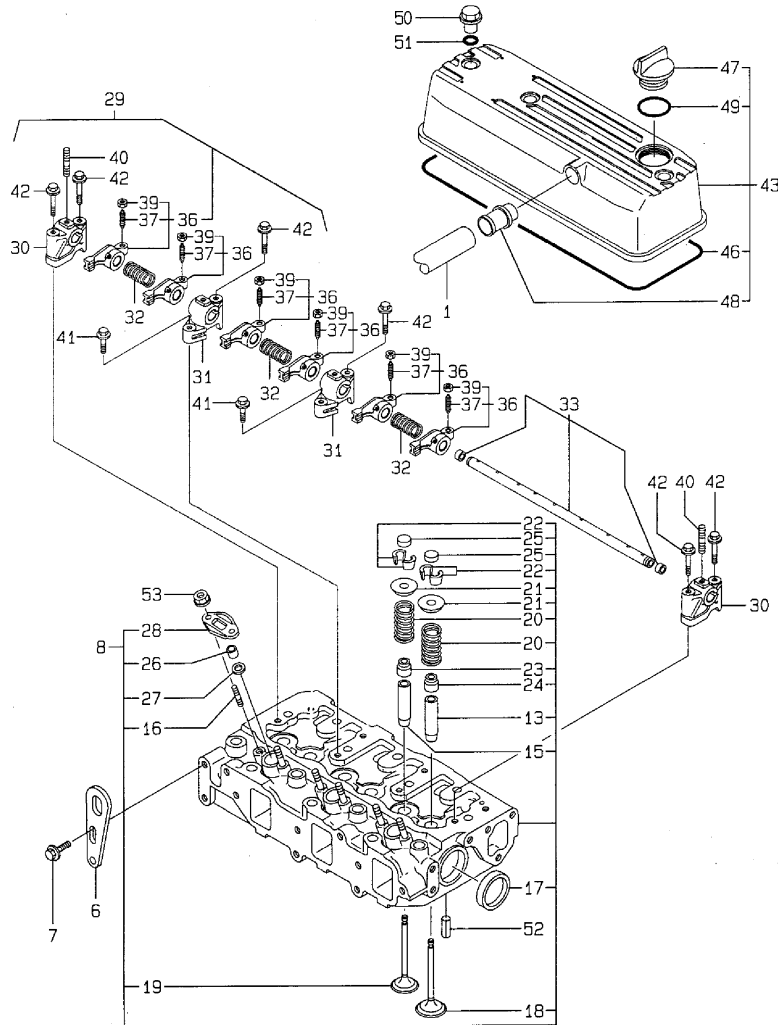

No.	Lev.	Parts No.	Description	Q'ty						I	R
				(A)	(B)	(C)	(D)	(E)	(F)		
1	1	171350-03090	PIPE , BREATHER 900	1	1						
6	1	124736-07900	LIFTER	2	2						
7	1	26106-080142	BOLT, M8X 14 PLATED	4	4						
8	1	129001-11700	HEAD ASSY, CYLINDER	1	1						
13	2	120130-11860	GUIDE, VALVE	3	3						1
15	2	129150-11810	GUIDE, VALVE	3	3						1
16	2	26216-060202	STUD, M6X 20	6	6						
17	2	27241-400000	PLUG, 40	2	2						
18	2	129100-11100	VALVE, INTAKE	3	3						
19	2	129100-11110	VALVE, EXHAUST	3	3						
20	2	129795-11120	SPRING, VALVE	6	6						
21	2	129795-11180	RETAINER, SPRING	6	6						
22	2	27310-080001	COTTER, 8	6	6						
23	2	121400-11340	SEAL, VALVE STEM	3	3						G
24	2	124460-11340	SEAL, VALVE STEM	3	3						G
25	2	129150-11370	CAP, VALVE	6	6						
26	2	119625-11871	PROTECTOR, NOZZLE	3	3						G
27	2	119625-11880	SEAT, NOZZLE	3	3						G
28	2	119625-11900	RETAINER, NOZZLE	3	3						
29	1	129100-11240	SHAFT ASSY, ROCKER	1	1						
30	2	129155-11260	SUPPORT, ROCKER ARM	2	2						
31	2	129155-11270	SUPPORT, ROCKER ARM	2	2						
32	2	129150-11280	SPRING	3	3						
33	2	129150-11290	SHAFT, ROCKER ARM	1	1						
36	2	129100-11650	ARM, ROCKER	6	6						
37	3	129150-11230	SCREW, VALVE ADJUST	6	6						
39	3	129150-11750	NUT, M8	6	6						
40	2	26226-080182	STUD, M8X 18	3	3						
41	1	26106-080252	BOLT, M8X 25 PLATED	2	2						
42	1	26106-080502	BOLT, M8X 50 PLATED	6	6						
43	1	129001-11350	BONNET ASSY, HEAD	1	1						
46	2	129001-11310	GASKET, BONNET	1	1						G
47	2	124160-01751	COVER, FILLER	1	1						
48	2	129001-11340	PIPE , BREATHER	1	1						
49	2	24311-000320	O-RING, 1AP32.0	1	1						G
50	1	124160-11360	KNOB	3	3						
51	1	24311-000120	O-RING, 1AP12.0	3	3						G
52	1	22351-060012	PIN, SPRING 6.0X12	2	2						
53	1	26366-060002	NUT, M6	6	6						

Remarks

- (1) REPAIR PART.
- (G) THESE PARTS ARE SOLD BY FIG.19, REF.NO.1,2.

Fig.5. SUCTION MANIFOLD

(A)=3TNE84-AGD
(B)=3TNE88-AGD
(C)=4TNE88-AGD

(D)=4TNE84T-AGD
(E)=
(F)=

Y00B5190
3, 4TNE84, 88 (T) -AGD

5 キュウキマニホールド
SUCTION MANIFOLD

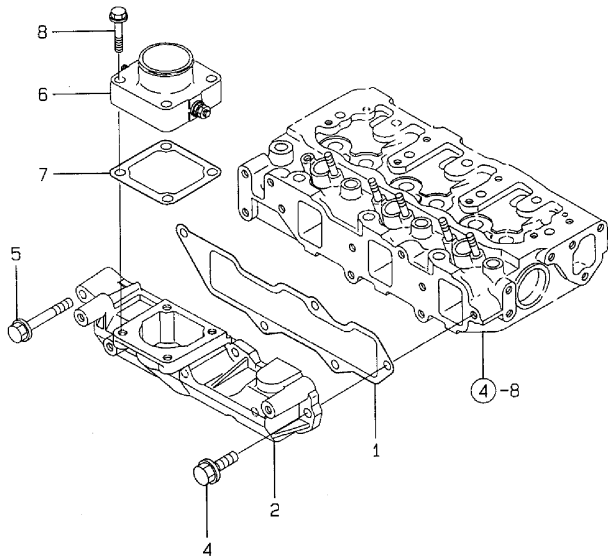

No.	Lev.	Parts No.	Description	Q'ty						I	R
				(A)	(B)	(C)	(D)	(E)	(F)		
1	1	129001-12110	GASKET, MANIFOLD	1	1						G
2	1	129001-12120	MANIFOLD, AIR INTAKE	1	1						
4	1	26106-080202	BOLT, M8X 20 PLATED	4	4						
5	1	26106-080502	BOLT, M8X 50 PLATED	1	1						
6	1	129120-77501	HEATER	1	1						
7	1	129150-77511	GASKET	1	1						G
8	1	26106-080352	BOLT, M8X 35 PLATED	4	4						

Remarks
(G) THESE PARTS ARE SOLD BY FIG.19,
REF.NO.1,2.

Fig.6. EXHAUST MANIFOLD

(A)=3TNE84-AGD
 (B)=3TNE88-AGD
 (C)=4TNE88-AGD

(D)=4TNE84T-AGD
 (E)=
 (F)=

Y00B5190
 3. 4TNE84, 88 (T) -AGD

6 ハイキマニホールド
 EXHAUST MANIFOLD

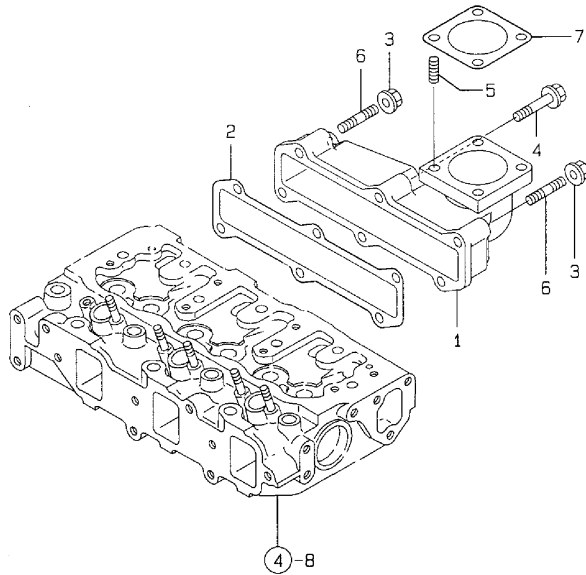

No.	Lev.	Parts No.	Description	Q'ty						I	R
				(A)	(B)	(C)	(D)	(E)	(F)		
1	1	129001-13100	MANIFOLD, EXHAUST	1	1						
2	1	129001-13110	GASKET	1	1						G
3	1	194990-22050	NUT, M8	2	2						
4	1	26106-080402	BOLT, M8X 40 PLATED	4	4						
5	1	26216-080222	STUD, M8X 22	4	4						
6	1	26216-080402	STUD, M8X 40	2	2						
7	1	124701-11911	GASKET, SILENCER	1	1						G

Remarks
 (G) THESE PARTS ARE SOLD BY FIG.19,
 REF.NO.1,2.

Fig.7. CAMSHAFT & DRIVING GEAR

(A)=3TNE84-AGD
(B)=3TNE88-AGD
(C)=4TNE88-AGD

(D)=4TNE84T-AGD
(E)=
(F)=

Y00B5190
3, 4TNE84, 88 (T) -AGD

7 カムシャフト & フドウギヤ
CAMSHAFT & DRIVING GEAR

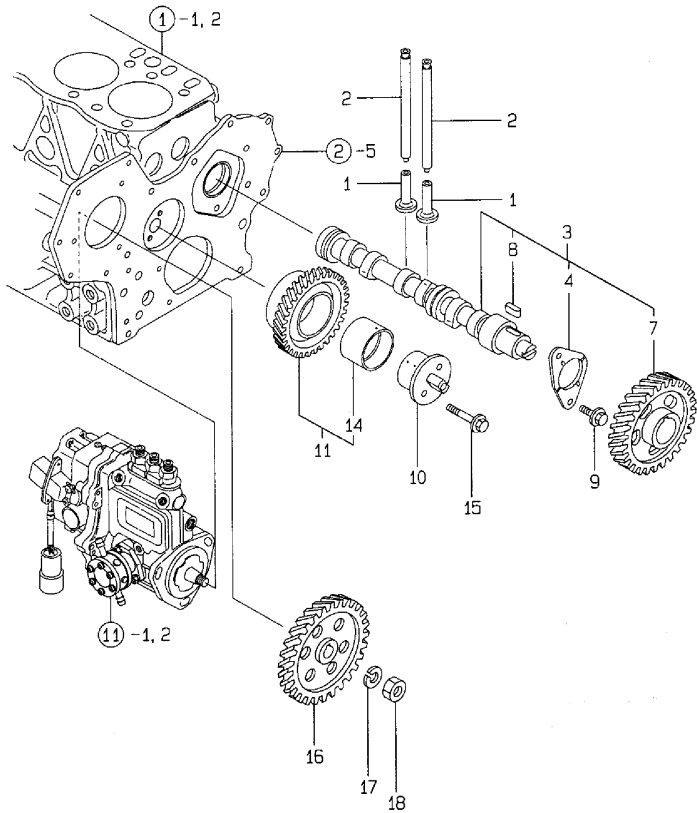

No.	Lev.	Parts No.	Description	Q'ty						I	R
				(A)	(B)	(C)	(D)	(E)	(F)		
1	1	129150-14200	TAPPET	6	6						
2	1	129150-14400	ROD, PUSH L=178	6	6						
3	1	129129-14580	CAMSHAFT ASSY	1	1						
4	2	129150-02450	BEARING, THRUST	1	1						
7	2	129150-14101	GEAR, CAMSHAFT	1	1						
8	2	22512-070140	KEY, 7X 14	1	1						
9	1	26106-080162	BOLT, M8X 16 PLATED	2	2						
10	1	129100-25061	SHAFT, IDLE	1	1						
11	1	129150-25101	GEAR ASSY, IDLE	1	1						
14	2	129150-25920	BUSH, IDLE GEAR	1	1						1
15	1	26106-080452	BOLT, M8X 45 PLATED	2	2						
16	1	129150-25900	GEAR, PUMP	1	1						
17	1	22217-120000	WASHER, SPRING 12	1	1						
18	1	26716-120002	NUT, M12	1	1						

Remarks
(1) REPAIR PART.

Fig.8. CRANKSHAFT & PISTON

(A)=3TNE84-AGD
(B)=3TNE88-AGD
(C)=4TNE88-AGD

(D)=4TNE84T-AGD
(E)=
(F)=

Y00B5190
3, 4TNE84, 88 (T) -AGD

クランクシャフト & ピストン
CRANKSHAFT & PISTON

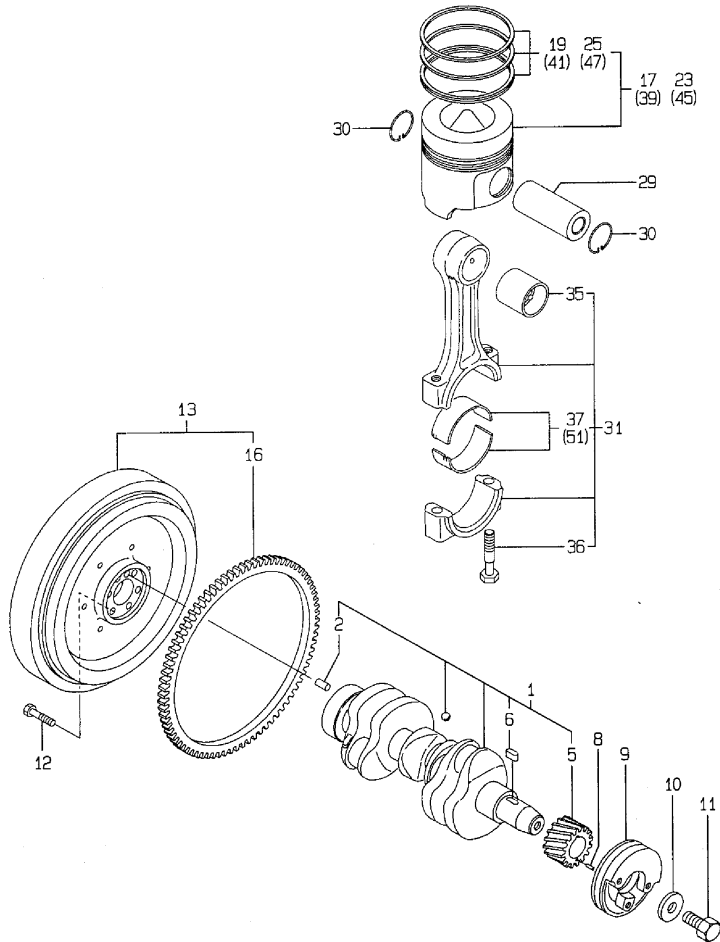

No.	Lev.	Parts No.	Description	Q'ty						I	R
				(A)	(B)	(C)	(D)	(E)	(F)		
1	1	129001-21000	CRANKSHAFT ASSY	1	1						
2	2	129100-01580	PIN, M8X16	1	1						
5	2	129150-21200	GEAR, CRANKSHAFT	1	1						
6	2	22512-070140	KEY, 7X 14	1	1						
8	1	22351-040010	PIN, SPRING 4.0X10	1	1						
9	1	171340-21650	V-PULLEY	1	1						
10	1	129795-21661	WASHER	1	1						
11	1	121850-21680	BOLT	1	1						
12	1	121111-21501	BOLT, FLYWHEEL	6	6						
13	1	171340-21590	FLYWHEEL ASSY	1	1						
16	2	124550-21600	GEAR, RING	1	1						
17	1	129002-22081	PISTON ASSY	3							
19	2	129002-22500	RING SET, PISTON	3							
23	1	129001-22081	PISTON ASSY		3						
25	2	129001-22500	RING SET, PISTON		3						
29	1	129202-22300	PIN, PISTON D26 L70	3	3						
30	1	22252-000260	RING, 26	6	6						
31	1	729402-23100	ROD ASSY, CONNECTING	3	3						
35	2	129100-23910	BEARING, PISTON PIN	3	3						1
36	2	121550-23200	BOLT, CONNECTING ROD	6	6						
37	2	129150-23600	BEARING, CRANK PIN	3	3						
39	1	129002-22900	PISTON ASSY, 0.25 OS	3							2
41	2	129002-22950	RING SET, 0.25 OS	3							2
45	1	129001-22900	PISTON ASSY, 0.25 OS		3						2
47	2	129001-22950	RING SET, 0.25 OS		3						2
51	1	129150-23610	BEARING, 0.25 US	3	3						3

Remarks

- (1) REPAIR PART.
- (2) OVER-SIZE(O.S=0.25)PART.
- (3) UNDER-SIZE(U.S=0.25)PART.

Fig.9. LUB.OIL SYSTEM

(A)=3TNE84-AGD
(B)=3TNE88-AGD
(C)=4TNE88-AGD

(D)=4TNE84T-AGD
(E)=
(F)=

Y0085190
3. 4TNE84, 88 (T) -AGD

9 LUB.OIL SYSTEM
LUB.OIL SYSTEM

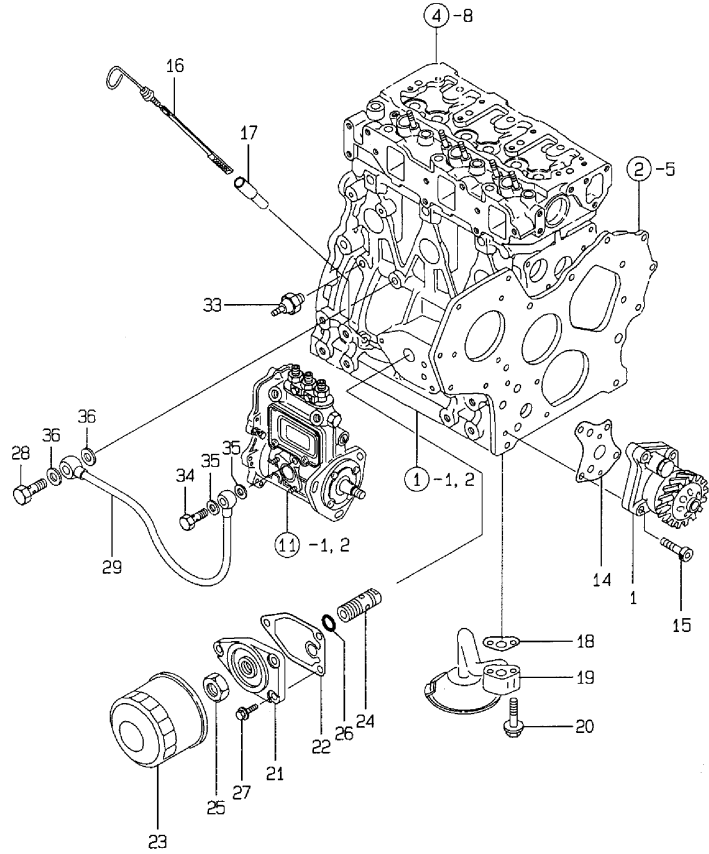

No.	Lev.	Parts No.	Description	Q'ty						I	R
				(A)	(B)	(C)	(D)	(E)	(F)		
1	1	129001-32001	PUMP ASSY, OIL	1	1						
14	1	129150-32020	GASKET, PUMP	1	1						G
15	1	26450-060252	BOLT, M6X 25	4	4						
16	1	129136-34800	DIPSTICK, OIL	1	1						
17	1	121520-34810	GUIDE, DIPSTICK	1	1						
18	1	129150-35041	GASKET	1	1						G
19	1	129100-35301	PIPE ASSY, OIL INLET	1	1						
20	1	26106-080352	BOLT, M8X 35 PLATED	2	2						
21	1	129150-35101	BRACKET, STRAINER	1	1						
22	1	129150-35111	GASKET	1	1						G
23	1	129150-35151	FILTER, D80XL80	1	1						
24	1	129001-35300	BOLT, FILTER	1	1						
25	1	129150-35350	NUT	1	1						
26	1	24311-000160	O-RING, 1AP16.0	1	1						G
27	1	26106-080202	BOLT, M8X 20 PLATED	3	3						
28	1	124160-39140	BOLT, PIPE JOINT M10	1	1						
29	1	129150-39450	PIPE ASSY, OIL	1	1						
33	1	124160-39450	SWITCH, 0.5KG	1	1						
34	1	124550-59820	BOLT, PIPE JOINT M8	1	1						
35	1	23414-080000	GASKET, 8X1.0	2	2						G
36	1	23414-100000	GASKET, 10X1.0	2	2						G

Remarks
(G) THESE PARTS ARE SOLD BY FIG.19,
REF.NO.1,2.

Fig.10. COOLING WATER SYSTEM

(A)=3TNE84-AGD
(B)=3TNE88-AGD
(C)=4TNE88-AGD

(D)=4TNE84T-AGD
(E)=
(F)=

Y00B5190
3, 4TNE84, 88 (7) -AGD

10 CWシステム
COOLING WATER SYSTEM

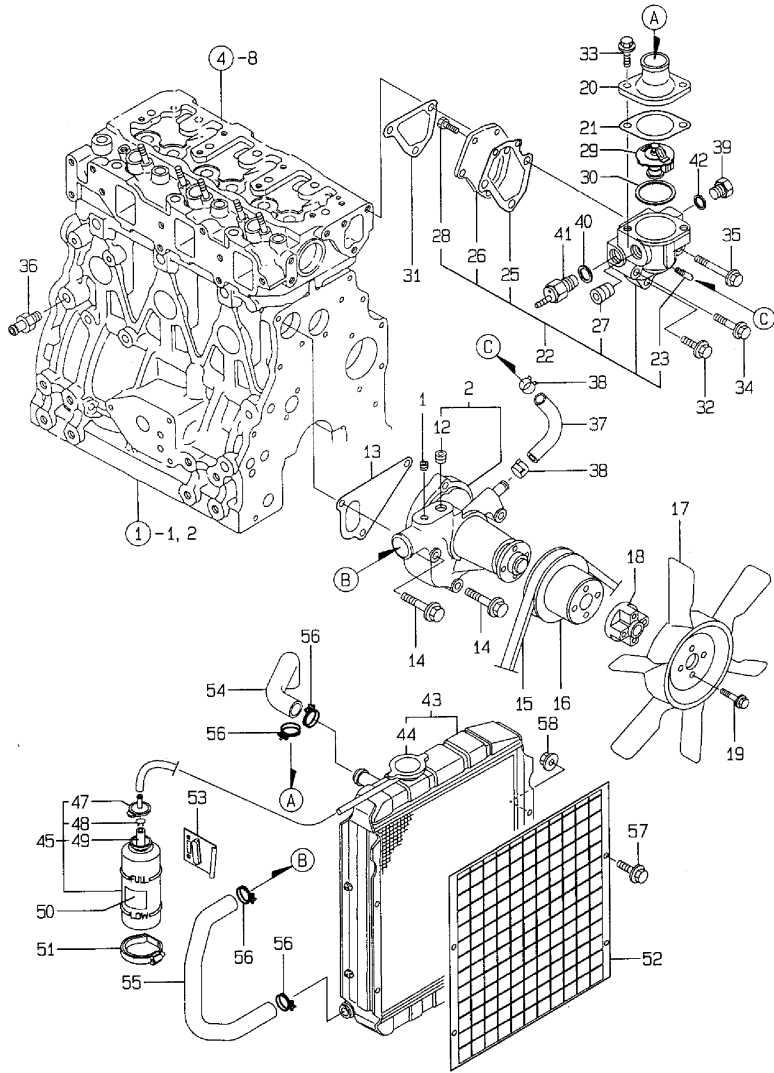

No.	Lev.	Parts No.	Description	Q'ty						I	R
				(A)	(B)	(C)	(D)	(E)	(F)		
1	1	121850-11860	PLUG, PT1/4	1	1						
2	1	129100-42002	PUMP ASSY, WATER	1	1						
12	2	23871-030000	PLUG, R03	1	1						
13	1	129100-42020	GASKET, WATER PUMP	1	1						G
14	1	26106-080602	BOLT, M8X 60 PLATED	3	3						
15	1	124732-42290	V-BELT, AX37	1	1						
16	1	129155-42350	V-PULLEY	1	1						
17	1	171340-44740	FAN, COOLING D335XNF	1	1						
18	1	171353-44760	SPACER, FAN	1	1						
19	1	26106-060352	BOLT, M6X 35 PLATED	4	4						
20	1	129350-49530	COVER, THERMOSTAT	1	1						
21	1	129795-49551	GASKET	1	1						G
22	1	129100-49800	CASE ASSY, THERMOSTAT	1	1						
23	2	124770-11770	JOINT, PIPE PT1/8	1	1						
25	2	129100-49820	GASKET	1	1						
26	2	129100-49830	COVER, THERMOSTAT	1	1						
27	2	23871-030000	PLUG, R03	1	1						
28	2	26116-060162	BOLT, M6X 16 PLATED	2	2						
29	1	129155-49800	THERMOSTAT, 71	1	1						
30	1	129150-49811	GASKET, THERMOSTAT	1	1						G
31	1	129100-49840	GASKET	1	1						G
32	1	26106-080252	BOLT, M8X 25 PLATED	1	1						
33	1	26106-080202	BOLT, M8X 20 PLATED	2	2						
34	1	26106-080502	BOLT, M8X 50 PLATED	1	1						
35	1	26106-080602	BOLT, M8X 60 PLATED	1	1						
36	1	121550-49111	JOINT, PT1/4	1	1						
37	1	129132-49050	PIPE, WATER	1	1						
38	1	23000-016000	CLAMP, 16	2	2						
39	1	121450-42450	PLUG, M16	1	1						
40	1	124465-44950	GASKET, 16	1	1						G
41	1	121250-44901	SWITCH, 110	1	1						
42	1	124465-44950	GASKET, 16	1	1						G
43	1	171420-44500	RADIATOR	1	1						
44	2	124450-44590	CAP, RADIATOR	1	1						
45	1	124450-44510	TANK ASSY, SUB	1	1						
47	2	124450-44530	CAP	1	1						
48	2	124450-44560	RETAINER	1	1						
49	2	23061-070230	PIPE, 7X 230	1	1						
50	1	121470-44540	LABEL, SUB-TANK	1	1						
51	1	124450-44550	BAND	1	1						
52	1	129111-44590	PROTECTOR	1	1						
53	1	121256-44600	BRACKET, SUB TANK	1	1						
54	1	171301-49010	PIPE, WATER	1	1						
55	1	171301-49020	PIPE, WATER	1	1						
56	1	23010-038000	CLAMP, 38	4	4						
57	1	26014-080202	BOLT, M8X 20	4	4						
58	1	26366-080002	NUT, M8	4	4						

Remarks
(G) THESE PARTS ARE SOLD BY FIG.19,
REF.NO.1,2.

Fig.11. FUEL INJECTION PUMP

(A)=3TNE84-AGD
(B)=3TNE88-AGD
(C)=4TNE88-AGD

(D)=4TNE84T-AGD
(E)=
(F)=

Y00B5190
3. 4TNE84, 88 (T) -AGD

1 1 FO7ンシャポンプ
FUEL INJECTION PUMP

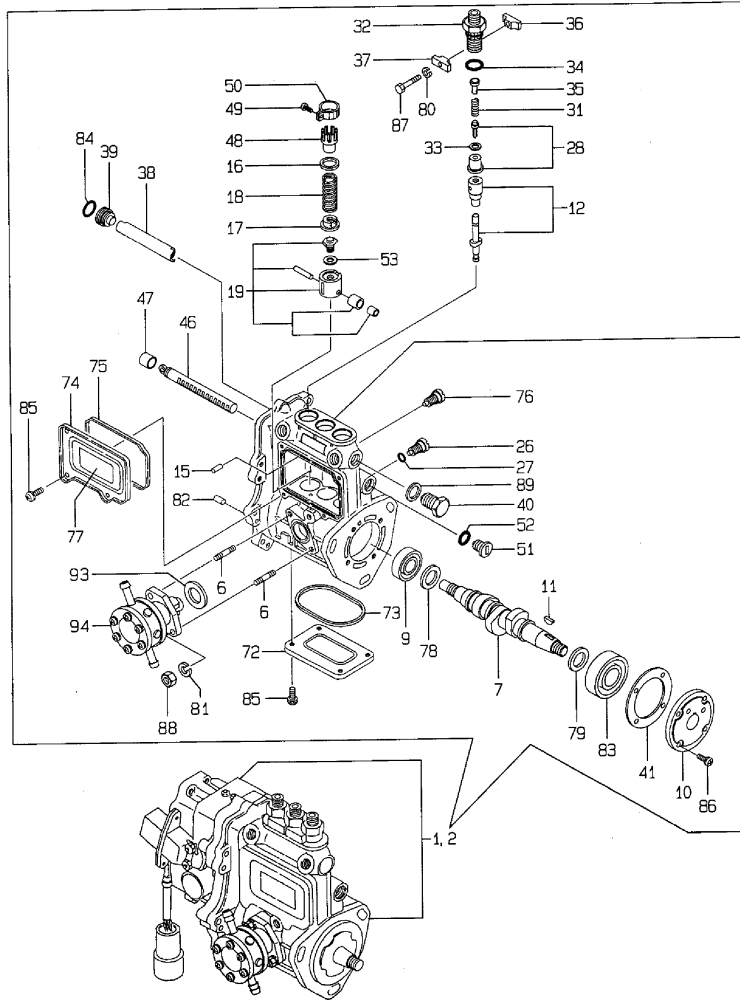

No.	Lev.	Parts No.	Description	Q'ty						I	R
				(A)	(B)	(C)	(D)	(E)	(F)		
1	1	729212-51200	PUMP ASSY, INJECTION	1							1
2	1	729212-51210	PUMP ASSY, INJECTION		1						1
6	2	129155-51020	STUD	2	2						
7	2	119810-51040	CAMSHAFT	1	1						
9	2	129155-51050	BEARING, 17BM001D	1	1						
10	2	129155-51060	SUPPORT, CAMSHAFT	1	1						
11	2	122710-51090	KEY	1	1						
12	2	129506-51100	PLUNGER ASSY	3	3						
15	2	129155-51140	PIN	3	3						
16	2	174307-51170	RETAINER, SPRING A	3	3						
17	2	129155-51180	RETAINER, SPRING	3	3						
18	2	124950-51190	SPRING, PLUNGER	3	3						
19	2	129155-51200	TAPPET ASSY	3	3						
26	2	129155-51270	STOPPER, TAPPET	3	3						
27	2	129155-51280	O-RING, S6	3	3						
28	2	129100-51300	VALVE ASSY, DELIVERY	3	3						
31	2	129155-51320	SPRING, DELIVERY	3	3						
32	2	129155-51340	RETAINER	3	3						
33	2	124550-51350	GASKET, DELIVERY	3	3						
34	2	124550-51370	O-RING	3	3						
35	2	129155-51370	STOPPER, VALVE	3	3						
36	2	129155-51380	STOPPER	2	2						
37	2	129155-51390	STOPPER	2	2						
38	2	129155-51400	DEFLECTOR	1	1						
39	2	129155-51410	BOLT	1	1						
40	2	129155-51420	PLUG, M16	1	1						
41	2	129155-51450	SHIM SET, ADJUSTING	1	1						
46	2	129155-51500	RACK, CONTROL	1	1						
47	2	129155-51521	BUSH, RACK	1	1						
48	2	129155-51550	PINION, CONTROL	3	3						
49	2	122117-51560	SCREW	3	3						
50	2	174307-51560	PINION	3	3						
51	2	129155-51570	PLUG, M12	1	1						
52	2	129155-51580	O-RING	1	1						
53	2	129155-51600	SHIM SET, ADJUSTING	3	3						
72	2	129155-51700	COVER	1	1						
73	2	129155-51710	GASKET	1	1						
74	2	129155-51750	COVER	1	1						
75	2	129155-51760	GASKET	1	1						
76	2	129155-51790	STOOPER, RACK	1	1						
77	2	129156-51910	LABEL, CAUTION	1	1						
78	2	129155-51930	SPACER, T=3.25	1	1						
79	2	129155-51940	SPACER, T=1.5	1	1						
80	2	22217-050000	WASHER, SPRING 5	2	2						
81	2	22217-060000	WASHER, SPRING 6	2	2						
82	2	22351-050010	PIN, SPRING 5.0X10	2	2						
83	2	24101-063034	BEARING, BALL 6303	1	1						
84	2	24341-000160	O-RING, 1AS16.0	1	1						
85	2	26022-050102	SCREW, M5X10	8	8						
86	2	26022-060162	SCREW, M6X16	4	4						
87	2	26116-050302	BOLT, M5X 30 PLATED	2	2						

Remarks

(1) GOVERNOR ASSY(FIG.12) IS INCORPORATED IN THIS FOP.CMP (REF.NO.1,2).
(G) THESE PARTS ARE SOLD BY FIG.19, REF.NO.1,2.

Fig.11. FUEL INJECTION PUMP

(A)=3TNE84-AGD
(B)=3TNE88-AGD
(C)=4TNE88-AGD

(D)=4TNE84T-AGD
(E)=
(F)=

Y0085190
3. 4TNE84, 88 (T) -AGD

1.1 FO7ンシャポンプ
FUEL INJECTION PUMP

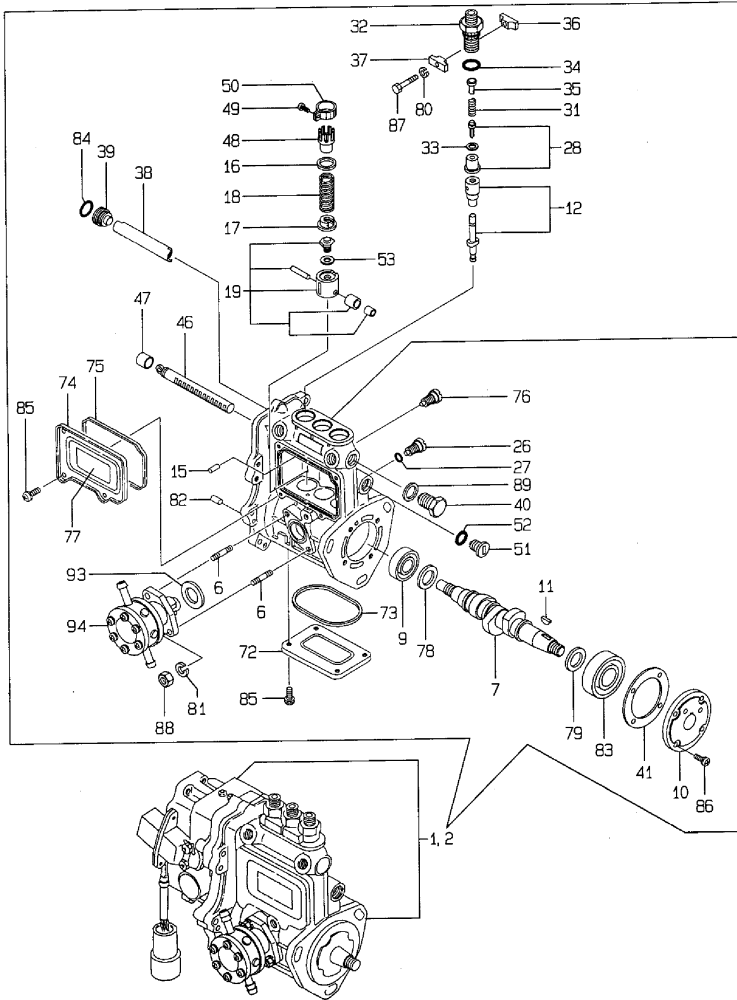

No.	Lev.	Parts No.	Description	Q'ty						I	R
				(A)	(B)	(C)	(D)	(E)	(F)		
88	2	26716-060002	NUT, M6	2	2						
89	2	22190-160002	WASHER, SEAL 16	1	1						
93	2	129155-52050	GASKET	1	1						G
94	2	129100-52100	PUMP ASSY, FUEL FEED	1	1						

Remarks

- (1) GOVERNOR ASSY(FIG.12) IS INCORPORATED IN THIS FOP.CMP (REF.NO.1,2).
- (G) THESE PARTS ARE SOLD BY FIG.19, REF.NO.1,2.

Fig.12. GOVERNOR

(A)=3TNE84-AGD
(B)=3TNE88-AGD
(C)=4TNE88-AGD

(D)=4TNE84T-AGD
(E)=
(F)=

Y0085190
3, 4TNE84, 88 (T) -AGD

12 加減
GOVERNOR

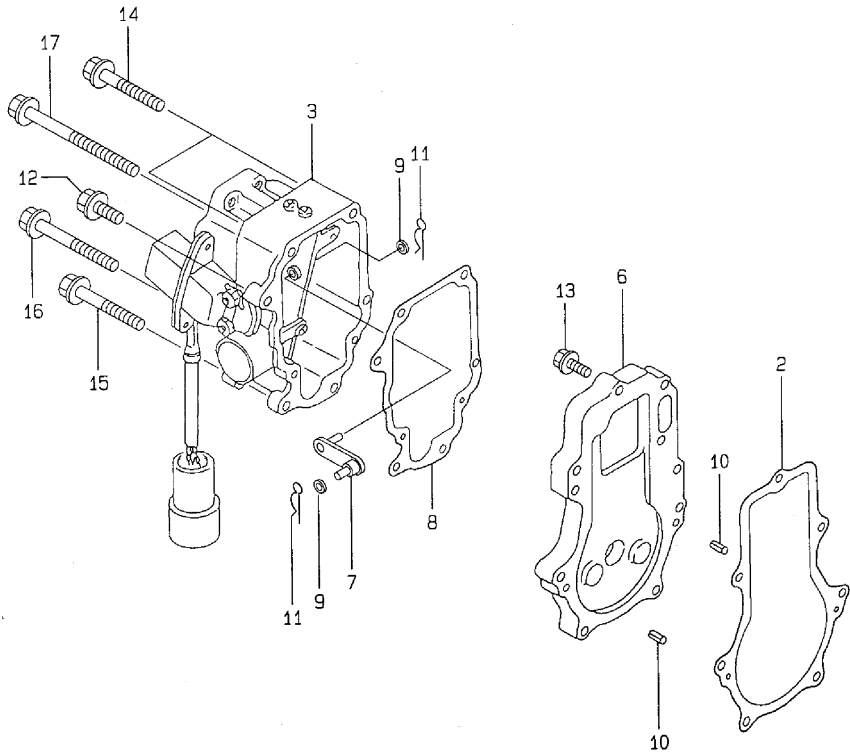

No.	Lev.	Parts No.	Description	Qty						I	R
				(A)	(B)	(C)	(D)	(E)	(F)		
2	2	129116-61051	GASKET	1	1						
3	2	119649-61100	ACTUATOR	1	1						
6	2	129116-61110	SPACER	1	1						
7	2	129116-61120	LINK	1	1						
8	2	119649-61151	GASKET	1	1						
9	2	22117-040000	WASHER, 4	2	2						
10	2	22351-040010	PIN, SPRING 4.0X10	2	2						
11	2	22360-050000	SNAP PIN 5	2	2						
12	2	26106-060202	BOLT, M6X 20 PLATED	1	1						
13	2	26106-060222	BOLT, M6X 22 PLATED	7	7						
14	2	26106-060452	BOLT, M6X 45 PLATED	2	2						
15	2	26106-060602	BOLT, M6X 60 PLATED	1	1						
16	2	26106-060702	BOLT, M6X 70 PLATED	1	1						
17	2	26106-060852	BOLT, M6X 85 PLATED	1	1						

Fig.13. FUEL INJECTION VALVE

(A)=3TNE84-AGD
(B)=3TNE88-AGD
(C)=4TNE88-AGD

(D)=4TNE84T-AGD
(E)=
(F)=

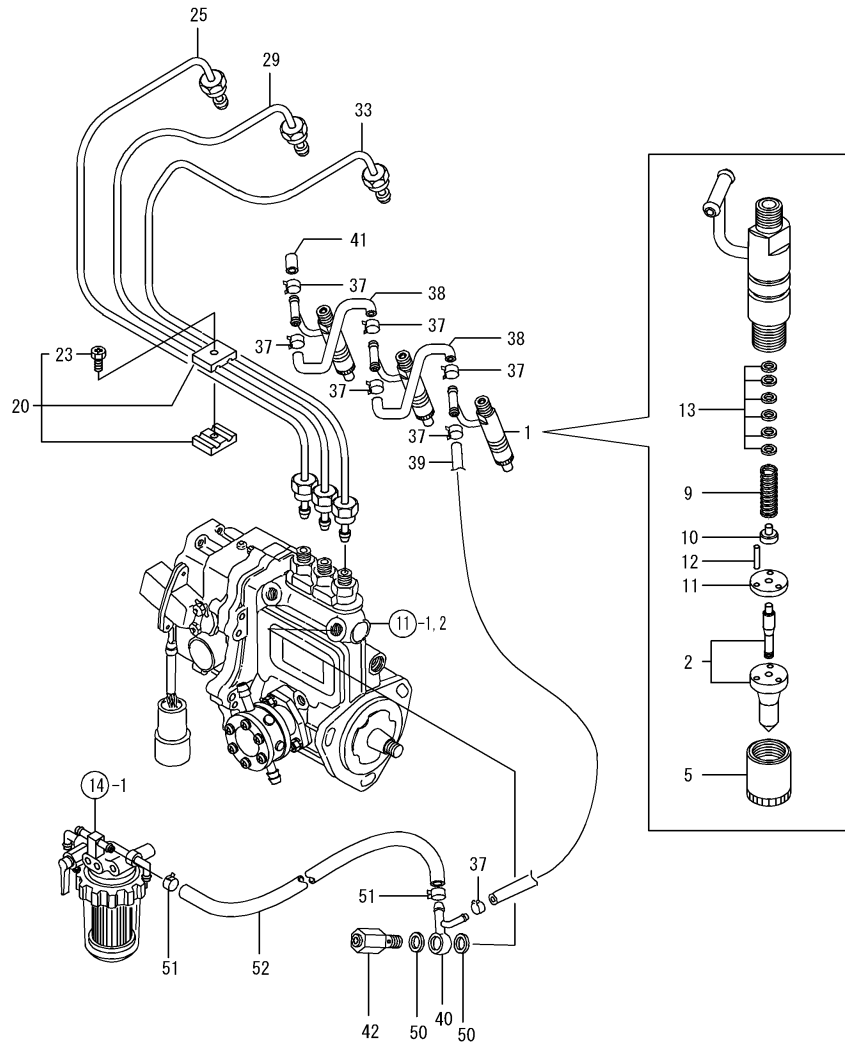

No.	Lev.	Parts No.	Description	Q'ty						I	R
				(A)	(B)	(C)	(D)	(E)	(F)		
1	1	719810-53100	VALVE ASSY,INJECTION	3	3						
2	2	119810-53000	VALVE ASSY,INJECTION	3	3						
5	2	114250-53080	NUT, NOZZLE D16.95	3	3						
9	2	114250-53120	SPRING, NOZZLE	3	3						
10	2	114250-53130	SEAT, SPRING	3	3						
11	2	114250-53140	PLATE	3	3						
12	2	114250-53210	PIN	6	6						
13	2	114250-53400	SHIM SET	3	3						
20	1	119305-59120	RETAINER, PIPE	2	2						
23	2	129150-59131	BOLT, M4X14	2	2						
25	1	129002-59810	PIPE ASSY, INJECTION	1	1						
29	1	129002-59820	PIPE ASSY, INJECTION	1	1						
33	1	129002-59830	PIPE ASSY, INJECTION	1	1						
37	1	124066-59100	CLIP, HOSE 8	7	7						
38	1	121250-59550	PIPE, FUEL D8X120	2	2						
39	1	119840-59560	PIPE, FUEL RETURN	1	1						
40	1	119840-59570	JOINT	1	1						
41	1	129150-59580	CAP	1	1						
42	1	129100-59951	VALVE ASSY, CHECK	1	1						
50	1	23414-120000	GASKET, 12X1.0	2	2						G
51	1	124766-59050	CLIP, HOSE 12	2	2						
52	1	129255-59580	PIPE, FUEL	1	1						

Remarks
(G) THESE PARTS ARE SOLD BY FIG.19,
REF.NO.1,2.

Fig.14. FUEL LINE

(A)=3TNE84-AGD
(B)=3TNE88-AGD
(C)=4TNE88-AGD

(D)=4TNE84T-AGD
(E)=
(F)=

Y00B5190
3, 4TNE84, 88 (T) -AGD

14 F0117
FUEL LINE

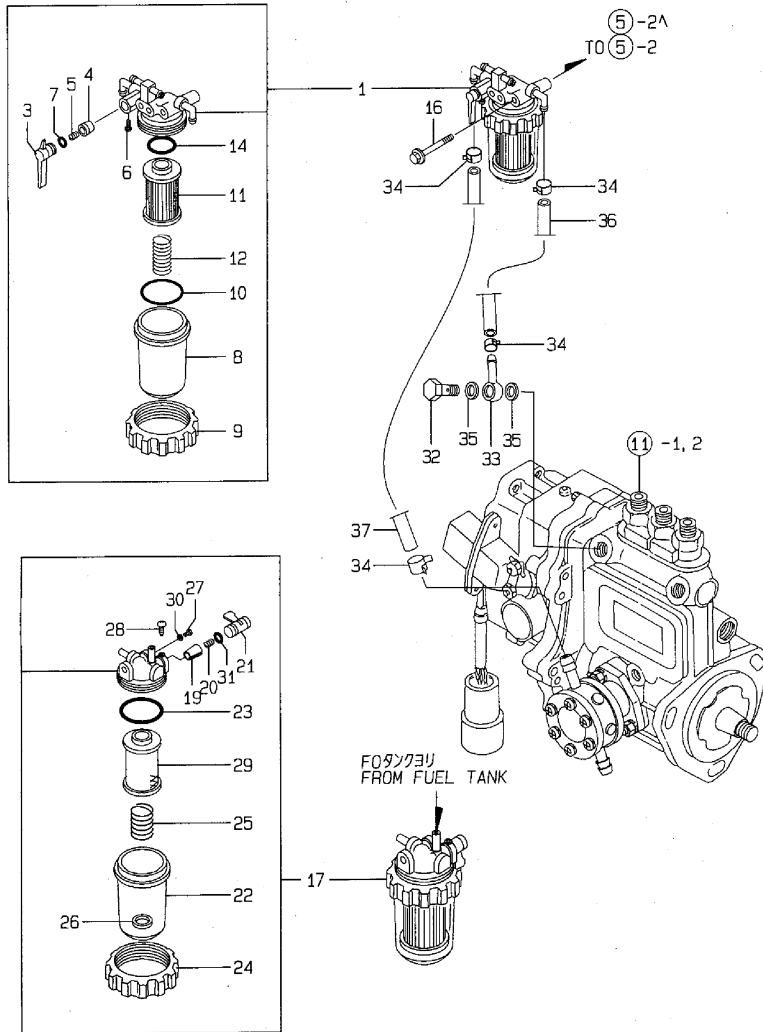

No.	Lev.	Parts No.	Description	Q'ty						I	R
				(A)	(B)	(C)	(D)	(E)	(F)		
1	1	129052-55620	FILTER ASSY, FUEL	1	1						
3	2	129100-55670	LEVER	1	1						
4	2	104200-55321	VALVE, TAPER	1	1						
5	2	104200-55330	SPRING, VALVE	1	1						
6	2	104200-55750	SCREW, M4	1	1						
7	2	24311-240100	O-RING, 1AP10A	1	1						
8	2	129100-55680	CUP, STRAINER	1	1						
9	2	129100-55690	RING, RETAINING	1	1						
10	2	24321-000650	O-RING, 1AG65.0	1	1						G
11	2	129100-55650	ELEMENT	1	1						
12	2	129100-55700	SPRING	1	1						
14	2	24311-000160	O-RING, 1AP16.0	1	1						
16	1	26014-080702	BOLT, M8X 70	1	1						
17	1	121257-55700	SEPARATOR, WATER	1	1						
19	2	104200-55321	VALVE, TAPER	1	1						
20	2	104200-55330	SPRING, VALVE	1	1						
21	2	104200-55341	HANDLE	1	1						
22	2	121254-55510	COVER	1	1						
23	2	102103-55520	O-RING	1	1						
24	2	110250-55610	RING, RETAINING	1	1						
25	2	121257-55720	SPRING	1	1						
26	2	121257-55731	FLOAT	1	1						
27	2	101720-55750	PLUG, 6	2	2						
28	2	104200-55750	SCREW, M4	1	1						
29	2	171081-55910	SCREEN	1	1						
30	2	23418-060000	GASKET, 6X1.0	2	2						
31	2	24311-240100	O-RING, 1AP10A	1	1						
32	1	103854-39140	BOLT, PIPE JOINT	1	1						
33	1	101304-59020	JOINT, PIPE 12	1	1						
34	1	124766-59050	CLIP, HOSE 12	4	4						
35	1	104200-59170	GASKET, 12	2	2						G
36	1	129555-59510	PIPE, D13/7.5X180	1	1						
37	1	105025-59530	PIPE, FUEL D13X400	1	1						

Remarks
(G) THESE PARTS ARE SOLD BY FIG.19,
REF.NO.1,2.

Fig.15. STARTING MOTOR

(A)=3TNE84-AGD
(B)=3TNE88-AGD
(C)=4TNE88-AGD

(D)=4TNE84T-AGD
(E)=
(F)=

Y0085190
3, 4TNE84, 88 (T) -AGD

15 スターティングモータ
STARTING MOTOR

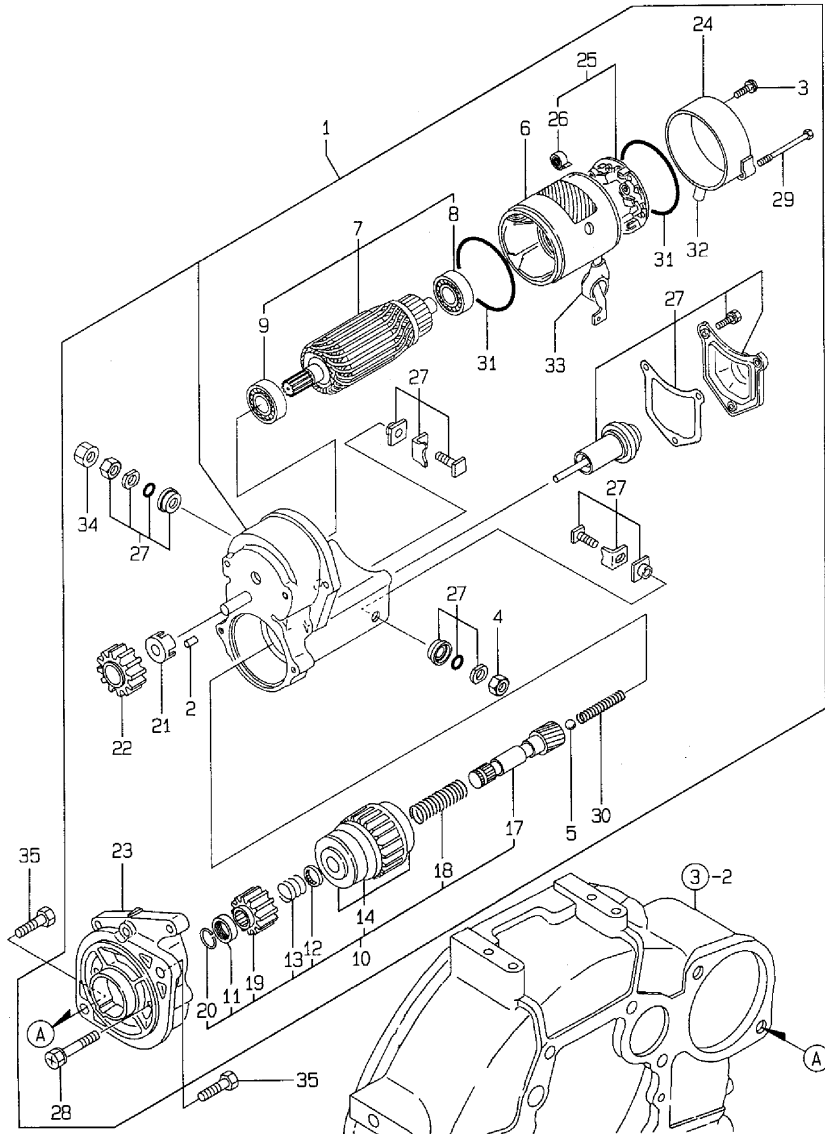

No.	Lev.	Parts No.	Description	Q'ty						I	R
				(A)	(B)	(C)	(D)	(E)	(F)		
1	1	129129-77010	STARTER ASSY	1	1						
2	2	X0283060061	ROLLER	5	5						
3	2	X0289030010	SCREW	2	2						
4	2	X9490561370	NUT	1	1						
5	2	X9491200240	BALL	1	1						
6	2	129129-77210	YOKE ASSY	1	1						
7	2	129129-77220	ARMATURE ASSY	1	1						
8	3	129129-77230	BEARING	1	1						
9	3	129129-77240	BEARING	1	1						
10	2	129129-77250	STARTER	1	1						
11	3	X0280210230	NUT	1	1						
12	3	X0283270140	RETAINER	1	1						
13	3	X9491703371	SPRING, COIL	1	1						
14	3	129129-77390	CLUTCH ASSY	1	1						
17	3	129129-77400	SHAFT	1	1						
18	3	129129-77410	SPRING, COIL	1	1						
19	3	129129-77420	PINION, STARTER	1	1						
20	3	129129-77430	RING	1	1						
21	2	129129-77260	RETAINER	1	1						
22	2	129129-77270	PINION	1	1						
23	2	129129-77280	HOUSING	1	1						
24	2	129129-77290	FRAME	1	1						
25	2	129129-77300	HOLDER ASSY	1	1						
26	3	X9491730461	SPRING	4	4						
27	2	129129-77310	SWITCH ASSY	1	1						
28	2	129129-77320	BOLT	2	2						
29	2	129129-77330	BOLT	2	2						
30	2	129129-77340	SPRING	1	1						
31	2	129129-77350	O-RING	2	2						
32	2	129129-77361	BUSH	1	1						
33	2	129129-77380	CAP	1	1						
34	2	129129-77370	NUT	1	1						
35	1	26116-120252	BOLT, M12X 25 PLATED	2	2						

Fig.16. GENERATOR

(A)=3TNE84-AGD
(B)=3TNE88-AGD
(C)=4TNE88-AGD

(D)=4TNE84T-AGD
(E)=
(F)=

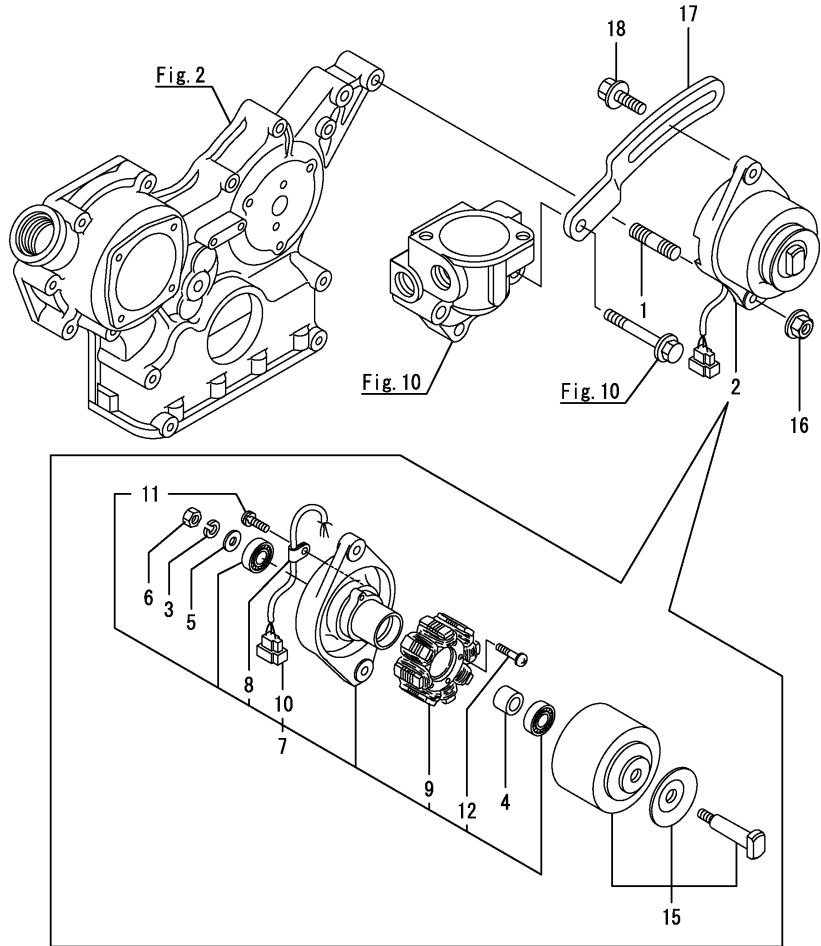

No.	Lev.	Parts No.	Description	Q'ty						I	R
				(A)	(B)	(C)	(D)	(E)	(F)		
1	1	121450-01570	BOLT, STUD	1	1						
2	1	129150-77202	GENERATOR	1	1						
2-1	1	129150-77203	DINAMO ASSY	1	1						N
		(A=EXXXXX) (B=EXXXXX)									
3	2	XM219230000	WASHER, SPRING	1	1						
4	2	XM329830000	COLLAR	1	1						
5	2	XM860250000	WASHER, 10	1	1						
6	2	XM863720000	NUT	1	1						
7	2	129150-77210	PLATE ASSY	1	1						
8	3	XM069000000	CLAMP	1	1						
9	3	XM081780000	STATOR	1	1						
10	3	XM178780000	COUPLER	1	1						
11	3	XYSPS400800	SCREW	1	1						
12	3	XYSPS402400	SCREW	2	2						
15	2	129150-77230	FLYWHEEL ASSY	1	1						
15-1	2	129150-77280	FLYWHEEL ASSY	1	1						N
		(A=EXXXXX) (B=EXXXXX)									
16	1	26366-100002	NUT, M10	1	1						
17	1	129410-77330	ADJUSTER, BELT	1	1						
18	1	26014-080252	BOLT, M8X 25	1	1						

Fig.17. PULSER

(A)=3TNE84-AGD
(B)=3TNE88-AGD
(C)=4TNE88-AGD

(D)=4TNE84T-AGD
(E)=
(F)=

Y0085190
3, 4TNE84, 88 (T) -AGD

17 パルサー
PULSER

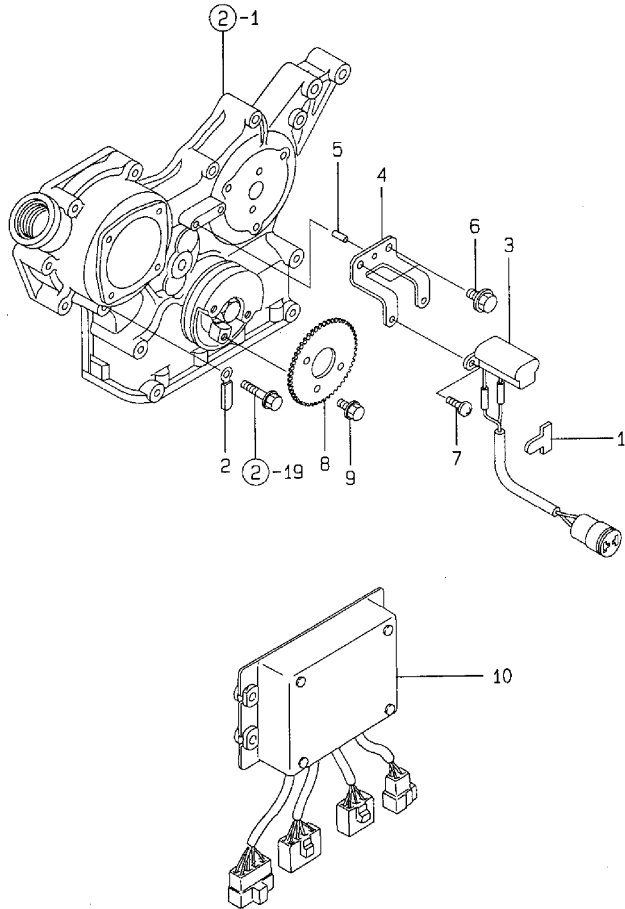

No.	Lev.	Parts No.	Description	Q'ty						I	R
				(A)	(B)	(C)	(D)	(E)	(F)		
1	1	172010-08160	STICKER, WIRE	1	1						
2	1	194180-51640	CLAMP, HARNESS	1	1						
3	1	119649-78500	PULSAR	1	1						
4	1	129116-78510	BRACKET, PULSAR	1	1						
5	1	22351-040010	PIN, SPRING 4.0X10	1	1						
6	1	26116-060122	BOLT, M6X 12 PLATED	2	2						
7	1	26557-040082	SCREW, M4X 8	2	2						
8	1	119649-78650	GEAR, PULSAR	1	1						
9	1	26106-100142	BOLT, M10X 14 PLATED	3	3						
10	1	129111-78802	CONTROLLER, MAIN 4P	1	1						

Fig.18. ELECTRIC PARTS

(A)=3TNE84-AGD
(B)=3TNE88-AGD
(C)=4TNE88-AGD

(D)=4TNE84T-AGD
(E)=
(F)=

Y00B5190
3, 4TNE84, 88 (T) -AGD

18 デンソクピン
ELECTRIC PARTS

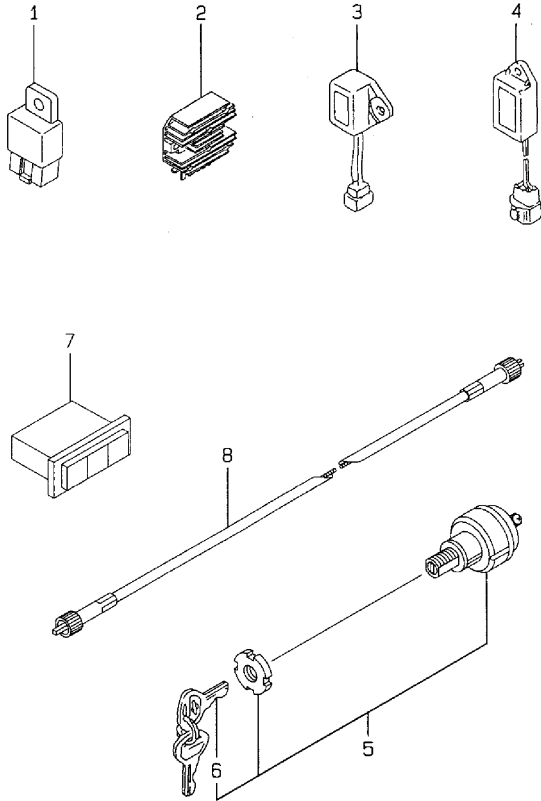

No.	Lev.	Parts No.	Description	Q'ty						I	R
				(A)	(B)	(C)	(D)	(E)	(F)		
1	1	119247-77100	RELAY, SAFETY	1	1						
2	1	119640-77711	LIMITER, CURRENT	1	1						
3	1	121522-77721	INDICATOR	1	1						
4	1	128300-77920	TIMER	1	1						
5	1	121400-91251	SWITCH, STARTER	1	1						
6	2	121400-91271	KEY, SWITCH	1	1						
7	1	129411-91310	LAMP	1	1						
7A	2	129411-91360	BULB, 12V-3.4W	6	6						W
8	1	194185-56900	CABLE ASSY, METER	1	1						

Fig.19. GASKET SET(OPTIONAL) & TOOL

(A)=3TNE84-AGD
(B)=3TNE88-AGD
(C)=4TNE88-AGD

(D)=4TNE84T-AGD
(E)=
(F)=

Y00B5190
3, 4TNE84, 88 (T) -AGD

19 パッキンセット (オプション) & ツウグ
GASKET SET (OPTIONAL) & TOOL

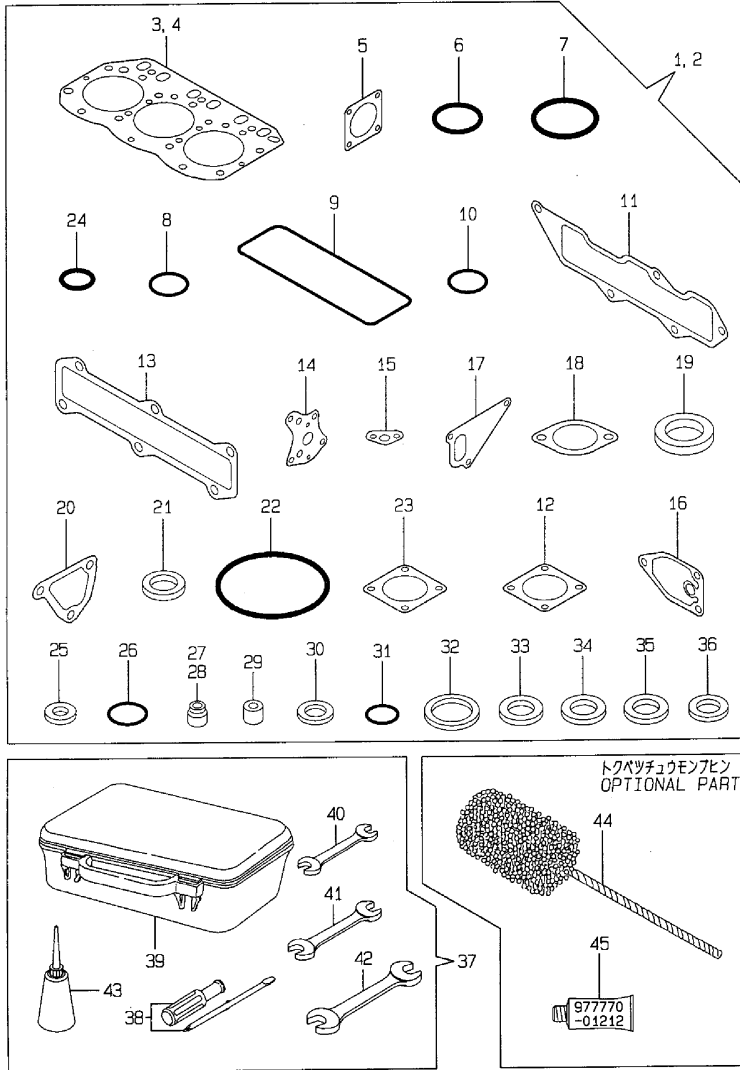

No.	Lev.	Parts No.	Description	Q'ty						I	R
				(A)	(B)	(C)	(D)	(E)	(F)		
1	1	729212-92600	GASKET SET	1							1
2	1	729212-92610	GASKET SET		1						1
3	2	129002-01331	GASKET, HEAD	1							
4	2	129001-01340	GASKET, HEAD		1						
5	2	124240-01883	GASKET	1	1						
6	2	121850-51960	O-RING	1	1						
7	2	24311-000320	O-RING, 1AP32.0	1	1						
8	2	24311-000320	O-RING, 1AP32.0	1	1						
9	2	129001-11310	GASKET, BONNET	1	1						
10	2	24311-000120	O-RING, 1AP12.0	3	3						
11	2	129001-12110	GASKET, MANIFOLD	1	1						
12	2	124701-11911	GASKET, SILENCER	1	1						
13	2	129001-13110	GASKET	1	1						
14	2	129150-32020	GASKET, PUMP	1	1						
15	2	129150-35041	GASKET	1	1						
16	2	129150-35111	GASKET	1	1						
17	2	129100-42020	GASKET, WATER PUMP	1	1						
18	2	129795-49551	GASKET	1	1						
19	2	129150-49811	GASKET, THERMOSTAT	1	1						
20	2	129100-49840	GASKET	1	1						
21	2	124465-44950	GASKET, 16	2	2						
22	2	24321-000650	O-RING, 1AG65.0	1	1						
23	2	129150-77511	GASKET	1	1						
24	2	24311-000160	O-RING, 1AP16.0	2	2						
25	2	22190-080002	WASHER, SEAL 6	5	5						
26	2	24341-000240	O-RING, 1AS24.0	1	1						
27	2	121400-11340	SEAL, VALVE STEM	3	3						
28	2	124460-11340	SEAL, VALVE STEM	3	3						
29	2	119625-11871	PROTECTOR, NOZZLE	3	3						
30	2	119625-11880	SEAT, NOZZLE	3	3						
31	2	24311-000160	O-RING, 1AP16.0	1	1						
32	2	23414-080000	GASKET, 8X1.0	2	2						
33	2	23414-100000	GASKET, 10X1.0	2	2						
34	2	129155-52050	GASKET	1	1						
35	2	23414-120000	GASKET, 12X1.0	2	2						
36	2	104200-59170	GASKET, 12	2	2						
37	1	171001-93100	BOX, TOOL	1	1						
38	2	104200-92350	DRIVER, SCREW	1	1						
39	2	104200-92600	BOX, TOOL	1	1						
40	2	28110-100120	SPANNER, 10X12	1	1						
41	2	28110-140170	SPANNER, 14X17	1	1						
42	2	28110-190220	SPANNER, 19X22	1	1						
43	2	28210-000140	OILER	1	1						
44	1	129400-92420	HONE	1	1						1
45	1	977770-01212	GASKET, LIQUID	1	1						1

Remarks
(1) OPTIONAL PART.

Fig.20. CYLINDER BLOCK

(A)=3TNE84-AGD
(B)=3TNE88-AGD
(C)=4TNE88-AGD

(D)=4TNE84T-AGD
(E)=
(F)=

Y00B5190
3, 4TNE84, 88 (T) -AGD

20 シリンダブロック
CYLINDER BLOCK

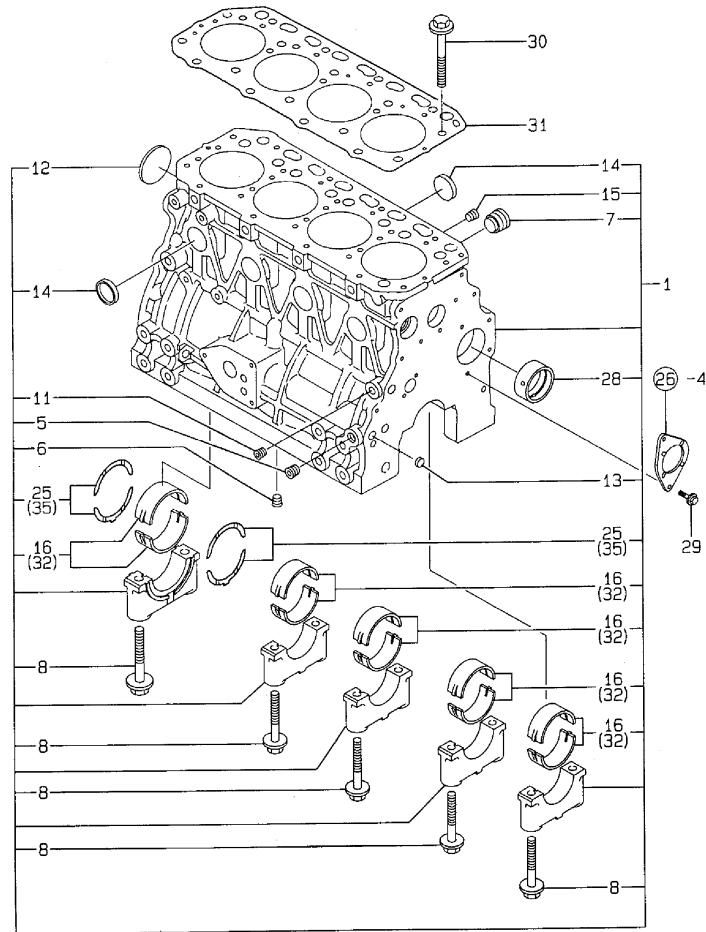

No.	Lev.	Parts No.	Description	Qty						I	R	
				(A)	(B)	(C)	(D)	(E)	(F)			
1	1	729407-01561	BLOCK ASSY, CYLINDER			1						
5	2	124160-01910	PLUG, PT1/4			2						
6	2	124160-01910	PLUG, PT1/4			1						
7	2	171051-01921	PLUG, NPTF1			1						
8	2	129150-02020	BOLT, METAL CAP			10						
11	2	23871-010000	PLUG, R01			1						
12	2	27231-500000	PLUG 50			1						
13	2	27241-120000	PLUG, 12			2						
14	2	27241-300000	PLUG 30			8						
15	2	23871-030000	PLUG, R03			1						
16	2	129001-02800	BEARING, MAIN			5						
25	2	129150-02930	BEARING, THRUST			2						
28	2	129795-02411	BUSH, CAMSHAFT			1						
29	1	26106-080162	BOLT, M8X 16 PLATED			2						
30	1	129150-01200	BOLT, HEAD			18						
31	1	129407-01340	GASKET, HEAD			1						G
32	1	129150-02870	BEARING, 0.25 US			5						1
35	1	129150-02940	BEARING, THRUST 0.25			2						2

Remarks

- (1) UNDER-SIZED(U.S=0.25)PART.
- (2) OVER-SIZED(O.S=0.25)PART.
- (G) THESE PARTS ARE SOLD BY FIG.38,REF.NO.1.

Fig.21. GEAR HOUSING

(A)=3TNE84-AGD
(B)=3TNE88-AGD
(C)=4TNE88-AGD

(D)=4TNE84T-AGD
(E)=
(F)=

Y0085190
3. 4TNE84, 88 (T) -AGD

21 #ギヤケース
GEAR HOUSING

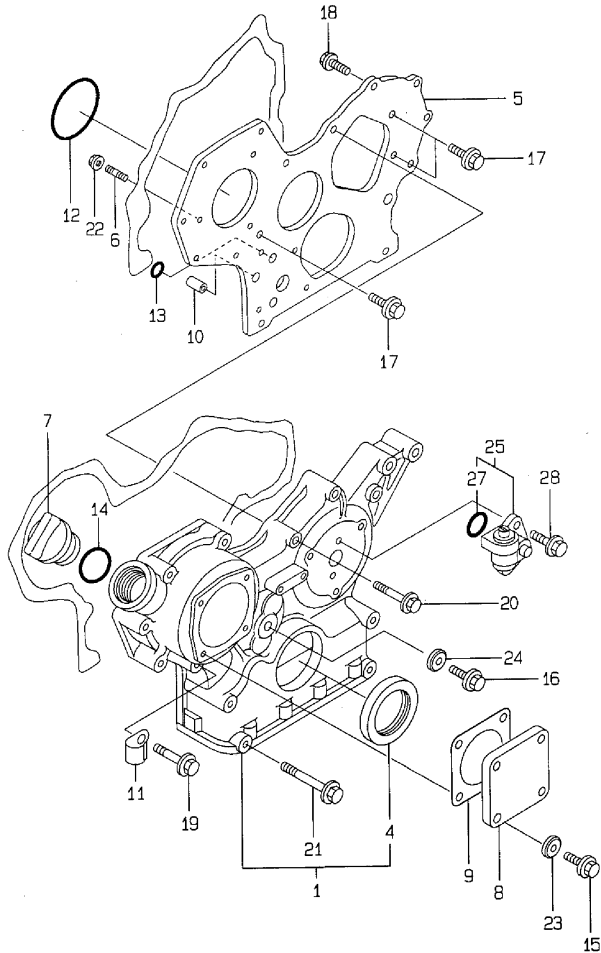

No.	Lev.	Parts No.	Description	Q'ty						I	R
				(A)	(B)	(C)	(D)	(E)	(F)		
1	1	719810-01500	CASE ASSY, GEAR			1					
4	2	129795-01800	SEAL, OIL			1					
5	1	129400-01520	FLANGE, GEAR CASE			1					
6	1	121450-01560	STUD, M8X22			3					
7	1	124160-01751	COVER, FILLER			1					
8	1	124240-01871	COVER			1					
9	1	124240-01883	GASKET			1					G
10	1	129795-01950	PIPE, KNOCK L=18			2					
11	1	129150-03100	RETAINER, PIPE			1					
12	1	121850-51960	O-RING			1					G
13	1	24311-000160	O-RING, 1AP16.0			2					G
14	1	24311-000320	O-RING, 1AP32.0			1					G
15	1	26106-080122	BOLT, M8X 12 PLATED			4					
16	1	26106-080162	BOLT, M8X 16 PLATED			1					
17	1	26106-080162	BOLT, M8X 16 PLATED			3					
18	1	26106-080202	BOLT, M8X 20 PLATED			2					
19	1	26106-080452	BOLT, M8X 45 PLATED			6					
20	1	26106-080552	BOLT, M8X 55 PLATED			3					
21	1	26106-080852	BOLT, M8X 85 PLATED			4					
22	1	26366-080002	NUT, M8			3					
23	1	22190-080002	WASHER, SEAL 6			4					G
24	1	22190-080002	WASHER, SEAL 6			1					G
25	1	129150-91400	GEAR			1					
27	2	24341-000240	O-RING, 1AS24.0			1					G
28	1	26106-060162	BOLT, M6X 16 PLATED			2					

Remarks
(G) THESE PARTS ARE SOLD BY
FIG.38,REF.NO.1.

Fig.22. FLYWHEEL HOUSING & OIL SUMP

(A)=3TNE84-AGD
 (B)=3TNE88-AGD
 (C)=4TNE88-AGD

(D)=4TNE84T-AGD
 (E)=
 (F)=

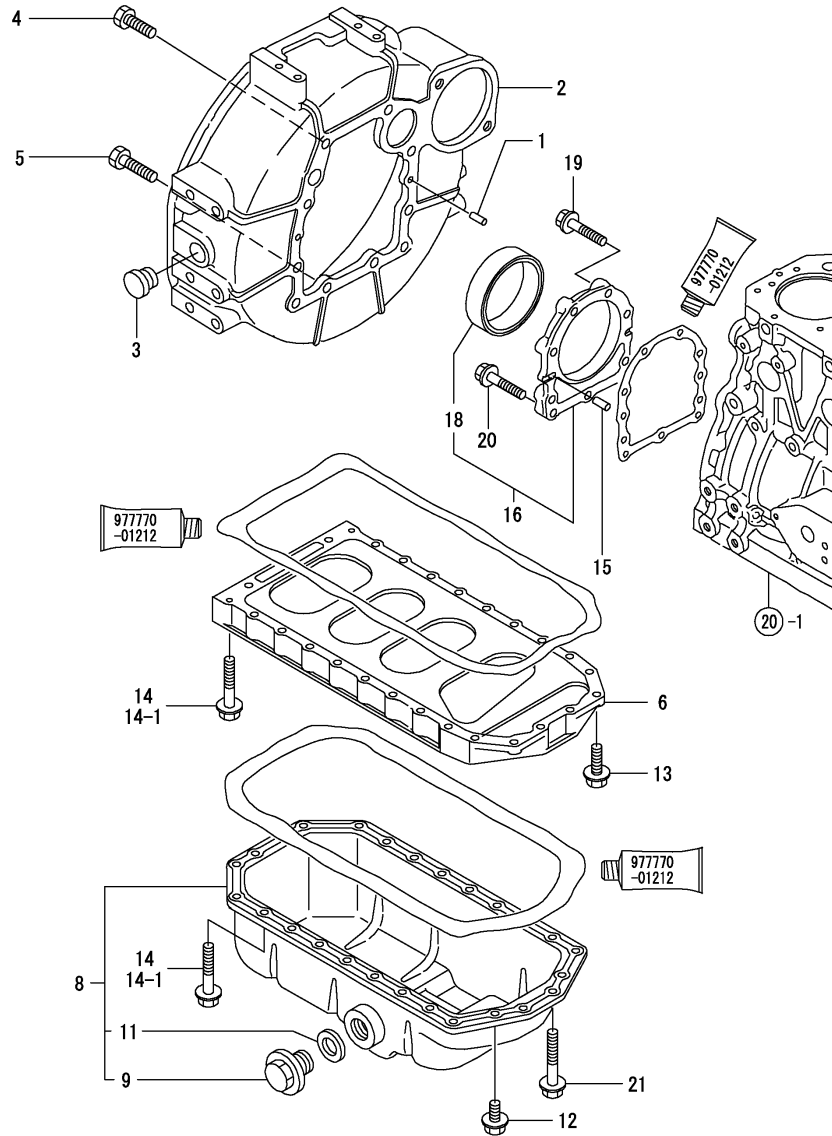

No.	Lev.	Parts No.	Description	Qty						I	R
				(A)	(B)	(C)	(D)	(E)	(F)		
1	1	129100-01580	PIN, M8X16			2					
2	1	171420-01600	HOUSING, FLYWHEEL			1					
3	1	119620-01750	CAP			1					
4	1	26206-100252	BOLT, M10X 25 PLATED			6					
5	1	26206-100302	BOLT, M10X 30 PLATED			4					
6	1	129400-01730	SPACER, OIL SUMP			1					
8	1	129400-01770	SUMP ASSY, OIL			1					
9	2	119640-01640	PLUG, DRAIN M22			1					
11	2	22190-220002	WASHER, SEAL 22			1					
12	1	26106-080162	BOLT, M8X 16 PLATED			4					
13	1	26106-080252	BOLT, M8X 25 PLATED			2					
14	1	26106-080452	BOLT, M8X 45 PLATED			24					
14-1	1	26106-080452	BOLT, M8X 45 PLATED (C=FROM 1ST)			20					K
15	1	129100-01580	PIN, M8X16			2					
16	1	129100-01640	CASE ASSY, OIL SEAL			1					
18	2	129795-01780	SEAL, OIL			1					
19	1	26106-080302	BOLT, M8X 30 PLATED			6					
20	1	26106-080352	BOLT, M8X 35 PLATED			3					
21	1	26106-080502	BOLT, M8X 50 PLATED (C=FROM 1ST)			4					W

Fig.23. CYLINDER HEAD & BONNET

(A)=3TNE84-AGD
(B)=3TNE88-AGD
(C)=4TNE88-AGD

(D)=4TNE84T-AGD
(E)=
(F)=

Y00B5190
3. 4TNE84, 88 (T) -AGD

23 シリンダヘッド & ボンネット
CYLINDER HEAD & BONNET

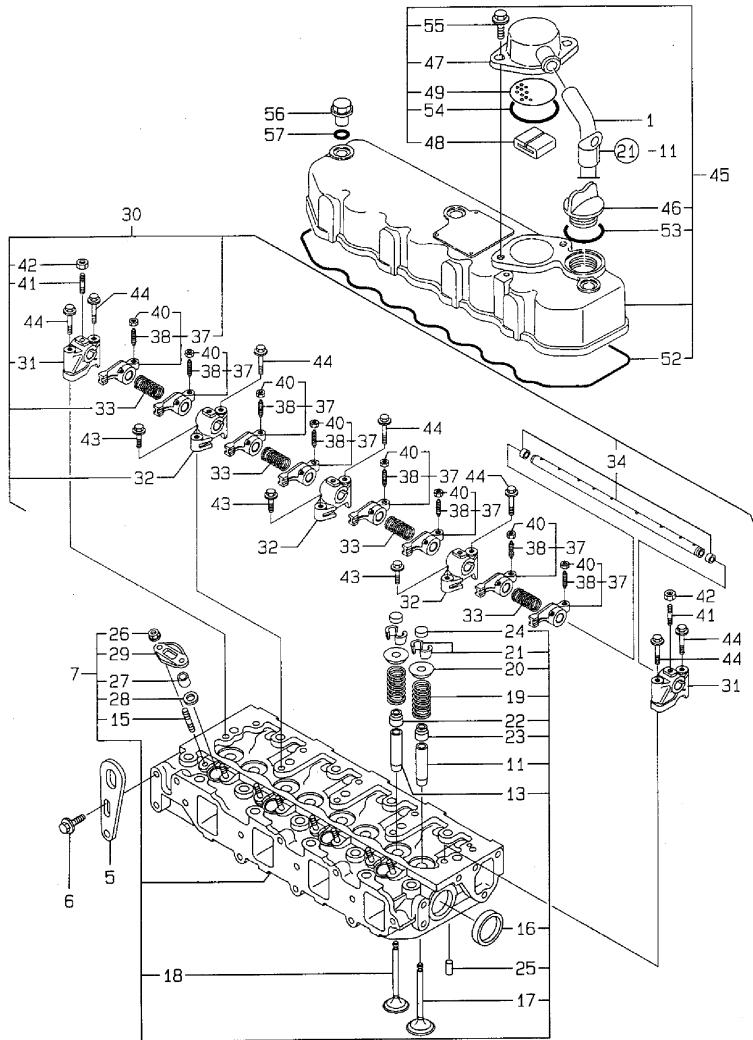

No.	Lev.	Parts No.	Description	Qty						I	R
				(A)	(B)	(C)	(D)	(E)	(F)		
1	1	171350-03090	PIPE , BREATHER 900			1					
5	1	124736-07900	LIFTER			2					
6	1	26106-080142	BOLT, M8X 14 PLATED			4					
7	1	129407-11700	HEAD ASSY, CYLINDER			1					
11	2	120130-11860	GUIDE, VALVE			4					1
13	2	129150-11810	GUIDE, VALVE			4					1
15	2	26216-060202	STUD, M6X 20			8					
16	2	27241-400000	PLUG, 40			2					
17	2	129100-11100	VALVE, INTAKE			4					
18	2	129100-11110	VALVE, EXHAUST			4					
19	2	129795-11120	SPRING, VALVE			8					
20	2	129795-11180	RETAINER, SPRING			8					
21	2	27310-080001	COTTER, 8			8					
22	2	121400-11340	SEAL, VALVE STEM			4					G
23	2	124460-11340	SEAL, VALVE STEM			4					G
24	2	129150-11370	CAP, VALVE			8					
25	2	22351-060012	PIN, SPRING 6.0X12			2					
26	2	26366-060002	NUT, M6			8					
27	2	119625-11871	PROTECTOR, NOZZLE			4					G
28	2	119625-11880	SEAT, NOZZLE			4					G
29	2	119625-11900	RETAINER, NOZZLE			4					
30	1	129500-11240	SHAFT ASSY, ROCKER			1					
31	2	129155-11260	SUPPORT, ROCKER ARM			2					
32	2	129155-11270	SUPPORT, ROCKER ARM			3					
33	2	129150-11280	SPRING			4					
34	2	129550-11290	SHAFT, ROCKER ARM			1					
37	2	129100-11650	ARM, ROCKER			8					
38	3	129150-11230	SCREW, VALVE ADJUST			8					
40	3	129150-11750	NUT, M8			8					
41	2	26226-080182	STUD, M8X 18			3					
42	2	26756-080002	NUT, LOCK M8			3					
43	1	26106-080252	BOLT, M8X 25 PLATED			3					
44	1	26106-080502	BOLT, M8X 50 PLATED			7					
45	1	129400-11350	BONNET ASSY, HEAD			1					
46	2	124160-01751	COVER, FILLER			1					
47	2	129150-03020	COVER, BREATHER			1					
48	2	129150-03070	BAFFLE, BREATHER			1					
49	2	129150-03080	PLATE, BAFFLE			1					
52	2	129550-11310	GASKET, BONNET			1					G
53	2	24311-000320	O-RING, 1AP32.0			1					G
54	2	24341-000500	O-RING, 1AS50.0			1					G
55	2	26106-080162	BOLT, M8X 16 PLATED			2					
56	1	124160-11360	KNOB			3					
57	1	24311-000120	O-RING, 1AP12.0			3					G

Remarks

- (1) REPAIR PART.
- (G) THESE PARTS ARE SOLD BY FIG.38,REF.NO.1.

Fig.24. SUCTION MANIFOLD

(A)=3TNE84-AGD
(B)=3TNE88-AGD
(C)=4TNE88-AGD

(D)=4TNE84T-AGD
(E)=
(F)=

Y00B5190
3, 4TNE84, 8B (T) -AGD

24 キュウキマニホールド
SUCTION MANIFOLD

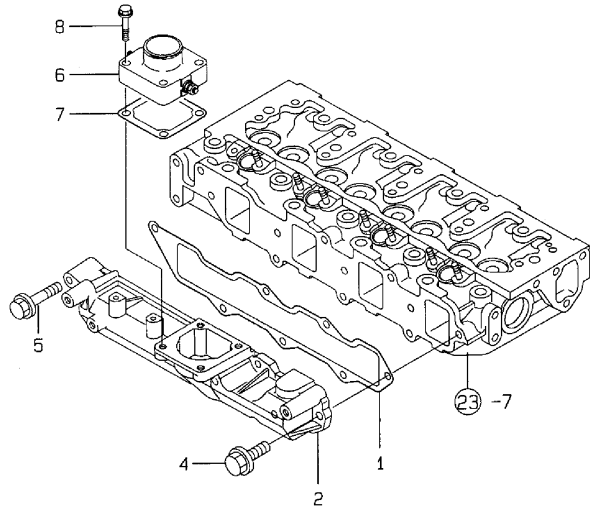

No.	Lev.	Parts No.	Description	Q'ty						I	R
				(A)	(B)	(C)	(D)	(E)	(F)		
1	1	129407-12110	GASKET, MANIFOLD			1					G
2	1	129407-12120	MANIFOLD, AIR INTAKE			1					
4	1	26106-080202	BOLT, M8X 20 PLATED			6					
5	1	26106-080502	BOLT, M8X 50 PLATED			1					
6	1	129120-77501	HEATER			1					
7	1	129150-77511	GASKET			1					G
8	1	26106-080352	BOLT, M8X 35 PLATED			4					

Remarks
(G) THESE PARTS ARE SOLD BY
FIG.38,REF.NO.1.

Fig.25. EXHAUST MANIFOLD

(A)=3TNE84-AGD
(B)=3TNE88-AGD
(C)=4TNE88-AGD

(D)=4TNE84T-AGD
(E)=
(F)=

Y00B5190
3, 4TNE84, 88 (T) -AGD

25 ハイキマニホールド
EXHAUST MANIFOLD

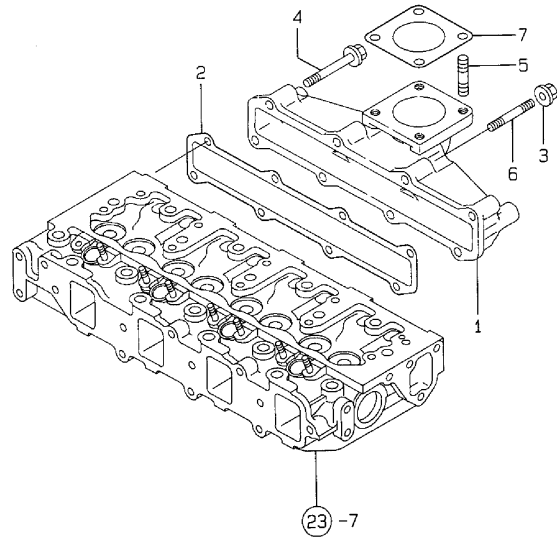

No.	Lev.	Parts No.	Description	Q'ty						I	R
				(A)	(B)	(C)	(D)	(E)	(F)		
1	1	129407-13100	MANIFOLD, EXHAUST			1					
2	1	129407-13110	GASKET			1					G
3	1	194990-22050	NUT, M8			2					
4	1	26106-080402	BOLT, M8X 40 PLATED			6					
5	1	26216-080222	STUD, M8X 22			4					
6	1	26216-080402	STUD, M8X 40			2					
7	1	129400-13201	GASKET, SILENCER			1					G

Remarks
(G) THESE PARTS ARE SOLD BY
FIG.38,REF.NO.1.

Fig.26. CAMSHAFT & DRIVING GEAR

(A)=3TNE84-AGD
(B)=3TNE88-AGD
(C)=4TNE88-AGD

(D)=4TNE84T-AGD
(E)=
(F)=

Y00B5190
3, 4TNE84, 88 (T) -AGD

26 カムシャフト & クドウギヤ
CAMSHAFT & DRIVING GEAR

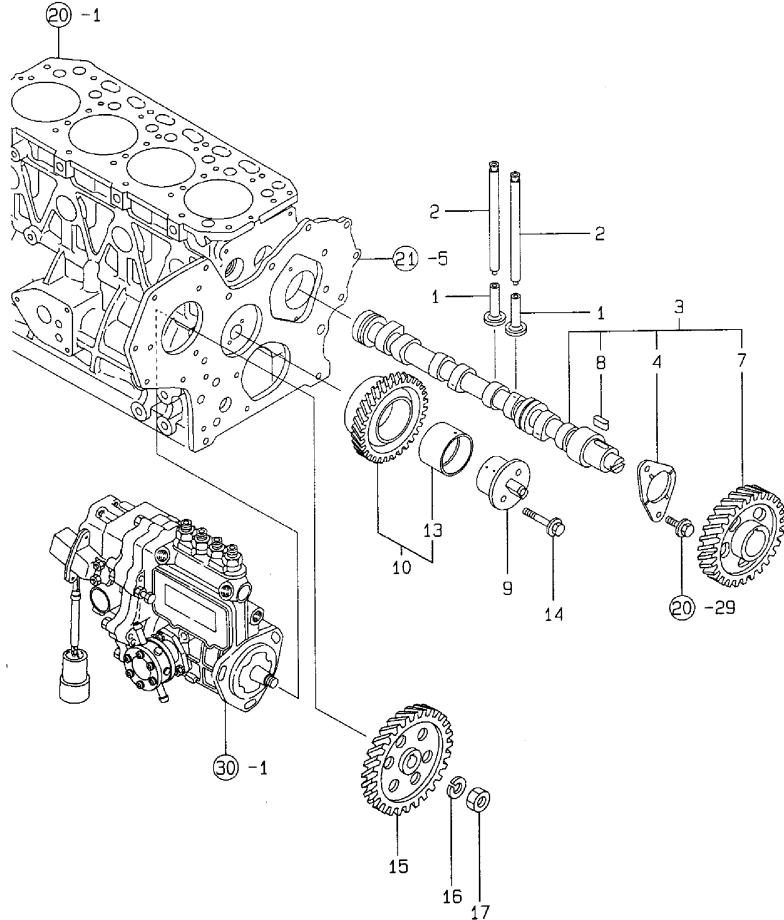

No.	Lev.	Parts No.	Description	Q'ty						I	R
				(A)	(B)	(C)	(D)	(E)	(F)		
1	1	129150-14200	TAPPET			8					
2	1	129150-14400	ROD, PUSH L=178			8					
3	1	729402-14580	CAMSHAFT ASSY			1					
4	2	129150-02450	BEARING, THRUST			1					
7	2	129150-14101	GEAR, CAMSHAFT			1					
8	2	22512-070140	KEY, 7X 14			1					
9	1	129100-25061	SHAFT, IDLE			1					
10	1	129150-25101	GEAR ASSY, IDLE			1					
13	2	129150-25920	BUSH, IDLE GEAR			1					1
14	1	26106-080452	BOLT, M8X 45 PLATED			2					
15	1	129150-25900	GEAR, PUMP			1					
16	1	22217-120000	WASHER, SPRING 12			1					
17	1	26716-120002	NUT, M12			1					

Remarks
(1) REPAIR PART.

Fig.27. CRANKSHAFT & PISTON

(A)=3TNE84-AGD
(B)=3TNE88-AGD
(C)=4TNE88-AGD

(D)=4TNE84T-AGD
(E)=
(F)=

Y00B5190
3, 4TNE84, 88 (T) -AGD

27 クランクシャフト & ピストン
CRANKSHAFT & PISTON

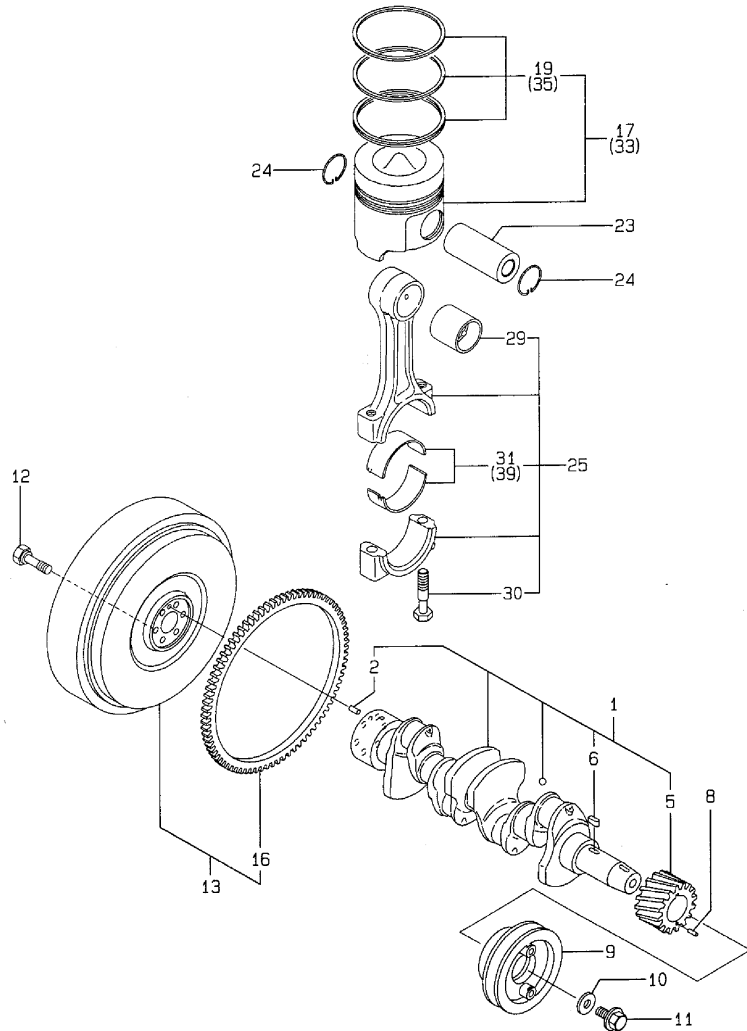

No.	Lev.	Parts No.	Description	Qty						I	R
				(A)	(B)	(C)	(D)	(E)	(F)		
1	1	129407-21000	CRANKSHAFT ASSY			1					
2	2	129100-01580	PIN, M8X16			1					
5	2	129150-21200	GEAR, CRANKSHAFT			1					
6	2	22512-070140	KEY, 7X 14			1					
8	1	22351-040010	PIN, SPRING 4.0X10			1					
9	1	171301-21650	V-PULLEY			1					
10	1	129795-21661	WASHER			1					
11	1	121850-21680	BOLT			1					
12	1	121111-21501	BOLT, FLYWHEEL			6					
13	1	171420-21590	FLYWHEEL ASSY			1					
16	2	124450-21600	GEAR, RING			1					
17	1	129001-22081	PISTON ASSY			4					
19	2	129001-22500	RING SET, PISTON			4					
23	1	129202-22300	PIN, PISTON D26 L70			4					
24	1	22252-000260	RING, 26			8					
25	1	729402-23100	ROD ASSY, CONNECTING			4					
29	2	129100-23910	BEARING, PISTON PIN			4					1
30	2	121550-23200	BOLT, CONNECTING ROD			8					
31	2	129150-23600	BEARING, CRANK PIN			4					
33	1	129001-22901	PISTON ASSY, 0.25 OS			4					2
35	2	129001-22950	RING SET, 0.25 OS			4					2
39	1	129150-23610	BEARING, 0.25 US			4					3

Remarks

- (1) REPAIR PART.
- (2) OVER-SIZE (O.S=0.25) PART.
- (3) UNDER-SIZE(U.S=0.25) PART.

Fig.28. LUB.OIL SYSTEM

(A)=3TNE84-AGD
(B)=3TNE88-AGD
(C)=4TNE88-AGD

(D)=4TNE84T-AGD
(E)=
(F)=

Y0085190
3, 4TNE84, 88 (T) -AGD

28 LUB.OIL SYSTEM

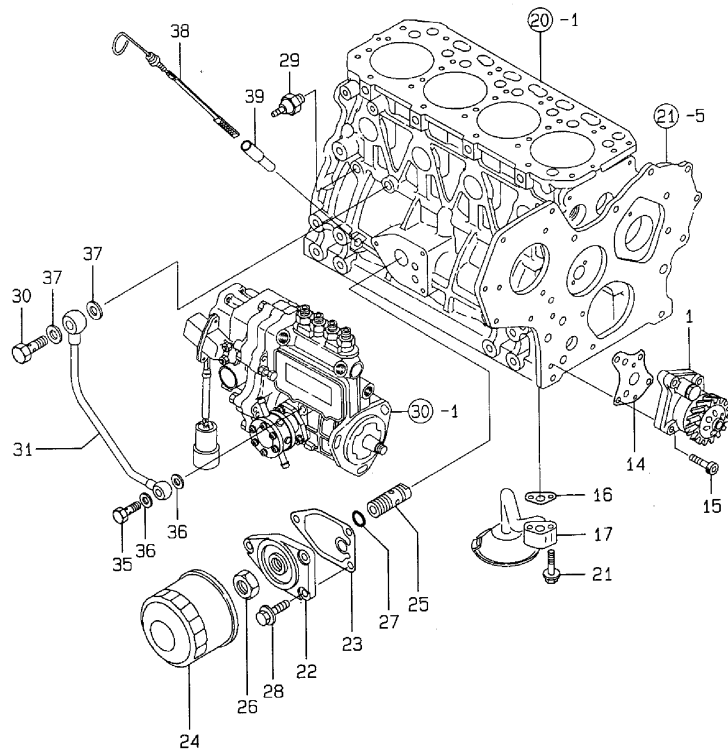

No.	Lev.	Parts No.	Description	Qty						I	R
				(A)	(B)	(C)	(D)	(E)	(F)		
1	1	129407-32000	PUMP ASSY, OIL			1					
14	1	129150-32020	GASKET, PUMP			1					G
15	1	26450-060252	BOLT, M6X 25			4					
16	1	129150-35041	GASKET			1					G
17	1	129436-35090	PIPE ASSY, OIL INLET			1					
21	1	26106-080352	BOLT, M8X 35 PLATED			2					
22	1	129150-35101	BRACKET, STRAINER			1					
23	1	129150-35111	GASKET			1					G
24	1	129150-35151	FILTER, D80XL80			1					
25	1	129001-35300	BOLT, FILTER			1					
26	1	129150-35350	NUT			1					
27	1	24311-000160	O-RING, 1AP16.0			1					G
28	1	26106-080202	BOLT, M8X 20 PLATED			3					
29	1	124160-39450	SWITCH, 0.5KG			1					
30	1	124160-39140	BOLT, PIPE JOINT M10			1					
31	1	129550-39450	PIPE ASSY, OIL			1					
35	1	124550-59820	BOLT, PIPE JOINT M8			1					
36	1	22190-080002	WASHER, SEAL 6			2					G
37	1	23414-100000	GASKET, 10X1.0			2					G
38	1	129136-34800	DIPSTICK, OIL			1					
39	1	121520-34810	GUIDE, DIPSTICK			1					

Remarks
(G) THESE PARTS ARE SOLD BY
FIG.38,REF.NO.1.

Fig.29. COOLING WATER SYSTEM

(A)=3TNE84-AGD
(B)=3TNE88-AGD
(C)=4TNE88-AGD

(D)=4TNE84T-AGD
(E)=
(F)=

Y0085190
3, 4TNE84, 88 (1) -AGD

29 CWシステム
COOLING WATER SYSTEM

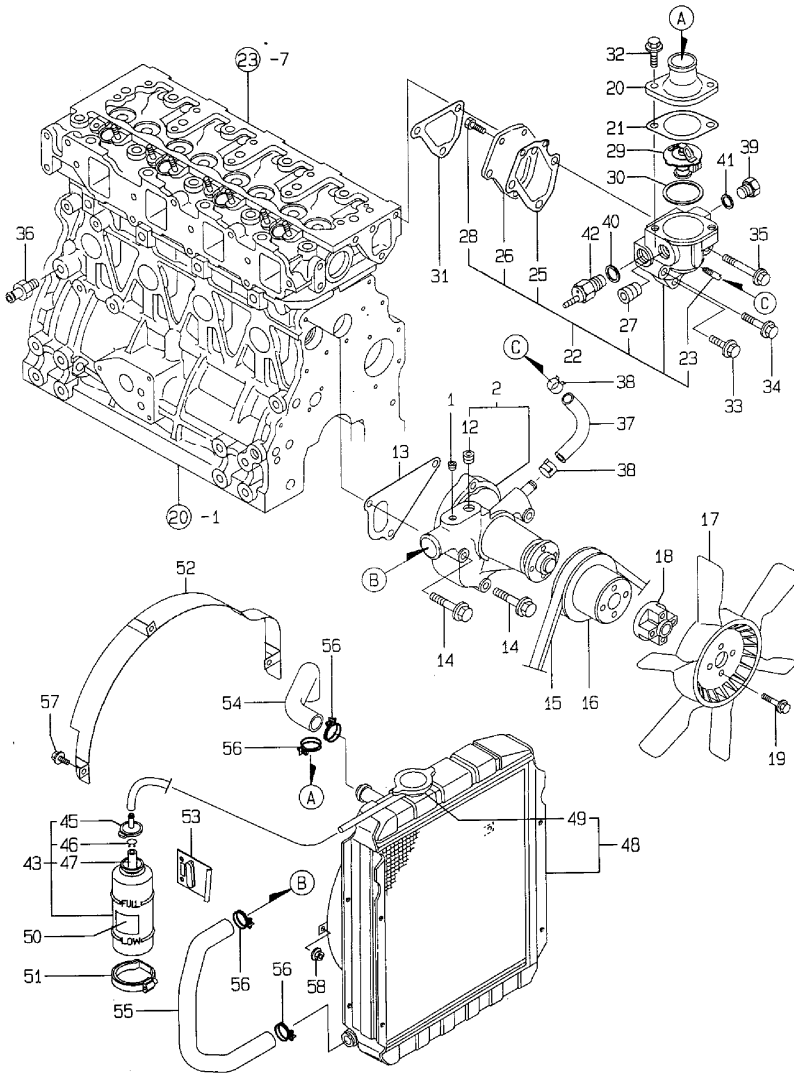

No.	Lev.	Parts No.	Description	Q'ty						I	R
				(A)	(B)	(C)	(D)	(E)	(F)		
1	1	121850-11860	PLUG, PT1/4			1					
2	1	129100-42002	PUMP ASSY, WATER			1					
12	2	23871-030000	PLUG, R03			1					
13	1	129100-42020	GASKET, WATER PUMP			1					G
14	1	26106-080602	BOLT, M8X 60 PLATED			3					
15	1	124732-42290	V-BELT, AX37			1					
16	1	129155-42350	V-PULLEY			1					
17	1	129432-44740	FAN, COOLING D370XEF			1					
18	1	171353-44760	SPACER, FAN			1					
19	1	26106-060352	BOLT, M6X 35 PLATED			4					
20	1	129350-49530	COVER, THERMOSTAT			1					
21	1	129795-49551	GASKET			1					G
22	1	129100-49800	CASE ASSY, THERMOSTAT			1					
23	2	124770-11770	JOINT, PIPE PT1/8			1					
25	2	129100-49820	GASKET			1					
26	2	129100-49830	COVER, THERMOSTAT			1					
27	2	23871-030000	PLUG, R03			1					
28	2	26116-060162	BOLT, M6X 16 PLATED			2					
29	1	129155-49800	THERMOSTAT, 71			1					
30	1	129150-49811	GASKET, THERMOSTAT			1					G
31	1	129100-49840	GASKET			1					G
32	1	26106-080202	BOLT, M8X 20 PLATED			2					
33	1	26106-080252	BOLT, M8X 25 PLATED			1					
34	1	26106-080502	BOLT, M8X 50 PLATED			1					
35	1	26106-080602	BOLT, M8X 60 PLATED			1					
36	1	121550-49111	JOINT, PT1/4			1					
37	1	129132-49050	PIPE, WATER			1					
38	1	23000-016000	CLAMP, 16			2					
39	1	121450-42450	PLUG, M16			1					
40	1	124465-44950	GASKET, 16			1					G
41	1	124465-44950	GASKET, 16			1					G
42	1	121250-44901	SWITCH, 110			1					
43	1	124450-44510	TANK ASSY, SUB			1					
45	2	124450-44530	CAP			1					
46	2	124450-44560	RETAINER			1					
47	2	23061-070230	PIPE, 7X 230			1					
48	1	129411-44510	RADIATOR			1					
49	2	124450-44590	CAP, RADIATOR			1					
50	1	121470-44540	LABEL, SUB-TANK			1					
51	1	124450-44550	BAND			1					
52	1	129411-44560	PROTECTOR, FAN			1					
53	1	121256-44600	BRACKET, SUB TANK			1					
54	1	171420-49010	PIPE, WATER			1					
55	1	171420-49020	PIPE, WATER			1					
56	1	23010-038000	CLAMP, 38			4					
57	1	26014-080202	BOLT, M8X 20			3					
58	1	26366-080002	NUT, M8			3					

Remarks
(G) THESE PARTS ARE SOLD BY
FIG.38, REF.NO.1.

Fig.30. FUEL INJECTION PUMP

(A)=3TNE84-AGD
(B)=3TNE88-AGD
(C)=4TNE88-AGD

(D)=4TNE84T-AGD
(E)=
(F)=

Y0085190
3, 4TNE84, 88 (T) -AGD

30 FO フォンシャポンプ
FUEL INJECTION PUMP

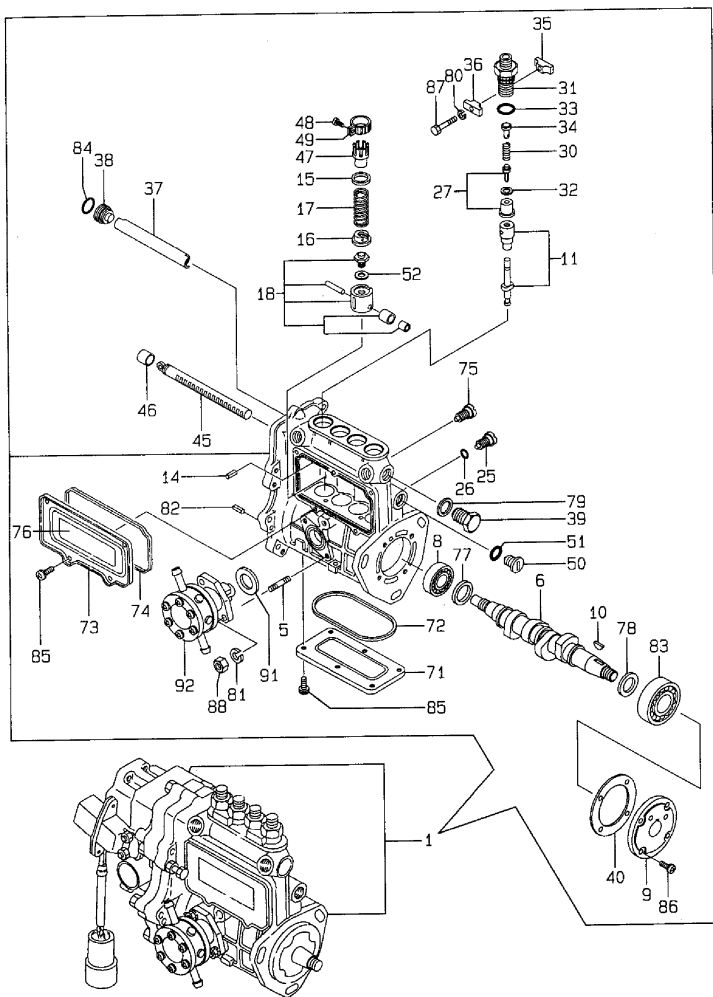

No.	Lev.	Parts No.	Description	Qty						I	R
				(A)	(B)	(C)	(D)	(E)	(F)		
1	1	729611-51210	PUMP ASSY, INJECTION	1							1
5	2	129155-51020	STUD		2						
6	2	129470-51040	CAMSHAFT		1						
8	2	129155-51050	BEARING, 17BM001D		1						
9	2	129155-51060	SUPPORT, CAMSHAFT		1						
10	2	122710-51090	KEY		1						
11	2	129506-51100	PLUNGER ASSY		4						
14	2	129155-51140	PIN		4						
15	2	174307-51170	RETAINER, SPRING A		4						
16	2	129155-51180	RETAINER, SPRING		4						
17	2	124950-51190	SPRING, PLUNGER		4						
18	2	129155-51200	TAPPET ASSY		4						
25	2	129155-51270	STOPPER, TAPPET		4						
26	2	129155-51280	O-RING, S6		4						
27	2	129100-51300	VALVE ASSY, DELIVERY		4						
30	2	129155-51320	SPRING, DELIVERY		4						
31	2	129155-51340	RETAINER		4						
32	2	124550-51350	GASKET, DELIVERY		4						
33	2	124550-51370	O-RING		4						
34	2	129155-51370	STOPPER, VALVE		4						
35	2	129155-51380	STOPPER		2						
36	2	129155-51390	STOPPER		2						
37	2	129555-51400	DEFLECTOR		1						
38	2	129155-51410	BOLT		1						
39	2	129155-51420	PLUG, M16		1						
40	2	129155-51450	SHIM SET, ADJUSTING		1						
45	2	129555-51500	RACK, CONTROL		1						
46	2	129155-51521	BUSH, RACK		1						
47	2	129155-51550	PINION, CONTROL		4						
48	2	122117-51560	SCREW		4						
49	2	174307-51560	PINION		4						
50	2	129155-51570	PLUG, M12		1						
51	2	129155-51580	O-RING		1						
52	2	129155-51600	SHIM SET, ADJUSTING		4						
71	2	129555-51700	COVER		1						
72	2	129555-51710	GASKET		1						
73	2	129555-51750	COVER		1						
74	2	129555-51760	GASKET		1						
75	2	129155-51790	STOOPER, RACK		1						
76	2	129156-51910	LABEL, CAUTION		1						
77	2	129155-51930	SPACER, T=3.25		1						
78	2	129155-51940	SPACER, T=1.5		1						
79	2	22190-160002	WASHER, SEAL 16		1						
80	2	22217-050000	WASHER, SPRING 5		2						
81	2	22217-060000	WASHER, SPRING 6		2						
82	2	22351-050010	PIN, SPRING 5.0X10		2						
83	2	24101-063034	BEARING, BALL 6303		1						
84	2	24341-000160	O-RING, 1AS16.0		1						
85	2	26022-050102	SCREW, M5X10		11						
86	2	26022-060162	SCREW, M6X16		4						
87	2	26116-050302	BOLT, M5X 30 PLATED		2						

Remarks

(1) GOVERNOR ASSY(FIG.NO.31) IS INCORPORATED IN THIS FUEL INJECTION PUMP ASSY(REF.NO.1).
(G) THESE PARTS ARE SOLD BY FIG.38, REF.NO.1.

Fig.30. FUEL INJECTION PUMP

(A)=3TNE84-AGD
(B)=3TNE88-AGD
(C)=4TNE88-AGD

(D)=4TNE84T-AGD
(E)=
(F)=

Y00B5190
3, 4TNE84, 88 (T) -AGD

30 FO フォンシャポンプ
FUEL INJECTION PUMP

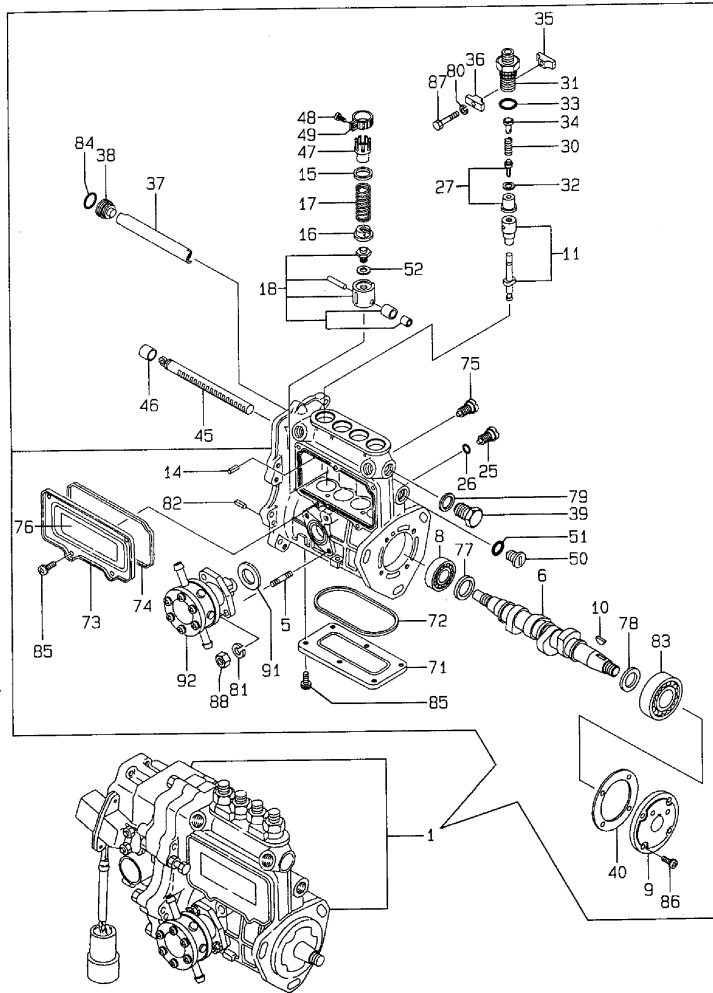

No.	Lev.	Parts No.	Description	Qty						I	R
				(A)	(B)	(C)	(D)	(E)	(F)		
88	2	26716-060002	NUT, M6			2					
91	2	129155-52050	GASKET			1					G
92	2	129100-52100	PUMP ASSY, FUEL FEED			1					

Remarks

(1) GOVERNOR ASSY(FIG.NO.31) IS
INCORPORATED IN THIS FUEL
INJECTION PUMP ASSY(REF.NO.1).
(G) THESE PARTS ARE SOLD BY FIG.38,
REF.NO.1.

Fig.31. GOVERNOR

(A)=3TNE84-AGD
(B)=3TNE88-AGD
(C)=4TNE88-AGD

(D)=4TNE84T-AGD
(E)=
(F)=

Y00B5190
3, 4TNE84, 88 (T) -AGD

31 弁
GOVERNOR

No.	Lev.	Parts No.	Description	Q'ty						I	R
				(A)	(B)	(C)	(D)	(E)	(F)		
2	2	129116-61051	GASKET			1					
3	2	119649-61100	ACTUATOR			1					
6	2	129116-61110	SPACER			1					
7	2	129116-61120	LINK			1					
8	2	119649-61151	GASKET			1					
9	2	22117-040000	WASHER, 4			2					
10	2	22351-040010	PIN, SPRING 4.0X10			2					
11	2	22360-050000	SNAP PIN 5			2					
12	2	26106-060202	BOLT, M6X 20 PLATED			1					
13	2	26106-060222	BOLT, M6X 22 PLATED			7					
14	2	26106-060452	BOLT, M6X 45 PLATED			2					
15	2	26106-060602	BOLT, M6X 60 PLATED			1					
16	2	26106-060702	BOLT, M6X 70 PLATED			1					
17	2	26106-060852	BOLT, M6X 85 PLATED			1					

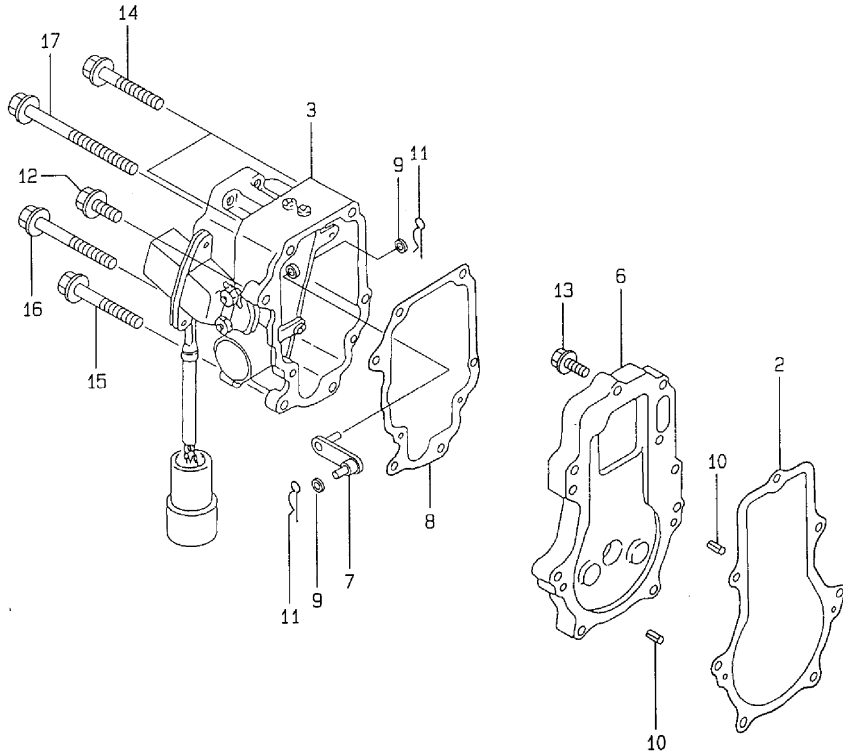
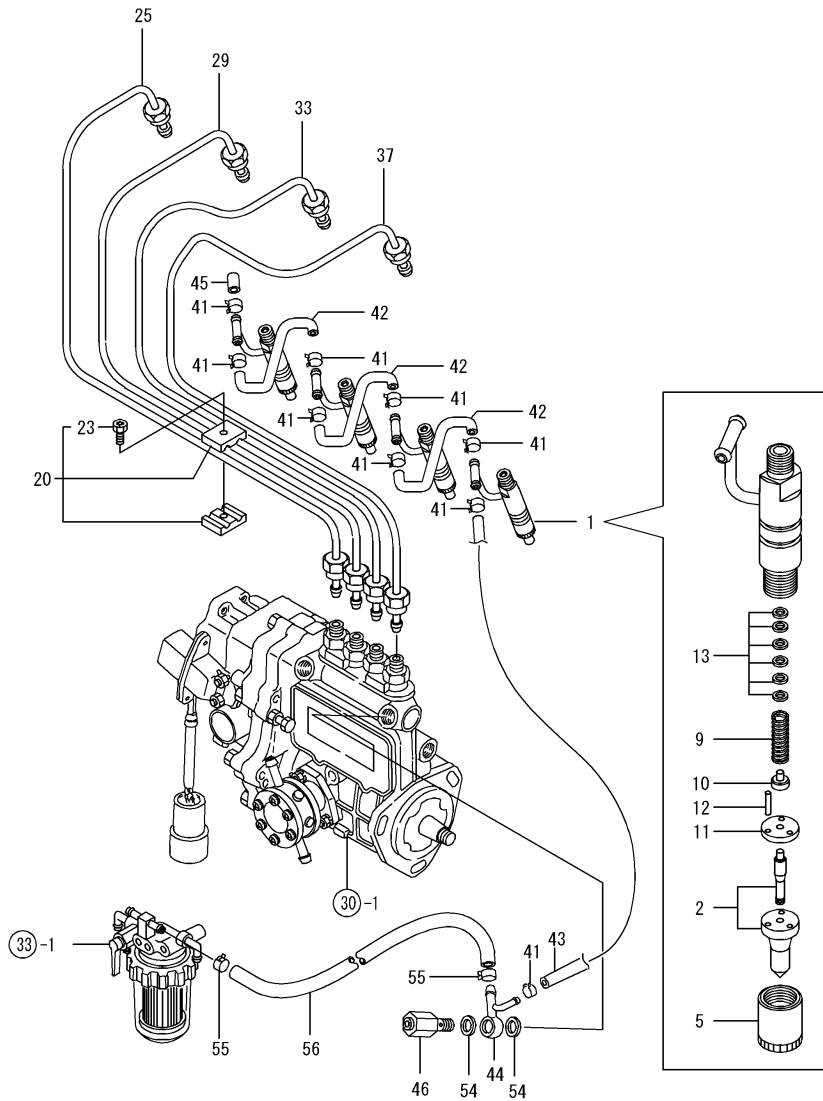

Fig.32. FUEL INJECTION VALVE

(A)=3TNE84-AGD
(B)=3TNE88-AGD
(C)=4TNE88-AGD

(D)=4TNE84T-AGD
(E)=
(F)=



No.	Lev.	Parts No.	Description	Qty						I	R
				(A)	(B)	(C)	(D)	(E)	(F)		
1	1	719810-53100	VALVE ASSY,INJECTION			4					
2	2	119810-53000	VALVE ASSY,INJECTION			4					
5	2	114250-53080	NUT, NOZZLE D16.95			4					
9	2	114250-53120	SPRING, NOZZLE			4					
10	2	114250-53130	SEAT, SPRING			4					
11	2	114250-53140	PLATE			4					
12	2	114250-53210	PIN			8					
13	2	114250-53400	SHIM SET			4					
20	1	119305-59120	RETAINER, PIPE			2					
23	2	129150-59131	BOLT, M4X14			2					
25	1	129408-59810	PIPE ASSY, INJECTION			1					
29	1	129408-59820	PIPE ASSY, INJECTION			1					
33	1	129408-59830	PIPE ASSY, INJECTION			1					
37	1	129408-59840	PIPE ASSY, INJECTION			1					
41	1	124066-59100	CLIP, HOSE 8			9					
42	1	121250-59550	PIPE, FUEL D8X120			3					
43	1	119840-59560	PIPE, FUEL RETURN			1					
44	1	119840-59570	JOINT			1					
45	1	129150-59580	CAP			1					
46	1	129100-59951	VALVE ASSY, CHECK			1					
54	1	23414-120000	GASKET, 12X1.0			2					G
55	1	124766-59050	CLIP, HOSE 12			2					
56	1	105025-59530	PIPE, FUEL D13X400			1					

Remarks
(G) THESE PARTS ARE SOLD BY
FIG.38,REF.NO.1.

Fig.33. FUEL LINE

(A)=3TNE84-AGD
(B)=3TNE88-AGD
(C)=4TNE88-AGD

(D)=4TNE84T-AGD
(E)=
(F)=

Y0085190
3, 4TNE84, 88 (T) -AGD

33 FUEL LINE

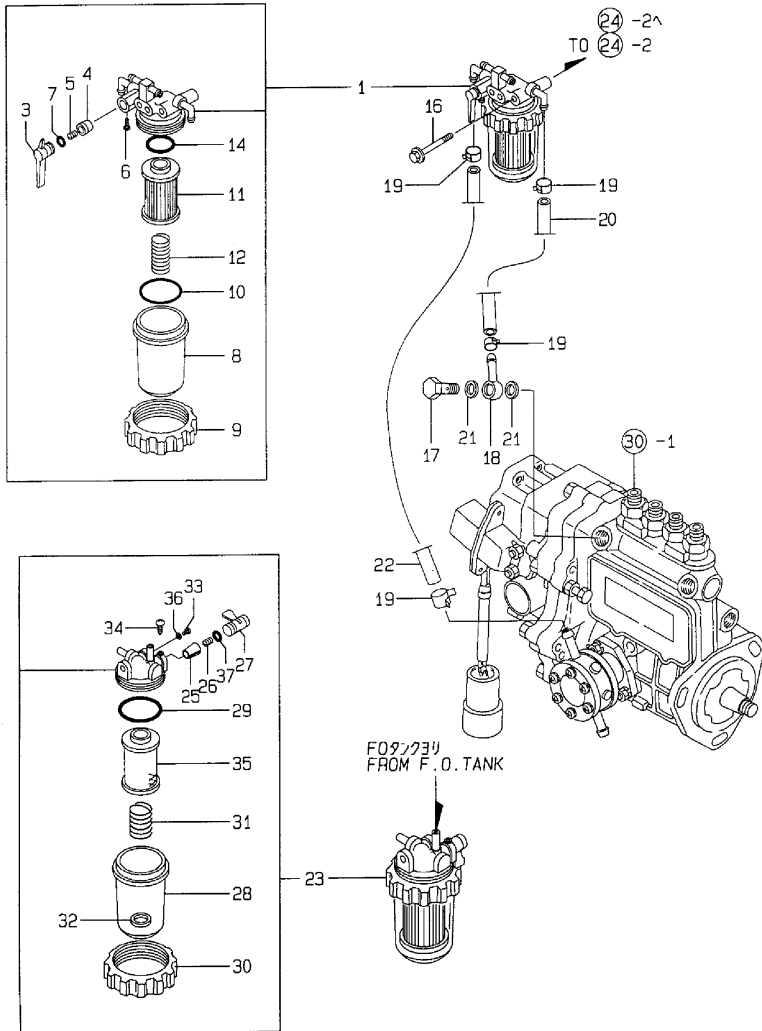

No.	Lev.	Parts No.	Description	Qty						I	R
				(A)	(B)	(C)	(D)	(E)	(F)		
1	1	129052-55620	FILTER ASSY, FUEL			1					
3	2	129100-55670	LEVER			1					
4	2	104200-55321	VALVE, TAPER			1					
5	2	104200-55330	SPRING, VALVE			1					
6	2	104200-55750	SCREW, M4			1					
7	2	24311-240100	O-RING, 1AP10A			1					
8	2	129100-55680	CUP, STRAINER			1					
9	2	129100-55690	RING, RETAINING			1					
10	2	24321-000650	O-RING, 1AG65.0			1					G
11	2	129100-55650	ELEMENT			1					
12	2	129100-55700	SPRING			1					
14	2	24311-000160	O-RING, 1AP16.0			1					
16	1	26014-080702	BOLT, M8X 70			1					
17	1	103854-39140	BOLT, PIPE JOINT			1					
18	1	101304-59020	JOINT, PIPE 12			1					
19	1	124766-59050	CLIP, HOSE 12			4					
20	1	129555-59510	PIPE, D13/7.5X180			1					
21	1	104200-59170	GASKET, 12			2					G
22	1	105025-59530	PIPE, FUEL D13X400			1					
23	1	121257-55700	SEPARATOR, WATER			1					
25	2	104200-55321	VALVE, TAPER			1					
26	2	104200-55330	SPRING, VALVE			1					
27	2	104200-55341	HANDLE			1					
28	2	121254-55510	COVER			1					
29	2	102103-55520	O-RING			1					
30	2	110250-55610	RING, RETAINING			1					
31	2	121257-55720	SPRING			1					
32	2	121257-55731	FLOAT			1					
33	2	101720-55750	PLUG, 6			2					
34	2	104200-55750	SCREW, M4			1					
35	2	171081-55910	SCREEN			1					
36	2	23418-060000	GASKET, 6X1.0			2					
37	2	24311-240100	O-RING, 1AP10A			1					

Remarks
(G) THESE PARTS ARE SOLD BY
FIG.38,REF.NO.1.

Fig.34. STARTING MOTOR

Y00B5190
3, 4TNE84, 88 (T) -AGD

34 スターティングモーター
STARTING MOTOR

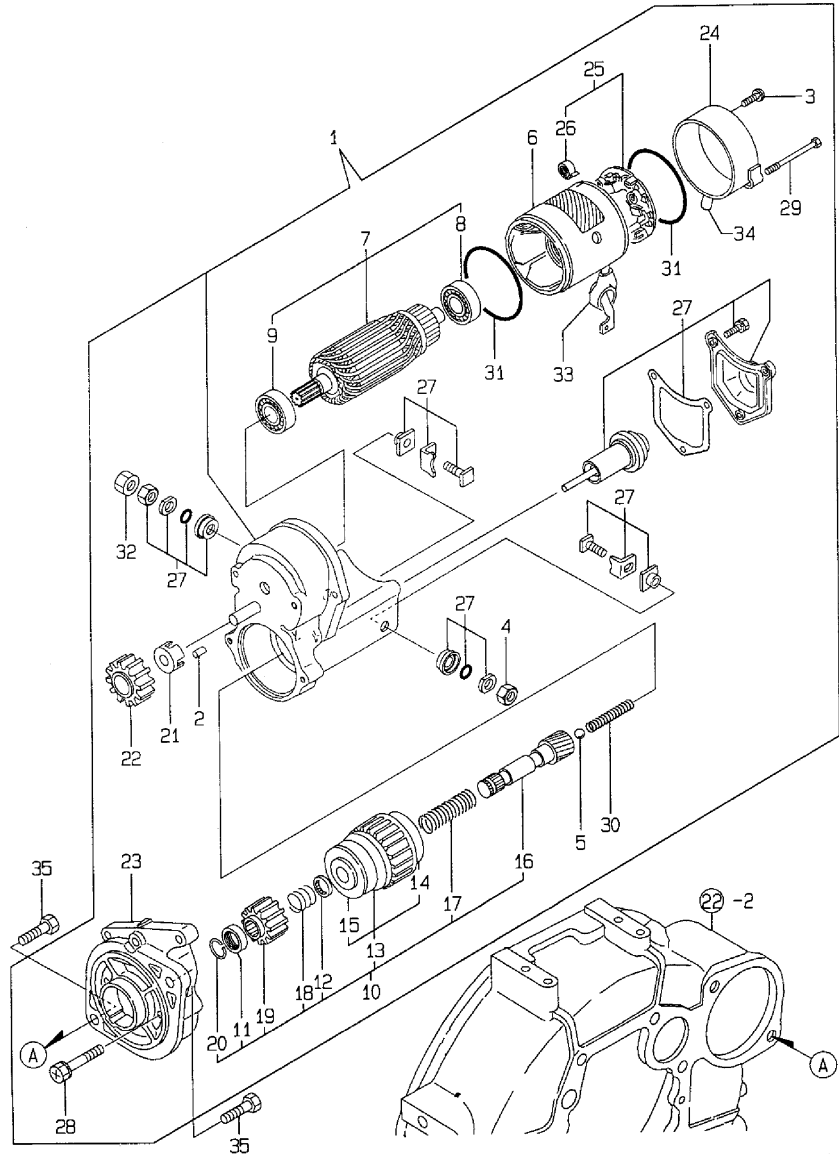

(A)=3TNE84-AGD
(B)=3TNE88-AGD
(C)=4TNE88-AGD

(D)=4TNE84T-AGD
(E)=
(F)=

No.	Lev.	Parts No.	Description	Qty						I	R
				(A)	(B)	(C)	(D)	(E)	(F)		
1	1	129407-77010	STARTER, RA1.4			1					
2	2	X0283060061	ROLLER			5					
3	2	X0289030010	SCREW			2					
4	2	X9490561370	NUT			1					
5	2	X9491200240	BALL			1					
6	2	129407-77210	YOKE ASSY			1					
7	2	129407-77220	ARMATURE ASSY			1					
8	3	129129-77230	BEARING			1					
9	3	129129-77240	BEARING			1					
10	2	129407-77250	STARTER			1					
11	3	X0280210230	NUT			1					
12	3	X0283270140	RETAINER			1					
13	3	129407-77390	CLUTCH ASSY			1					
14	4	129129-77440	BEARING, BALL			1					
15	4	129129-77450	BEARING, BALL			1					
16	3	129129-77400	SHAFT			1					
17	3	129129-77410	SPRING, COIL			1					
18	3	129407-77410	SPRING			1					
19	3	129129-77420	PINION, STARTER			1					
20	3	129129-77430	RING			1					
21	2	129129-77260	RETAINER			1					
22	2	129129-77270	PINION			1					
23	2	129407-77280	HOUSING			1					
24	2	129129-77290	FRAME			1					
25	2	129407-77300	HOLDER ASSY			1					
26	3	X9491730461	SPRING			4					
27	2	129407-77310	SWITCH ASSY			1					
28	2	129129-77320	BOLT			2					
29	2	129407-77330	BOLT			2					
30	2	129129-77340	SPRING			1					
31	2	129129-77350	O-RING			2					
32	2	129129-77370	NUT			1					
33	2	129129-77380	CAP			1					
34	2	129129-77361	BUSH			1					
35	1	26116-120252	BOLT, M12X 25 PLATED			2					

Fig.35. GENERATOR

(A)=3TNE84-AGD
(B)=3TNE88-AGD
(C)=4TNE88-AGD

(D)=4TNE84T-AGD
(E)=
(F)=

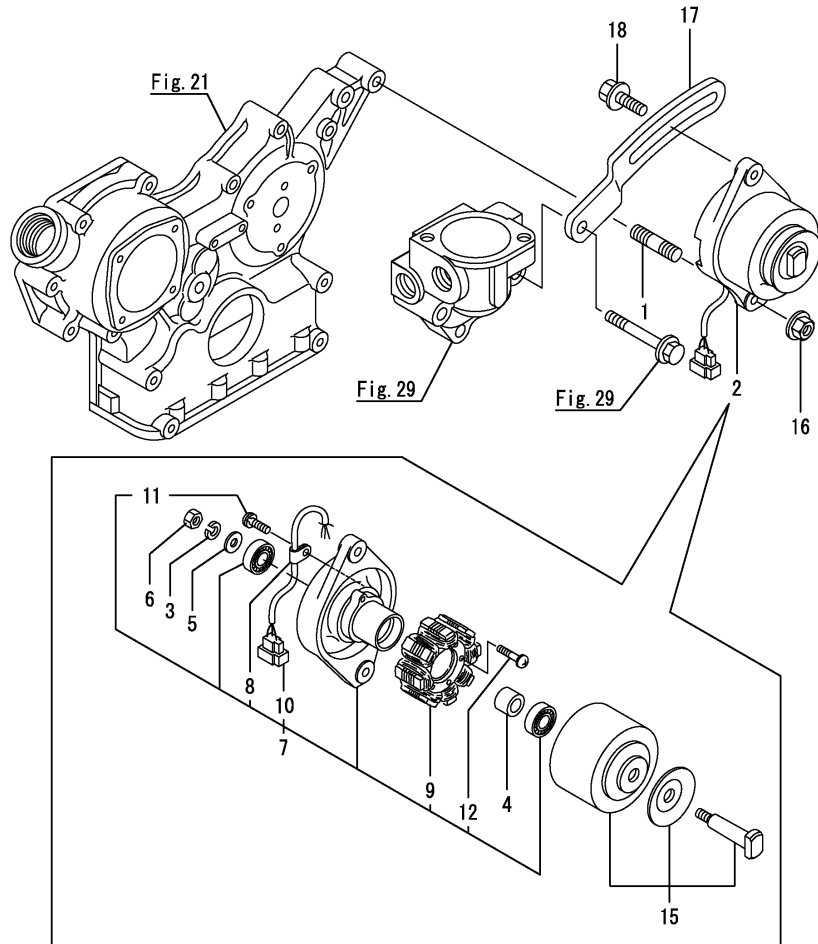

No.	Lev.	Parts No.	Description	Qty						I	R
				(A)	(B)	(C)	(D)	(E)	(F)		
1	1	121450-01570	BOLT, STUD			1					
2	1	129150-77202	GENERATOR			1					
2-1	1	129150-77203	DINAMO ASSY			1					N
			(C=EXXXXX)								
3	2	XM219230000	WASHER, SPRING			1					
4	2	XM329830000	COLLAR			1					
5	2	XM860250000	WASHER, 10			1					
6	2	XM863720000	NUT			1					
7	2	129150-77210	PLATE ASSY			1					
8	3	XM069000000	CLAMP			1					
9	3	XM081780000	STATOR			1					
10	3	XM178780000	COUPLER			1					
11	3	XYSPS400800	SCREW			1					
12	3	XYSPS402400	SCREW			2					
15	2	129150-77230	FLYWHEEL ASSY			1					
15-1	2	129150-77280	FLYWHEEL ASSY			1					N
			(C=EXXXXX)								
16	1	26366-100002	NUT, M10			1					
17	1	129410-77330	ADJUSTER, BELT			1					
18	1	26014-080252	BOLT, M8X 25			1					

Fig.36. PULSER

Y00B5190
3, 4TNE84, 88 (T) -AGD

36 パルサー
PULSER

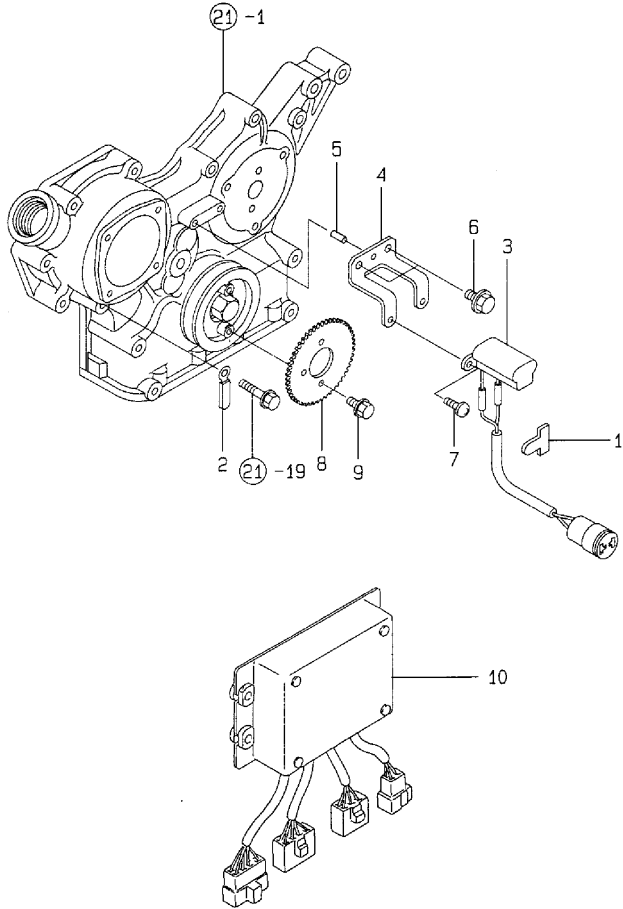

(A)=3TNE84-AGD
(B)=3TNE88-AGD
(C)=4TNE88-AGD

(D)=4TNE84T-AGD
(E)=
(F)=

No.	Lev.	Parts No.	Description	Qty						I	R
				(A)	(B)	(C)	(D)	(E)	(F)		
1	1	172010-08160	STICKER, WIRE			1					
2	1	194180-51640	CLAMP, HARNESS			1					
3	1	119649-78500	PULSAR			1					
4	1	129116-78510	BRACKET, PULSAR			1					
5	1	22351-040010	PIN, SPRING 4.0X10			1					
6	1	26116-060122	BOLT, M6X 12 PLATED			2					
7	1	26557-040082	SCREW, M4X 8			2					
8	1	119649-78650	GEAR, PULSAR			1					
9	1	26106-100142	BOLT, M10X 14 PLATED			2					
10	1	129111-78802	CONTROLLER, MAIN 4P			1					

Fig.37. ELECTRIC PARTS

(A)=3TNE84-AGD
(B)=3TNE88-AGD
(C)=4TNE88-AGD

(D)=4TNE84T-AGD
(E)=
(F)=

Y00B5190
3, 4TNE84, 88 (T) -AGD

37 デンソウヒン
ELECTRIC PARTS

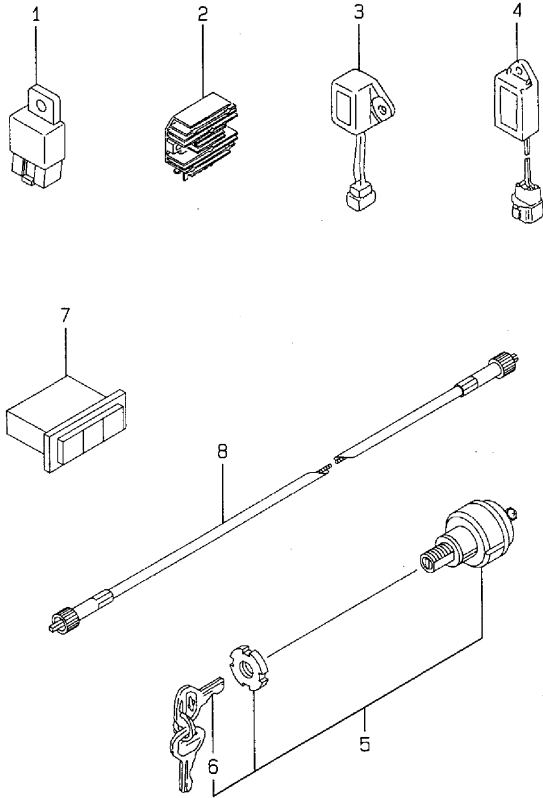

No.	Lev.	Parts No.	Description	Q'ty						I	R
				(A)	(B)	(C)	(D)	(E)	(F)		
1	1	119247-77100	RELAY, SAFETY	1							
2	1	119640-77711	LIMITER, CURRENT	1							
3	1	121522-77721	INDICATOR	1							
4	1	128300-77920	TIMER	1							
5	1	121400-91251	SWITCH, STARTER	1							
6	2	121400-91271	KEY, SWITCH	1							
7	1	129411-91310	LAMP	1							
7A	2	129411-91360	BULB, 12V-3.4W	6							W
8	1	194185-56900	CABLE ASSY, METER	1							

Fig.38. GASKET SET(OPTIONAL) & TOOL

(A)=3TNE84-AGD
(B)=3TNE88-AGD
(C)=4TNE88-AGD

(D)=4TNE84T-AGD
(E)=
(F)=

Y00B5190
3, 4TNE84, 88 (T) -AGD

38 パッキンセット (オプション) & コウク
GASKET SET (OPTIONAL) & TOOL

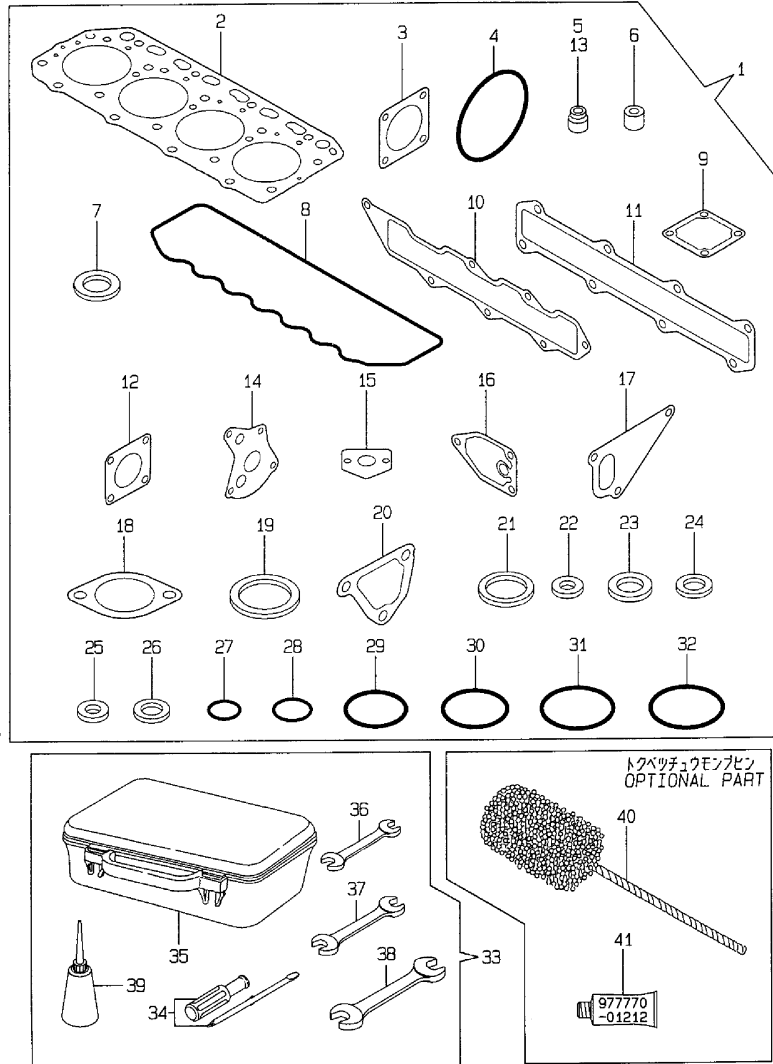

No.	Lev.	Parts No.	Description	Qty						I	R
				(A)	(B)	(C)	(D)	(E)	(F)		
1	1	729611-92600	GASKET SET			1					1
2	2	129407-01340	GASKET, HEAD			1					
3	2	124240-01883	GASKET			1					
4	2	121850-51960	O-RING			1					
5	2	124460-11340	SEAL, VALVE STEM			4					
6	2	119625-11871	PROTECTOR, NOZZLE			4					
7	2	119625-11880	SEAT, NOZZLE			4					
8	2	129550-11310	GASKET, BONNET			1					
9	2	129150-77511	GASKET			1					
10	2	129407-12110	GASKET, MANIFOLD			1					
11	2	129407-13110	GASKET			1					
12	2	129400-13201	GASKET, SILENCER			1					
13	2	121400-11340	SEAL, VALVE STEM			4					
14	2	129150-32020	GASKET, PUMP			1					
15	2	129150-35041	GASKET			1					
16	2	129150-35111	GASKET			1					
17	2	129100-42020	GASKET, WATER PUMP			1					
18	2	129795-49551	GASKET			1					
19	2	129150-49811	GASKET, THERMOSTAT			1					
20	2	129100-49840	GASKET			1					
21	2	129155-52050	GASKET			1					
22	2	104200-59170	GASKET, 12			4					
23	2	22190-080002	WASHER, SEAL 6			7					
24	2	23414-100000	GASKET, 10X1.0			2					
25	2	124465-44950	GASKET, 16			1					
26	2	23414-120000	GASKET, 12X1.0			2					
27	2	24311-000120	O-RING, 1AP12.0			3					
28	2	24311-000160	O-RING, 1AP16.0			3					
29	2	24311-000320	O-RING, 1AP32.0			2					
30	2	24341-000240	O-RING, 1AS24.0			1					
31	2	24341-000500	O-RING, 1AS50.0			1					
32	2	24321-000650	O-RING, 1AG65.0			1					G
33	1	171001-93100	BOX, TOOL			1					
34	2	104200-92350	DRIVER, SCREW			1					
35	2	104200-92600	BOX, TOOL			1					
36	2	28110-100120	SPANNER, 10X12			1					
37	2	28110-140170	SPANNER, 14X17			1					
38	2	28110-190220	SPANNER, 19X22			1					
39	2	28210-000140	OILER			1					
40	1	129400-92420	HONE			1					1
41	1	977770-01212	GASKET, LIQUID			1					1

Remarks

(1) OPTIONAL PART.

Fig.39. CYLINDER BLOCK

(A)=3TNE84-AGD
(B)=3TNE88-AGD
(C)=4TNE88-AGD

(D)=4TNE84T-AGD
(E)=
(F)=

Y0085190
3, 4TNE84, 88 (7) -AGD

39 シリンダブロック
CYLINDER BLOCK

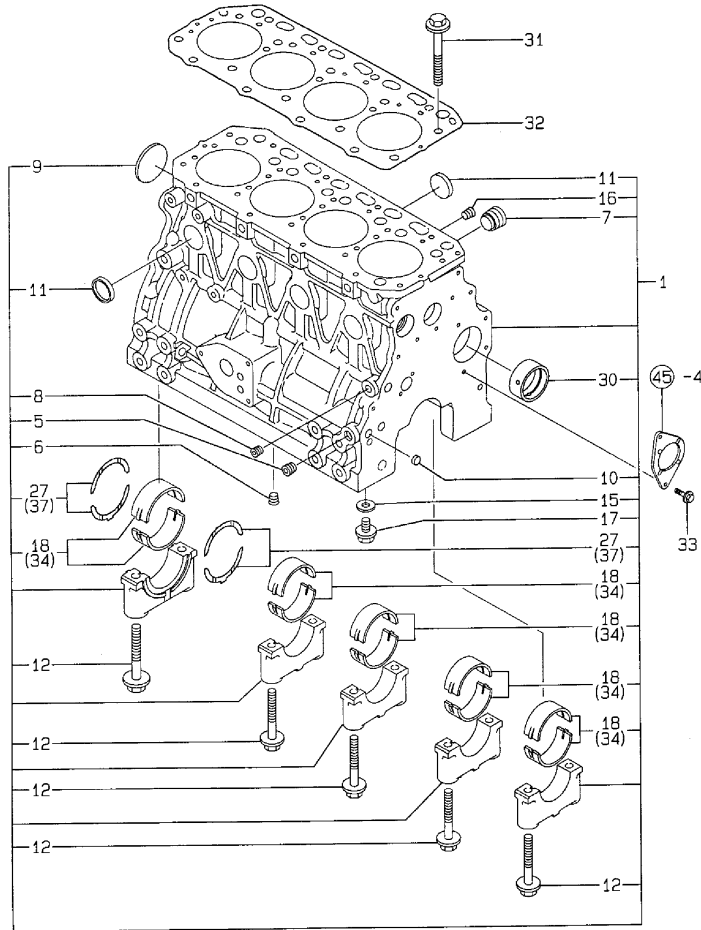

No.	Lev.	Parts No.	Description	Q'ty						I	R	
				(A)	(B)	(C)	(D)	(E)	(F)			
1	1	729408-01560	BLOCK ASSY, CYLINDER				1					
5	2	124160-01910	PLUG, PT1/4				2					
6	2	124160-01910	PLUG, PT1/4				1					
7	2	171051-01921	PLUG, NPTF1				1					
8	2	23871-010000	PLUG, R01				1					
9	2	27231-500000	PLUG 50				1					
10	2	27241-120000	PLUG, 12				2					
11	2	27241-300000	PLUG 30				8					
12	2	129150-02020	BOLT, METAL CAP				10					
15	2	23414-080000	GASKET, 8X1.0				4					
16	2	23871-030000	PLUG, R03				1					
17	2	26106-080122	BOLT, M8X 12 PLATED				4					
18	2	129001-02800	BEARING, MAIN				5					
27	2	129150-02930	BEARING, THRUST				2					
30	2	129795-02411	BUSH, CAMSHAFT				1					
31	1	129150-01200	BOLT, HEAD				18					
32	1	129408-01330	GASKET, HEAD				1					G
33	1	26106-080162	BOLT, M8X 16 PLATED				2					
34	1	129150-02870	BEARING, 0.25 US				5					1
37	1	129150-02940	BEARING, THRUST 0.25				2					2

Remarks

- (1) UNDER-SIZED(U.S=0.25)PART.
- (2) OVER-SIZED(O.S=0.25)PART.
- (G) THESE PARTS ARE SOLD BY FIG.59,REF.NO.1.

Fig.40. GEAR HOUSING

(A)=3TNE84-AGD
(B)=3TNE88-AGD
(C)=4TNE88-AGD

(D)=4TNE84T-AGD
(E)=
(F)=

Y00B5190
3, 4TNE84, 88 (T) -AGD

40 ギヤケース
GEAR HOUSING

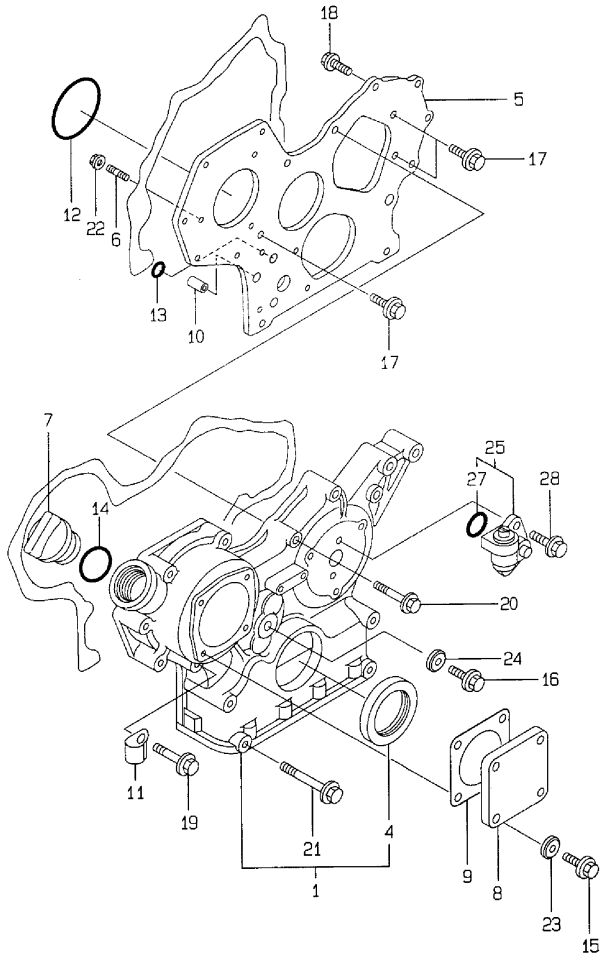

No.	Lev.	Parts No.	Description	Q'ty						I	R
				(A)	(B)	(C)	(D)	(E)	(F)		
1	1	719810-01500	CASE ASSY, GEAR				1				
4	2	129795-01800	SEAL, OIL				1				
5	1	129400-01520	FLANGE, GEAR CASE				1				
6	1	121450-01560	STUD, M8X22				3				
7	1	124160-01751	COVER, FILLER				1				
8	1	124240-01871	COVER				1				
9	1	124240-01883	GASKET				1				G
10	1	129795-01950	PIPE, KNOCK L=18				2				
11	1	129150-03100	RETAINER, PIPE				1				
12	1	121850-51960	O-RING				1				G
13	1	24311-000160	O-RING, 1AP16.0				2				G
14	1	24311-000320	O-RING, 1AP32.0				1				G
15	1	26106-080122	BOLT, M8X 12 PLATED				4				
16	1	26106-080162	BOLT, M8X 16 PLATED				1				
17	1	26106-080162	BOLT, M8X 16 PLATED				3				
18	1	26106-080202	BOLT, M8X 20 PLATED				2				
19	1	26106-080452	BOLT, M8X 45 PLATED				6				
20	1	26106-080552	BOLT, M8X 55 PLATED				3				
21	1	26106-080852	BOLT, M8X 85 PLATED				4				
22	1	26366-080002	NUT, M8				3				
23	1	22190-080002	WASHER, SEAL 6				4				G
24	1	22190-080002	WASHER, SEAL 6				1				G
25	1	129150-91400	GEAR				1				
27	2	24341-000240	O-RING, 1AS24.0				1				G
28	1	26106-060162	BOLT, M6X 16 PLATED				2				

Remarks
(G) THESE PARTS ARE SOLD BY
FIG.59,REF.NO.1.

Fig.41. FLYWHEEL HOUSING & OIL SUMP

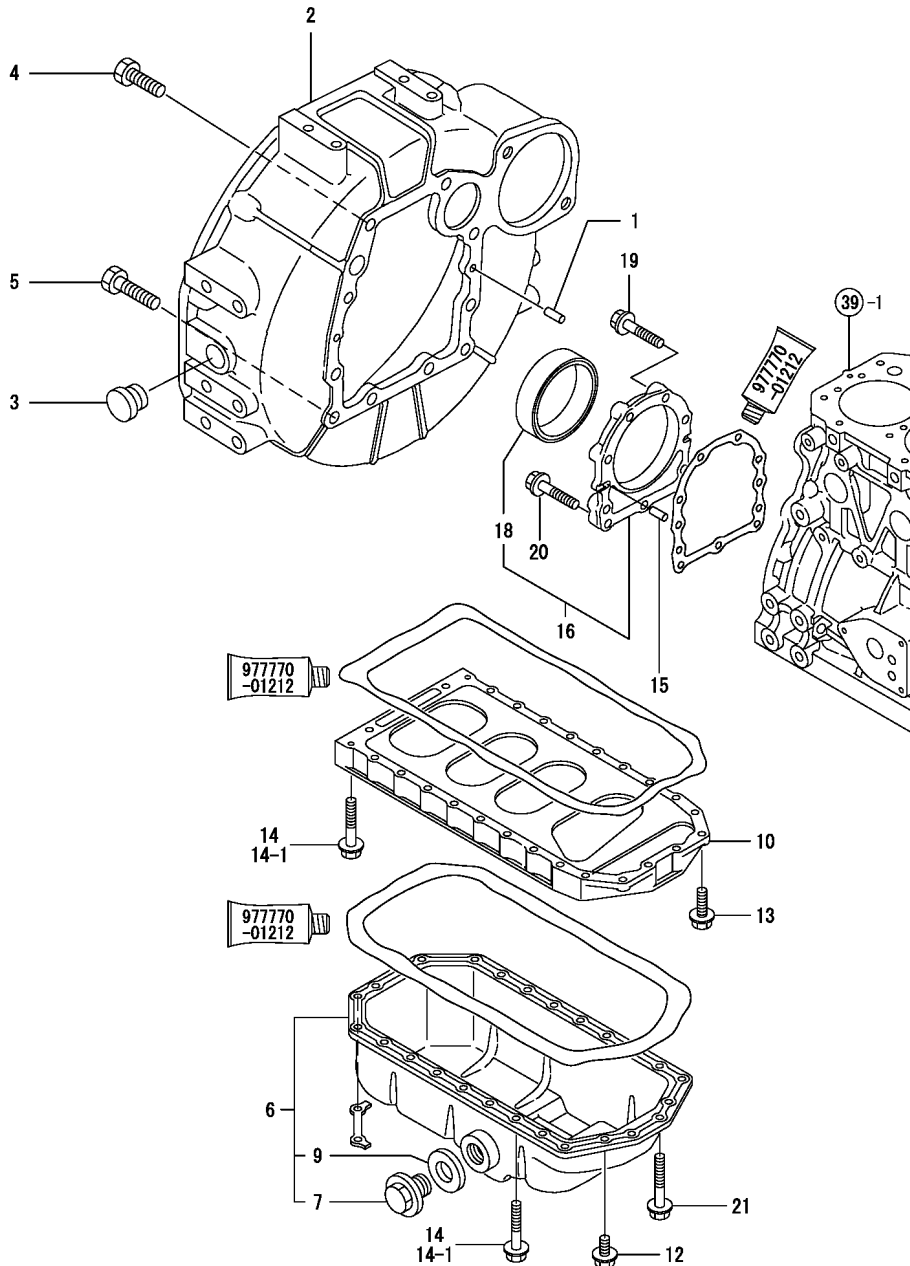

(A)=3TNE84-AGD
(B)=3TNE88-AGD
(C)=4TNE88-AGD

(D)=4TNE84T-AGD
(E)=
(F)=

No.	Lev.	Parts No.	Description	Q'ty						I	R
				(A)	(B)	(C)	(D)	(E)	(F)		
1	1	129100-01580	PIN, M8X16				2				
2	1	171420-01600	HOUSING, FLYWHEEL				1				
3	1	119620-01750	CAP				1				
4	1	26206-100252	BOLT, M10X 25 PLATED				6				
5	1	26206-100302	BOLT, M10X 30 PLATED				4				
6	1	129400-01770	SUMP ASSY, OIL				1				
7	2	119640-01640	PLUG, DRAIN M22				1				
9	2	22190-220002	WASHER, SEAL 22				1				
10	1	129400-01730	SPACER, OIL SUMP				1				
12	1	26106-080162	BOLT, M8X 16 PLATED				4				
13	1	26106-080252	BOLT, M8X 25 PLATED				2				
14	1	26106-080452	BOLT, M8X 45 PLATED				24				
14-1	1	26106-080452	BOLT, M8X 45 PLATED				20				K
			(D=FROM 1ST)								
15	1	129100-01580	PIN, M8X16				2				
16	1	129100-01640	CASE ASSY, OIL SEAL				1				
18	2	129795-01780	SEAL, OIL				1				
19	1	26106-080302	BOLT, M8X 30 PLATED				6				
20	1	26106-080352	BOLT, M8X 35 PLATED				3				
21	1	26106-080502	BOLT, M8X 50 PLATED				4				W
			(D=FROM 1ST)								

Fig.42. CYLINDER HEAD & BONNET

(A)=3TNE84-AGD
(B)=3TNE88-AGD
(C)=4TNE88-AGD

(D)=4TNE84T-AGD
(E)=
(F)=

Y00B5190
3, 4TNE84, 88 (T) -AGD

42 シリンダヘッド & ボンネット
CYLINDER HEAD & BONNET

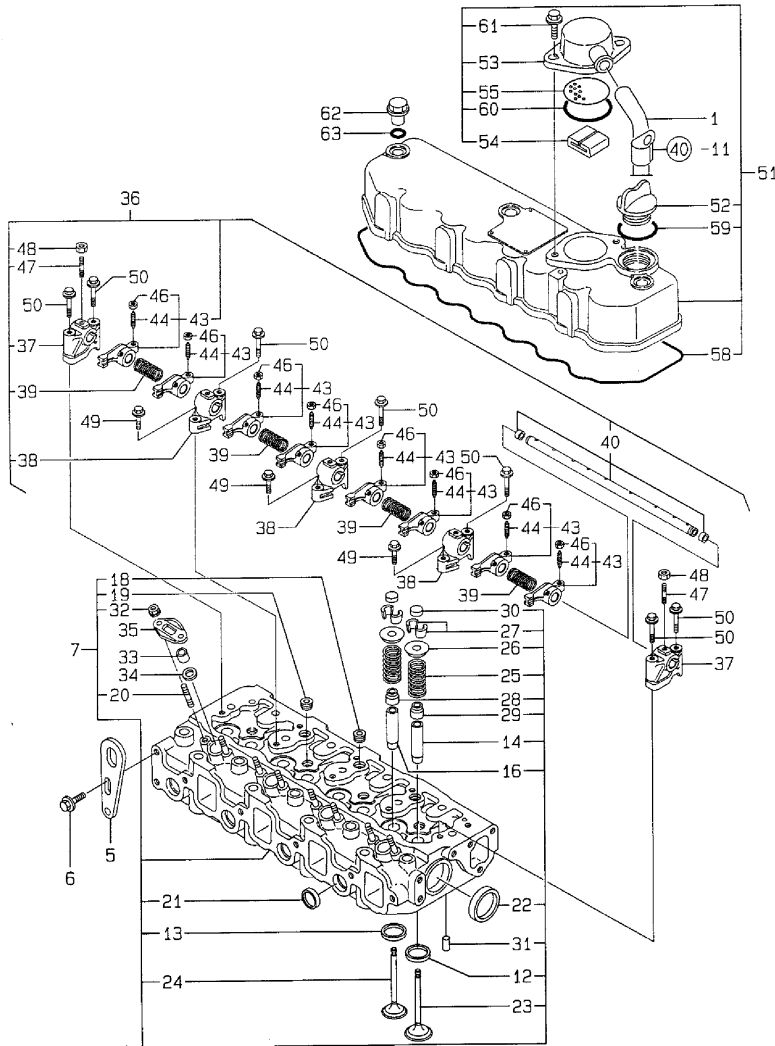

No.	Lev.	Parts No.	Description	Q'ty						I	R
				(A)	(B)	(C)	(D)	(E)	(F)		
1	1	171350-03090	PIPE , BREATHER 900				1				
5	1	124736-07900	LIFTER				2				
6	1	26106-080142	BOLT, M8X 14 PLATED				4				
7	1	729408-11700	HEAD ASSY, CYLINDER				1				
12	2	129470-11080	SEAT, INTAKE VALVE				4				
13	2	129470-11090	SEAT, EXHAUST VALVE				4				
14	2	120130-11860	GUIDE, VALVE				4				1
16	2	129150-11810	GUIDE, VALVE				4				1
18	2	121850-11860	PLUG, PT1/4				3				
19	2	23871-030000	PLUG, R03				4				
20	2	26216-060202	STUD, M6X 20				8				
21	2	27241-220000	PLUG, 22				4				
22	2	27241-400000	PLUG, 40				2				
23	2	129100-11100	VALVE, INTAKE				4				
24	2	129100-11130	VALVE, EXHAUST				4				
25	2	129795-11120	SPRING, VALVE				8				
26	2	129795-11180	RETAINER, SPRING				8				
27	2	27310-080001	COTTER, 8				8				
28	2	121400-11340	SEAL, VALVE STEM				4				G
29	2	124460-11340	SEAL, VALVE STEM				4				G
30	2	129150-11370	CAP, VALVE				8				
31	2	22351-060012	PIN, SPRING 6.0X12				2				
32	2	26366-060002	NUT, M6				8				
33	1	119625-11871	PROTECTOR, NOZZLE				4				G
34	1	119625-11880	SEAT, NOZZLE				4				G
35	1	119625-11900	RETAINER, NOZZLE				4				
36	1	129500-11240	SHAFT ASSY, ROCKER				1				
37	2	129155-11260	SUPPORT, ROCKER ARM				2				
38	2	129155-11270	SUPPORT, ROCKER ARM				3				
39	2	129150-11280	SPRING				4				
40	2	129550-11290	SHAFT, ROCKER ARM				1				
43	2	129100-11650	ARM, ROCKER				8				
44	3	129150-11230	SCREW, VALVE ADJUST				8				
46	3	129150-11750	NUT, M8				8				
47	2	26226-080182	STUD, M8X 18				3				
48	2	26756-080002	NUT, LOCK M8				3				
49	1	26106-080252	BOLT, M8X 25 PLATED				3				
50	1	26106-080502	BOLT, M8X 50 PLATED				7				
51	1	129400-11350	BONNET ASSY, HEAD				1				
52	2	124160-01751	COVER, FILLER				1				
53	2	129150-03020	COVER, BREATHER				1				
54	2	129150-03070	BAFFLE, BREATHER				1				
55	2	129150-03080	PLATE, BAFFLE				1				
58	2	129550-11310	GASKET, BONNET				1				G
59	2	24311-000320	O-RING, 1AP32.0				1				G
60	2	24341-000500	O-RING, 1AS50.0				1				G
61	2	26106-080162	BOLT, M8X 16 PLATED				2				
62	1	124160-11360	KNOB				3				
63	1	24311-000120	O-RING, 1AP12.0				3				G

Remarks

(1) REPAIR PART.
(G) THESE PARTS ARE SOLD BY
FIG.59,REF.NO.1.

Fig.43. SUCTION MANIFOLD

(A)=3TNE84-AGD
(B)=3TNE88-AGD
(C)=4TNE88-AGD

(D)=4TNE84T-AGD
(E)=
(F)=

Y0085190
3, 4TNE84, 88 (T) -AGD

43 キュウキマニホールド
SUCTION MANIFOLD

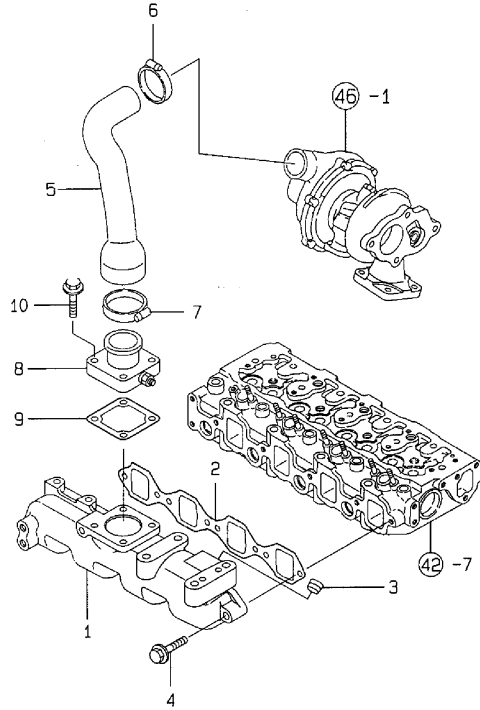

No.	Lev.	Parts No.	Description	Q'ty						I	R	
				(A)	(B)	(C)	(D)	(E)	(F)			
1	1	129400-12100	MANIFOLD, AIR INTAKE				1					
2	1	129550-12111	GASKET, MANIFOLD				1					G
3	1	23871-030000	PLUG, R03				1					
4	1	26106-080352	BOLT, M8X 35 PLATED				5					
5	1	129403-12080	PIPE, AIR INTAKE				1					
6	1	23000-054000	CLAMP, 54				1					
7	1	23000-060000	CLAMP, 60				1					
8	1	129120-77501	HEATER				1					
9	1	129150-77511	GASKET				1					G
10	1	26106-080352	BOLT, M8X 35 PLATED				4					

Remarks
(G) THESE PARTS ARE SOLD BY
FIG.59,REF.NO.1.

Fig.44. EXHAUST MANIFOLD

(A)=3TNE84-AGD
(B)=3TNE88-AGD
(C)=4TNE88-AGD

(D)=4TNE84T-AGD
(E)=
(F)=

Y00B5190
3, 4TNE84, 88 (T) -AGD

44 ハイキマニホールド
EXHAUST MANIFOLD

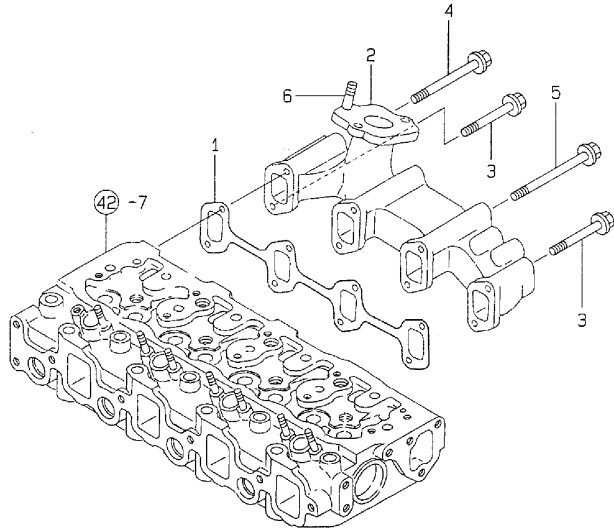

No.	Lev.	Parts No.	Description	Q'ty						I	R	
				(A)	(B)	(C)	(D)	(E)	(F)			
1	1	129550-13110	GASKET				1					G
2	1	129403-13130	MANIFOLD, EXHAUST				1					
3	1	26106-080652	BOLT, M8X 65 PLATED				3					
3-1	1	119802-13650	BOLT, M8X65 (D=*2002.09)				3					N
4	1	26106-080852	BOLT, M8X 85 PLATED				1					
4-1	1	119802-13670	BOLT, M8X85 (D=*2002.09)				1					N
5	1	26106-081002	BOLT, M8X100 PLATED				4					
5-1	1	129693-44310	BOLT (D=*2002.09)				4					N
5-2	1	119802-13820	BOLT, M8X100 9.8T (D=*2009.12)				4					N
6	1	26216-080222	STUD, M8X 22				3					
6-1	1	129418-18320	STUD, M8X20 (D=E01513)				3					N

Remarks
(G) THESE PARTS ARE SOLD BY
FIG.59,REF.NO.1.

Fig.45. CAMSHAFT & DRIVING GEAR

(A)=3TNE84-AGD
(B)=3TNE88-AGD
(C)=4TNE88-AGD

(D)=4TNE84T-AGD
(E)=
(F)=

Y00B5190
3, 4TNE84, 88 (T) -AGD

45 カムシャフト & クドウギヤ
CAMSHAFT & DRIVING GEAR

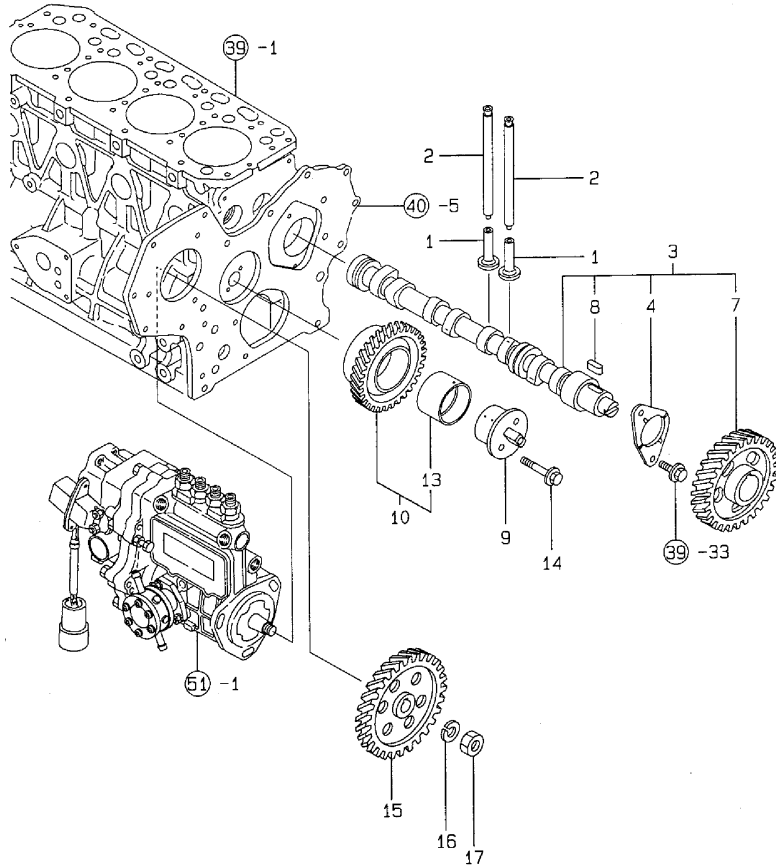

No.	Lev.	Parts No.	Description	Q'ty						I	R	
				(A)	(B)	(C)	(D)	(E)	(F)			
1	1	129150-14200	TAPPET				8					
2	1	129150-14400	ROD, PUSH L=178				8					
3	1	729402-14580	CAMSHAFT ASSY				1					
4	2	129150-02450	BEARING, THRUST				1					
7	2	129150-14101	GEAR, CAMSHAFT				1					
8	2	22512-070140	KEY, 7X 14				1					
9	1	129100-25061	SHAFT, IDLE				1					
10	1	129150-25101	GEAR ASSY, IDLE				1					
13	2	129150-25920	BUSH, IDLE GEAR				1					1
14	1	26106-080452	BOLT, M8X 45 PLATED				2					
15	1	129150-25900	GEAR, PUMP				1					
16	1	22217-120000	WASHER, SPRING 12				1					
17	1	26716-120002	NUT, M12				1					

Remarks
(1) REPAIR PART.

Fig.46. TURBOCHARGER

(A)=3TNE84-AGD
(B)=3TNE88-AGD
(C)=4TNE88-AGD

(D)=4TNE84T-AGD
(E)=
(F)=

Y00B5190
3, 4TNE84, 88 (T) -AGD

46 タービン
TURBOCHARGER

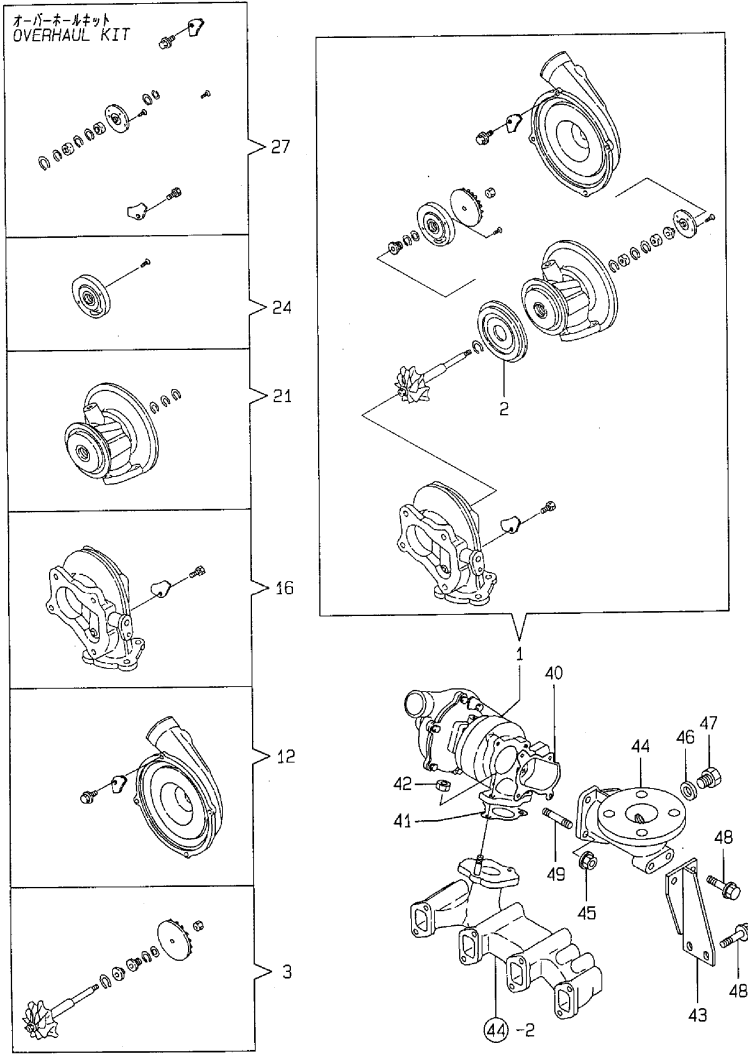

No.	Lev.	Parts No.	Description	Q'ty						I	R
				(A)	(B)	(C)	(D)	(E)	(F)		
1	1	129406-18010	TURBINE, RHB31				1				
2	2	129403-18720	PROTECTOR, HEAT				1				
3	2	129406-18770	ROTOR ASSY				1				
12	2	129406-18780	HOUSING ASSY				1				
16	2	129406-18790	HOUSING ASSY				1				
21	2	129403-18800	HOUSING ASSY				1				
24	2	129406-18820	PLATE ASSY, SEAL				1				
27	2	129406-18830	OVERHALL KIT				1				
40	1	129403-18091	GASKET				1				G
41	1	129477-18101	GASKET				1				G
42	1	194990-22050	NUT, M8				3				
43	1	129412-18290	SUPPORT				1				
44	1	129412-18380	BEND, EXHAUST				1				
45	1	194990-22050	NUT, M8				4				
46	1	23414-170000	GASKET, 17X1.0				1				G
47	1	23894-030002	PLUG, G3/8				1				
48	1	26106-080142	BOLT, M8X 14 PLATED				4				
49	1	26216-080222	STUD, M8X 22				4				

Remarks
(G) THESE PARTS ARE SOLD BY
FIG.59,REF.NO.1.

Fig.47. CRANKSHAFT & PISTON

(A)=3TNE84-AGD
(B)=3TNE88-AGD
(C)=4TNE88-AGD

(D)=4TNE84T-AGD
(E)=
(F)=

Y00B5190
3, 4TNE84, 88 (T) -AGD

47 クラクシャフト & ピストン
CRANKSHAFT & PISTON

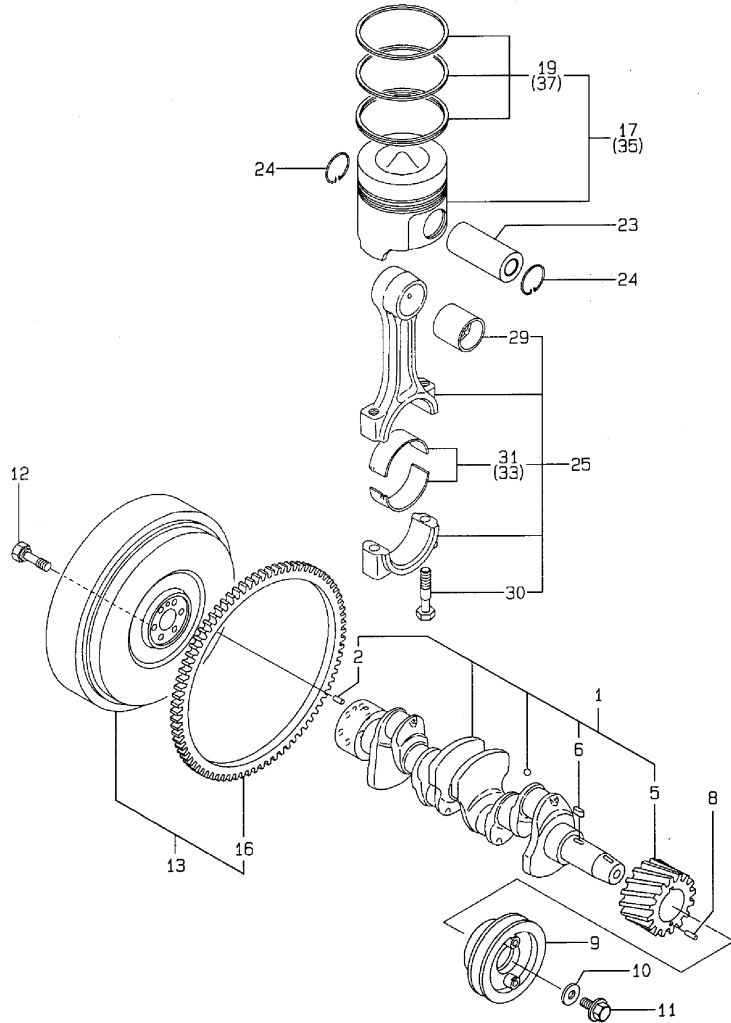

No.	Lev.	Parts No.	Description	Q'ty						I	R	
				(A)	(B)	(C)	(D)	(E)	(F)			
1	1	129407-21000	CRANKSHAFT ASSY				1					
2	2	129100-01580	PIN, M8X16				1					
5	2	129150-21200	GEAR, CRANKSHAFT				1					
6	2	22512-070140	KEY, 7X 14				1					
8	1	22351-040010	PIN, SPRING 4.0X10				1					
9	1	129550-21650	V-PULLEY				1					
10	1	129795-21661	WASHER				1					
11	1	121850-21680	BOLT				1					
12	1	121111-21501	BOLT, FLYWHEEL				6					
13	1	171420-21590	FLYWHEEL ASSY				1					
16	2	124550-21600	GEAR, RING				1					
17	1	129002-22090	PISTON ASSY				4					
19	2	129002-22510	RING SET, PISTON				4					
23	1	129202-22300	PIN, PISTON D26 L70				4					
24	1	22252-000260	RING, 26				8					
25	1	729402-23100	ROD ASSY, CONNECTING				4					
29	2	129100-23910	BEARING, PISTON PIN				4					1
30	2	121550-23200	BOLT, CONNECTING ROD				8					
31	2	129150-23600	BEARING, CRANK PIN				4					
33	1	129150-23610	BEARING, 0.25 US				4					2
35	1	129002-22900	PISTON ASSY, 0.25 OS				4					3
37	2	129002-22950	RING SET, 0.25 OS				4					3

Remarks

- (1)REPAIR PART.
- (2)UNDER-SIZED(U.S=0.25)PART.
- (3)OVER-SIZED(O.S=0.25)PART.

Fig.48. LUB.OIL SYSTEM

(A)=3TNE84-AGD
(B)=3TNE88-AGD
(C)=4TNE88-AGD

(D)=4TNE84T-AGD
(E)=
(F)=

Y00B5190
3, 4TNE84, 88 (T) -AGD

48 LOシステム
LUB.OIL SYSTEM

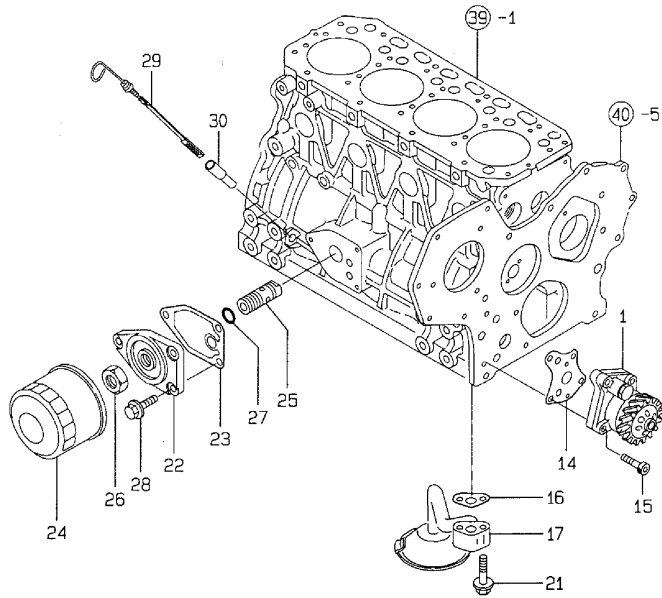

No.	Lev.	Parts No.	Description	Q'ty						I	R	
				(A)	(B)	(C)	(D)	(E)	(F)			
1	1	129407-32000	PUMP ASSY, OIL				1					
14	1	129150-32020	GASKET, PUMP				1					G
15	1	26450-060252	BOLT, M6X 25				4					
16	1	129150-35041	GASKET				1					G
17	1	129436-35090	PIPE ASSY, OIL INLET				1					
21	1	26106-080352	BOLT, M8X 35 PLATED				2					
22	1	129150-35101	BRACKET, STRAINER				1					
23	1	129150-35111	GASKET				1					G
24	1	129150-35151	FILTER, D80XL80				1					
25	1	129001-35300	BOLT, FILTER				1					
26	1	129150-35350	NUT				1					
27	1	24311-000160	O-RING, 1AP16.0				1					G
28	1	26106-080202	BOLT, M8X 20 PLATED				3					
29	1	129136-34800	DIPSTICK, OIL				1					
30	1	121520-34810	GUIDE, DIPSTICK				1					

Remarks
(G) THESE PARTS ARE SOLD BY
FIG.59,REF.NO.1.

Fig.49. LUB.OIL LINE

(A)=3TNE84-AGD
(B)=3TNE88-AGD
(C)=4TNE88-AGD

(D)=4TNE84T-AGD
(E)=
(F)=

Y00B5190
3, 4TNE84, 88 (T) -AGD

49 LOオイル
LUB.OIL LINE

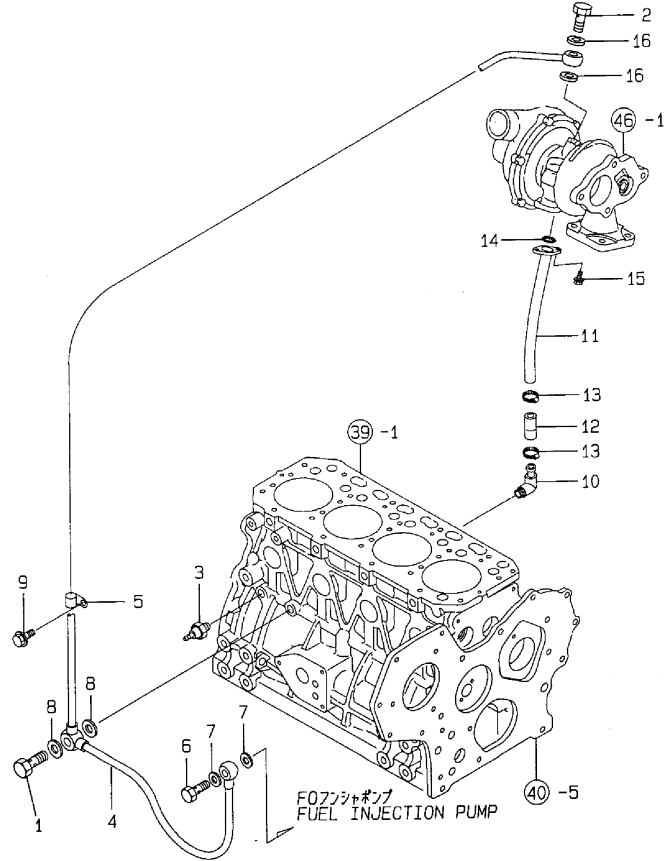

No.	Lev.	Parts No.	Description	Q'ty						I	R
				(A)	(B)	(C)	(D)	(E)	(F)		
1	1	124160-39140	BOLT, PIPE JOINT M10				1				
2	1	105010-39140	BOLT, PIPE JOINT				1				
3	1	124160-39450	SWITCH, 0.5KG				1				
4	1	129403-39450	PIPE ASSY, OIL				1				
5	1	124223-39900	RETAINER				1				
6	1	124550-59820	BOLT, PIPE JOINT M8				1				
7	1	22190-080002	WASHER, SEAL 6				2				G
8	1	23414-100000	GASKET, 10X1.0				2				G
9	1	26106-080102	BOLT, M8X 10 PLATED				1				
10	1	128270-13620	JOINT, PIPE PT3/8				1				
11	1	129403-39600	PIPE, OIL				1				
12	1	129403-39610	JOINT, RUBBER				1				
13	1	23000-022000	CLAMP, 22				2				
14	1	24314-000160	O-RING, 4CP16.0				1				
15	1	26106-060162	BOLT, M6X 16 PLATED				2				
16	1	23414-080000	GASKET, 8X1.0				2				

Remarks
(G) THESE PARTS ARE SOLD BY
FIG.59,REF.NO.1.

Fig.50. COOLING WATER SYSTEM

(A)=3TNE84-AGD
(B)=3TNE88-AGD
(C)=4TNE88-AGD

(D)=4TNE84T-AGD
(E)=
(F)=

Y00B5190
3, 4TNE84, 88 (T) -AGD

50 C/Wシステム
COOLING WATER SYSTEM

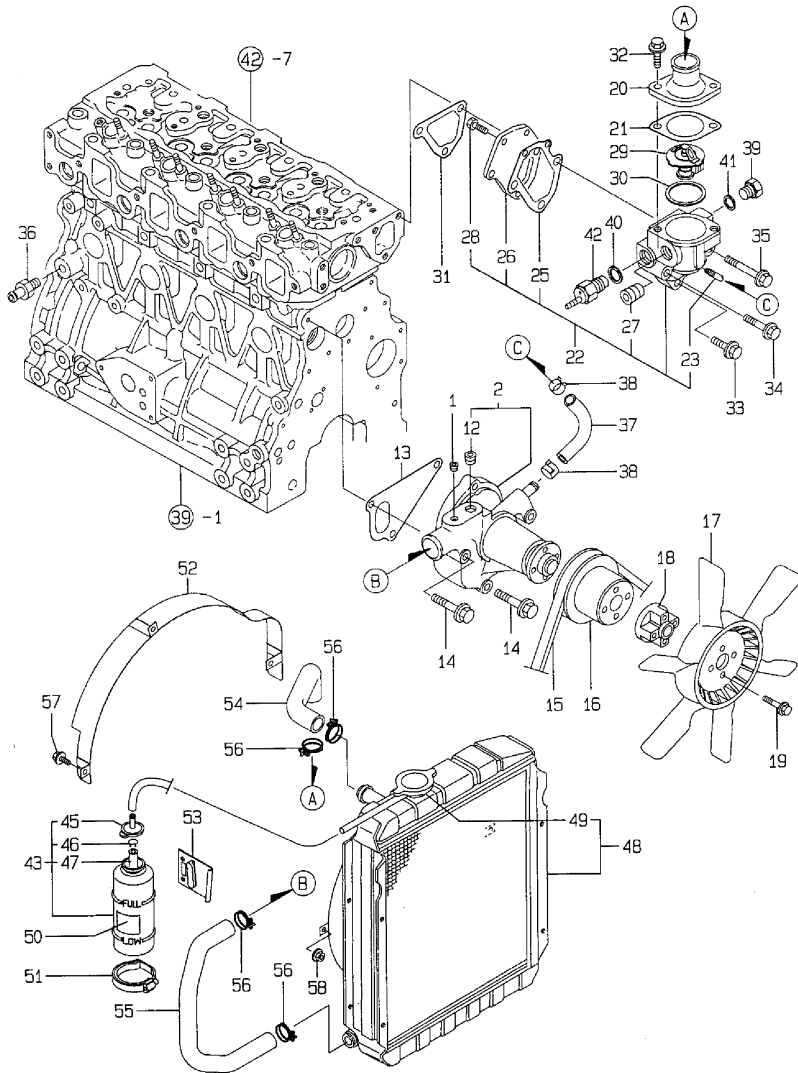

No.	Lev.	Parts No.	Description	Q'ty						I	R
				(A)	(B)	(C)	(D)	(E)	(F)		
1	1	121850-11860	PLUG, PT1/4				1				
2	1	129100-42002	PUMP ASSY, WATER				1				
12	2	23871-030000	PLUG, R03				1				
13	1	129100-42020	GASKET, WATER PUMP				1				G
14	1	26106-080602	BOLT, M8X 60 PLATED				3				
15	1	124732-42290	V-BELT, AX37				1				
16	1	129155-42350	V-PULLEY				1				
17	1	129432-44740	FAN, COOLING D370XEF				1				
18	1	171353-44760	SPACER, FAN				1				
19	1	26106-060352	BOLT, M6X 35 PLATED				4				
20	1	129350-49530	COVER, THERMOSTAT				1				
21	1	129795-49551	GASKET				1				G
22	1	129100-49800	CASE ASSY, THERMOSTAT				1				
23	2	124770-11770	JOINT, PIPE PT1/8				1				
25	2	129100-49820	GASKET				1				
26	2	129100-49830	COVER, THERMOSTAT				1				
27	2	23871-030000	PLUG, R03				1				
28	2	26116-060162	BOLT, M6X 16 PLATED				2				
29	1	129155-49800	THERMOSTAT, 71				1				
30	1	129150-49811	GASKET, THERMOSTAT				1				G
31	1	129100-49840	GASKET				1				G
32	1	26106-080202	BOLT, M8X 20 PLATED				2				
33	1	26106-080252	BOLT, M8X 25 PLATED				1				
34	1	26106-080502	BOLT, M8X 50 PLATED				1				
35	1	26106-080602	BOLT, M8X 60 PLATED				1				
36	1	121550-49111	JOINT, PT1/4				1				
37	1	129132-49050	PIPE, WATER				1				
38	1	23000-016000	CLAMP, 16				2				
39	1	121450-42450	PLUG, M16				1				
40	1	124465-44950	GASKET, 16				1				G
41	1	124465-44950	GASKET, 16				1				G
42	1	121250-44901	SWITCH, 110				1				
43	1	124450-44510	TANK ASSY, SUB				1				
45	2	124450-44530	CAP				1				
46	2	124450-44560	RETAINER				1				
47	2	23061-070230	PIPE, 7X 230				1				
48	1	129411-44510	RADIATOR				1				
49	2	124450-44590	CAP, RADIATOR				1				
50	1	121470-44540	LABEL, SUB-TANK				1				
51	1	124450-44550	BAND				1				
52	1	129411-44560	PROTECTOR, FAN				1				
53	1	121256-44600	BRACKET, SUB TANK				1				
54	1	171420-49010	PIPE, WATER				1				
55	1	171420-49020	PIPE, WATER				1				
56	1	23010-038000	CLAMP, 38				4				
57	1	26014-080202	BOLT, M8X 20				3				
58	1	26366-080002	NUT, M8				3				

Remarks
(G) THESE PARTS ARE SOLD BY
FIG.59, REF.NO.1.

Fig.51. FUEL INJECTION PUMP

(A)=3TNE84-AGD
(B)=3TNE88-AGD
(C)=4TNE88-AGD

(D)=4TNE84T-AGD
(E)=
(F)=

Y00B5190
3, 4TNE84, 88 (T) -AGD

51 F07アンシャポンプ
FUEL INJECTION PUMP

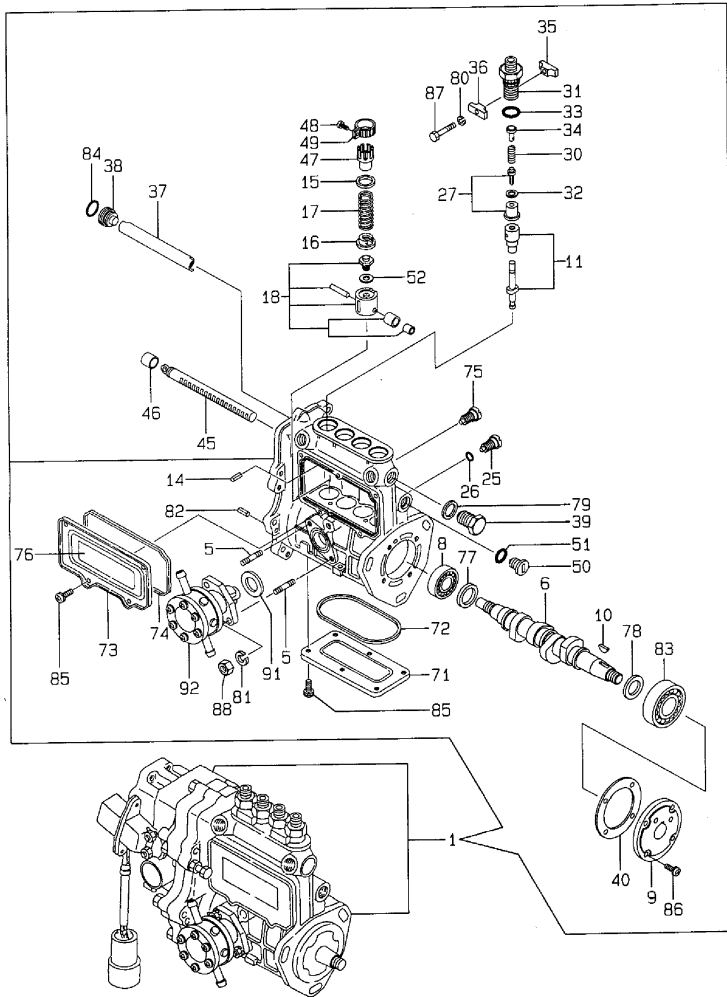

No.	Lev.	Parts No.	Description	Q'ty						I	R
				(A)	(B)	(C)	(D)	(E)	(F)		
1	1	729611-51200	PUMP ASSY, INJECTION				1				1
5	2	129155-51020	STUD				2				
6	2	129506-51040	CAMSHAFT				1				
8	2	129155-51050	BEARING, 17BM001D				1				
9	2	129155-51060	SUPPORT, CAMSHAFT				1				
10	2	122710-51090	KEY				1				
11	2	129506-51100	PLUNGER ASSY				4				
14	2	129155-51140	PIN				4				
15	2	174307-51170	RETAINER, SPRING A				4				
16	2	129155-51180	RETAINER, SPRING				4				
17	2	124950-51190	SPRING, PLUNGER				4				
18	2	129155-51200	TAPPET ASSY				4				
25	2	129155-51270	STOPPER, TAPPET				4				
26	2	129155-51280	O-RING, S6				4				
27	2	129100-51300	VALVE ASSY, DELIVERY				4				
30	2	129155-51320	SPRING, DELIVERY				4				
31	2	129155-51340	RETAINER				4				
32	2	124550-51350	GASKET, DELIVERY				4				
33	2	124550-51370	O-RING				4				
34	2	129155-51370	STOPPER, VALVE				4				
35	2	129155-51380	STOPPER				2				
36	2	129155-51390	STOPPER				2				
37	2	129555-51400	DEFLECTOR				1				
38	2	129155-51410	BOLT				1				
39	2	129155-51420	PLUG, M16				1				
40	2	129155-51450	SHIM SET, ADJUSTING				1				
45	2	129555-51500	RACK, CONTROL				1				
46	2	129155-51521	BUSH, RACK				1				
47	2	129155-51550	PINION, CONTROL				4				
48	2	122117-51560	SCREW				4				
49	2	174307-51560	PINION				4				
50	2	129155-51570	PLUG, M12				1				
51	2	129155-51580	O-RING				1				
52	2	129155-51600	SHIM SET, ADJUSTING				4				
71	2	129555-51700	COVER				1				
72	2	129555-51710	GASKET				1				
73	2	129555-51750	COVER				1				
74	2	129555-51760	GASKET				1				
75	2	129155-51790	STOOPER, RACK				1				
76	2	129156-51910	LABEL, CAUTION				1				
77	2	129155-51930	SPACER, T=3.25				1				
78	2	129155-51940	SPACER, T=1.5				1				
79	2	22190-160002	WASHER, SEAL 16				1				
80	2	22217-050000	WASHER, SPRING 5				2				
81	2	22217-060000	WASHER, SPRING 6				2				
82	2	22351-050010	PIN, SPRING 5.0X10				2				
83	2	24101-063034	BEARING, BALL 6303				1				
84	2	24341-000160	O-RING, 1AS16.0				1				
85	2	26022-050102	SCREW, M5X10				11				
86	2	26022-060162	SCREW, M6X16				4				
87	2	26116-050302	BOLT, M5X 30 PLATED				2				

Remarks

(1) GOVERNOR ASSY(FIG.NO.52) IS INCORPORATED IN THIS FUEL INJECTION PUMP ASSY(REF.NO.1).
(G) THESE PARTS ARE SOLD BY FIG.59, REF.NO.1.

Fig.51. FUEL INJECTION PUMP

(A)=3TNE84-AGD
 (B)=3TNE88-AGD
 (C)=4TNE88-AGD

(D)=4TNE84T-AGD
 (E)=
 (F)=

Y00B5190
 3, 4TNE84, 88 (T) -AGD

51 F07ンシャポンプ
 FUEL INJECTION PUMP

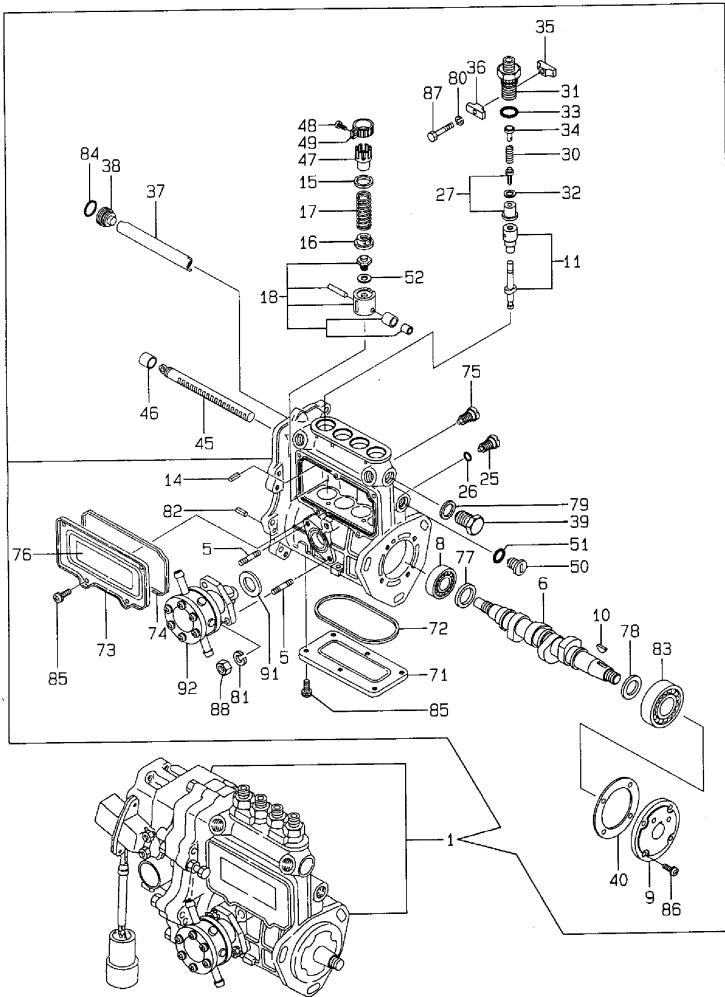

No.	Lev.	Parts No.	Description	Q'ty						I	R
				(A)	(B)	(C)	(D)	(E)	(F)		
88	2	26716-060002	NUT, M6				2				
91	2	129155-52050	GASKET				1				G
92	2	129100-52100	PUMP ASSY, FUEL FEED				1				

Remarks

(1) GOVERNOR ASSY(FIG.NO.52) IS INCORPORATED IN THIS FUEL INJECTION PUMP ASSY(REF.NO.1).
 (G) THESE PARTS ARE SOLD BY FIG.59, REF.NO.1.

Fig.52. GOVERNOR

(A)=3TNE84-AGD
(B)=3TNE88-AGD
(C)=4TNE88-AGD

(D)=4TNE84T-AGD
(E)=
(F)=

Y00B5190
3, 4TNE84, 88 (T) -AGD

52 ガバネ
GOVERNOR

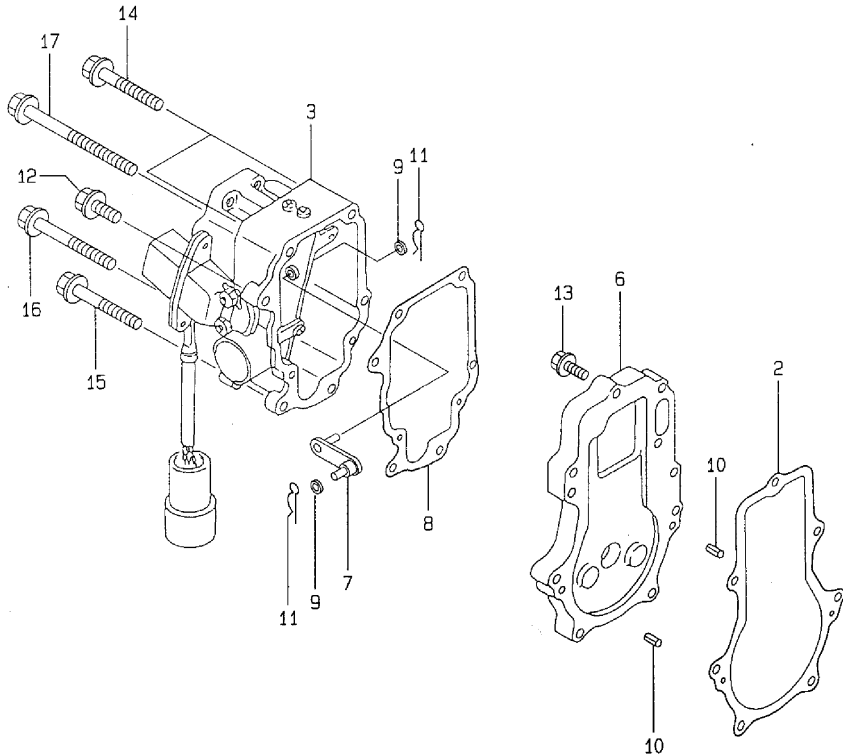

No.	Lev.	Parts No.	Description	Q'ty						I	R	
				(A)	(B)	(C)	(D)	(E)	(F)			
2	2	129116-61051	GASKET				1					
3	2	119649-61100	ACTUATOR				1					
6	2	129116-61110	SPACER				1					
7	2	129116-61120	LINK				1					
8	2	119649-61151	GASKET				1					
9	2	22117-040000	WASHER, 4				2					
10	2	22351-040010	PIN, SPRING 4.0X10				2					
11	2	22360-050000	SNAP PIN 5				2					
12	2	26106-060202	BOLT, M6X 20 PLATED				1					
13	2	26106-060222	BOLT, M6X 22 PLATED				7					
14	2	26106-060452	BOLT, M6X 45 PLATED				2					
15	2	26106-060602	BOLT, M6X 60 PLATED				1					
16	2	26106-060702	BOLT, M6X 70 PLATED				1					
17	2	26106-060852	BOLT, M6X 85 PLATED				1					

Fig.53. FUEL INJECTION VALVE

(A)=3TNE84-AGD
(B)=3TNE88-AGD
(C)=4TNE88-AGD

(D)=4TNE84T-AGD
(E)=
(F)=

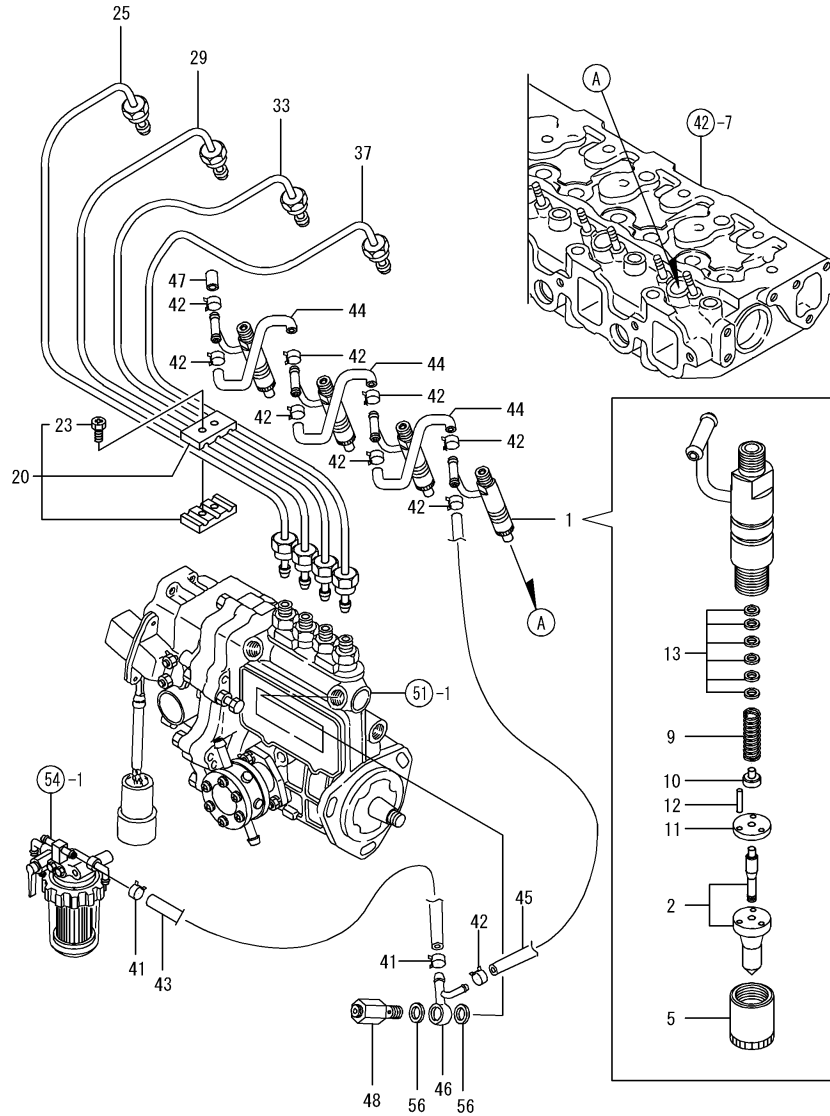

No.	Lev.	Parts No.	Description	Qty						I	R	
				(A)	(B)	(C)	(D)	(E)	(F)			
1	1	729503-53100	VALVE ASSY,INJECTION				4					
2	2	129503-53000	VALVE ASSY,INJECTION				4					
5	2	114250-53080	NUT, NOZZLE D16.95				4					
9	2	114250-53120	SPRING, NOZZLE				4					
10	2	114250-53130	SEAT, SPRING				4					
11	2	114250-53140	PLATE				4					
12	2	114250-53210	PIN				8					
13	2	114250-53400	SHIM SET				4					
20	1	129150-59120	RETAINER, PIPE				2					
23	2	129150-59131	BOLT, M4X14				4					
25	1	129400-59910	PIPE ASSY, INJECTION				1					
29	1	129400-59920	PIPE ASSY, INJECTION				1					
33	1	129400-59930	PIPE ASSY, INJECTION				1					
37	1	129400-59940	PIPE ASSY, INJECTION				1					
41	1	124766-59050	CLIP, HOSE 12				2					
42	1	124066-59100	CLIP, HOSE 8				9					
43	1	105025-59530	PIPE, FUEL D13X400				1					
44	1	121250-59550	PIPE, FUEL D8X120				3					
45	1	119840-59560	PIPE, FUEL RETURN				1					
46	1	119840-59570	JOINT				1					
47	1	129150-59580	CAP				1					
48	1	129100-59951	VALVE ASSY, CHECK				1					
56	1	23414-120000	GASKET, 12X1.0				2					G

Remarks
(G) THESE PARTS ARE SOLD BY
FIG.59,REF.NO.1.

Fig.54. FUEL LINE

(A)=3TNE84-AGD
(B)=3TNE88-AGD
(C)=4TNE88-AGD

(D)=4TNE84T-AGD
(E)=
(F)=

Y00B5190
3, 4TNE84, 88 (7) -AGD

54 FUEL LINE

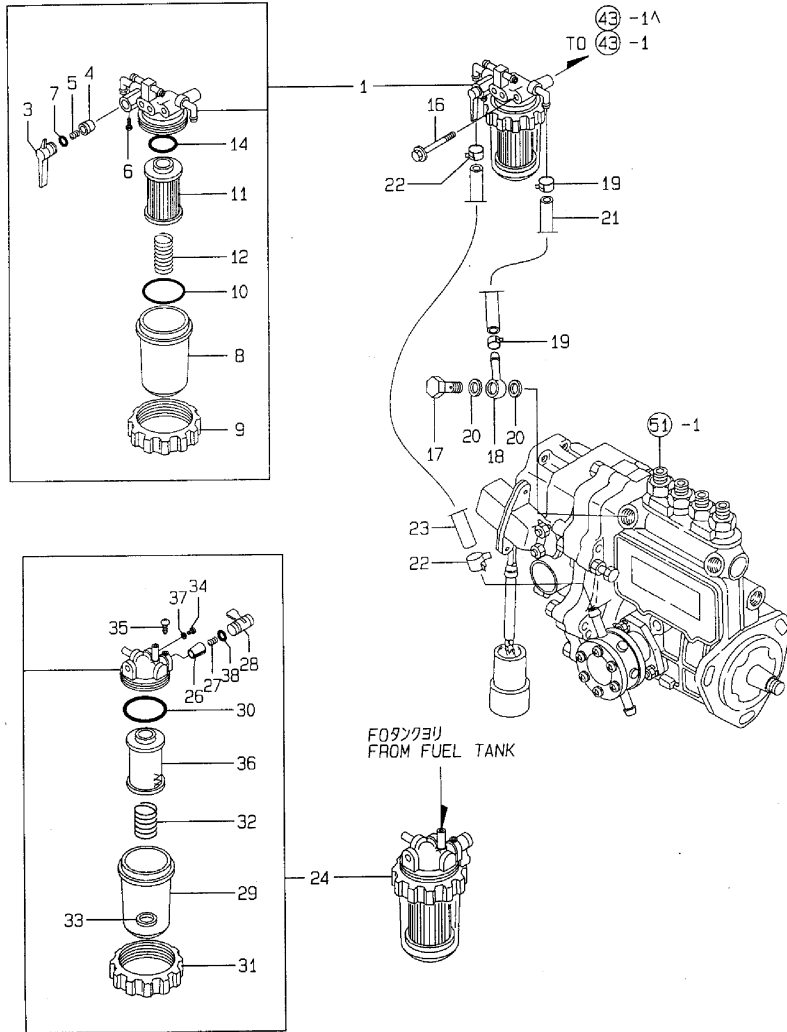

No.	Lev.	Parts No.	Description	Qty						I	R	
				(A)	(B)	(C)	(D)	(E)	(F)			
1	1	129052-55620	FILTER ASSY, FUEL				1					
3	2	129100-55670	LEVER				1					
4	2	104200-55321	VALVE, TAPER				1					
5	2	104200-55330	SPRING, VALVE				1					
6	2	104200-55750	SCREW, M4				1					
7	2	24311-240100	O-RING, 1AP10A				1					
8	2	129100-55680	CUP, STRAINER				1					
9	2	129100-55690	RING, RETAINING				1					
10	2	24321-000650	O-RING, 1AG65.0				1					G
11	2	129100-55650	ELEMENT				1					
12	2	129100-55700	SPRING				1					
14	2	24311-000160	O-RING, 1AP16.0				1					
16	1	26014-080702	BOLT, M8X 70				1					
17	1	103854-39140	BOLT, PIPE JOINT				1					
18	1	101304-59020	JOINT, PIPE 12				1					
19	1	124766-59050	CLIP, HOSE 12				2					
20	1	104200-59170	GASKET, 12				2					G
21	1	105312-59510	PIPE, FUEL				1					
22	1	124766-59050	CLIP, HOSE 12				2					
23	1	105025-59530	PIPE, FUEL D13X400				1					
24	1	121257-55700	SEPARATOR, WATER				1					
26	2	104200-55321	VALVE, TAPER				1					
27	2	104200-55330	SPRING, VALVE				1					
28	2	104200-55341	HANDLE				1					
29	2	121254-55510	COVER				1					
30	2	102103-55520	O-RING				1					
31	2	110250-55610	RING, RETAINING				1					
32	2	121257-55720	SPRING				1					
33	2	121257-55731	FLOAT				1					
34	2	101720-55750	PLUG, 6				2					
35	2	104200-55750	SCREW, M4				1					
36	2	171081-55910	SCREEN				1					
37	2	23418-060000	GASKET, 6X1.0				2					
38	2	24311-240100	O-RING, 1AP10A				1					

Remarks
(G) THESE PARTS ARE SOLD BY
FIG.59,REF.NO.1.

Fig.55. STARTING MOTOR

(A)=3TNE84-AGD
(B)=3TNE88-AGD
(C)=4TNE88-AGD

(D)=4TNE84T-AGD
(E)=
(F)=

Y00B5190
3, 4TNE84, 88 (T) -AGD

55 スターティングモータ
STARTING MOTOR

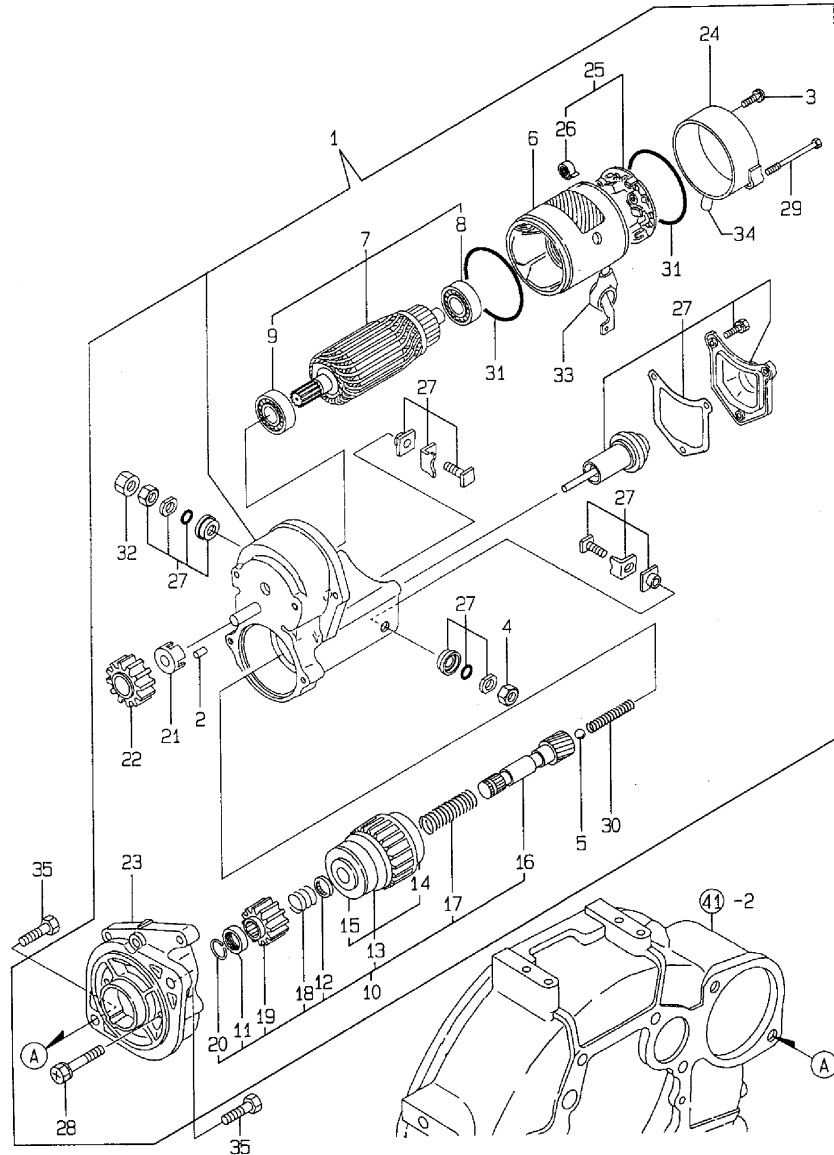

No.	Lev.	Parts No.	Description	Qty						I	R
				(A)	(B)	(C)	(D)	(E)	(F)		
1	1	129407-77010	STARTER, RA1.4				1				
2	2	X0283060061	ROLLER				5				
3	2	X0289030010	SCREW				2				
4	2	X9490561370	NUT				1				
5	2	X9491200240	BALL				1				
6	2	129407-77210	YOKE ASSY				1				
7	2	129407-77220	ARMATURE ASSY				1				
8	3	129129-77230	BEARING				1				
9	3	129129-77240	BEARING				1				
10	2	129407-77250	STARTER				1				
11	3	X0280210230	NUT				1				
12	3	X0283270140	RETAINER				1				
13	3	129407-77390	CLUTCH ASSY				1				
14	4	129129-77440	BEARING, BALL				1				
15	4	129129-77450	BEARING, BALL				1				
16	3	129129-77400	SHAFT				1				
17	3	129129-77410	SPRING, COIL				1				
18	3	129407-77410	SPRING				1				
19	3	129129-77420	PINION, STARTER				1				
20	3	129129-77430	RING				1				
21	2	129129-77260	RETAINER				1				
22	2	129129-77270	PINION				1				
23	2	129407-77280	HOUSING				1				
24	2	129129-77290	FRAME				1				
25	2	129407-77300	HOLDER ASSY				1				
26	3	X9491730461	SPRING				4				
27	2	129407-77310	SWITCH ASSY				1				
28	2	129129-77320	BOLT				2				
29	2	129407-77330	BOLT				2				
30	2	129129-77340	SPRING				1				
31	2	129129-77350	O-RING				2				
32	2	129129-77370	NUT				1				
33	2	129129-77380	CAP				1				
34	2	129129-77361	BUSH				1				
35	1	26116-120252	BOLT, M12X 25 PLATED				2				

Fig.56. GENERATOR

(A)=3TNE84-AGD
(B)=3TNE88-AGD
(C)=4TNE88-AGD

(D)=4TNE84T-AGD
(E)=
(F)=

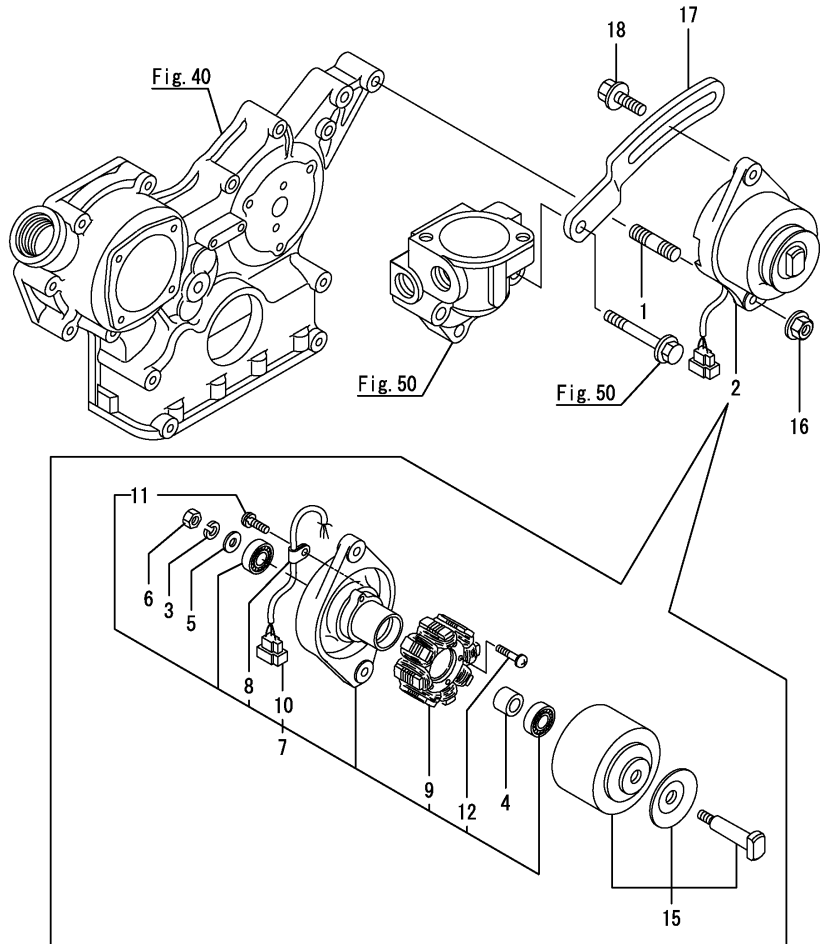

No.	Lev.	Parts No.	Description	Q'ty						I	R	
				(A)	(B)	(C)	(D)	(E)	(F)			
1	1	121450-01570	BOLT, STUD							1		
2	1	129150-77202	GENERATOR							1		
2-1	1	129150-77203	DINAMO ASSY							1		N
			(D=EXXXXX)									
3	2	XM219230000	WASHER, SPRING							1		
4	2	XM329830000	COLLAR							1		
5	2	XM860250000	WASHER, 10							1		
6	2	XM863720000	NUT							1		
7	2	129150-77210	PLATE ASSY							1		
8	3	XM069000000	CLAMP							1		
9	3	XM081780000	STATOR							1		
10	3	XM178780000	COUPLER							1		
11	3	XYSPS400800	SCREW							1		
12	3	XYSPS402400	SCREW							2		
15	2	129150-77230	FLYWHEEL ASSY							1		
15-1	2	129150-77280	FLYWHEEL ASSY							1		N
			(D=EXXXXX)									
16	1	26366-100002	NUT, M10							1		
17	1	129410-77330	ADJUSTER, BELT							1		
18	1	26014-080252	BOLT, M8X 25							1		

Fig.57. PULSER

(A)=3TNE84-AGD
 (B)=3TNE88-AGD
 (C)=4TNE88-AGD

(D)=4TNE84T-AGD
 (E)=
 (F)=

No.	Lev.	Parts No.	Description	Q'ty						I	R
				(A)	(B)	(C)	(D)	(E)	(F)		
1	1	172010-08160	STICKER, WIRE				1				
2	1	194180-51640	CLAMP, HARNESS				1				
3	1	119649-78500	PULSAR				1				
4	1	129116-78510	BRACKET, PULSAR				1				
5	1	22351-040010	PIN, SPRING 4.0X10				1				
6	1	26116-060122	BOLT, M6X 12 PLATED				2				
7	1	26557-040082	SCREW, M4X 8				2				
8	1	119649-78650	GEAR, PULSAR				1				
9	1	26106-100142	BOLT, M10X 14 PLATED				2				
10	1	129111-78802	CONTROLLER, MAIN 4P				1				

Y0085190
 3, 4TNE84, 88 (T) -AGD

57 パルサー
 PULSER

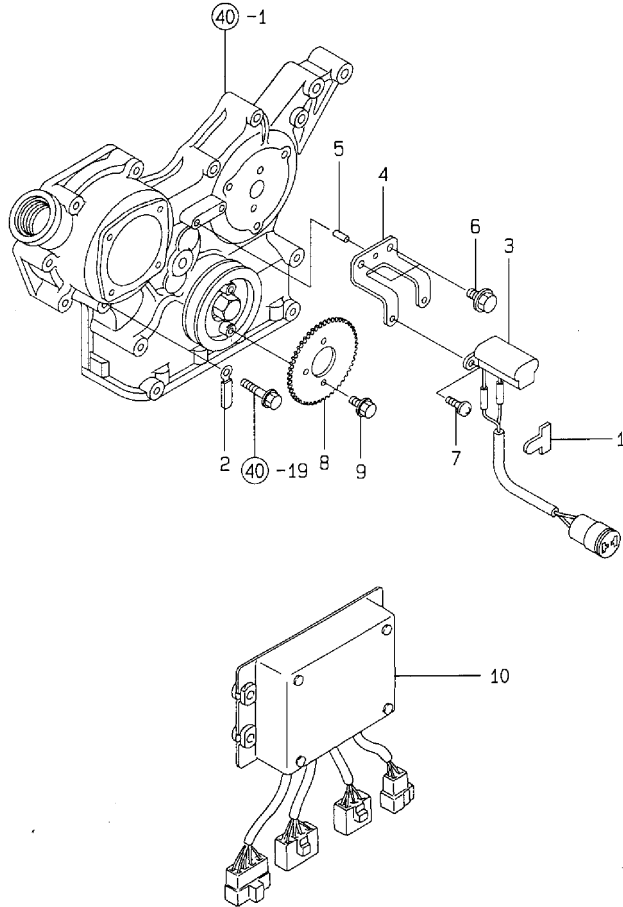

Fig.58. ELECTRIC PARTS

(A)=3TNE84-AGD
(B)=3TNE88-AGD
(C)=4TNE88-AGD

(D)=4TNE84T-AGD
(E)=
(F)=

Y0085190
3, 4TNE84, 88 (T) -AGD

58 デンソウヒン
ELECTRIC PARTS

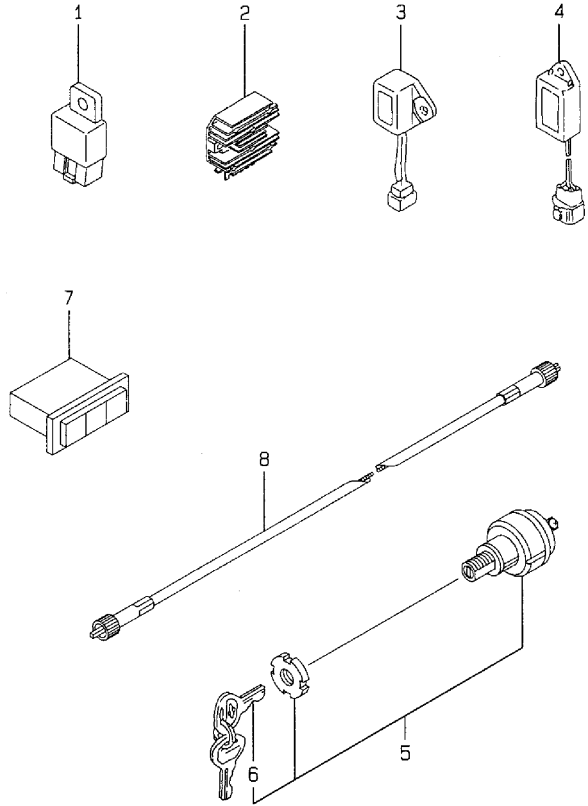

No.	Lev.	Parts No.	Description	Q'ty						I	R	
				(A)	(B)	(C)	(D)	(E)	(F)			
1	1	119247-77100	RELAY, SAFETY				1					
2	1	119640-77711	LIMITER, CURRENT				1					
3	1	121522-77721	INDICATOR				1					
4	1	128300-77920	TIMER				1					
5	1	121400-91251	SWITCH, STARTER				1					
6	2	121400-91271	KEY, SWITCH				1					
7	1	129411-91310	LAMP				1					
7A	2	129411-91360	BULB, 12V-3.4W				6					W
8	1	194185-56900	CABLE ASSY, METER				1					

Fig.59. GASKET SET(OPTIONA) & TOOL

(A)=3TNE84-AGD
(B)=3TNE88-AGD
(C)=4TNE88-AGD

(D)=4TNE84T-AGD
(E)=
(F)=

Y00B5190
3. 4TNE84, 88 (T) -AGD

59 パッキンセット (オプション) & コウグ
GASKET SET (OPTIONAL) & TOOL

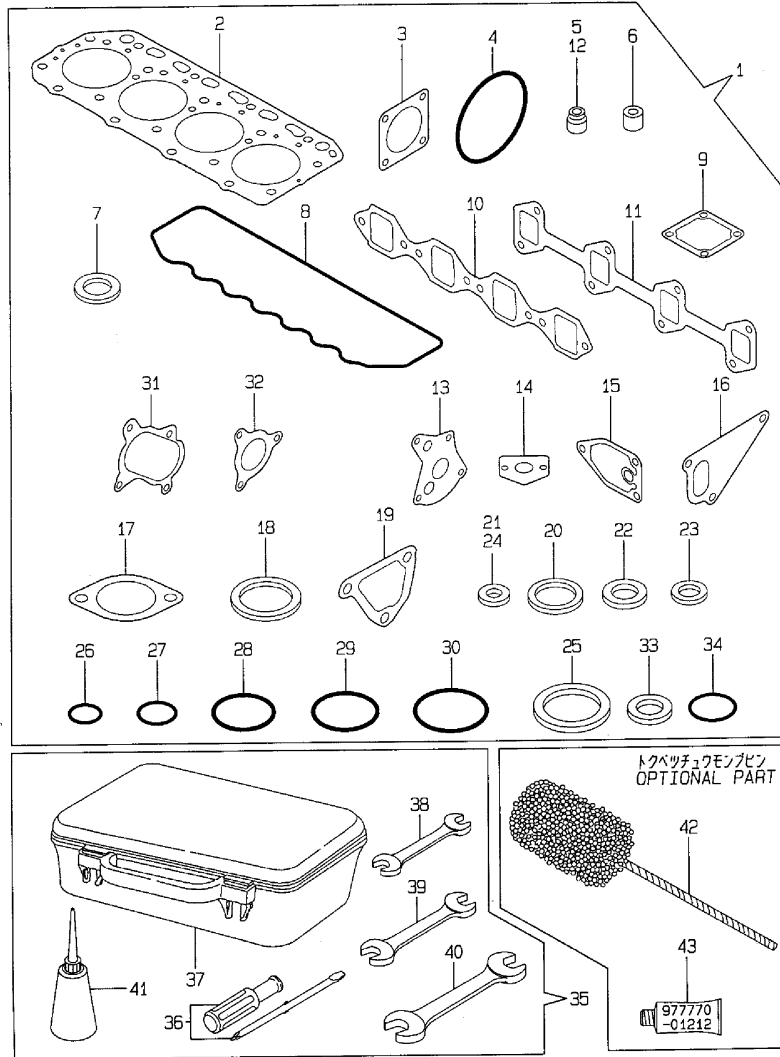

No.	Lev.	Parts No.	Description	Q'ty						I	R
				(A)	(B)	(C)	(D)	(E)	(F)		
1	1	729611-92610	GASKET SET				1				1
2	2	129408-01330	GASKET, HEAD				1				
3	2	124240-01883	GASKET				1				
4	2	121850-51960	O-RING				1				
5	2	124460-11340	SEAL, VALVE STEM				4				
6	2	119625-11871	PROTECTOR, NOZZLE				4				
7	2	119625-11880	SEAT, NOZZLE				4				
8	2	129550-11310	GASKET, BONNET				1				
9	2	129150-77511	GASKET				1				
10	2	129550-12111	GASKET, MANIFOLD				1				
11	2	129550-13110	GASKET				1				
12	2	121400-11340	SEAL, VALVE STEM				4				
13	2	129150-32020	GASKET, PUMP				1				
14	2	129150-35041	GASKET				1				
15	2	129150-35111	GASKET				1				
16	2	129100-42020	GASKET, WATER PUMP				1				
17	2	129795-49551	GASKET				1				
18	2	129150-49811	GASKET, THERMOSTAT				1				
19	2	129100-49840	GASKET				1				
20	2	129155-52050	GASKET				1				
21	2	104200-59170	GASKET, 12				2				
22	2	22190-080002	WASHER, SEAL 6				7				
23	2	23414-100000	GASKET, 10X1.0				2				
24	2	23414-120000	GASKET, 12X1.0				2				
25	2	23414-170000	GASKET, 17X1.0				1				
26	2	24311-000120	O-RING, 1AP12.0				3				
27	2	24311-000160	O-RING, 1AP16.0				3				
28	2	24311-000320	O-RING, 1AP32.0				2				
29	2	24341-000240	O-RING, 1AS24.0				1				
30	2	24341-000500	O-RING, 1AS50.0				1				
31	2	129403-18091	GASKET				1				
32	2	129477-18101	GASKET				1				
33	2	124465-44950	GASKET, 16				2				
34	2	24321-000650	O-RING, 1AG65.0				1				
35	1	171001-93100	BOX, TOOL				1				
36	2	104200-92350	DRIVER, SCREW				1				
37	2	104200-92600	BOX, TOOL				1				
38	2	28110-100120	SPANNER, 10X12				1				
39	2	28110-140170	SPANNER, 14X17				1				
40	2	28110-190220	SPANNER, 19X22				1				
41	2	28210-000140	OILER				1				
42	1	129400-92420	HONE				1				1
43	1	977770-01212	GASKET, LIQUID				1				1

Remarks
(1) OPTIONAL PART.

Parts No. Index

Parts No.	Fig. No.	Ref. No.
101304-59020	14	33
	33	18
	54	18
101720-55750	14	27
	33	33
	54	34
102103-55520	14	23
	33	29
	54	30
103854-39140	14	32
	33	17
	54	17
104200-55321	14	4
		19
	33	4
		25
	54	4
104200-55330	14	5
		20
	33	5
		26
	54	5
104200-55341	14	21
	33	27
	54	28
		27
104200-55750	14	6
		28
	33	6
		34
	54	6
104200-59170		35
	14	35
	19	36
	33	21
	38	22
	54	20
104200-92350	59	21
	19	38
	38	34
	59	36
104200-92600	19	39
	38	35
	59	37
		37
105010-39140	49	2
105025-59530	14	37
	32	56
	33	22
	53	43

Parts No.	Fig. No.	Ref. No.
105025-59530	54	23
105312-59510	54	21
110250-55610	14	24
	33	30
	54	31
114250-53080	13	5
	32	5
	53	5
114250-53120	13	9
	32	9
	53	9
114250-53130	13	10
	32	10
	53	10
114250-53140	13	11
	32	11
	53	11
	13	12
114250-53210	32	12
	53	12
	13	13
114250-53400	32	13
	53	13
	18	1
	37	1
119247-77100	58	1
	13	20
	32	20
119305-59120	3	3
	22	3
	41	3
119620-01750	4	26
	19	29
	23	27
	38	6
	42	33
119625-11871	59	6
	4	27
	19	30
	23	28
119625-11880	38	7
	42	34
	59	7
	4	28
	23	29
119625-11900	42	35
	3	9
	22	9
119640-01640	41	7
	22	9
	41	7
119640-77711	18	2

Parts No.	Fig. No.	Ref. No.
119640-77711	37	2
	58	2
119649-61100	12	3
	31	3
	52	3
	12	8
119649-61151	31	8
	52	8
	17	3
	36	3
119649-78500	57	3
	17	8
	36	8
	57	8
119649-78650	44	3 -1
	44	4 -1
	44	5 -2
	11	7
119802-13650	13	2
119802-13670	32	2
119802-13820	13	39
119810-51040	32	43
119810-53000	53	45
119840-59560	13	40
	32	44
	53	46
119840-59570	4	13
	23	11
	42	14
120130-11860	8	12
	27	12
	47	12
	10	41
121111-21501	29	42
	50	42
	13	38
121250-44901	32	42
	53	44
	14	22
	33	28
121250-59550	54	29
	10	53
	29	53
121254-55510	50	53
	14	17
	33	23
	54	24
121256-44600	14	25
	33	31
	54	32
121257-55700	14	17
	33	23
	54	24
	14	25
121257-55720	33	31
	54	32

Parts No.	Fig. No.	Ref. No.
121257-55731	14	26
	33	32
	54	33
121400-11340	4	23
	19	27
	23	22
	38	13
121400-91251	42	28
	59	12
	18	5
	37	5
121400-91271	58	5
	18	6
	37	6
	58	6
121450-01560	2	6
	21	6
	40	6
121450-01570	16	1
	35	1
	56	1
	10	39
121450-42450	29	39
	50	39
	10	50
121470-44540	29	50
	50	50
	9	17
121520-34810	28	39
	48	30
	18	3
121522-77721	37	3
	58	3
	8	36
121550-23200	27	30
	47	30
	10	36
121550-49111	29	36
	50	36
	10	1
	29	1
121850-11860	42	18
	50	1
	8	11
121850-21680	27	11
	47	11
	2	12
121850-51960	19	6
	21	12
	38	4

Parts No. Index

Parts No.	Fig. No.	Ref. No.
121850-51960	40	12
	59	4
122117-51560	11	49
	30	48
	51	48
122710-51090	11	11
	30	10
	51	10
124066-59100	13	37
	32	41
	53	42
124160-01751	2	7
	4	47
	21	7
	23	46
	40	7
	42	52
124160-01910	1	9
	20	5
		6
	39	5
		6
124160-11360	4	50
	23	56
	42	62
124160-39140	9	28
	28	30
	49	1
124160-39450	9	33
	28	29
	49	3
124223-39900	49	5
124240-01871	2	8
	21	8
	40	8
124240-01883	2	9
	19	5
	21	9
	38	3
	40	9
	59	3
124450-21600	27	16
124450-44510	10	45
	29	43
	50	43
124450-44530	10	47
	29	45
	50	45
124450-44550	10	51
	29	51

Parts No.	Fig. No.	Ref. No.
124450-44550	50	51
124450-44560	10	48
	29	46
	50	46
124450-44590	10	44
	29	49
	50	49
124460-11340	4	24
	19	28
	23	23
	38	5
	42	29
	59	5
124465-44950	10	40
		42
	19	21
	29	40
		41
	38	25
	50	40
		41
	59	33
124550-21600	8	16
	47	16
124550-51350	11	33
	30	32
	51	32
124550-51370	11	34
	30	33
	51	33
124550-59820	9	34
	28	35
	49	6
124701-11911	6	7
	19	12
124732-42290	10	15
	29	15
	50	15
124736-07900	4	6
	23	5
	42	5
124766-59050	13	51
	14	34
	32	55
	33	19
	53	41
	54	19
		22
124770-11770	10	23
	29	23

Parts No.	Fig. No.	Ref. No.
124770-11770	50	23
124950-51190	11	18
	30	17
	51	17
128270-13620	49	10
128300-77920	18	4
	37	4
	58	4
129001-01340	1	33
	19	4
129001-02800	1	19
	20	16
	39	18
129001-11310	4	46
	19	9
129001-11340	4	48
129001-11350	4	43
129001-11700	4	8
129001-12110	5	1
	19	11
129001-12120	5	2
129001-13100	6	1
129001-13110	6	2
	19	13
129001-21000	8	1
129001-22081	8	23
	27	17
129001-22500	8	25
	27	19
129001-22900	8	45
129001-22901	27	33
129001-22950	8	47
	27	35
129001-32001	9	1
129001-35300	9	24
	28	25
	48	25
129002-01331	1	32
	19	3
129002-22081	8	17
129002-22090	47	17
129002-22500	8	19
129002-22510	47	19
129002-22900	8	39
	47	35
129002-22950	8	41
	47	37
129002-59810	13	25
129002-59820	13	29
129002-59830	13	33

Parts No.	Fig. No.	Ref. No.
129052-55620	14	1
	33	1
	54	1
129100-01580	3	1
		15
	8	2
	22	1
		15
	27	2
	41	1
		15
	47	2
129100-01640	3	16
	22	16
	41	16
129100-01730	3	6
129100-01770	3	8
129100-11100	4	18
	23	17
	42	23
129100-11110	4	19
	23	18
129100-11130	42	24
129100-11240	4	29
129100-11650	4	36
	23	37
	42	43
129100-23910	8	35
	27	29
	47	29
129100-25061	7	10
	26	9
	45	9
129100-35301	9	19
129100-42002	10	2
	29	2
	50	2
129100-42020	10	13
	19	17
	29	13
	38	17
	50	13
	59	16
129100-49800	10	22
	29	22
	50	22
129100-49820	10	25
	29	25
	50	25
129100-49830	10	26

Parts No. Index

Parts No.	Fig. No.	Ref. No.
129100-49830	29	26
	50	26
129100-49840	10	31
	19	20
	29	31
	38	20
	50	31
	59	19
129100-51300	11	28
	30	27
	51	27
129100-52100	11	94
	30	92
	51	92
129100-55650	14	11
	33	11
	54	11
129100-55670	14	3
	33	3
	54	3
129100-55680	14	8
	33	8
	54	8
129100-55690	14	9
	33	9
	54	9
129100-55700	14	12
	33	12
	54	12
129100-59951	13	42
	32	46
	53	48
129111-44590	10	52
129111-78802	17	10
	36	10
	57	10
129116-61051	12	2
	31	2
	52	2
129116-61110	12	6
	31	6
	52	6
129116-61120	12	7
	31	7
	52	7
129116-78510	17	4
	36	4
	57	4
129120-77501	5	6
	24	6

Parts No.	Fig. No.	Ref. No.
129120-77501	43	8
129129-14580	7	3
129129-77010	15	1
129129-77210	15	6
129129-77220	15	7
129129-77230	15	8
	34	8
	55	8
	15	9
	34	9
	55	9
129129-77250	15	10
129129-77260	15	21
	34	21
	55	21
	15	22
	34	22
	55	22
129129-77280	15	23
129129-77290	15	24
	34	24
	55	24
129129-77300	15	25
129129-77310	15	27
129129-77320	15	28
	34	28
	55	28
129129-77330	15	29
129129-77340	15	30
	34	30
	55	30
129129-77350	15	31
	34	31
	55	31
129129-77361	15	32
	34	34
	55	34
129129-77370	15	34
	34	32
	55	32
129129-77380	15	33
	34	33
	55	33
129129-77390	15	14
129129-77400	15	17
	34	16
	55	16
129129-77410	15	18
	34	17
	55	17

Parts No.	Fig. No.	Ref. No.
129129-77420	15	19
	34	19
	55	19
129129-77430	15	20
	34	20
	55	20
	34	14
129129-77440	55	14
	34	15
129129-77450	55	15
	10	37
	29	37
129132-49050	50	37
	9	16
	28	38
129136-34800	48	29
	1	31
	20	30
129150-01200	39	31
	1	11
	20	8
129150-02020	39	12
	7	4
	26	4
129150-02450	45	4
	1	34
	20	32
129150-02870	39	34
	1	28
	20	25
129150-02930	39	27
	1	37
	20	35
129150-02940	39	37
	23	47
	42	53
129150-03020	23	48
	42	54
	23	49
129150-03070	42	55
	2	11
	21	11
129150-03080	40	11
	4	37
	23	38
129150-03100	42	44
	4	32
	23	33
129150-11230	42	39
	4	33
	4	33
129150-11280	4	32
	23	33
	42	39
129150-11290	4	33

Parts No.	Fig. No.	Ref. No.
129150-11370	4	25
	23	24
	42	30
129150-11750	4	39
	23	40
	42	46
129150-11810	4	15
	23	13
	42	16
129150-14101	7	7
	26	7
	45	7
129150-14200	7	1
	26	1
	45	1
129150-14400	7	2
	26	2
	45	2
129150-21200	8	5
	27	5
	47	5
129150-23600	8	37
	27	31
	47	31
129150-23610	8	51
	27	39
	47	33
129150-25101	7	11
	26	10
	45	10
129150-25900	7	16
	26	15
	45	15
129150-25920	7	14
	26	13
	45	13
129150-32020	9	14
	19	14
	28	14
129150-35041	38	14
	48	14
	59	13
129150-35101	9	18
	19	15
	28	16
129150-35101	38	15
	48	16
	59	14
129150-35101	9	21
	28	22

Parts No. Index

Parts No.	Fig. No.	Ref. No.
129150-35101	48	22
129150-35111	9	22
	19	16
	28	23
	38	16
	48	23
	59	15
129150-35151	9	23
	28	24
	48	24
129150-35350	9	25
	28	26
	48	26
129150-39450	9	29
129150-49811	10	30
	19	19
	29	30
	38	19
	50	30
	59	18
129150-59120	53	20
129150-59131	13	23
	32	23
	53	23
129150-59580	13	41
	32	45
	53	47
129150-77202	16	2
	35	2
	56	2
129150-77203	16	2 -1
	35	2 -1
	56	2 -1
129150-77210	16	7
	35	7
	56	7
129150-77230	16	15
	35	15
	56	15
129150-77280	16	15 -1
	35	15 -1
	56	15 -1
129150-77511	5	7
	19	23
	24	7
	38	9
	43	9
	59	9
129150-91400	2	25
	21	25

Parts No.	Fig. No.	Ref. No.
129150-91400	40	25
129155-11260	4	30
	23	31
	42	37
129155-11270	4	31
	23	32
	42	38
129155-42350	10	16
	29	16
	50	16
129155-49800	10	29
	29	29
	50	29
129155-51020	11	6
	30	5
	51	5
129155-51050	11	9
	30	8
	51	8
129155-51060	11	10
	30	9
	51	9
129155-51140	11	15
	30	14
	51	14
129155-51180	11	17
	30	16
	51	16
129155-51200	11	19
	30	18
	51	18
129155-51270	11	26
	30	25
	51	25
129155-51280	11	27
	30	26
	51	26
129155-51320	11	31
	30	30
	51	30
129155-51340	11	32
	30	31
	51	31
129155-51370	11	35
	30	34
	51	34
129155-51380	11	36
	30	35
	51	35
129155-51390	11	37

Parts No.	Fig. No.	Ref. No.
129155-51390	30	36
	51	36
129155-51400	11	38
129155-51410	11	39
	30	38
	51	38
129155-51420	11	40
	30	39
	51	39
129155-51450	11	41
	30	40
	51	40
129155-51500	11	46
129155-51521	11	47
	30	46
	51	46
129155-51550	11	48
	30	47
	51	47
129155-51570	11	51
	30	50
	51	50
129155-51580	11	52
	30	51
	51	51
129155-51600	11	53
	30	52
	51	52
129155-51700	11	72
129155-51710	11	73
129155-51750	11	74
129155-51760	11	75
129155-51790	11	76
	30	75
	51	75
129155-51930	11	78
	30	77
	51	77
129155-51940	11	79
	30	78
	51	78
129155-52050	11	93
	19	34
	30	91
	38	21
	51	91
	59	20
129156-51910	11	77
	30	76
	51	76

Parts No.	Fig. No.	Ref. No.
129202-22300	8	29
	27	23
	47	23
129255-59580	13	52
129350-49530	10	20
	29	20
	50	20
129400-01520	2	5
	21	5
	40	5
129400-01730	22	6
	41	10
129400-01770	22	8
	41	6
129400-11350	23	45
	42	51
129400-12100	43	1
129400-13201	25	7
	38	12
129400-59910	53	25
129400-59920	53	29
129400-59930	53	33
129400-59940	53	37
129400-92420	19	44
	38	40
	59	42
129403-12080	43	5
129403-13130	44	2
129403-18091	46	40
	59	31
129403-18720	46	2
129403-18800	46	21
129403-39450	49	4
129403-39600	49	11
129403-39610	49	12
129406-18010	46	1
129406-18770	46	3
129406-18780	46	12
129406-18790	46	16
129406-18820	46	24
129406-18830	46	27
129407-01340	20	31
	38	2
129407-11700	23	7
129407-12110	24	1
	38	10
129407-12120	24	2
129407-13100	25	1
129407-13110	25	2
	38	11

Parts No. Index

Parts No.	Fig. No.	Ref. No.
129407-21000	27	1
	47	1
129407-32000	28	1
	48	1
129407-77010	34	1
	55	1
129407-77210	34	6
	55	6
129407-77220	34	7
	55	7
129407-77250	34	10
	55	10
129407-77280	34	23
	55	23
129407-77300	34	25
	55	25
129407-77310	34	27
	55	27
129407-77330	34	29
	55	29
129407-77390	34	13
	55	13
129407-77410	34	18
	55	18
129408-01330	39	32
	59	2
129408-59810	32	25
129408-59820	32	29
129408-59830	32	33
129408-59840	32	37
129410-77330	16	17
	35	17
	56	17
129411-44510	29	48
	50	48
129411-44560	29	52
	50	52
129411-91310	18	7
	37	7
	58	7
129411-91360	18	7 A
	37	7 A
	58	7 A
129412-18290	46	43
129412-18380	46	44
129418-18320	44	6 -1
129432-44740	29	17
	50	17
129436-35090	28	17
	48	17

Parts No.	Fig. No.	Ref. No.
129470-11080	42	12
129470-11090	42	13
129470-51040	30	6
129477-18101	46	41
	59	32
129500-11240	23	30
	42	36
129503-53000	53	2
129506-51040	51	6
129506-51100	11	12
	30	11
	51	11
129550-11290	23	34
	42	40
129550-11310	23	52
	38	8
	42	58
	59	8
129550-12111	43	2
	59	10
129550-13110	44	1
	59	11
129550-21650	47	9
129550-39450	28	31
129555-51400	30	37
	51	37
129555-51500	30	45
	51	45
129555-51700	30	71
	51	71
129555-51710	30	72
	51	72
129555-51750	30	73
	51	73
129555-51760	30	74
	51	74
129555-59510	14	36
	33	20
129693-44310	44	5 -1
129795-01780	3	18
	22	18
	41	18
129795-01800	2	4
	21	4
	40	4
129795-01950	2	10
	21	10
	40	10
129795-02411	1	14
	20	28

Parts No.	Fig. No.	Ref. No.
129795-02411	39	30
129795-11120	4	20
	23	19
	42	25
129795-11180	4	21
	23	20
	42	26
129795-21661	8	10
	27	10
	47	10
129795-49551	10	21
	19	18
	29	21
	38	18
	50	21
	59	17
171001-93100	19	37
	38	33
	59	35
171051-01921	1	10
	20	7
	39	7
171081-55910	14	29
	33	35
	54	36
171301-21650	27	9
171301-49010	10	54
171301-49020	10	55
171340-21590	8	13
171340-21650	8	9
171340-44740	10	17
171350-03090	4	1
	23	1
	42	1
171353-44760	10	18
	29	18
	50	18
171420-01600	3	2
	22	2
	41	2
171420-21590	27	13
	47	13
171420-44500	10	43
171420-49010	29	54
	50	54
171420-49020	29	55
	50	55
172010-08160	17	1
	36	1
	57	1

Parts No.	Fig. No.	Ref. No.
174307-51170	11	16
	30	15
	51	15
174307-51560	11	50
	30	49
	51	49
194180-51640	17	2
	36	2
	57	2
194185-56900	18	8
	37	8
	58	8
194990-22050	6	3
	25	3
	46	42
		45
22117-040000	12	9
	31	9
	52	9
22190-080002	2	23
		24
	19	25
	21	23
		24
	28	36
	38	23
	40	23
		24
	49	7
	59	22
22190-160002	11	89
	30	79
	51	79
22190-220002	3	11
	22	11
	41	9
22217-050000	11	80
	30	80
	51	80
22217-060000	11	81
	30	81
	51	81
22217-120000	7	17
	26	16
	45	16
22252-000260	8	30
	27	24
	47	24
22351-040010	8	8
	12	10

Parts No. Index

Parts No.	Fig. No.	Ref. No.
22351-040010	17	5
	27	8
	31	10
	36	5
	47	8
	52	10
	57	5
22351-050010	11	82
	30	82
	51	82
22351-060012	4	52
	23	25
	42	31
22360-050000	12	11
	31	11
	52	11
22512-070140	7	8
	8	6
	26	8
	27	6
23000-016000	45	8
	47	6
	10	38
	29	38
	50	38
23000-022000	49	13
23000-054000	43	6
23000-060000	43	7
23010-038000	10	56
	29	56
	50	56
	29	56
	50	56
23061-070230	10	49
	29	47
	50	47
23414-080000	9	35
	19	32
	39	15
	49	16
	9	36
23414-100000	19	33
	28	37
	38	24
	49	8
	59	23
	13	50
23414-120000	19	35
	32	54
	38	26
	53	56
	59	24
	17	5
	27	8
	31	10

Parts No.	Fig. No.	Ref. No.
23414-170000	46	46
	59	25
	14	30
23418-060000	33	36
	54	37
	1	15
	20	11
23871-010000	39	8
	10	12
23871-030000	20	15
	29	12
	27	27
	39	16
	42	19
	43	3
23894-030002	50	12
	27	27
	46	47
	11	83
	30	83
24101-063034	51	83
	4	51
	19	10
24311-000120	23	57
	38	27
	42	63
	59	26
	2	13
24311-000160	9	26
	14	14
	19	24
	21	13
	28	27
24311-000320	33	14
	38	28
	40	13
	48	27
	54	14
	59	27
	2	14
	4	49
	19	7
	8	8
14	14	
24311-000320	21	14
	23	53
	38	29
	40	14
	42	59
	59	27

Parts No.	Fig. No.	Ref. No.
24311-000320	59	28
	14	7
24311-240100	31	31
	7	37
24314-000160	54	7
	38	38
	49	14
24321-000650	14	10
	19	22
	33	10
	38	32
	54	10
	59	34
24341-000160	11	84
	30	84
	51	84
	2	27
	19	26
24341-000240	21	27
	38	30
	40	27
	59	29
	23	54
	38	31
24341-000500	42	60
	59	30
	10	57
	29	57
	50	57
26014-080202	16	18
	35	18
	56	18
	14	16
26014-080252	33	16
	54	16
	11	85
26014-080702	30	85
	51	85
	11	86
26022-050102	30	86
	51	86
	2	28
	21	28
26022-060162	40	28
	49	15
	12	12
	31	12
26106-060162	52	12
	12	13
	2	28
	21	28
26106-060202	49	15
	12	12
	31	12
	52	12
26106-060222	12	13

Parts No.	Fig. No.	Ref. No.
26106-060222	31	13
	52	13
26106-060352	10	19
	29	19
	50	19
26106-060452	12	14
	31	14
	52	14
26106-060602	12	15
	31	15
	52	15
	52	15
26106-060702	12	16
	31	16
	52	16
26106-060852	12	17
	31	17
	52	17
	49	9
26106-080102	2	15
	21	15
	39	17
	40	15
	4	7
26106-080122	23	6
	42	6
	46	48
	2	16
26106-080142	17	17
	3	12
	7	9
	20	29
	21	16
26106-080162	17	17
	22	12
	23	55
	39	33
	40	16
26106-080202	17	17
	41	12
	42	61
	2	18
	5	4
	9	27
26106-060162	10	33
	21	18
	24	4
	28	28
26106-060202	29	32
	40	18
	48	28
	48	28

Parts No. Index

Parts No.	Fig. No.	Ref. No.
26106-080202	50	32
26106-080252	3	13
	4	41
	10	32
	22	13
	23	43
	29	33
	41	13
	42	49
	50	33
26106-080302	3	19
	22	19
	41	19
26106-080352	3	20
	5	8
	9	20
	22	20
	24	8
	28	21
	41	20
	43	4
		10
	48	21
26106-080402	6	4
	25	4
26106-080452	2	19
	3	14
		14 -1
	7	15
	21	19
	22	14
		14 -1
	26	14
	40	19
	41	14
		14 -1
	45	14
26106-080502	3	21
	4	42
	5	5
	10	34
	22	21
	23	44
	24	5
	29	34
	41	21
	42	50
	50	34
26106-080552	2	20
	21	20

Parts No.	Fig. No.	Ref. No.
26106-080552	40	20
26106-080602	10	14
		35
	29	14
		35
	50	14
		35
26106-080652	44	3
26106-080852	2	21
	21	21
	40	21
	44	4
26106-081002	44	5
26106-100142	17	9
	36	9
	57	9
26116-050302	11	87
	30	87
	51	87
26116-060122	17	6
	36	6
	57	6
26116-060162	10	28
	29	28
	50	28
26116-120252	15	35
	34	35
	55	35
26206-100252	3	4
	22	4
	41	4
26206-100302	3	5
	22	5
	41	5
26216-060202	4	16
	23	15
	42	20
26216-080222	6	5
	25	5
	44	6
	46	49
26216-080402	6	6
	25	6
26226-080182	4	40
	23	41
	42	47
26366-060002	4	53
	23	26
	42	32
26366-080002	2	22

Parts No.	Fig. No.	Ref. No.
26366-080002	10	58
	21	22
	29	58
	40	22
	50	58
26366-100002	16	16
	35	16
	56	16
26450-060252	9	15
	28	15
	48	15
26557-040082	17	7
	36	7
	57	7
26716-060002	11	88
	30	88
	51	88
26716-120002	7	18
	26	17
	45	17
26756-080002	23	42
	42	48
27231-500000	1	16
	20	12
	39	9
27241-120000	1	17
	20	13
	39	10
27241-220000	42	21
27241-300000	1	18
	20	14
	39	11
27241-400000	4	17
	23	16
	42	22
27310-080001	4	22
	23	21
	42	27
28110-100120	19	40
	38	36
	59	38
28110-140170	19	41
	38	37
	59	39
28110-190220	19	42
	38	38
	59	40
28210-000140	19	43
	38	39
	59	41

Parts No.	Fig. No.	Ref. No.
719810-01500	2	1
	21	1
	40	1
719810-53100	13	1
	32	1
729001-01560	1	2
729002-01560	1	1
729212-51200	11	1
729212-51210	11	2
729212-92600	19	1
729212-92610	19	2
729402-14580	26	3
	45	3
729402-23100	8	31
	27	25
	47	25
729407-01561	20	1
729408-01560	39	1
729408-11700	42	7
729503-53100	53	1
729611-51200	51	1
729611-51210	30	1
729611-92600	38	1
729611-92610	59	1
977770-01212	19	45
	38	41
	59	43
X0280210230	15	11
	34	11
	55	11
X0283060061	15	2
	34	2
	55	2
X0283270140	15	12
	34	12
	55	12
X0289030010	15	3
	34	3
	55	3
X9490561370	15	4
	34	4
	55	4
X9491200240	15	5
	34	5
	55	5
X9491703371	15	13
X9491730461	15	26
	34	26
	55	26
XM069000000	16	8

Parts No. Index

Parts No.	Fig. No.	Ref. No.
XM069000000	35	8
	56	8
XM081780000	16	9
	35	9
	56	9
XM178780000	16	10
	35	10
	56	10
XM219230000	16	3
	35	3
	56	3
XM329830000	16	4
	35	4
	56	4
XM860250000	16	5
	35	5
	56	5
XM863720000	16	6
	35	6
	56	6
XYSPS400800	16	11
	35	11
	56	11
XYSPS402400	16	12
	35	12
	56	12

Parts No.	Fig. No.	Ref. No.
-----------	----------	----------

Parts No.	Fig. No.	Ref. No.
-----------	----------	----------

Parts No.	Fig. No.	Ref. No.
-----------	----------	----------